

March 2024

Types 1098-EGR and 1098H-EGR Pressure Reducing Regulators

WARNING

Failure to follow these instructions or to properly install and maintain this equipment could result in an explosion, fire and/or chemical contamination causing property damage and personal injury or death.

Fisher™ regulators must be installed, operated and maintained in accordance with federal, state and local codes, rules and regulations and Emerson Process Management Regulator Technologies, Inc. (Emerson) instructions.

If the regulator vents gas or a leak develops in the system, service to the unit may be required. Failure to correct trouble could result in a hazardous condition.

Installation, operation and maintenance procedures performed by unqualified personnel may result in improper adjustment and unsafe operation. Either condition may result in equipment damage or personal injury. Use qualified personnel when installing, operating and maintaining the Types 1098-EGR and 1098H-EGR pressure reducing regulator.

Introduction

Scope of the Manual

This manual describes and provides instructions and parts list for Type 1098-EGR or 1098H-EGR regulator complete with a standard P590 Series filter and either a 6350 Series regulator, a 61 Series



W6956

Figure 1. Type 1098-EGR

pilot or a Type Y600AM pilot. The Type 1806 check valve is also covered when a 61 Series pilot is used. Instructions and parts lists for monitoring pilots and other equipment used with this regulator are found in separate manuals.

Description

Types 1098-EGR and 1098H-EGR regulators provide economical and accurate pressure control in a wide variety of applications: natural gas distribution systems; fuel gas supply to industrial boilers, furnaces, ovens and mixers; and large commercial/industrial establishments such as shopping centers and schools. They are also used in plant air service and in liquid service.

Types 1098-EGR and 1098H-EGR

Specifications

The Specifications section lists pressure limitations and other specifications for various Types 1098-EGR and 1098H-EGR constructions. Specifications for a given regulator as it originally comes from the factory are stamped on nameplates located on both the actuator and main valve body, while the pilot control spring range is displayed on the pilot spring case and the pilot restriction code is stamped on the pilot body (S = **standard** gain, L = low gain and H = high gain). To determine maximum pressure ratings, the individual ratings for the main valve, actuator and pilot must all be considered.

<p>Body Sizes and End Connection Styles See Table 1</p> <p>Main Valve Maximum Inlet Pressure⁽¹⁾ 400 psig / 27.6 bar or body rating limit whichever is lower</p> <p>Maximum Pilot Supply Pressure⁽¹⁾⁽²⁾ 600 psig / 41.4 bar</p> <p>Outlet Pressure Ranges See Table 2</p> <p>Actuator Sizes and Maximum Pressures See Table 3</p> <p>Maximum and Minimum Differential Pressures See Table 4</p> <p>Main Valve Flow Characteristic Linear (standard), Whisper Trim™ or Quick opening</p>	<p>Main Valve Flow Direction In through the seat ring and out through the cage</p> <p>Pressure Registration External</p> <p>Process Temperature Capabilities⁽¹⁾⁽³⁾</p> <p>Nitrile (NBR): -20 to 180°F / -29 to 82°C</p> <p>Fluorocarbon (FKM): 0 to 300°F / -18 to 149°C, Water is limited to 0 to 200°F / -18 to 93°C</p> <p>Ethylenepropylene (EPDM): -20 to 275°F / -29 to 135°C</p> <p>Options</p> <ul style="list-style-type: none"> • NACE Construction • Boiler Fuel Construction • Aqueous Service Construction • Monitor Configuration • Noise Abatement Trim
--	---

1. The pressure/temperature limits in this Instruction Manual or any applicable standard limitation should not be exceeded.
 2. For stability or overpressure protection, a reducing regulator may be installed upstream of the pilot according to the Installation section.
 3. Special low temperature constructions for process temperatures between -76°F / -60°C to 185°F / 85°C are available by request. The low temperature construction passed Emerson laboratory testing for lockup and external leakage down to -76°F / -60°C.

Table 1. Body Sizes and End Connection Styles

BODY SIZE		CAST IRON	STEEL OR STAINLESS STEEL
NPS	DN		
1 or 2	25 or 50	NPT or CL125 FF	NPT, CL150 RF, CL300 RF, CL600 RF, BWE, SWE or PN 16/25/40
3, 4 or 6	80, 100 or 150	CL125 FF	CL150 RF, CL300 RF, CL600 RF, BWE or PN 16/25/40
8 x 6 or 12 x 6	200 x 150 or 300 x 150	---	CL150 RF, CL300 RF, CL600 RF or BWE

Types 1098-EGR and 1098H-EGR

Table 2. Outlet Pressure Ranges

PILOT TYPE	OUTLET PRESSURE RANGE		SPRING COLOR	SPRING PART NUMBER
	psig	bar		
6351	3 to 20 5 to 35 35 to 100	0.21 to 1.4 0.35 to 2.4 2.4 to 6.9	Green Unpainted Red	1B986027212 1B788327022 1K748527202
6352	14 in. w.c. to 2 psig 2 to 10	35 mbar to 0.1 bar 0.14 to 0.69	Yellow Black	14A9672X012 14A9673X012
6353	3 to 40 35 to 125	0.21 to 2.8 2.4 to 8.6	Yellow Red	1E392527022 1K748527202
6354L ⁽¹⁾	85 to 200	5.9 to 13.8	Blue	1L346127142
6354M ⁽²⁾	175 to 220	12.1 to 15.2	Blue	1L346127142
6354H ⁽²⁾	200 to 300	13.8 to 20.7	Green	15A9258X012
61L 61LD 61LE	7 in. w.c. to 2 psig 1 to 5 2 to 10 5 to 15 10 to 20	17 mbar to 0.1 bar 0.07 to 0.3 0.14 to 0.69 0.35 to 1.0 0.69 to 1.4	Red Yellow Blue Brown Green	1B886327022 1J857827022 1B886427022 1J857927142 1B886527022
61H	10 to 65	0.69 to 4.5	Green Stripe	0Y066427022
61HP	15 to 45 35 to 100 100 to 300	1.0 to 3.1 2.4 to 6.9 6.9 to 20.7	Yellow Blue Red	1E392527022 1D387227022 1D465127142
Y600AM	4 to 8 in. w.c. 7 to 16 in. w.c. 15 in. w.c. to 1.2 psig 1.2 to 2.5 2.5 to 4.5 4.5 to 7	10 to 20 mbar 17 to 40 mbar 37 mbar to 0.08 bar 0.08 to 0.17 0.17 to 0.31 0.31 to 0.48	Red Unpainted Yellow Green Light Blue Black	1B653827052 1B653927022 1B537027052 1B537127022 1B537227022 1B537327052

1. Without diaphragm limiter.
2. With diaphragm limiter.

Table 3. Actuator Sizes and Maximum Pressures

ACTUATOR TYPE	ACTUATOR SIZE	OUTLET CONTROL PRESSURE		EMERGENCY CASING PRESSURE	
		psig	bar	psig	bar
1098	30 40 (standard) 70	100 75 50	6.9 5.2 3.4	115 82 65	7.9 5.6 4.5
1098H	30	300	24.1	400	27.6

Table 4. Maximum and Minimum Differential Pressures for Main Valve Selection

BODY SIZE		SPRING PART NUMBER	SPRING COLOR	MAXIMUM ALLOWABLE DIFFERENTIAL PRESSURE ⁽¹⁾		MINIMUM DIFFERENTIAL PRESSURE REQUIRED FOR FULL STROKE					
						Size 30 Actuator		Size 40 Actuator		Size 70 Actuator	
NPS	DN			psig	bar	psig	bar	psig	bar	psig	bar
1	25	14A9687X012	Green	60	4.1	3.5	0.24	2.5	0.17	1	0.07
		14A9680X012	Blue	125	8.6	5	0.34	3	0.21	1.5	0.10
		14A9679X012	Red	400 ⁽³⁾	27.6 ⁽³⁾	7	0.48	5	0.34	2.5	0.17
2	50	14A6768X012	Yellow	20	1.4	----	----	2	0.14	1	0.07
		14A6626X012	Green	60	4.1	4	0.28	3	0.21	1.5	0.10
		14A6627X012	Blue	125	8.6	6	0.41	5	0.34	2	0.14
		14A6628X012	Red	400 ⁽³⁾	27.6 ⁽³⁾	11	0.76	10	0.69	3	0.21
3	80	14A6771X012	Yellow	20	1.4	----	----	2.5	0.17	1	0.07
		14A6629X012	Green	60	4.1	5	0.34	4	0.28	2	0.14
		14A6630X012	Blue	125	8.6	8	0.55	6	0.41	2.5	0.17
		14A6631X012	Red	400 ⁽³⁾	27.6 ⁽³⁾	14	0.97	11	0.76	4	0.28
4	100	14A6770X012	Yellow	20	1.4	----	----	3.5	0.25	1.3	0.09
		14A6632X012	Green	60	4.1	10	0.69	5	0.34	2.5	0.17
		14A6633X012	Blue	125	8.6	13	0.90	8	0.55	3	0.21
		14A6634X012	Red	400 ⁽³⁾	27.6 ⁽³⁾	22	1.5	13	0.90	5	0.34
6, 8 x 6 or 12 x 6	150, 200 x 150 or 300 x 150	15A2253X012	Yellow	20	1.4	----	----	6	0.42	2.2	0.15
		14A9686X012	Green	60	4.1	13	0.90	9.5	0.66	4	0.28
		14A9685X012	Blue	125	8.6	19	1.3	14	0.97	6	0.41
		15A2615X012	Red	400 ⁽³⁾	27.6 ⁽³⁾	28 ⁽²⁾	1.9 ⁽²⁾	19	1.3	8	0.55

1. Maximum inlet pressure is equal to set pressure plus maximum differential.
2. Requires special 6300 Series pilot construction without integral check valve and with external Type 1806H 40 psid / 2.8 bar d check valve.
3. Should not exceed the body rating limit. Use this pressure value or the body rating limit, whichever is lower.

Types 1098-EGR and 1098H-EGR

Table 5. Recommended Type MR95H Pressure Settings for Use with the Type Y600AM Pilot

BODY SIZE		TYPE EGR SPRING COLOR	SUPPLY PRESSURE											
			Type Y600AM Spring Color											
NPS	DN		Red		Unpainted		Yellow		Green		Light Blue		Black	
		psig	bar	psig	bar	psig	bar	psig	bar	psig	bar	psig	bar	
1	25	Green	6	0.41	6	0.41	7	0.48	8	0.55	11	0.76	13	0.90
		Blue	7	0.48	7	0.48	8	0.55	10	0.69	13	0.90	14	0.97
		Red	8	0.55	8	0.55	9	0.62	11	0.76	14	0.97	15	1.0
2	50	Green	6	0.41	6	0.41	7	0.48	9	0.62	12	0.83	13	0.90
		Blue	8	0.55	8	0.55	9	0.62	11	0.76	14	0.97	15	1.0
		Red	13	0.90	13	0.90	14	0.97	16	1.1	19	1.3	20	1.4
3	80	Green	7	0.48	7	0.48	8	0.55	10	0.69	13	0.90	14	0.97
		Blue	9	0.62	9	0.62	10	0.69	12	0.83	15	1.0	16	1.1
		Red	14	0.97	14	0.97	15	1.0	17	1.2	20	1.4	21	1.5
4	100	Green	8	0.55	8	0.55	9	0.62	11	0.76	14	0.97	15	1.0
		Blue	11	0.76	11	0.76	12	0.83	14	0.97	17	1.2	18	1.2
		Red	16	1.1	16	1.1	17	1.2	19	1.3	22	1.5	23	1.6
6 or 8 x 6	150 or 200 x 150	Green	13	0.90	13	0.90	14	0.97	15	1.0	18	1.2	20	1.4
		Blue	17	1.2	17	1.2	18	1.2	20	1.4	23	1.6	24	1.7
		Red	22	1.5	22	1.5	23	1.6	25	1.7	28	1.9	29	2.0

1. The pressures shown in the table are the minimum supply pressures required by the pilot. If the inlet pressure is less than shown, an external pilot supply is necessary.

Principle of Operation

The pilot-operated Types 1098-EGR and 1098H-EGR regulators both use inlet pressure as the operating medium, which is reduced through pilot operation to load the actuator diaphragm. Outlet or downstream pressure opposes loading pressure in the actuator and also opposes the pilot control spring. The Type 1098-EGR regulator operation schematic is shown in Figure 2.

In operation, assume that outlet pressure is below the pilot control setting. Control spring force on the pilot diaphragm opens the pilot valve plug providing additional loading pressure to the actuator diaphragm. This loading pressure forces the actuator stem forward, opening the main valve plug via a bump connection. The upward motion of the plug allows gas to flow through the cage into the downstream system.

When downstream demand has been satisfied, outlet pressure tends to increase, acting on the pilot and actuator diaphragms. This pressure exceeds the pilot control spring setting, moving the pilot diaphragm away and letting the valve plug spring (Type 6351, 61 Series or Type Y600AM pilots) or bellows

(Types 6352 through 6354M pilots) close the pilot valve plug (unbalanced in the Type 6351 or 61 Series pilots but balanced in the Types 6352 through 6354M pilots). Excess loading pressure on the actuator diaphragm escapes downstream through the bleed hole (Type 6351 pilot), bleed orifice (61 Series pilot), restriction (Types 6352 through 6354M pilots) or fixed restrictor (Type Y600AM pilot).

Reduced actuator loading pressure permits the main valve to close. The combination of main valve spring force and valve plug imbalance provides positive valve plug shutoff against the port and upper seals.

To protect the Type 1098 or 1098H actuator diaphragm from excessive differential pressure, the 6350 Series pilots have an integral check valve that allows loading pressure to bleed downstream at approximately 25 psig / 1.7 bar differential across the actuator diaphragm. An external check valve (Type 1806) is required when the required minimum differential is higher than 25 psi / 1.7 bar or when using the 61 Series or Y600AM pilots with the normal operation of the regulator.

Types 1098-EGR and 1098H-EGR

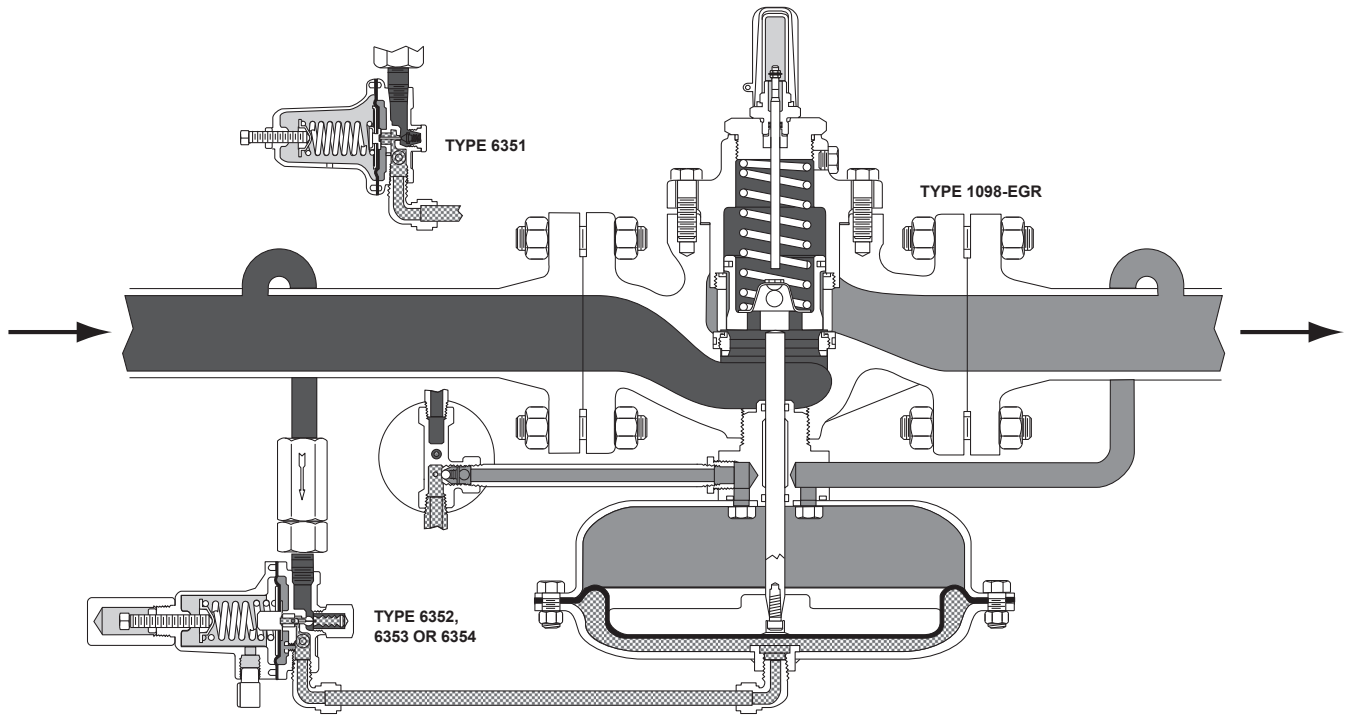

A6563

TYPE 1098-EGR WITH 6350 SERIES PILOT

- INLET PRESSURE
- OUTLET PRESSURE
- ATMOSPHERIC PRESSURE
- LOADING PRESSURE

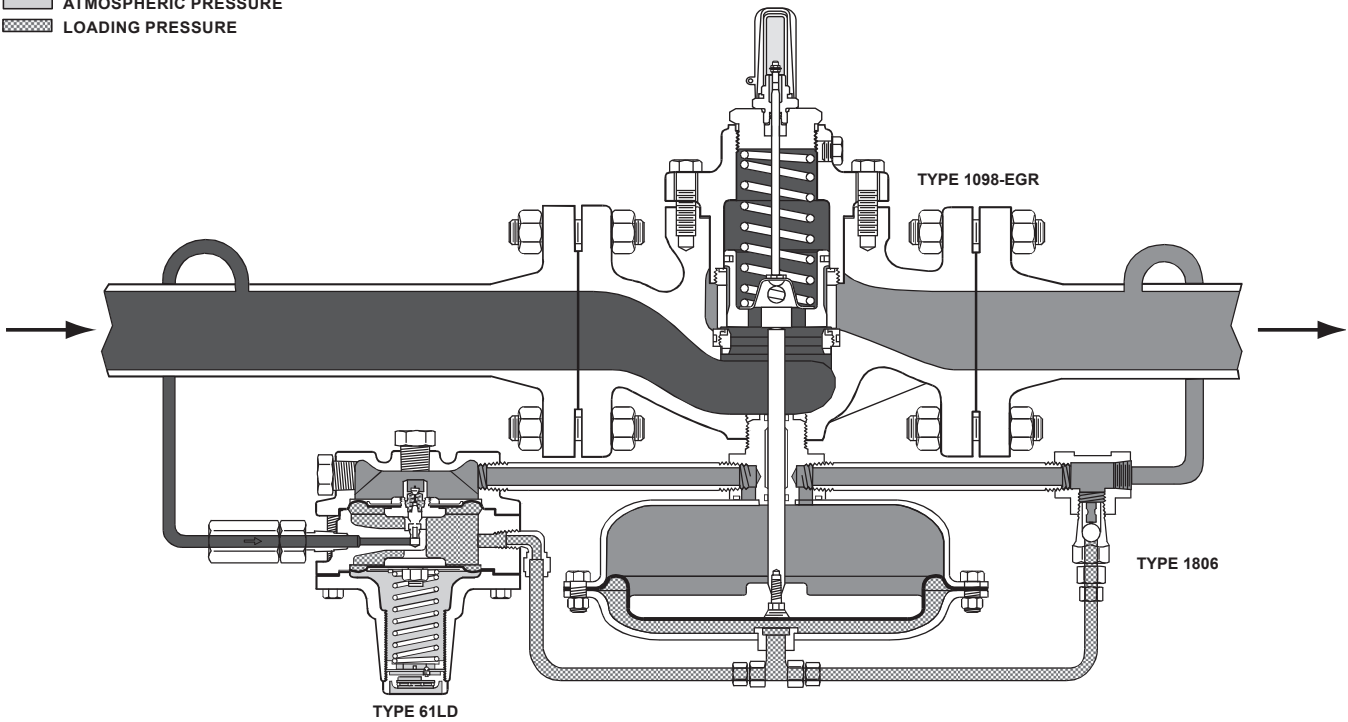

A6641

TYPE 1098-EGR WITH TYPE 61LD PILOT

- INLET PRESSURE
- OUTLET PRESSURE
- ATMOSPHERIC PRESSURE
- LOADING PRESSURE

Figure 2. Operational Schematics

Types 1098-EGR and 1098H-EGR

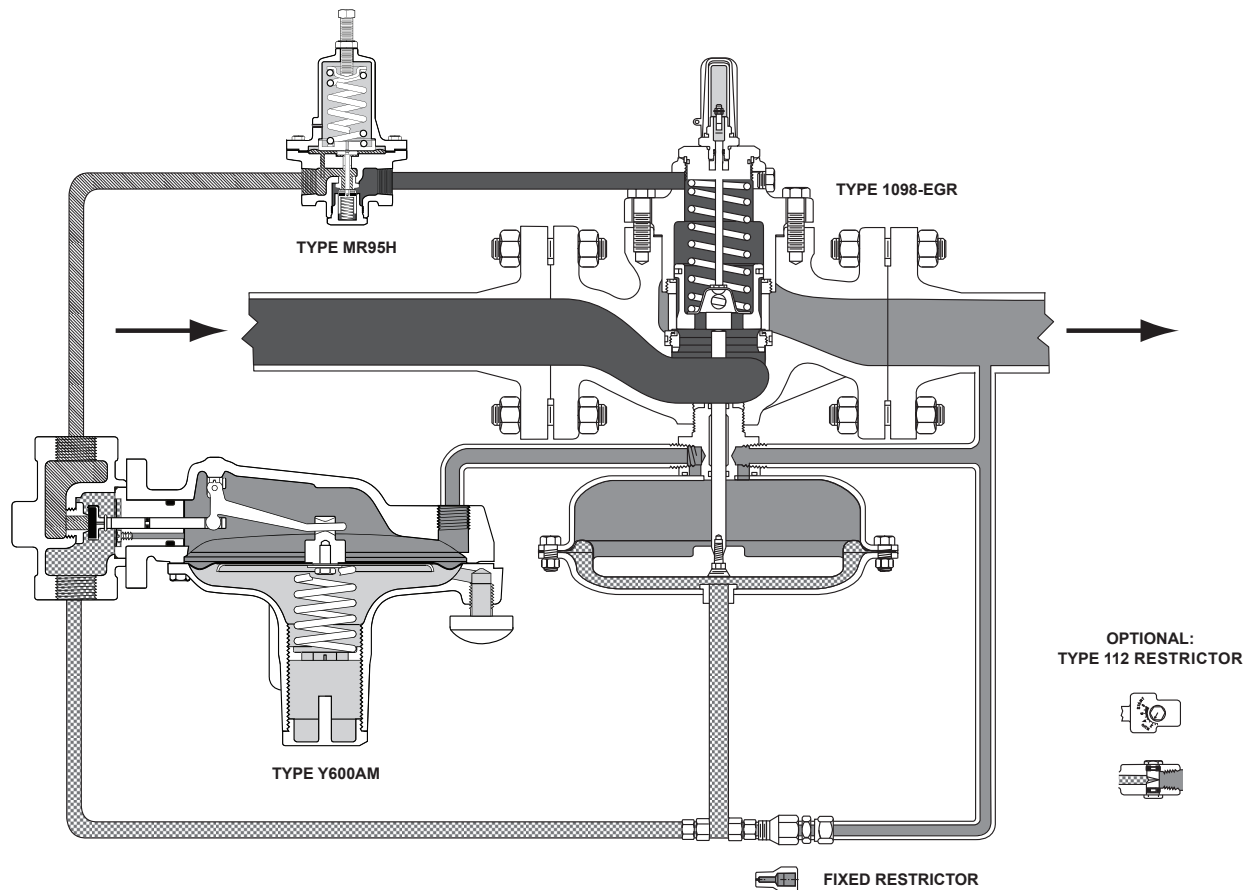

TYPE 1098-EGR WITH TYPE Y600AM PILOT AND TYPE MR95H PRESSURE SUPPLY REGULATOR

M1008

- INLET PRESSURE
- OUTLET PRESSURE
- ATMOSPHERIC PRESSURE
- LOADING PRESSURE
- PILOT SUPPLY PRESSURE

Figure 2. Operational Schematics (continued)

Installation and Startup

WARNING

Personal injury, equipment damage or leakage due to escaping accumulated gas or bursting of pressure-containing parts may result if this regulator is overpressured or is installed where service conditions could exceed the limits given in the Specifications section and on the appropriate nameplate or where conditions exceed any ratings of the adjacent piping or piping connections. To avoid such injury or damage, provide pressure-relieving or pressure-limiting devices to

prevent service conditions from exceeding those limits.

Additionally, physical damage to the regulator may result in personal injury and property damage due to escaping accumulated gas. To avoid such injury and damage, install the regulator in a safe location.

Standard Single-Pilot Regulator (Figure 3)

Installations

A Type 1098-EGR or Type 1098H-EGR regulator bleeds no gas to the atmosphere, making it suitable for installation in pits or other enclosed locations without elaborate venting systems. This regulator can also be

Types 1098-EGR and 1098H-EGR

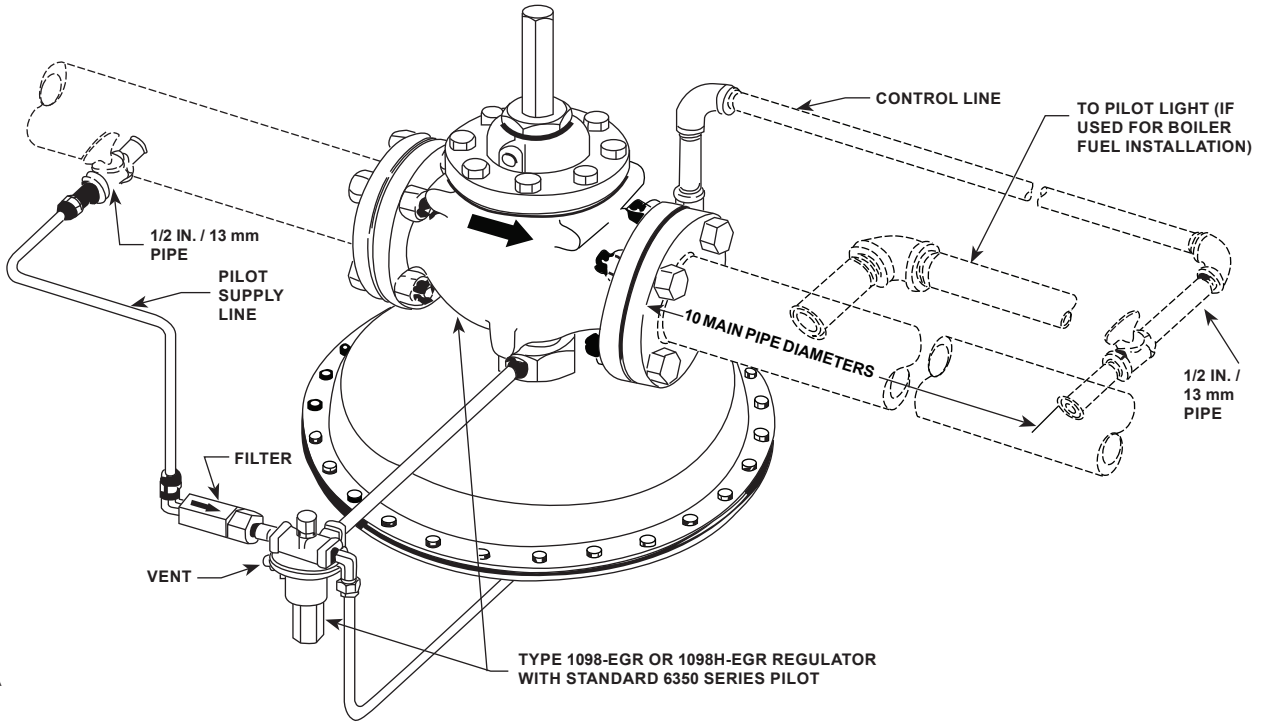

Figure 3. Standard Single-Pilot Installation

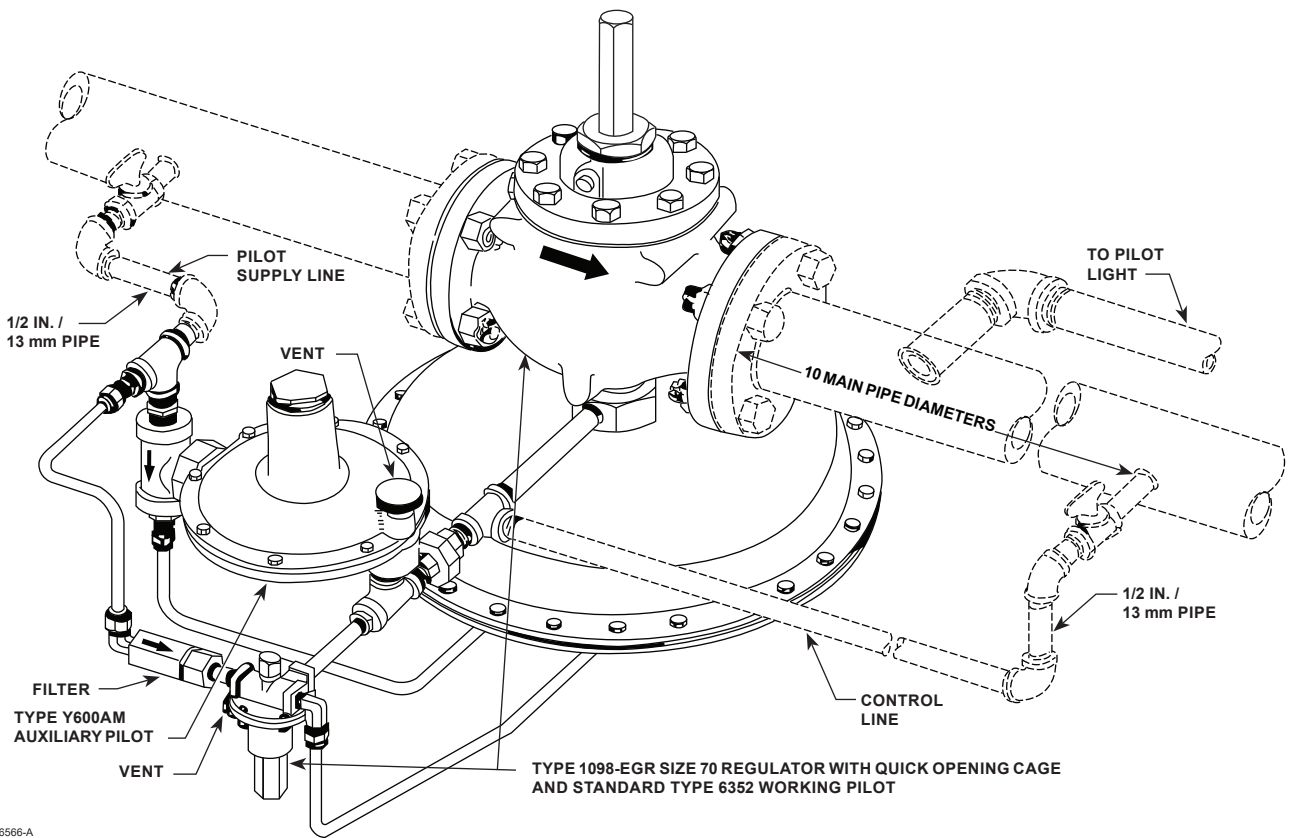

Figure 4. Typical Dual-Pilot Boiler Fuel Installation

Types 1098-EGR and 1098H-EGR

installed in pits subject to flooding by venting the pilot spring case above the expected flood level so that the pilot diaphragm is exposed to atmospheric pressure.

Note

Normal pressure drop assists shutoff. Therefore, leakage may result during any reverse pressure drop condition.

1. Use qualified personnel when installing, operating and maintaining regulators. Before installing, inspect the main valve, pilot and tubing for any shipment damage or foreign material that may have collected during crating and shipment. Make certain the body interior is clean and the pipelines are free of foreign material. Apply pipe compound only to the external pipe threads with a screwed body or use suitable line gaskets and good bolting practices with a flanged body.

With a weld end body, be sure to remove the trim package, including the gasket, according to the Maintenance section before welding the body into the line. Do not install the trim package until any post-weld heat treatment is completed. If heat treating, prevent scale buildup on all machined guiding and sealing surfaces inside the body and at the bonnet flange/body joint.

2. The regulator maybe installed in any orientation, as long as flow through the regulator matches the direction of the flow arrow attached to the valve body. However, mounting the main valve with the valve stem in a horizontal position may experience stem wear on units with a size 70 actuator or NPS 4 and larger.
3. Install a three-valve bypass around the regulator if continuous operation is necessary during maintenance or inspection. The pilot may be field-changed to the opposite-side mounting position by swapping the pilot pipe nipple to the opposite bonnet tapping.



WARNING

A regulator may vent some gas to the atmosphere. In hazardous or flammable gas service, vented gas may accumulate and cause personal injury, death or property damage due to fire or explosion. Vent a regulator in hazardous gas service to a remote, safe location away from air intakes or any hazardous location. The vent line or stack opening

must be protected against condensation or clogging.

4. To keep the pilot spring case vent from being plugged or the spring case from collecting moisture, corrosive chemicals or other foreign material, point the vent down or otherwise protect it. To remotely vent the standard pilot, remove the vent and install obstruction-free tubing or piping into the 1/4 NPT vent tapping. Provide protection on a remote vent by installing a screened vent cap into the remote end of the vent pipe.
5. Run a 3/8 in. / 9.5 mm outer diameter or larger pilot supply line from the upstream pipeline to the filter inlet as shown in Figure 3. Do not make the upstream pipeline connection in a turbulent area, such as near a nipple, swage or elbow. If the maximum pilot inlet pressure could exceed the pilot rating, install a separate reducing regulator in the pilot supply line. Install a hand valve in the pilot supply line and provide vent valves to properly isolate and relieve the pressure from the regulator.
6. Attach a 1/2 NPT downstream pressure control line downstream of the regulator in a straight run of pipe, as shown in Figure 3. Do not make the tap near any elbow, swage or nipple that might cause turbulence. Connect the other end of the control line to the bonnet connection. Install a hand valve in the control line to shut off the control pressure when the bypass is in use.
7. If a quick acting solenoid is to be installed downstream of the regulator, the regulator and solenoid should be located as far apart as practical. This maximizes the gas piping volume between the regulator and solenoid and improves the regulator response to quick-changing flow rates.
8. For optional remote pneumatic loading of a 6350 or 61 Series pilot, make the loading piping connections to the 1/4 NPT vent connection.

Pre-startup Considerations

Before beginning the startup procedures in this section, make sure the following conditions are in effect:

- Block valves isolate the regulator.
- Vent valves are closed.
- Hand valves are closed.



CAUTION

Introduce pilot supply pressure into the regulator before introducing any downstream pressure or internal damage may occur due to reverse pressurization of the pilot and main valve components.

Always use pressure gauges to monitor downstream pressure during startup. Procedures used in putting this regulator into operation must be planned accordingly if the downstream system is pressurized by another regulator or by a manual bypass.

Note

For proper operation, pilot supply pressure must exceed control pressure by the minimum amount specified on the actuator nameplate as minimum differential pressure.

The only adjustment necessary on a Type 1098-EGR or 1098H-EGR regulator is the pressure setting of the pilot control spring. Turning the adjusting screw clockwise into the spring case increases the spring compression and pressure setting. Turning the adjusting screw counterclockwise decreases the spring compression and pressure setting.

Pilot Adjustment

To adjust standard 6350 Series pilots: Loosen the locknut and turn the adjusting screw. Then tighten the locknut to maintain the adjustment position. On a standard Types 6352 through 6354M pilots, closing cap must be removed before adjustment and replaced afterward.



WARNING

To avoid possible personal injury from a pressure-loaded pilot, carefully vent the spring case before removing the closing cap. Otherwise, trapped loading pressure could forcefully eject the freed closing cap.

To adjust the 61 Series or Type Y600AM pilots: Remove the closing cap and turn the adjusting screw. Any adjustments made should set the controlled pressure within the appropriate spring range shown in the Table 2.

Startup

1. Slowly open the pilot supply line hand valve.
2. Slowly open the upstream block valve and partially open the downstream block valve for minimum flow. Slowly open the hand valve in the control line.
3. Adjust the pilot setting, if necessary.
4. Completely open the downstream block valve.
5. Slowly close the bypass valve, if any.

Dual-Pilot Boiler Fuel Control

Applications

To enhance proper operation and adequate response to negative pressure shock condition in low differential pressure boiler fuel control applications, use the Type 1098-EGR boiler fuel configuration:

- Type 1098-EGR with Type 6352 pilot
- Size 70 Actuator
- Quick Opening Cage
- Yellow Main Spring
- Type Y600AM or 627M Auxiliary Pilot mounted in parallel with the Type 6352 pilot

To provide faster response, two pilots mounted in parallel sense the downstream pressure. The Type 6352 pilot is the primary controlling pilot and the Type Y600AM or 627M auxiliary pilot stands by until it senses a negative pressure shock condition. The auxiliary pilot opens, allowing additional flow into the actuator, increasing the stroking speed and providing faster response. See Figure 4 for schematic. The quick-opening cage allows maximum capacity at shorter travels to decrease stroking time in opening and closing directions. The service conditions should not exceed 20 psig / 1.4 bar maximum inlet pressure and 10 psi / 0.69 bar maximum differential pressure.

If a pilot light is present, supply it gas with the Type 1098-EGR. The pilot light gas supply line should branch off the main fuel line downstream of the Type 1098-EGR and include a separate regulator to control the final pilot light gas pressure, if required (see Figure 5). This allows the Type 1098-EGR to have its main valve plug just off the seat waiting for the sudden negative shock created when the boiler solenoid valve is opened to light the boiler to the high fire load. This installation practice significantly increases the stroking speed of the Type 1098-EGR. See Figure 5 for schematic.

Types 1098-EGR and 1098H-EGR

Note

Modulating solenoid load valves provide a definite time delay in moving from one position to the other, effectively preventing sudden pressure changes in the system. Alternately, a snap-acting solenoid valve can be furnished with a characterized valve plug that, by allowing maximum capacity to be reached at a greater proportion of total travel, slows the action slightly. This action does not control shock as effectively as modulating solenoid valves.

Installation

1. Perform the Standard Single-Pilot Regulator Installation section through step 4, making sure that the regulator is installed with the actuator below the main valve as shown in Figure 4.
2. Run a 1/2 in. / 13 mm or larger pilot supply line from the upstream pipeline to the 1/2 NPT supply connection in the pipe tee as shown in Figure 4. Do not make the connection in a turbulent area, such as near a nipple, swage or elbow. If the maximum pilot inlet pressure could exceed the pilot rating, install a separate regulator in the pilot supply line and provide vent valves so that pressure can be properly isolated and relieved from the regulator.
3. Attach a 1/2 NPT downstream pressure control line ten pipe diameters downstream of the regulator in a straight run of pipe. Do not make the tap near any elbow, swage or nipple, which might cause turbulence. Connect the other end of the control line to the 1/4 NPT connection in the control pipe tee as shown in Figure 4. Install a hand valve in the control line to shut off the control pressure when the bypass is in use. Also use the hand valve to dampen out pulsations, which may cause instability or cycling of the regulator.
4. Consult the appropriate instruction manual for installation of an optional pneumatic or electric remote control drive unit. For optional remote pneumatic loading of 6350 or 61 Series pilots, make the loading piping connections to the 1/4 NPT vent connection.

Startup

1. Slowly open the pilot supply line hand valve.
2. Slowly open the upstream block valve and partially open the downstream block valve for minimum flow.

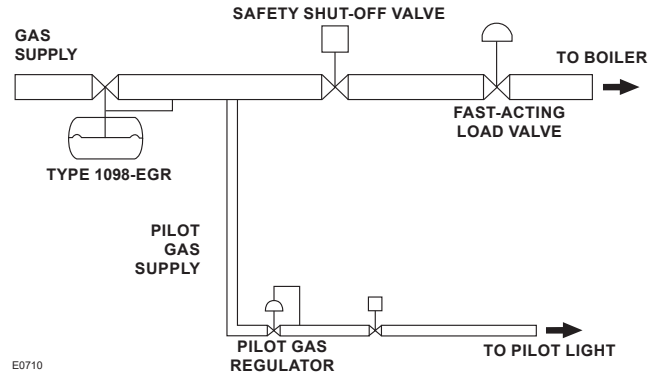

Figure 5. Boiler Fuel Configuration Installation Guide

3. Slowly open the hand valve in the control line and make sure that the standby pilot is set far enough below the working pilot so that the standby pilot remains closed during normal operation. For example, with final desired settings of 11 in. w.c. / 27 mbar for the working pilot and 10 in. w.c. / 25 mbar for the standby pilot, begin by reducing the working pilot setting far enough below 10 in. w.c. / 25 mbar for the working pilot to shut off. Then set the standby pilot for an outlet pressure of 10 in. w.c. / 25 mbar. Finally, set the working pilot for an outlet pressure of 11 in. w.c. / 27 mbar. Table 6 shows how close the standby pilot can be set to the working pilot setting.
4. Completely open the downstream block valve.
5. Slowly close the bypass valve, if any.

Working Monitor (Figure 6)

Installation

1. For both working monitor regulator and working regulator, perform the Standard Single-Pilot Regulator Installation section through step 7.
2. Connect another downstream pressure control line and hand valve (Figure 6) to the monitoring pilot according to the monitoring pilot instruction manual. Attach a 1/2 NPT pressure control line and hand valve from the intermediate pressure pipeline to the working monitor regulator. Pipe supply pressure between the monitoring pilot and the working monitor regulator according to the monitoring pilot manual.

For two typical monitoring pilots, Table 7 gives the spread between normal distribution pressure and the minimum pressure at which the working monitor regulator can be set to take over if the working regulator fails to open.

Types 1098-EGR and 1098H-EGR

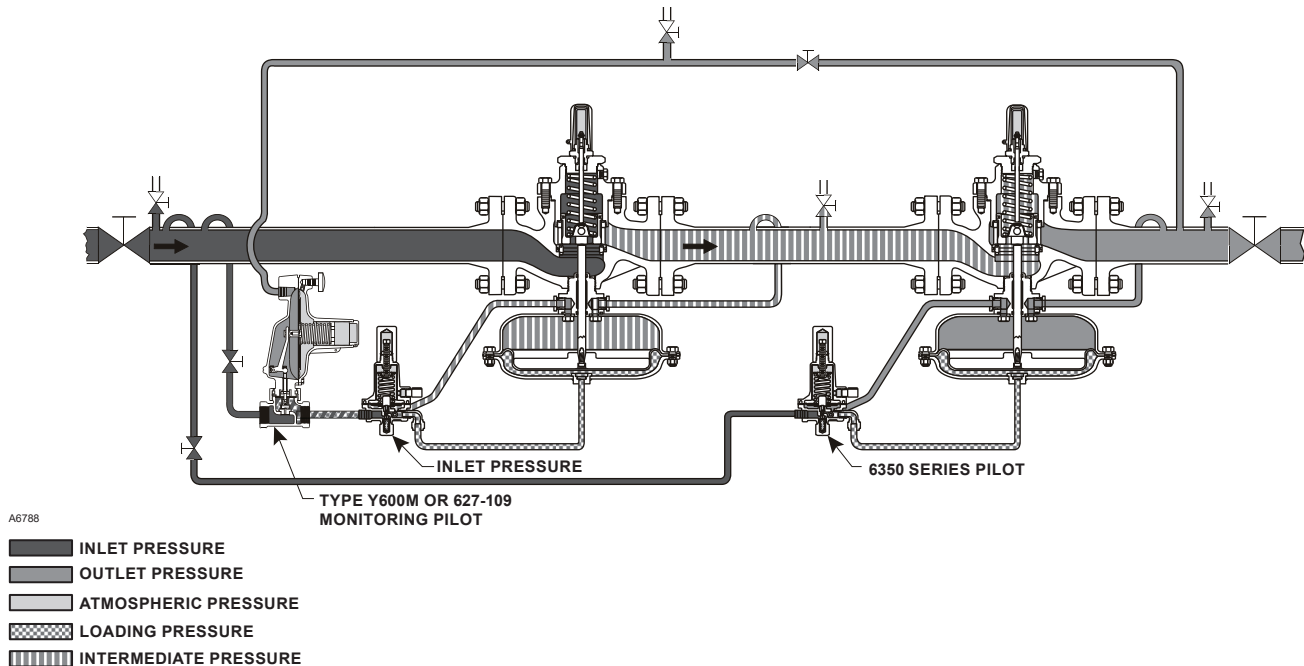

Figure 6. Typical Working Monitor Installation

Startup

On a working monitor installation (Figure 6), be sure that the second-stage working regulator is set to operate at a pressure lower than the Type 1098-EGR or 1098H-EGR working monitor regulator. To do this, increase the setting of the monitoring pilot until the working pilot is in control of the intermediate pressure and the second-stage working regulator is in control of the downstream pressure. If this is not done, the monitoring pilot tries to take control of the downstream pressure.

1. Slowly open the upstream block valve and the hand valves in both pilot supply lines. This energizes both pilots so that their setpoints can be adjusted. Partially open the downstream block valve for minimum flow.
2. To enable intermediate pressure adjustment with the working monitor regulator, slowly open the hand valve in the intermediate pressure control line.
3. To enable downstream pressure adjustment with the second-stage working regulator, slowly open the hand valve in the control line to this regulator.
4. Adjust the setting of the monitoring pilot to establish the desired emergency downstream pressure, which is to be maintained in the event of open failure of the second-stage working regulator. The emergency downstream pressure should exceed the desired downstream pressure by at least the amount listed in Table 7. The steps followed to set the monitoring pilot may vary with each piping situation; however, the basic method remains the same. The following sub steps a and b may be used as examples for setting the monitoring pilot:
 - a. Increase the outlet pressure setting of the second-stage working regulator until the monitoring pilot takes control of the downstream pressure. Adjust the monitoring pilot setting until the desired emergency downstream pressure is achieved. Then, readjust the second-stage working regulator to establish the desired downstream pressure.
 - b. Install special piping (not shown in Figure 6) so that the monitoring pilot senses the intermediate pressure. The intermediate pressure then appears to the monitoring pilot as if it was increased downstream pressure and the monitoring pilot controls and reduces the intermediate pressure. Adjust the monitoring pilot setting until the desired emergency downstream pressure is achieved at the intermediate pressure stage. Then slowly close the special piping and open up the monitoring downstream control line for normal service.
5. Slowly open the downstream block valve.
6. Slowly close the bypass valve, if any.

Types 1098-EGR and 1098H-EGR

Table 6. Auxiliary Pilot Selection (Fast Stroke Dual Pilot)

SIZE	CONSTRUCTION	ORIFICE		SPRING RANGE		SPRING NUMBER	SPRING COLOR	MINIMUM PRESSURE AT WHICH AUXILIARY PILOT CAN BE SET
		In.	mm	psi	bar			
3/4 NPT	Type Y600AM	1/4	6.4	4 to 8 in. w.c.	10 to 20 mbar	1B653827052	Red	1 in. w.c. / 2 mbar Under working pilot setpoint
				7 to 16 in. w.c.	17 to 40 mbar	1B653927022	Unpainted	
				15 in. w.c. to 1.2 psi	37 mbar to 0.08 bar	1B537027052	Yellow	
				1.2 to 2.5	0.08 to 0.17	1B537127022	Green	6 in. w.c. / 14 mbar Under working pilot setpoint
				2.5 to 4.5	0.17 to 0.31	1B537227022	Light Blue	
				4.5 to 7	0.31 to 0.48	1B537327052	Black	
	Type 627M	1/2	13	5 to 10	0.34 to 0.69	10B3076X012	Yellow	8 in. w.c. / 21 mbar Under working pilot setpoint

Table 7. Working Monitor Performance

MONITORING PILOT INFORMATION				MINIMUM PRESSURE AT WHICH WORKING MONITOR REGULATOR CAN BE SET
Construction	Spring Range		Spring Part Number	
	psig	bar		
Type 161AYW pilot and 150 psig / 10.3 bar maximum allowable pilot inlet pressure	3 to 12 in. w.c. 11 to 25 in. w.c.	7 to 30 mbar 27 to 62 mbar	1B653927022 1B537027052	3 in. w.c. / 7 mbar over normal distribution pressure
	25 in. w.c. to 2.5 psi 2.5 to 4.5 psi 4.5 to 7 psi	62 mbar to 0.17 bar 0.17 to 0.31 0.31 to 0.4	1B537127022 1B537227022 1B537327052	14 in. w.c. / 34 mbar over normal distribution pressure
Type 627-109 pilot and 1000 psi / 69 bar maximum allowable pilot inlet pressure	5 to 20 15 to 40 35 to 80	0.34 to 1.4 1.0 to 2.8 2.4 to 5.5	10B3076X012 10B3077X012 10B3078X012	3.0 psig / 0.21 bar over normal distribution pressure
	70 to 150 130 to 200	4.8 to 10.3 9.0 to 13.8	10B3079X012	5.0 psig / 0.34 bar over normal distribution pressure

Wide-Open Monitor (Figure 7)

Either the upstream or downstream regulator can be the monitor regulator. During normal operation, the monitoring regulator is standing wide open with the reduction to distribution pressure being taken across the working regulator. Only in case of open failure of the working regulator does the wide open monitoring regulator take control at its slightly higher setting.

Note that if using a downstream monitor setup, the upstream working regulator actuator must be rated to the application's full inlet pressure or be protected from it in case it fails wide-open.

Regardless of which regulator is used as the monitor, it should be equipped with a pilot supply regulator set to 5 psig / 0.34 bar plus the monitor minimum differential pressure above the monitor regulator pressure setting. Since the pilot on the monitoring regulator is wide open during normal operation, the pilot supply regulator prevents differential check valve chatter on the monitoring regulator pilot.

Adjustment Recommendations for Monitor Applications

Low amplitude/high frequency monitor trim oscillations can occur if the monitor regulator pressure setting is adjusted too closely to the working regulator pressure setting and/or if the monitor pilot supply regulator pressure setting is adjusted too closely to the monitor regulator pressure setting. The monitor pressure setting should be adjusted so it is at minimum two times the pilot proportional band pressure above the working regulator pressure setting. These adjustments must be made such that other governing pressure limits, such as casing ratings, pilot maximum differential pressures or regulatory limits, are not exceeded.

Installation

1. For both the wide-open monitoring regulator and the working regulator, perform the Standard Single-Pilot Regulator Installation section through step 7.

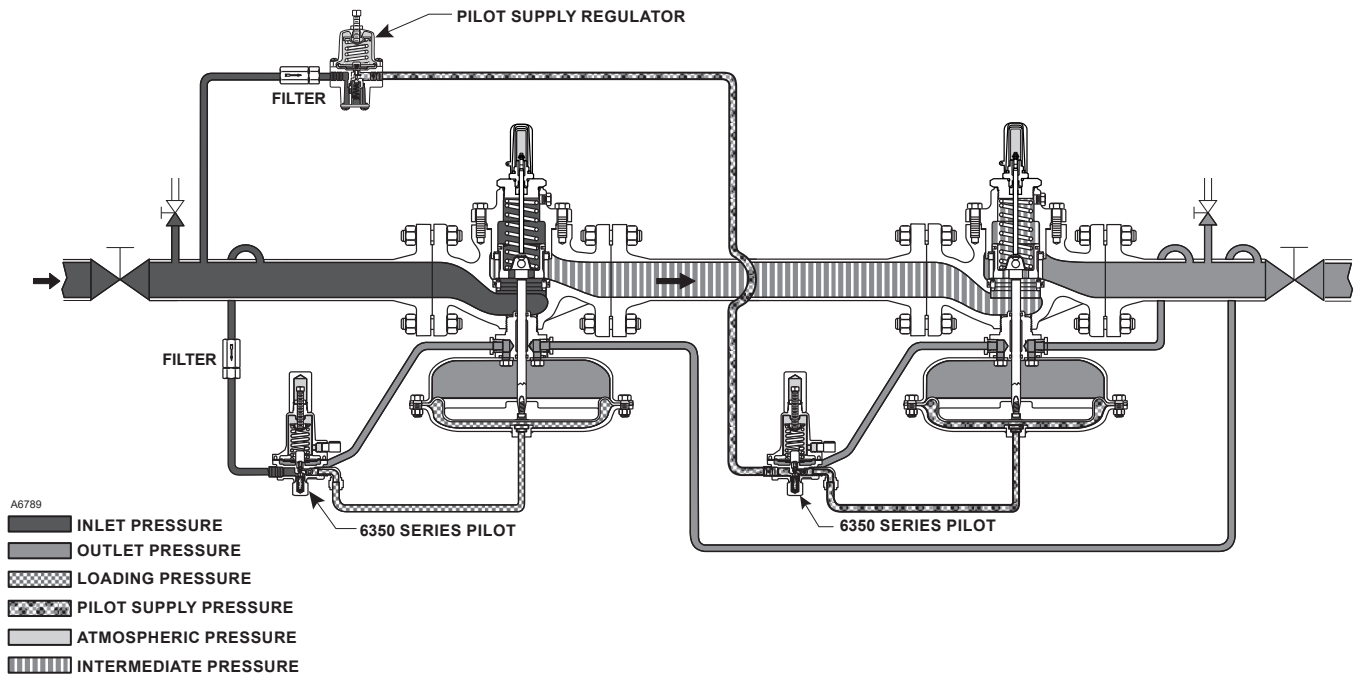

Figure 7. Typical Wide-Open Monitor Installations

2. Connect the control line of the wide-open monitoring regulator (Figure 7) to downstream piping near the working regulator control line connection. During normal operation the wide-open monitoring regulator stands wide-open with the pressure reduction being taken across the working regulator. Only in case of working regulator failure does the wide-open monitoring regulator take control at its slightly higher setting.

Startup

Repeat this procedure in turn for each regulator in the installation.

1. Slowly open the pilot supply line hand valve.
2. Slowly open the upstream block valve and partially open the downstream block valve for minimum flow.
3. Slowly open the hand valve in the control line and adjust the pilot setting if necessary. Set the monitoring regulator at a slightly higher control pressure than the working regulator.
4. Completely open the downstream block valve.
5. Slowly close the bypass valve, if any.

Shutdown

Installation arrangements vary, but in any installation it is important that the valves be opened or closed slowly and that the outlet pressure be vented before venting inlet pressure to prevent damage caused by reverse pressurization of the pilot or main valve. The following steps apply to the typical installation as indicated.

Single-Pilot, Dual-Pilot Regulator or Wide-Open Monitor

As well as applying to a single-pilot regulator (Figure 3), the steps in this procedure are also valid for a dual-pilot regulator (Figure 4) or a wide-open monitoring installation (Figure 7) and just need to be repeated for each regulator in such an installation.

1. Slowly close the downstream block valve. If the control line is downstream of the block valve, also close the hand valve in the control line.
2. Slowly close the upstream block valve and the hand valve in the pilot supply line.
3. Slowly open the vent valve in the downstream pipeline. If the control line is downstream of the block valve, also open the vent valve in the control line. Permit all pressure to bleed out.
4. Slowly open the upstream pipeline vent valve. Allow all pressure to bleed out of both the piping and the pilot.

Types 1098-EGR and 1098H-EGR

Working Monitor

1. Slowly close the downstream block valve and the hand valve in the downstream pressure control line.
2. Slowly close the upstream block valve and the hand valves in both pilot supply lines.
3. Slowly open all vent valves and permit all pressures to bleed out of the piping and regulators.

Maintenance

Regulator parts are subject to normal wear and must be inspected and replaced as necessary. The frequency of inspection and replacement of parts depends upon the severity of service conditions or the requirements of local, state and federal regulations. Due to the care Emerson™ takes in meeting all manufacturing requirements (heat treating, dimensional tolerances, etc.), use only replacement parts manufactured or furnished by Emerson.

The stem O-rings (key 6, Figure 13) on the Type 1098 or 1098H actuator should be lubricated during regularly scheduled maintenance, using the grease fitting (key 28, Figure 13). Stem O-rings can be checked for damage during normal operation by line pressure leakage or unexpected grease extrusion from the actuator vent (key 27, Figure 13). Unless otherwise specified, all O-rings, gaskets and seals should be lubricated with a good grade of general-purpose grease and installed gently rather than forced into position. Be certain that the nameplates (key 13, Figure 13) are updated to accurately indicate any field changes in equipment, materials, service conditions or pressure settings.



WARNING

To avoid personal injury resulting from sudden release of pressure, isolate the regulator from all pressure and cautiously release trapped pressure from the regulator before attempting disassembly.

Type EGR Main Valve

Replacing Quick-Change Trim Package

Perform this procedure if the entire trim package is replaced. Key numbers for both the complete main valve and its trim package are referenced in Figures 11 and 12. Some replacement trim package assembly numbers are listed in a table in the parts list.

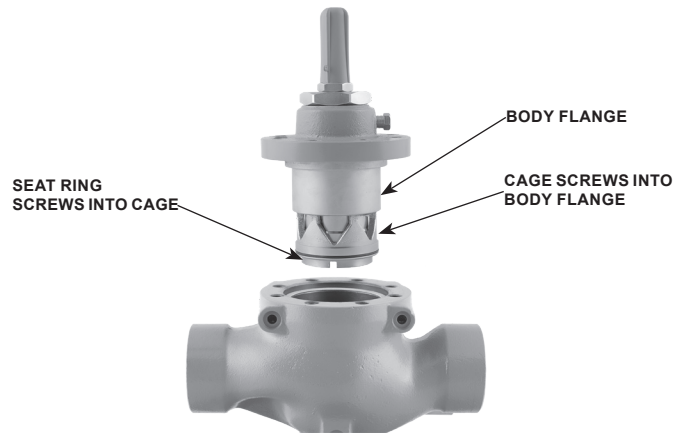

Figure 8. Trim Package Removal

Note

All disassembly, trim change and reassembly steps in this section may be performed with the regulator in the main line and without disconnecting the pilot supply or control lines.

1. Remove the cap screws (key 3) with a cast iron body or remove the stud bolt nuts (key 29, not shown) with a steel body. Pry the body flange (key 2) from the valve body (key 1) and lift out the trim package.
2. Perform any required inspection, cleaning or maintenance on the exposed surfaces of the valve body (key 1) or trim package. Replace the gasket (key 4) or cage O-ring (key 17) as necessary.
3. On a pre-built replacement trim package, check indicator zeroing by unscrewing the indicator protector (key 19) and seeing if the flange of the indicator nut (key 22) lines up evenly with the bottom marking on the indicator scale (key 18). If not, remove the indicator scale and separate the indicator nut and hex nut (key 8). Hold the indicator scale against the indicator fitting (key 5) with the scale base resting against the shoulder of the fitting and turn the indicator nut until its flange is aligned with the bottom scale marking. Then lock both nuts against each other and install the indicator scale and protector.
4. Coat the cage seating surface of the valve body (key 1) web and the body flange (key 2) seating surfaces of the valve body neck with a good grade of general-purpose grease. Install the trim package and secure it evenly with the cap screws (key 3) or stud bolt nuts (key 29, not shown).

No particular trim package orientation in the body is required.

Replacing Travel Indicator Assembly

When performing maintenance on the original Type 1098-EGR body flange, travel indicator replacement is recommended. The redesigned travel indicator assembly is incorporated into all Quick-Change Trim Kits and on the Travel Indicator Kits. The elastomer repair kits contain the components for the redesigned travel indicator assembly.

1. Remove the travel indicator assembly by removing lower indicator fitting (key 5) from the body flange (key 2).
2. Coat the threads of the lower indicator fitting (key 5) with a good grade of general-purpose grease.
3. Install travel indicator assembly (10C1212), torque to 40 ft-lbs / 54 N•m.
4. Check indicator zeroing by unscrewing the indicator protector (key 19) and seeing if the flange of the indicator nut (key 22) lines up evenly with the bottom marking on the indicator scale (key 18). If not, remove the indicator scale and separate the indicator nut and hex nut (key 8). Hold the indicator scale against the indicator fitting (key 5) with the scale base resting against the shoulder of the fitting and turn the indicator nut until its flange is aligned with the bottom scale marking. Then lock both nuts against each other and install the indicator scale and protector.

Replacing Trim Parts

Perform this procedure when inspecting, cleaning or replacing individual trim package parts. Key numbers are referenced in Figures 11 and 12.

Note

Access to the spring (key 9), flange O-ring, travel indicator parts or optional travel stop (key 32) in step 1 can be gained without removing the body flange (key 2).

1. Remove the travel indicator assembly by removing lower indicator fitting (key 5) from the body flange (key 2). Proceed to step 5 if maintenance on only the travel indicator parts is needed and then proceed to step 11 for reassembly instructions.
2. Remove the cap screws (key 3) on a cast iron body or remove the stud bolt nuts (key 29, not shown) on a steel body and pry the body flange (key 2) loose from the valve body (key 1).

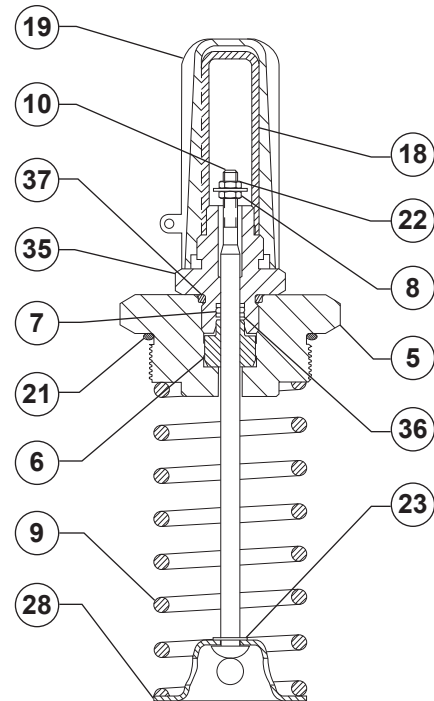

Figure 9. Types 1098-EGR and 1098H-EGR Travel Indicator Assembly

3. Use the valve body (key 1) as a holding fixture if desired. Flip the body flange (key 2) over and anchor it on the valve body as shown in Figure 10, removing the pipe plug (key 31) first if necessary.
4. To gain access to the port seal (key 12), upper seal (key 15) or valve plug (key 16) part, unscrew the seat ring (key 13) from the cage (key 11) and the cage from the body flange (key 2). For leverage, a wrench handle or similar tool may be inserted into the seat ring slots (Figure 10) and a strap wrench may be wrapped around a standard or a Whisper Trim™ Cage or a soft bar may be inserted through the windows of a standard cage. To remove the piston ring (key 14) and/or plug O-ring (key 20), remove the valve plug (key 16) from the body flange, insert a screwdriver into the precut fold over area of the piston ring and unfold the piston ring. Proceed to step 6 if no further maintenance is necessary.
5. To gain access to a part in the travel indicator assembly, remove the indicator protector (key 19) and indicator scale (key 18). Since some compression is left in the spring, carefully remove the flanged nut (key 22) and hex nut (key 8). A screwdriver may be inserted through the press-fit bushing (key 6) to remove the stem O-ring without removing the bushing. If necessary, unscrew the travel stop (if used) and unclip the E-ring from the indicator stem.

Types 1098-EGR and 1098H-EGR

Table 8. Type EGR Main Valve Cap Screw (key 3) Torque

SIZE		TORQUE	
NPS	DN	Ft-lbs	N•m
1	25	75 to 95	102 to 129
2	50	55 to 70	75 to 95
3	80	100 to 130	136 to 176
4	100	160 to 200	217 to 271
6, 8 x 6, 1 2 x 6	150, 200 x 150, 300 x 150	275 to 300	373 to 407

6. Thoroughly clean and inspect all parts before reassembling.
7. Apply a minimal amount (2 to 3 drops) of silicon oil to the port seal (key 12) and install it flat side down in the gland in the seat ring (key 13). Run a finger around the port seal (key 12) until it is completely flat to remove any trapped air. Lubricate the seat ring threads and firmly tighten the seat ring (key 13) into the cage (key 11) using a bar. Use a back and forth motion during tightening to ensure the seal doesn't wrinkle. As a final step once snug, back out the seat ring (key 13) by a few degrees of rotation.
8. Install the plug O-ring (key 20) and piston ring (key 14) onto the valve plug (key 16). Insert the valve plug into the body flange (key 2).
9. Apply a minimal amount (2 to 3 drops) of silicon oil to the upper seal (key 15) and install it flat side down in the gland in the cage (key 11). Run a finger around the upper seal (key 15) until it is completely flat to remove any trapped air. Lubricate the cage threads and using a bar or strap wrench, firmly tighten the cage (key 11) into the body flange (key 2). Use a back and forth motion during tightening to ensure the seal doesn't wrinkle. As a final step once snug, back out the cage (key 11) by a few degrees of rotation.
10. Remove the upside-down body flange (key 2) if it was anchored on the body. Coat the cage (key 11) seating surfaces of the valve body (key 1) web and the body flange (key 2) seating surfaces of the valve body neck with a good grade of general-purpose grease. Install the body flange on the body and secure it evenly with the cap (key 3) screws or stud bolt nuts (key 29, not shown). Except on the NPS 1 / DN 25 body, which does not use it, the pipe plug (key 31) must be installed in the side tapping of the flange for proper operation.

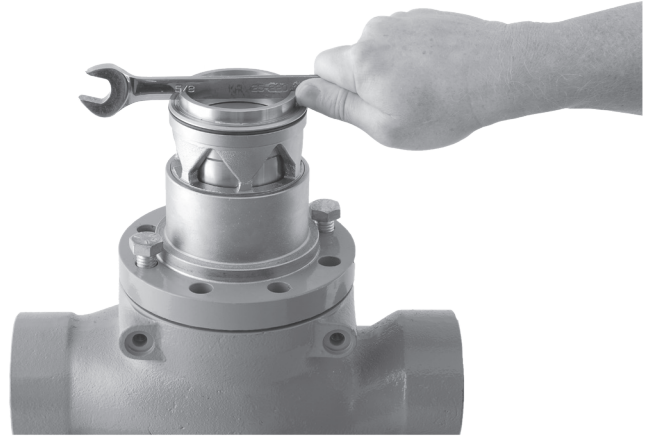

Figure 10. Seat Ring / Cage Removal Using Body as Holding Fixture

11. Make sure that the flange (key 2) and stem O-rings (key 7) and the bushings are installed in the indicator fitting (key 5). Orient the spring seat (key 28) as shown in Figure 11 and attach it with the E-ring (key 23) to the slotted end of the indicator stem (key 10). Install the travel stop (key 32) (if used) on the spring seat and then install the spring (key 9).
12. Being careful not to cut the stem O-ring (key 7) with the stem threads, install the indicator fitting (key 5) down over the indicator stem (key 10) until resting on the spring (key 9). Install the hex nut (key 8) and then the flanged indicator nut (key 22) on the indicator stem, pushing on the fitting if necessary to provide sufficient stem thread exposure. To maintain clearance for indicator part installation, draw up the spring seat (key 28) by turning the hex nut down on the stem until the threads bottom.
13. Install the indicator fitting (key 5) with attached parts into the body flange (key 2). Back the hex nut off until the spring completely closes the valve plug (key 16) against the port (key 12) and upper seals (key 15), as indicated by stem threads showing between this nut and the fitting. Hold the indicator scale (key 18) against the fitting with the scale base resting against the shoulder of the fitting and turn the indicator nut (key 22) until its flange is aligned with the bottom scale marking. Then lock both nuts against each other and install the indicator scale and protector (key 19).

P590 Series Filter

Perform this procedure to clean or replace filter parts in a standard Type P593-1 or P594-1 filter assembly. Remove the following (as shown in Figure 14): filter body (key 1), machine screw (key 4), gasket (key 7), two flat washers (key 5) and filter element (key 2).

Upon reassembly, one of the flat washers must go between the filter element and filter head (key 3) and the other must go between the filter element and gasket. Use a good grade of pipe thread sealant on the filter head pipe threads.

Type 6351 Pilot

Perform this procedure if changing the control spring for one of a different range or if inspecting, cleaning or replacing any other pilot parts. Pilot key numbers are referenced in Figure 15 and mounting key numbers in Figure 23, 24, 25 or 27.

Note

The body assembly (key 1) may remain on the pipe nipple (key 23, Figure 23 or key 39, Figure 27) unless the entire pilot is replaced.

1. To gain access to the diaphragm assembly (key 7), control spring (key 9) or spring seat (key 8), loosen the locknut (key 11) and turn the adjusting screw (key 10) counterclockwise until compression is removed from the spring. Remove the machine screws (key 12) and separate the body assembly (key 1) from the bonnet (key 2).
2. Inspect the removed parts and replace as necessary. Ensure the registration and bleed holes in the pilot body are free of debris. After assembly, make sure of the proper control spring setting according to the Startup section and remark the spring case if necessary.
3. To replace the valve plug (key 4), remove the body plug (key 3) to let the valve spring (key 6) and inner valve assembly (key 4) drop freely from the body (key 1). Inspect the removed parts, replace if necessary. Make sure the plug seating surfaces are free from debris. Inspect body plug O-ring (key 3), replace if necessary. Type 6351 pilots manufactured before May 1999 need to have the

body plug gasket and the body plug replaced with a new body plug assembly (key 3), which includes the body plug and the body plug O-ring. Install the body plug O-ring over the body plug. Stack the valve spring and the inner valve assembly on the body plug assembly (key 3) and install the body plug assembly with stacked parts into the body.

Types 6352 through 6354M Pilots

Perform this procedure if changing the control spring for one of a different range or if inspecting, cleaning or replacing any other pilot parts. Pilot part key numbers are referenced in Figure 16. Mounting key numbers are referenced in Figure 23 for single-pilot constructions and in Figures 25 and 27 for dual-pilot constructions.

Note

The body (key 1) may remain on the pipe nipple (key 23, Figure 23 or key 39, Figure 27) unless the entire pilot is replaced.

1. To gain access to the diaphragm assembly (key 5), diaphragm limiter (key 23) if used, control spring (key 6), restriction (key 22), stem guide (key 8) or spring seat (key 7), remove the closing cap (key 11), loosen the locknut (key 10) and turn the adjusting screw (key 9) counterclockwise until compression is removed from the spring. Remove the machine screws (key 14) and separate the body from the spring case (key 2).
2. Inspect the removed parts and replace as necessary. Make sure the restriction and the registration hole in the body are free from debris. After assembly, make sure of the proper control spring setting according to the Startup section and remark the spring case if necessary.
3. To replace the valve plug (key 4) or bellows O-ring (key 17), remove the body plug (key 3) and body plug gasket (key 12). Be careful to keep the bellows assembly (key 16) from falling out and possibly getting lost while removing the valve plug. Inspect the removed parts and replace as necessary. Make sure the valve plug seating surfaces are free from debris.

Types 1098-EGR and 1098H-EGR

61 Series Pilot and Type 1806 Check Valve

Perform this procedure if changing the control spring for one of a different range or if inspecting, cleaning or replacing check valve or any other pilot parts. Pilot part key numbers are referenced in Figures 17 and 18 and mounting part and check valve key numbers in Figure 24.

1. Remove the pilot from the pipe nipple (key 24) unless just the control spring is to be changed.
2. To gain access to the control spring or other internal parts, remove the closing cap assembly (key 5) and relieve control spring (key 7) compression by turning the adjusting screw (key 6) counterclockwise. Change the control spring and install the adjusting screw and closing cap assembly if no other maintenance will be performed. Make sure of the proper control spring setting according to the Installation and Startup section and restamp the nameplate if necessary.
3. For any other internal maintenance, relieve control spring compression according to step 2. Then remove the cap screw (key 20) and separate the pilot into three sections: spring case (key 1), body (key 2) and bottom cover (key 3).
4. To inspect the two diaphragms (keys 14 and 15) thoroughly, remove the diaphragm nut (key 11), hex nut (key 19) and the upper and lower relay heads (keys 16 and 17). The projecting prong in the body may be used as the restraining member to keep the yoke (key 4) from turning while removing the nuts. Also inspect the O-ring (key 12) and replace any parts as necessary.
5. Take the yoke (key 4) and attached parts out of the body to examine the disk holder assembly (key 9). Remove the relay orifice (key 8) to check for clogging and replace if necessary.
6. To replace the disk holder assembly, first unscrew the bleed orifice (key 10). Remove it and the associated parts. Then unscrew the disk (key 9) holder assembly from the bleed valve (key 26) to gain access to the relay spring (key 13). Clean or replace any parts as necessary before reassembling.
7. Upon reassembly, pay particular attention to the following assembly suggestions:
 - a. Before replacing the diaphragm case (key 2) or spring case (key 1), be sure the yoke assembly is positioned so that it will not bind or rub on the prong in the relay body.
 - b. Avoid wrinkling the diaphragms (key 14 and 15) when replacing the diaphragm case (key 2) and spring case (key 1).
 - c. Replace the diaphragm case (key 2), carefully working the upper relay diaphragm (key 14) into the recess in the diaphragm case. If the diaphragm case rocks with respect to the pilot body, the diaphragm is probably wrinkled.
 - d. Replace the spring case (key 1), using care to smooth the lower relay diaphragm (key 15) evenly into the recess in the pilot body.
 - e. Install the eight cap screws (key 20), tightening them down evenly in a crisscross pattern to avoid crushing the diaphragm. Recommended final torque on these cap screws is 10 to 12 ft-lbs / 14 to 16 N•m.
8. After assembly, make sure of the proper control spring setting according to the Installation and Startup section and restamp the nameplate (key 27) if necessary.
9. To gain access to the Type 1806 check valve, disconnect the tubing at the connector fitting and unscrew the check valve. Make sure the spring closes the ball or replace the check valve if necessary. Install the check valve back in the pipe tee (key 16) and reconnect the tubing (key 18) and connector fitting.

Type Y600AM Pilot

Body Area

This procedure is for gaining access to the disk assembly, orifice and body O-ring. All pressure must be released from the diaphragm casing and the disk assembly must be open, before these steps can be performed. Part key numbers are referenced in Figure 20.

1. Remove the cap screws (key 2) and separate the diaphragm casing (key 4) from the body (key 1).
2. Remove and inspect the body seal O-ring (key 11) and the backup ring (key 48).
3. Inspect and replace the orifice (key 5) if necessary. Protect the orifice seating surface during disassembly and assembly. Lubricate the threads of the replacement orifice with proper amount of anti-seize lubricant and install with 29 to 38 ft-lbs / 39 to 52 N•m of torque.

Types 1098-EGR and 1098H-EGR

4. To replace the disk assembly (key 13), remove the cotter pin (key 15). If not necessary, skip to step 7.
5. Install the disk assembly (key 13) and secure it with the cotter pin (key 15).
6. Place backup ring (key 48) into the body (key 1). Then place the body seal O-ring (key 11) into the body.
7. Place the diaphragm casing (key 4) on the body (key 1). Secure the the diaphragm casing to the body with the cap screws (key 2) using 7 to 9 ft-lbs / 9.5 to 12 N•m.
6. Install the lever assembly (key 16) into the stem (key 14) and secure the lever assembly with the machine screws (key 17).
7. Hold the pusher post (key 8) and place diaphragm assembly parts on the pusher post in the following order: diaphragm (key 10), diaphragm head (key 7), lower spring seat (key 50) and washer (key 36) and secure with diaphragm cap screw (key 38) using 7 to 9 ft-lbs / 9.5 to 12 N•m of torque.
8. Install the pusher post (key 8) and attached parts onto the lever (key 16).
9. Install the control spring (key 6) and spring case (key 3) on the diaphragm casing (key 4) so that the vent assembly (key 26) is correctly oriented and secure them with the cap screws (key 24) and hex nuts (key 23) to finger tightness only.

Diaphragm and Spring Case Area

This procedure is for gaining access to the spring, diaphragm, lever assembly stem and Type Y600AM stem O-ring. All pressure must be released from the diaphragm casing before performing these steps.

1. Remove the closing cap (key 22) and turn the adjusting screw (key 35) counterclockwise to remove the compression from the spring (key 6).
2. If the only maintenance is to change the control spring, take out the control spring and replace with the desired spring. Turn the adjusting screw (key 35) clockwise to compress the spring to the desired outlet pressure setting according to the Installation and Startup section and restamp the nameplate if necessary. Skip to step 11.
3. If further maintenance to the internal diaphragm casing parts is required, remove the hex nuts (key 23, not shown) and cap screws (key 24). Remove the diaphragm (key 10) plus attached parts by tilting them so that the pusher post (key 8) slips off the lever assembly (key 16). To separate the diaphragm from the attached parts, unscrew the cap screw (key 38) from the pusher post (key 8). If the only maintenance needed is to replace the diaphragm parts, skip to step 7.
4. To replace the lever assembly (key 16), remove the machine screws (key 17). To replace the stem (key 14) or stem O-ring (key 30), also perform Body Area Maintenance procedure steps 1 and 4 and pull the stem (key 14) out of the diaphragm casing (key 4). Grease the replacement stem O-ring (key 30) with a good grade of lubricant and install it on the stem (key 14).
5. Install the stem (key 14) into the diaphragm casing (key 4) and perform Body Area Maintenance procedure steps 6 through 8 as necessary.
10. Turn the adjusting screw (key 35) clockwise until there is enough control spring (key 6) force to provide proper slack to the diaphragm (key 10). Using a crisscross pattern, finish tightening the cap screws (key 24) and hex nuts to 5 to 6 ft-lbs / 6.8 to 8.1 N•m of torque. Finish turning the adjusting screw to the desired outlet pressure setting.
11. Install the closing cap (key 22).

Type MR95H Supply Pressure Regulator

This section includes instructions for disassembly and assembly of replacement parts. All key numbers refer to Figure 22.

1. Unscrew the valve plug guide (key 5) from the body (key 1). The valve plug spring (key 10) and the valve plug (key 4) will normally come out of the body along with the valve plug guide.
2. Inspect the seating surface of the valve plug (key 4), being sure that the composition surface (or polished steel surface) of the valve plug is not damaged. Replace if damaged.
3. Inspect the seating edge of the orifice (key 3). If damaged, unscrew the orifice from the body and replace it with a new part. If no further maintenance is required, reassemble the regulator in the reverse of the above steps. When installing the valve plug guide (key 5) coat the threads and sealing surface with sealant to ensure an adequate metal-to-metal seal.

Types 1098-EGR and 1098H-EGR

- To inspect the diaphragm (key 12) or other internal parts, loosen the locknut (key 17) and turn the adjusting screw (key 15) to remove all spring compression.
- Remove the diaphragm case cap screws (key 16) and lift off the spring case (key 2). Remove the upper spring seat (key 9) and regulator spring (key 11). Remove the lower spring seat (key 8).
- Remove the diaphragm (key 12) and examine for damage. Replace if damaged.
- With diaphragm removed, check to be sure the pressure registration hole is completely open and free of all obstructions.
- Reassemble in reverse order of the previous steps. Lubricate the upper spring seat (key 9) and the exposed threads of the adjusting screw (key 15). Before tightening cap screws (key 16) be sure to install the adjusting screw, if completely removed and turn it down to obtain diaphragm slack. This allows proper positioning of the diaphragm to permit full travel of the valve plug (key 4). Complete reassembly procedures and temporarily install a gauge in place of the pipe plug (key 52). Turn the adjusting screw to produce the desired outlet pressure values shown in Table 2. Tighten the locknut to maintain the desired setting.
- Remove the cap screws (key 10), nuts (key 11), lower diaphragm case (key 1), diaphragm (key 7) and diaphragm plate (key 8). To separate the stem (key 12) from the diaphragm plate (key 8), remove the stem cap screw (key 9).
- To remove the Type 1098 case O-ring** (key 5), unscrew the four case cap screws (key 4), remove the upper diaphragm case (key 2) and remove the case O-ring.
To remove the Types 1098 and 1098H stem O-rings (key 6), remove the pilot(s) and pipe nipple(s) if necessary. Unscrew either the Type 1098 bonnet (key 3) or the Type 1098H upper diaphragm case (key 2) and remove the wiper ring, bearings and O-rings.
- Lubricate both stem O-rings (key 6) and wiper ring (key 57) and install them with the stem bearings (key 56) in either the Type 1098 bonnet (key 3) or in the Type 1098H upper diaphragm case (key 2).
- For the Type 1098H actuator**, thread the upper diaphragm casing (key 2) into the main valve body.

For the Type 1098 actuator, lubricate the case O-ring (key 5) and install it in the bonnet (key 3). Line up the holes in the upper diaphragm casing (key 2) and the bonnet; insert and tighten the four case cap screws (key 4) to secure the parts together. Thread the bonnet into the main valve body.

Types 1098 and 1098H Actuator and Pilot Mounting Parts

Perform this procedure if changing the actuator or inspecting, cleaning or replacing actuator and/or pilot mounting parts. Actuator part key numbers are referenced in Figure 13 and mounting part numbers in Figure 26, unless otherwise indicated.

- The actuator and pilot(s) may be removed and replaced as a unit by disconnecting the control line and pilot supply line.
- Access to all internal parts except the stem O-rings, bearings and wiper (keys 6, 56 and 57) may be gained without removing the bonnet (key 3) or upper diaphragm case (key 2) from the main valve or the pilot(s) from the bonnet pipe nipple (key 23, Figure 23 or keys 37 and 39, Figure 27). Disconnect the loading tubing (key 24, Figure 23, 25 or 27) from the actuator elbow fitting (key 25, Figure 23 or key 41, Figure 27) and with a Type 61LD pilot also disconnect the tubing (key 18, Figure 24) from the fitting tee.
- Secure the diaphragm plate (key 8) to the stem (key 12) with the stem cap screw (key 4). Lay the entire diaphragm (key 7), diaphragm plate and stem assembly into the lower diaphragm case (key 1) so the diaphragm convolution laps up over the diaphragm plate according to Figure 13. Then install the stem slowly up into the bonnet (key 3) to prevent stem or O-ring damage and secure the lower diaphragm case to the upper diaphragm case (key 2) with the cap screws and nuts. Tighten the cap screws and nuts evenly in a crisscross pattern to avoid crushing the diaphragm.
- Grease the stem O-rings through the zerk fitting (key 28) until excess grease emerges from the vent (key 27).
- Install the pipe nipple(s) and pilot(s) if they were removed during maintenance. Connect the actuator loading tubing if it was disconnected.

Types 1098-EGR and 1098H-EGR

Parts Ordering

Each Type 1098-EGR or 1098H-EGR regulator is assigned a serial number or FS number which can be found on the nameplates. Refer to this number when contacting your local Sales Office for assistance or when ordering replacement parts.

When ordering a replacement part, be sure to include the complete 11-character part number from the following parts list. Some commonly used trim packages can be ordered according to the 11-character assembly number given in the parts kits listed in the Parts List.

Parts List

Note

Except where indicated, sizes shown are valve body sizes.

Type EGR Main Valve (Figures 11 and 12)

Key	Description	Part Number
	Elastomer Trim Parts kit (included are: keys 4, 7, 12, 14, 15, 17, 20, 21, 36 and 37)	
	Nitrile (NBR)	
	NPS 1 / DN 25	R63EGX00112
	NPS 2 / DN 50	R63EGX00122
	NPS 3 / DN 80	R63EGX00132
	NPS 4 / DN 100	R63EGX00142
	NPS 6 / DN 150	R63EGX00162
	Fluorocarbon (FKM)	
	NPS 1 / DN 25	R63EGXFK112
	NPS 2 / DN 50	R63EGXFK122
	NPS 3 / DN 80	R63EGXFK132
	NPS 4 / DN 100	R63EGXFK142
	NPS 6 / DN 150	R63EGXFK162
	Ethylpropylene (EPR)	
	NPS 1 / DN 25	R63EGXEP112
	NPS 2 / DN 50	R63EGXEP122
	NPS 3 / DN 80	R63EGXEP132
	NPS 4 / DN 100	R63EGXEP142
	NPS 6 / DN 150	R63EGXEP162
	Actuator Parts kit (included are: keys 5, 6, 7, 56 and 57)	
	Size 30	
	Nitrile (NBR)	R1098X00302
	Fluorocarbon (FKM)	R1098X00502
	Size 40	
	Nitrile (NBR)	R1098X00402
	Fluorocarbon (FKM)	R1098X00602
	Size 70	
	Nitrile (NBR)	R1098X00702
	Quick Change Trim Kit for Linear Cage (see Figure 12 for included keys)	
	60 psi / 4.1 bar spring color green	
	Cast Iron Body Flange	
	NPS 1 / DN 25	25A3170X012
	NPS 2 / DN 50	25A3170X102
	NPS 3 / DN 80	25A3170X152
	NPS 4 / DN 100	25A3170X222
	NPS 6 / DN 150	25A3170X272

Key	Description	Part Number
	Quick Change Trim Kit (see Figure 12 for included keys)	
	60 psi / 4.1 bar spring color green (continued)	
	Steel Body Flange	
	NPS 1 / DN 25	25A3170X422
	NPS 2 / DN 50	25A3170X452
	NPS 3 / DN 80	25A3170X372
	NPS 4 / DN 100	25A3170X482
	NPS 6 / DN 150	25A3170X512
	NPS 8 x 6 / DN 200 x 150	25A3170X532
	125 psi / 8.6 bar spring color blue	
	Cast Iron Body Flange	
	NPS 1 / DN 25	25A3170X032
	NPS 2 / DN 50	25A3170X082
	NPS 3 / DN 80	25A3170X142
	NPS 4 / DN 100	25A3170X192
	NPS 6 / DN 150	25A3170X282
	Steel Body Flange	
	NPS 1 / DN 25	25A3170X432
	NPS 2 / DN 50	25A3170X382
	NPS 3 / DN 80	25A3170X462
	NPS 4 / DN 100	25A3170X492
	NPS 6 / DN 150	25A3170X342
	NPS 8 x 6 / DN 200 x 150	25A3170X542
	400 psi / 27.6 bar spring color red	
	Cast Iron Body Flange	
	NPS 1 / DN 25	25A3170X052
	NPS 2 / DN 50	25A3170X112
	NPS 3 / DN 80	25A3170X172
	NPS 4 / DN 100	25A3170X242
	NPS 6 / DN 150	25A3170X312
	Steel Body Flange	
	NPS 1 / DN 25	25A3170X442
	NPS 2 / DN 50	25A3170X332
	NPS 3 / DN 80	25A3170X472
	NPS 4 / DN 100	25A3170X502
	NPS 6 / DN 150	25A3170X522
	NPS 8 x 6 / DN 200 x 150	25A3170X552
	Parts Kit, Quick Change Travel Indicator Kit (included are: keys 10, 6, 35, 5, 8, 7 and 36 (2 required); keys 21, 18, 22, 23, 37, 19, 28 and 9)	
	20 psi / 1.4 bar spring color yellow	
	NPS 2 / DN 50	10C1212X162
	NPS 3 / DN 80	10C1212X172
	NPS 4 / DN 100	10C1212X182
	NPS 6 / DN 150	10C1212X192
	60 psi / 4.1 bar spring color green	
	NPS 1 / DN 25	10C1212X042
	NPS 2 / DN 50	10C1212X012
	NPS 3 / DN 80	10C1212X022
	NPS 4 / DN 100	10C1212X032
	NPS 6 / DN 150	10C1212X052
	125 psi / 8.6 bar spring color blue	
	NPS 1 / DN 25	10C1212X092
	NPS 2 / DN 50	10C1212X062
	NPS 3 / DN 80	10C1212X072
	NPS 4 / DN 100	10C1212X082
	NPS 6 / DN 150	10C1212X102
	400 psi / 27.6 bar spring color red	
	NPS 1 / DN 25	10C1212X142
	NPS 2 / DN 50	10C1212X112
	NPS 3 / DN 80	10C1212X122
	NPS 4 / DN 100	10C1212X132
	NPS 6 / DN 150	10C1212X152
	1	Valve Bodies
	2	Body Flange
		Cast iron, ENC ⁽¹⁾
		NPS 2 / DN 50
		NPS 3 / DN 80
		NPS 4 / DN 100
		NPS 6, 8 x 6 or 12 x 6 / DN 150, 200 x 150 or 300 x 150
		See following table
		25A3168X012
		24A9034X012
		25A2309X012
		34A8172X012

- continued -

Types 1098-EGR and 1098H-EGR

Type EGR Main Valve (Figures 11 and 12) (continued)

Key	Description	Part Number
2	Body Flange (continued) WCC steel, ENC, heat-treated ⁽¹⁾ NPS 1 / DN 25 NPS 2 / DN 50 NPS 3 / DN 80 NPS 4 / DN 100 NPS 6, 8 x 6 or 12 x 6 / DN 150, 200 x 150 or 300 x 150 CF8M Stainless steel, ENC (NACE) NPS 1 / DN 25 NPS 2 / DN 50 NPS 3 / DN 80 NPS 4 / DN 100 NPS 6, 8 x 6 or 12 x 6 / DN 150, 200 x 150 or 300 x 150	24A6779X012 25A2254X012 25A2300X012 24A9032X012 34A7152X012 24A6779X062 25A2254X082 25A2300X122 24A9032X042 34A7152X052
3	Cap Screw, plated steel (use with Cast iron and Steel body) NPS 1 / DN 25 (4 required) NPS 2 / DN 50 (8 required) NPS 3 / DN 80 (8 required) NPS 4 / DN 100 (8 required) NPS 6, 8 x 6 or 12 x 6 / DN 150, 200 x 150 or 300 x 150 (12 required)	1R281124052 1A453324052 1A454124052 1A485724052 1U513124052
3	Stud Bolt, Stainless steel (use with Stainless steel body) (not shown) NPS 1 / DN 25 (4 required) NPS 2 / DN 50 (8 required) NPS 3 / DN 80 (8 required) NPS 4 / DN 100 (8 required) NPS 6, 8 x 6 or 12 x 6 / DN 150, 200 x 150 or 300 x 150 (12 required)	1R284835222 1K242935222 1A378135222 1R369035222 1A365635222
4*(1)	Gasket, composition NPS 1 / DN 25 NPS 2 / DN 50 NPS 3 / DN 80 NPS 4 / DN 100 NPS 6, 8 x 6 or 12 x 6 / DN 150, 200 x 150 or 300 x 150	14A6785X012 14A5685X012 14A5665X012 14A5650X012 14A6984X012
5(1)	Travel Indicator Fitting Zinc-plated steel NPS 1 / DN 25 NPS 1 / DN 25 (NACE) NPS 2, 3 or 4 / DN 50, 80 or 100 NPS 6, 8 x 6 or 12 x 6 / DN 150, 200 x 150 or 300 x 150 (NACE) Stainless steel NPS 2, 3 or 4 / DN 50, 80 or 100 (NACE)	T21117T0012 T21117T0022 T21107T0012 T21120T0012 T21107T0022
6(1)	O-ring Retainer Stainless steel (NACE)	T14276T0012
7*(1)	Travel Indicator Stem O-ring Nitrile (NBR) ⁽¹⁾ Fluorocarbon (FKM) Ethylene propylene (EPR) Perfluorocarbon (FFKM)	1E472706992 1N430406382 1D6875X0092 1D6875X0082
8(1)	Travel Indicator Hex Nut, plated steel	1A662228992
9(1)	Spring, steel (standard) or Inconel® X-750 (NACE) See following table	
10(1)	Travel Indicator Stem 18-8 Stainless steel NPS 1 / DN 25 NPS 2 / DN 50 NPS 3 / DN 80 NPS 4 / DN 100 NPS 6, 8 x 6 or 12 x 6 / DN 150, 200 x 150 or 300 x 150	T14311T0012 T14275T0012 T14312T0012 T14313T0012 T14314T0012

Key	Description	Part Number
10(1)	Travel Indicator Stem (continued) 316 Stainless steel (NACE) NPS 1 / DN 25 NPS 2 / DN 50 NPS 3 / DN 80 NPS 4 / DN 100 NPS 6, 8 x 6 or 12 x 6 / DN 150, 200 x 150 or 300 x 150	T14311T0022 T14275T0022 T14312T0022 T14313T0022 T14314T0022
11	Cage Linear ⁽¹⁾ , CF8M Stainless steel (NACE) NPS 1 / DN 25 NPS 2 / DN 50 NPS 3 / DN 80 NPS 4 / DN 100 NPS 6, 8 x 6 or 12 x 6 / DN 150, 200 x 150 or 300 x 150 Whisper Trim® 416 Stainless steel NPS 1 / DN 25 NPS 2 / DN 50 NPS 3 / DN 80 NPS 4 / DN 100 NPS 6, 8 x 6 or 12 x 6 / DN 150, 200 x 150 or 300 x 150 316 Stainless steel, ENC NPS 1 / DN 25 NPS 2 / DN 50 NPS 3 / DN 80 NPS 4 / DN 100 NPS 6, 8 x 6 or 12 x 6 / DN 150, 200 x 150 or 300 x 150 Whisper Trim® 55% Capacity, Stainless steel (NACE), NPS 2 / DN 50 Quick Opening, 316 Stainless steel NPS 1 / DN 25 NPS 2 / DN 50 NPS 3 / DN 80 NPS 4 / DN 100 NPS 6, 8 x 6 or 12 x 6 / DN 150, 200 x 150 or 300 x 150	34B4136X012 34B5838X012 34B5839X012 34B5840X012 34B5841X012 24A2043X012 24A5707X012 24A5708X012 24A5709X012 24A8174X012 24A2043X022 24A5707X022 24A5708X042 24A5709X022 24A8174X022 37B7874X022 GF03315X012 GF03319X012 GF03311X012 GF03314X012 37A7215X032
12*	Port Seal Nitrile (NBR) ⁽¹⁾ (standard) NPS 1 / DN 25 NPS 2 / DN 50 NPS 3 / DN 80 NPS 4 / DN 100 NPS 6, 8 x 6 or 12 x 6 / DN 150, 200 x 150 or 300 x 150 Fluorocarbon (FKM) NPS 1 / DN 25 NPS 2 / DN 50 NPS 3 / DN 80 NPS 4 / DN 100 NPS 6, 8 x 6 or 12 x 6 / DN 150, 200 x 150 or 300 x 150 Ethylene propylene (EPR) NPS 1 / DN 25 NPS 2 / DN 50 NPS 3 / DN 80 NPS 4 / DN 100 NPS 6, 8 x 6 or 12 x 6 / DN 150, 200 x 150 or 300 x 150 Perfluorocarbon (FFKM) NPS 1 / DN 25 NPS 2 / DN 50 NPS 3 / DN 80 NPS 4 / DN 100 NPS 6, 8 x 6 or 12 x 6 / DN 150, 200 x 150 or 300 x 150	14A6788X012 24A5673X012 24A5658X012 24A5643X012 14A8175X012 14A8186X012 25A7412X012 25A7375X012 25A7469X012 14A6996X012 14A6788X022 24A5673X062 24A5658X062 24A5643X052 14A8175X022 14A6788X042 24A5673X082 24A5658X052 24A5643X032 14A8175X042

- continued -

1. Part included in trim package assembly can be ordered according to the parts kit trim package.

Types 1098-EGR and 1098H-EGR

Type EGR Main Valve (Figures 11 and 12) (continued)

Key	Description	Part Number	Key	Description	Part Number
13*(1)	Seat Ring		15*	Upper Seal (continued)	
	416 Stainless steel			Perfluorocarbon (FFKM)	
	NPS 1 / DN 25, 1-5/16 in. / 33 mm port	24A6781X012		NPS 1 / DN 25	14A6789X042
	NPS 2 / DN 50, 2-3/8 in. / 60 mm port	24A5670X012		NPS 2 / DN 50	24A5674X082
	NPS 3 / DN 80, 3-3/8 in. / 86 mm port	24A5655X012		NPS 3 / DN 80	24A5659X052
	NPS 4 / DN 100, 4-3/8 in. / 111 mm port	24A5640X012		NPS 4 / DN 100	24A5644X032
	NPS 6 / DN 150, 7-3/16 in. / 183 mm port	24A6989X012		NPS 6, 8 x 6 or 12 x 6 /	
	NPS 8 x 6 / DN 200 x 150, 7-3/16 in. /			DN 150, 200 x 150 or 300 x 150	14A8176X042
	183 mm port	38A4216X012	16*(1)	Valve Plug	
	316 Stainless steel (NACE)			416 Stainless steel	
	NPS 1 / DN 25, 1-5/16 in. / 33 mm port	24A6781X022		NPS 1 / DN 25	14A6780X012
	NPS 2 / DN 50, 2-3/8 in. / 60 mm port	24A5670X022		NPS 2 / DN 50	24A6772X012
	NPS 3 / DN 80, 3-3/8 in. / 86 mm port	24A5655X022		NPS 3 / DN 80	24A9421X012
	NPS 4 / DN 100, 4-3/8 in. / 111 mm port	24A5640X022		NPS 4 / DN 100	24A8182X012
	NPS 6 / DN 150, 7-3/16 in. / 183 mm port	24A6989X022		NPS 6, 8 x 6 or 12 x 6 /	
	NPS 8 x 6 / DN 200 x 150, 7-3/16 in. /			DN 150, 200 x 150 or 300 x 150	24A6992X012
	183 mm port	38A4216X022		316 Stainless steel (NACE)	
14*(1)	Piston Ring			NPS 1 / DN 25	14A6780X022
	NPS 1 / DN 25, PTFE (clear)	14A6786X012		NPS 2 / DN 50	24A6772X032
	NPS 2 / DN 50, PTFE (clear)	14A5675X012		NPS 3 / DN 80	24A9421X022
	NPS 3 / DN 80, PTFE (clear)	14A5660X012		NPS 4 / DN 100	24A8182X022
	NPS 4 / DN 100, PTFE (clear)	14A5645X012		NPS 6, 8 x 6 or 12 x 6 /	
	NPS 6, 8 x 6 or 12 x 6 / DN 150, 200 x 150			DN 150, 200 x 150 or 300 x 150	24A6992X022
	or 300 x 150, glass-filled, PTFE	14A6985X022	17*	Cage O-ring	
15*	Upper Seal			Nitrile (NBR) ⁽¹⁾ (standard)	
	Nitrile (NBR) ⁽¹⁾ (standard)			NPS 1 / DN 25	10A7777X012
	NPS 1 / DN 25	14A6789X012		NPS 2 / DN 50	10A7779X012
	NPS 2 / DN 50	24A5674X012		NPS 3 / DN 80	14A5688X012
	NPS 3 / DN 80	24A5659X012		NPS 4 / DN 100	10A3481X012
	NPS 4 / DN 100	24A5644X012		NPS 6, 8 x 6 or 12 x 6 /	
	NPS 6, 8 x 6 or 12 x 6 /			DN 150, 200 x 150 or 300 x 150	18A2556X022
	DN 150, 200 x 150 or 300 x 150	14A8176X012		Fluorocarbon (FKM)	
	Fluorocarbon (FKM)			NPS 1 / DN 25	10A7778X012
	NPS 1 / DN 25	14A8187X012		NPS 2 / DN 50	10A7779X022
	NPS 2 / DN 50	25A7413X012		NPS 3 / DN 80	14A5688X022
	NPS 3 / DN 80	25A7376X012		NPS 4 / DN 100	10A3483X012
	NPS 4 / DN 100	25A7468X012		NPS 6, 8 x 6 or 12 x 6 /	
	NPS 6, 8 x 6 or 12 x 6 /			DN 150, 200 x 150 or 300 x 150	18A2556X032
	DN 150, 200 x 150 or 300 x 150	14A8185X012		Ethylene propylene (EPR)	
	Ethylene propylene (EPR)			NPS 1 / DN 25	10A7777X022
	NPS 1 / DN 25	14A6789X022		NPS 2 / DN 50	10A7779X052
	NPS 2 / DN 50	24A5674X062		NPS 3 / DN 80	14A5688X082
	NPS 3 / DN 80	24A5659X062		NPS 4 / DN 100	10A3481X052
	NPS 4 / DN 100	24A5644X052		NPS 6, 8 x 6 or 12 x 6 /	
	NPS 6, 8 x 6 or 12 x 6 /			DN 150, 200 x 150 or 300 x 150	18A2556X072
	DN 150, 200 x 150 or 300 x 150	14A8176X022			

*Recommended spare part.

1. Part included in trim package assembly can be ordered according to the parts kit trim package.
Inconel® is a mark owned by Special Metals Corporation.

Types 1098-EGR and 1098H-EGR

Type EGR Main Valve (Figures 11 and 12) (continued)

Key	Description	Part Number	Key	Description	Part Number
17*	Cage O-ring (continued) Perfluorocarbon (FFKM) NPS 1 / DN 25 NPS 2 / DN 50 NPS 3 / DN 80 NPS 4 / DN 100 NPS 6, 8 x 6 or 12 x 6 / DN 150, 200 x 150 or 300 x 150	10A7777X032 10A7779X132 14A5688X112 10A3481X032 18A2556X062	21*	Travel Indicator Fitting or Indicator Plug O-ring (continued) Ethylenepropylene (EPR) NPS 1 / DN 25 NPS 2, 3 or 4 / DN 50, 80 or 100 NPS 6, 8 x 6 or 12 x 6 / DN 150, 200 x 150 or 300 x 150 Perfluorocarbon (FFKM) NPS 1 / DN 25 NPS 2 / DN 50 NPS 3 / DN 80 NPS 4 / DN 100 NPS 6, 8 x 6 or 12 x 6 / DN 150, 200 x 150 or 300 x 150	10A8931X022 10A3800X042 1F2629X0032 10A8931X032 10A3800X062 10A3800X062 10A3800X062 1F2629X0042
18	Travel Indicator Scale, plastic NPS 1 ⁽¹⁾ / DN 25 NPS 2 ⁽¹⁾ / DN 50 NPS 3 ⁽¹⁾ / DN 80 NPS 4 / DN 100 with 2 in. / 51 mm travel ⁽¹⁾ with 1-1/2 in. / 38 mm travel NPS 6, 8 x 6 or 12 x 6 ⁽¹⁾ / DN 150, 200 x 150 or 300 x 150	14A6759X012 14A5678X012 14A5662X012 14A5647X012 14A5662X012 14A5647X012	22 ⁽¹⁾	Travel Indicator Flange Nut, plated steel	14A5693X012
19	Travel Indicator Protector NPS 1 or 2 ⁽¹⁾ / DN 25 or 50, plastic NPS 3, 4, 6 or 8 x 6 ⁽¹⁾ / DN 80, 100, 150 or 200 x 150, plated steel	24B1301X012 14A6769X012	23 ⁽¹⁾	E-Ring Stainless steel Steel, heat-treated (NACE)	14A8181X012 14A8181X022
20*	Plug O-ring Nitrile (NBR) ⁽¹⁾ (standard) NPS 1 / DN 25 NPS 2 / DN 50 NPS 3 / DN 80 NPS 4 / DN 100 NPS 6, 8 x 6 or 12 x 6 / DN 150, 200 x 150 or 300 x 150 Fluorocarbon (FKM) NPS 1 / DN 25 NPS 2 / DN 50 NPS 3 / DN 80 NPS 4 / DN 100 NPS 6, 8 x 6 or 12 x 6 / DN 150, 200 x 150 or 300 x 150 Ethylenepropylene (EPR) NPS 1 / DN 25 NPS 2 / DN 50 NPS 3 / DN 80 NPS 4 / DN 100 NPS 6, 8 x 6 and 12 x 6 / DN 150, 200 x 150 and 300 x 150 Perfluorocarbon (FFKM) NPS 1 / DN 25 NPS 2 / DN 50 NPS 3 / DN 80 NPS 4 / DN 100 NPS 6, 8 x 6 and 12 x 6 / DN 150, 200 x 150 and 300 x 150	14A6981X012 14A5686X012 1V326906562 14A5688X012 1K879306992 14A8188X012 14A5686X022 1V3269X0042 14A5688X022 1V547606382 14A6981X032 14A5686X052 1V3269X0062 14A5688X082 1K8793X0012 14A6981X072 14A5686X072 1V3269X0082 14A5688X112 1K8793X0022	24	Drive Screw, Stainless steel (2 required)	1A368228982
21*	Travel Indicator Fitting or Indicator Plug O-ring Nitrile (NBR) ⁽¹⁾ NPS 1 / DN 25 NPS 2, 3 or 4 / DN 50, 80 or 100 NPS 6, 8 x 6 or 12 x 6 / DN 150, 200 x 150 or 300 x 150 Fluorocarbon (FKM) NPS 1 / DN 25 NPS 2, 3 or 4 / DN 50, 80 or 100 NPS 6, 8 x 6 or 12 x 6 / DN 150, 200 x 150 or 300 x 150	10A8931X012 10A3800X012 1F262906992 10A0811X012 1R727606382 1F2629X0012	25	Flow Arrow	-----
			26	Body Rating Plate, Stainless steel (not shown)	-----
			27	Indicator Plug Zinc-plated steel NPS 1 / DN 25 NPS 2 / DN 50 NPS 3 / DN 80 NPS 4 / DN 100 316 Stainless steel (NACE) NPS 1 / DN 25 NPS 2 / DN 50 NPS 3 / DN 80 NPS 4 / DN 100 NPS 6, 8 x 6 or 12 x 6 / DN 150, 200 x 150 or 300 x 150	14A6983X012 14A9684X012 14A9684X012 14A9684X012 14A6983X022 14A9684X032 14A9684X032 14A9684X032 14A8178X032
			28	Spring Seat Full capacity trim ⁽¹⁾ Plated steel NPS 1 / DN 25 NPS 2, 3 or 4 / DN 50, 80 or 100 NPS 6 or 8 x 6 / DN 150 or 200 x 150 Heat-treated wrought steel (NACE) NPS 1 / DN 25 NPS 2, 3 or 4 / DN 50, 80 or 100 NPS 6, 8 x 6 or 12 x 6 / DN 150, 200 x 150 or 300 x 150 Restricted capacity trim Stainless steel, heat-treated NPS 2, 3 or 4 / DN 50, 80 or 100 NPS 6 / DN 150	14A6982X012 15A2206X012 14A8177X012 14A6982X022 15A2206X022 14A8177X022 14A9678X012 14A9688X012
			29	Hex Nut Steel (use with Stainless steel body) (not shown) NPS 1 / DN 25 (4 required) NPS 2 / DN 50 (8 required) NPS 3 / DN 80 (8 required) NPS 4 / DN 100 (8 required) NPS 6, 8 x 6 or 12 x 6 / DN 150, 200 x 150 or 300 x 150 (12 required)	1C330635252 1A377235252 1A376035252 1A352035252 1A440935252
			31 ⁽¹⁾	Pipe Plug Plated steel, for all sizes 316 Stainless steel (NACE), For NPS 1, 2, 3 or 4 / DN 25, 50, 80 or 100 For NPS 6, 8 x 6 or 12 x 6 / DN 150, 200 x 150 or 300 x 150	1A767524662 1A767535072 1A767535072

- continued -

Types 1098-EGR and 1098H-EGR

Type EGR Main Valve (Figures 11 and 12) (continued)

Key	Description	Part Number
32	Travel Stop, galvanized plated steel (not used with full capacity trim) NPS 2 / DN 50	
	30% capacity	14A9677X012
	70% capacity	14A9676X012
	NPS 3 / DN 80, 40% capacity	14A9671X012
	NPS 4 / DN 100, 40% capacity	14A9670X012
	NPS 6 / DN 150, 40% capacity	14A9682X012
33	NACE Tag (not shown) (NACE)	19A6034X012
34	Tag Wire (not shown) (NACE)	1U7581X0022
35	Fitting	
	All sizes	T21104T0012
	All sizes (NACE)	T21104T0022
36*(1)	Backup Ring (2 Required)	
	All sizes	1K786806992
37*	O-ring	
	Nitrile (NBR) ⁽¹⁾	18B3438X012
	Fluorocarbon (FKM)	1N430306382
	Ethylenepropylene (EPR)	1N4303X0012
	Perfluorocarbon (FFKM)	1N4303X0032
38	Pipe Plug	
	Plated steel	1A767524662
	Stainless steel (NACE)	1A767535072

Key	Description	Part Number
3	Bonnet	
	Zinc-plated steel	33B0301X012
	Stainless steel (NACE)	33B0301X052
4	Cap Screw	
	Sizes 30 and 40 (4 required)	
	Plated Steel	1D529824052
	Stainless steel (NACE)	1D529838992
	Size 70 (4 required)	
	Plated Steel	1A368424052
	Stainless steel (NACE)	1A368435072
5	Casing O-ring	
	Nitrile (NBR)	1F358106992
	Fluorocarbon (FKM)	1F3581X0022
	Ethylenepropylene (EPDM)	1F3581X0052
6	Stem O-ring (2 required)	
	Nitrile (NBR)	1C782206992
	Fluorocarbon (FKM)	1K756106382
	Ethylenepropylene (EPDM)	1C7822X0052
7	Diaphragm	
	Type 1098	
	Nitrile (NBR)	
	Size 30	2E791902202
	Size 40	27B9744X012
	Size 70	2N126902202
	Fluorocarbon (FKM)	
	Size 30	2E7919X0052
	Size 40	27B9744X022
	Size 70	2N1269X0032
	Ethylenepropylene (EPDM)	
	Size 30	2E7919X0062
	Size 40	27B9744X032
	Size 70	2N1269X0042
	Type 1098H, Size 30	
	Nitrile (NBR)	2E791902202
	Fluorocarbon (FKM)	2E7919X0052
	Ethylenepropylene (EPDM)	2E7919X0062

Types 1098 and 1098H Actuators (Figure 13)

Key	Description	Part Number
1	Lower Casing	
	Size 30	
	Type 1098	
	Steel	2E8007X00B2
	Steel (NACE)	2E8007X0042
	Type 1098H	
	WCC Steel	36A8537X012
	CF8M Stainless steel (NACE)	36A8537X032
	Size 40	
	Type 1098	
	Steel	24A7155X012
	Steel (NACE)	24A7155X072
	Stainless steel (NACE)	24A7155X052
	Size 70	
	Type 1098	
	Steel	2N1266X00B2
	Steel (NACE)	2N1266X0072
	Stainless steel (NACE)	2N1266X0082
2	Upper Casing	
	Size 30	
	Type 1098	
	Steel	25A7340X012
	Steel (NACE)	25A7340X032
	Type 1098H	
	WCC Steel	36A8535X012
	Stainless steel (NACE)	36A8535X052
	Size 40	
	Type 1098	
	Steel	24A5680X012
	Steel (NACE)	24A5680X062
	Stainless steel (NACE)	24A5680X042
	Size 70	
	Type 1098	
	Steel	25A2607X012
	Steel (NACE)	25A2607X032
	Stainless steel (NACE)	25A2607X042

Key	Description	Part Number
8	Diaphragm Plate	
	Size 30	
	Cast Iron	15A7339X012
	316 Stainless steel (NACE)	GE08313X012
	Size 40	
	Cast Iron	14A5682X012
	316 Stainless steel (NACE)	GE08466X012
	Size 70	
	Cast Iron	15A2606X012
	316 Stainless steel (NACE)	37B9057X022
9	Cap Screw	
	Sizes 30 and 40	
	Steel	1L545428982
	Stainless steel (NACE)	1L545438992
	Size 70	
	Steel	11B1768X012
	Steel (NACE)	11B1768X022
	Stainless steel (NACE)	11B1768X032
10	Cap Screw	
	Size 30 (12 required)	
	Cap Screw, Plated steel	
	Type 1098 (NACE)	1E760324052
	Type 1098H	1A915524052
	Stud, Stainless steel	
	Type 1098H (NACE)	1A219235222
	Size 40 (16 required)	
	Cap Screw, Type 1098 (NACE)	
	Plated steel	1E760324052
	Stainless steel	1E7603X0072
	Size 70 (28 required)	
	Type 1098 (NACE)	
	Steel	1A582824052
	Stainless steel	1A5828X0122

*Recommended spare part.

1. Part included in trim package assembly can be ordered according to the parts kit trim package.

- continued -

Types 1098-EGR and 1098H-EGR

Types 1098 and 1098H Actuators (Figure 13) (continued)

Key	Description	Part Number
11	Hex Nut Type 1098 Size 30 (12 required) Plated steel (NACE)	1A346524122
	Size 40 (16 required) Plated steel (NACE)	1A346524122
	Stainless steel (NACE)	1A3465X0032
	Size 70 (28 required) Plated steel (NACE)	1A346524122
	Stainless steel (NACE)	1A3465X0102
	Type 1098H Size 30 (12 required) Plated steel	1A340324122
	Stainless steel (NACE)	1A337435252
12	Stem, Stainless steel NPS 1 / DN 25 body size	14A6757X012
	NPS 1 / DN 25 body size (NACE)	14A6757X022
	NPS 2 / DN 50 body size	14A5683X012
	NPS 2 / DN 50 body size (NACE)	14A5683X022
	NPS 3 / DN 80 body size	14A5663X012
	NPS 3 / DN 80 body size (NACE)	14A5663X022
	NPS 4 / DN 100 body size	14A5648X012
	NPS 4 / DN 100 body size (NACE)	14A5648X022
	NPS 6 / DN 150 body size	14A6987X012
	NPS 6 / DN 150 body size (NACE)	14A6987X022
	NPS 8 x 6 / DN 200 x 150 body size (NACE)	18A4217X022
	NPS 12 x 6 / DN 300 X 150 body size (NACE)	17B6060X012
13	Nameplate	-----
27	Vent Insert	Type Y602-12
28	Zerk Fitting, plated carbon steel	1L847828992
54	NACE Tag, Stainless steel (not shown)	19A6034X012
55	Tag Wire, Stainless steel (not shown)	1U7581X0022
56	Bearing (2 required) For Nitrile (NBR) Diaphragm, Nylon (PA)	17A7112X012
	For Fluorocarbon (FKM) and Ethylene propylene (EPDM) Diaphragms, Nyliner	17A7112X022
57	Wiper	15A6002XN12

Standard P590 Series Filter (Figure 14)

Key	Description	Part Number
1	Filter Body Type P594-1, Brass	1E312414012
	Type P593-1, Aluminum (NACE)	1E3124X0022
2*	Filter Element, Cellulose (NACE)	1E312606992
3	Filter Head Type P594-1, Brass	1E312514012
	Type P593-1, Aluminum (NACE)	1E3125X0022
4	Machine Screw Type P594-1, Brass	1J500218992
	Type P593-1, Aluminum (NACE)	1J500209012
5	Washer (2 required) Type P594-1, Brass	1J500018992
	Type P593-1, Aluminum (NACE)	1J500010062
6	Spring Washer, Plated carbon steel	1H885128982
7*	Gasket, composition	1F826804022
11	NACE Tag, Stainless steel (not shown)	19A6034X012
12	Tag Wire, Stainless steel (not shown)	1U7581X0022

Type 6351 Pilot (Figure 15)

Key	Description	Part Number
	Parts Kit (includes keys 3, 4, 6, 7, 23 and for the P590 Series filter, keys 2 and 7)	R6351X00012
1	Body Assembly Aluminum with Brass bushing	1B7971X0092
	Aluminum with Stainless steel bushing (NACE)	1B7971X0342
	Stainless steel with Stainless steel bushing	1B7971X0122
2	Bonnet Aluminum with closing cap	25A6220X012
3	Body Plug Assembly (includes body plug and O-ring) Aluminum body plug with Nitrile (NBR) O-ring	18B6542X022
	with Fluorocarbon (FKM) O-ring	18B6542X042
	with Ethylene propylene (EPDM) O-ring	18B6542X082
	Stainless steel body plug with Nitrile (NBR) O-ring	18B6542X052
	with Fluorocarbon (FKM) O-ring	18B6542X062
4	Inner Valve Assembly Nitrile (NBR) with Brass stem	20B9389X012
	Nitrile (NBR) with Stainless steel stem (NACE)	20B9389X022
	Fluorocarbon (FKM) with Stainless steel stem	20B9389X042
	Fluorocarbon (FKM) with Brass stem	20B9389X032
	Ethylene propylene (EPDM) with Stainless steel stem	20B9389X172
6	Valve Spring For Brass and Stainless steel stems, Stainless steel	1B797937022
	For Stainless steel stem (NACE), Inconel® X-750	19A2860X012
7*	Diaphragm Assembly (includes plated steel diaphragm plate) Nitrile (NBR) diaphragm and Aluminum pusher post	1B7980000B2
	Nitrile (NBR) diaphragm and Stainless steel pusher post	1B7980X00A2
	Fluorocarbon (FKM) diaphragm and Aluminum pusher post	1B7980000C2
	Ethylene propylene (EPDM) diaphragm and Stainless steel pusher post	1B7980X0232
8	Upper Spring Seat	1B798525062
9	Control Spring, plated steel 3 to 20 psig / 0.21 to 1.4 bar range, Green	1B986027212
	5 to 35 psig / 0.35 to 2.4 bar range, Unpainted	1B788327022
	35 to 100 psig / 2.4 to 6.9 bar range, Red	1K748527202
10	Adjusting Screw Aluminum bonnet	10B7192X012
11	Locknut, plated steel Aluminum bonnet	1A946324122
12	Machine Screw, Steel (6 required)	T13305T0012
13	Hex Lock Plate, Aluminum (not shown)	10B2695X012
14	Threaded Lock Plate, Sluminum (not shown)	10B2696X012
22	Pipe Nipple, Standard and Corrosive service, Galvanized plated steel (use with P590 Series) Steel (NACE)	1C488226232
		1C4882X0032
24	P590 Series Filter (parts listed under separate heading) Type P594-1, Brass (standard)	AJ5004000A2
	Type P593-1, Aluminum	AJ5004T0012
28	Closing Cap, Plastic Aluminum bonnet	23B9152X012
35	Vent Assembly (Type Y602-12)	Y602-12
42	Check Valve Assembly Aluminum / Stainless steel (NACE)	16A5929X042
	All other assemblies	16A5929X022

Types 1098-EGR and 1098H-EGR

Types 6352, 6353, 6354L, 6354M and 6354H Pilots (Figure 16)

Key	Description	Part Number
	Parts kit (included are: valve plug, key 4; diaphragm assembly, key 5; body plug gasket, key 12; bellows O-ring, key 17; closing cap gasket, key 20; and for the P590 Series filter, filter element, key 2; and gasket, key 7)	
	Type 6352	R6352X00012
	Type 6353	R6353X00012
	Type 6354	R6354X00012
1	Pilot Body	
	Aluminum with 25 psig / 1.7 bar check valve	35A6228X012
	Aluminum with 50 psig / 3.4 bar, Type 1806H check valve	17A8075X012
	Stainless steel with 25 psig / 1.7 bar, check valve	39A5971X012
	Stainless steel with 50 psig / 3.4 bar, Type 1806H check valve	17A8075X022
2	Spring Case	
	Aluminum	25A6220X012
	Stainless steel	28A9277X012
2	Regulator Bonnet (for Type 6353)	24B6641X022
3	Body Plug	
	Aluminum	15A6221X012
	316 Stainless steel	15A6221X042
4	Valve Plug and Stem Assembly	
	Nitrile (NBR) disk with Stainless steel stem (standard)	15A6207X012
	Nitrile (NBR) disk with Stainless steel stem (NACE)	15A6207X052
	Fluorocarbon (FKM) with Stainless steel stem (for use in Oxygen service)	15A6207X042
	Fluorocarbon (FKM) disk with Stainless steel stem (NACE)	15A6207X112
5	Diaphragm Assembly	
	Type 6352	
	Nitrile (NBR)	15A6216X012
	Nitrile (NBR) (NACE)	15A6216X552
	Fluorocarbon (FKM)	15A6216X082
	Fluorocarbon (FKM) (NACE)	15A6216X662
	Ethylene propylene (EPDM)	15A6216X522
	Ethylene propylene (EPDM) (NACE)	15A6216X682
	Type 6353	
	Nitrile (NBR)	15A6216X022
	Nitrile (NBR) (NACE)	15A6216X542
	Fluorocarbon (FKM)	15A6216X092
	Fluorocarbon (FKM) (NACE)	15A6216X562
	Ethylene propylene (EPDM)	15A6216X392
	Ethylene propylene (EPDM) (NACE)	15A6216X692
	Type 6354	
	Neoprene (CR)	15A6216X032
	Neoprene (CR) (NACE)	15A6216X572
	Fluorocarbon (FKM)	15A6216X152
	Fluorocarbon (FKM) (NACE)	15A6216X582
	Ethylene propylene (EPDM)	15A6216X512
	Ethylene propylene (EPDM) (NACE)	15A6216X702
6	Control Spring	
	Type 6352	
	14 in. w.c. to 2 psig / 35 mbar to 0.14 bar, Yellow	14A9672X012
	2 to 10 psig / 0.14 to 0.69 bar, Black	14A9673X012
	Type 6353	
	3 to 40 psig / 0.21 to 2.8 bar, Yellow	1E392527022
	35 to 125 psig / 2.4 to 8.6 bar, Red	1K748527202
	Type 6354L	
	85 to 200 psig / 5.9 to 13.8 bar, Blue	1L346127142
	Type 6354M	
	175 to 220 psig / 12.1 to 15.2 bar, Blue	1L346127142
	Type 6354H	
	200 to 300 psig / 13.8 to 20.7 bar, Green	15A9258X012

Key	Description	Part Number
7	Spring Seat, Plated steel Type 6352 or 6353 Type 6354L, 6354M or 6354H	1B798525062 1K155828982
8	Stem Guide 416 Stainless steel (standard) 410 Stainless steel (NACE)	15A6222X012 15A6222X022
9	Adjusting Screw Type 6352 Type 6353 Type 6354	10B3692X012 10B7192X012 10B6190X012
10	Locknut Type 6352 Type 6353 or 6354	1C724018992 1A946324122
11	Closing Cap Aluminum Stainless steel	23B9152X012 1H2369X0032
12	Body Plug Gasket / O-ring For Aluminum body, composition For Stainless steel body, Nitrile (NBR) For Stainless steel body, Fluorocarbon (FKM) For Stainless steel body, Ethylene propylene (EPDM)	1C495704022 1F113906992 1N463906382 1F1139X0052
13	Vent Assembly Type Y602-12	10B6189X022
14	Machine Screw (6 required) Aluminum Stainless steel, NACE	1V4360X0112
15	Check Valve Assembly 25 psig / 1.7 bar 25 psig / 1.7 bar (NACE) 25 psig / 1.7 bar (for Oxygen service) 25 psig / 1.7 bar (Stainless steel)	16A5929X052 16A5929X042 16A5929X032 16A5929X072
16	Bellows Assembly, Stainless steel Standard for all except in Oxygen service For use in Oxygen service	15A6202X032 15A6202X022
17	O-ring Nitrile (NBR), Standard and NACE Service Fluorocarbon (FKM), Standard and NACE Service (also for Oxygen service) Ethylene propylene (EPDM)	1D682506992 1D6825X0012 1D6825X0042
19	Filter P590 Series (standard), (Type P594-1) P590 Series for corrosive service, (Type P593-1)	----- -----
20	Closing Cap Gasket, Composition	15A6218X012
21	Pipe Nipple For standard and corrosive service, Galvanized steel For NACE service, Steel For corrosive NACE service, Stainless steel	1C488226232 1C4882X0032 1C488238982
22	Restriction, Plated Carbon Steel Standard High	17A2030X012 17A2029X012
23	Diaphragm Limiter Aluminum Stainless steel	15A9259X012 10B4407X012
26	NACE Tag, Stainless steel	19A6034X012
27	Tag Wire, Stainless steel	1U7581X0022
28	Packing Bonnet, 316 Stainless steel	1L449635072
29	Packing Nut, Plated Steel	0P077624102
30	Handwheel	1L217544992
31	Washer, Plated Carbon steel	1A329128982
32	Screw, Plated Carbon steel	1E985428982
33	Packing Spring, 316 Stainless steel	1F125437012
34	Packing Box Gasket, Plated steel	ERAA01635A0
35	Packing Follower, 316 Stainless steel	1K885035072
36	External Adaptor, PTFE	1F124801012
37	Internal Adaptor, PTFE	1F124401012
38	Packing Washer, 316 Stainless steel	1F125236042
39	Packing Ring (3 required), PTFE	1C752601012
40	Adjusting Screw, Stainless steel	21B5621X012

Types 1098-EGR and 1098H-EGR

61 Series Pilots (Figures 17, 18 and 19)

Key	Description	Part Number	Key	Description	Part Number
	Repair Parts Kits, Nitrile (NBR) (Includes keys 8, 9, 10, 12, 13, 14, 15, 26 and 28) Types 61L and 61LE	R61LX000012	9	Disk Holder Assembly (for 61 Series except Type 61HP)	
	Types 61LD	R61LDX000012		Standard trim, Brass / Nitrile (NBR)	1B8868000A2
	Repair Parts Kits, Nitrile (NBR) (Includes keys 8, 9, 10, 12, 13, 14, 15 and 26) Type 61H	R61HX000012		Trim for corrosive service, Stainless steel	1B8868000B2
1	Relay Spring Case, Cast Iron			Oxygen service and pressure loaded trim for corrosive service, Brass / Fluorocarbon (FKM)	1N3638000A2
	Types 61L, 61LD and 61LE	1B983919012	10	Bleed Orifice, Stainless steel	
	Type 61H			Types 61L, 61LD, 61LE and 61H	
	Standard adjusting screw	1B984119012		Standard bleed	1B887335032
	Capped adjusting screw	1H232619012		Special bleed	1C831435032
	Type 61HP			Capped bleed (for Types 61L and 61LD only)	1D777135032
2	Relay Valve Body, Cast Iron			Type 61HP	1D318135032
	Types 61L, 61LD, 61LE and 61H	2J581919012	11	Diaphragm Nut, (for 61 Series except Type 61HP)	
	Type 61HP	33A9845X012		Standard trim, Oxygen service and pressure loaded trim for corrosive service, 316 Stainless steel	1B989514012
3	Bottom Cover			Trim for corrosive service, Stainless steel	1B989535072
	Types 61L, 61LD, 61LE and 61H, Cast Iron	2C518619012	12*	O-ring Seal (for 61 Series except Type 61HP)	
	Type 61HP, Steel	13A9843X012		Standard and trim for corrosive service, Nitrile (NBR)	1B885506992
4	Relay Yoke			Oxygen service and pressure loaded trim for corrosive service, Fluorocarbon (FKM)	1B8855X0012
	Types 61L, 61LD, 61LE and 61H, Zinc Die Casting	1D662544012	13	Relay Spring, Stainless steel	
	Type 61HP (2 required), Stainless steel	13A9838X012		Types 61L and 61LE	1C911537022
5	Closing Cap Assembly			Type 61LD	1E643637022
	Types 61L, 61LD and 61LE			Type 61H	
	For all except pilots with handwheel adjusting screw and pressure loaded pilots, Plastic	T11069X0012		Up to 300 psig / 20.7 bar inlet pressure	1C911537022
	Pressure loaded trim for corrosive service, Steel	1E422724092		300 to 400 psig / 20.7 to 27.6 bar inlet pressure	1N859137022
	Standard trim with handwheel adjusting screw, Brass	1R759314012		Type 61HP	1B797937022
	Type 61H, Capped adjusting screw, Brass	1H236514012	14*	Upper Relay Diaphragm	
6	Adjusting Screw			Types 61L, 61LD, 61LE and 61H	
	Types 61L, 61LD and 61LE			Standard and trim for corrosive service, Nitrile (NBR)	1B885202052
	For all except handwheel adjusting screw, Zinc Die Casting	1B537944012		Oxygen service and pressure loaded trim for corrosive service, Fluorocarbon (FKM)	1N162802332
	For use with handwheel adjusting screw, Brass	1R759414012		Type 61HP	
	Type 61H, Steel			Standard, Neoprene (CR)	13A9841X022
	Standard			Oxygen service, Fluorocarbon (FKM)	13A9841X012
	For 10 to 35 psig / 0.69 to 2.4 bar range	1A500528982	15*	Lower Relay Diaphragm	
	For 10 to 50 psig / 0.69 to 3.5 bar range	1B212028982		Types 61L, 61LD and 61LE	
	For 10 to 65 psig / 0.69 to 4.5 bar range	1A279128982		Standard and trim for corrosive service, Nitrile (NBR)	1B886002052
	Pressure loaded/capped adjusting screw	1J881524102		Oxygen service and pressure loaded trim for corrosive service, Fluorocarbon (FKM)	1N536102332
	Type 61HP, Steel			Type 61H	
	Standard	1C216032992		Standard and trim for corrosive service, Neoprene (CR)	1B894202192
7	Control Spring, Steel			Oxygen service, Fluorocarbon (FKM) (2 required)	1N162702302
	Type 61LD			Type 61HP	
	0 to 4 in. w.c. / 0 to 10 mbar, Orange	ERAA11768A0		Standard, Neoprene (CR)	13A9840X012
	3 to 12 in. w.c. / 7 to 30 mbar, Unpainted	1C680627222		Oxygen service, Fluorocarbon (FKM)	13A9840X022
	Types 61L, 61LD and 61LE		16	Upper Relay Head, Zinc-plated steel	
	0.25 to 2 psig / 17 mbar to 0.14 bar, Red	1B886327022		Types 61L and 61LD	1B989325072
	1 to 5 psig / 69 mbar to 0.35 bar, Yellow	1J857827022		Type 61LE	1D558425072
	2 to 10 psig / 0.14 to 0.69 bar, Blue	1B886427022		Type 61H	1D558425072
	5 to 15 psig / 0.34 to 1.0 bar, Brown	1J857927142	16	Diaphragm Plate, Stainless steel	
	10 to 20 psig / 0.69 to 1.4 bar, Green	1B886527022		Type 61HP (4 required)	13A9839X012
	Type 61H		17	Lower Relay Head, Zinc-plated steel	
	10 to 65 psig / 0.69 to 4.5 bar, Green Stripe	0Y066427022		Types 61L, 61LD and 61LE	1B989425072
	Type 61HP			Type 61H	1D558325072
	15 to 45 psig / 1.0 to 3.1 bar, Yellow	1E392527022	18	Spring Seat, Zinc-plated steel	
	35 to 100 psig / 2.4 to 6.9 bar, Blue	1D387227022		Types 61L, 61LD and 61LE	1B886225072
	100 to 300 psig / 6.9 to 20.7 bar, Red	1D465127142		Type 61H	1D558525072
8	Relay Orifice (for 61 Series except Type 61HP), Stainless steel		19	Hex Nut, Zinc-plated steel	
	Standard applications	1C520135032		Types 61L, 61LD, 61LE and 61H	1A340324122
	Fast close and open, open only or close only (For Types 61L, 61LD and 61H only)	1D373735032		Type 61HP (2 required)	1A346524122
	Special orifice, fast open only application (For Types 61L and 61LD only)	1E874235132	20	Cap Screw (8 required), Zinc-plated steel (For 61 Series except Type 61HP)	1B989624052

- continued -

*Recommended spare part.

Types 1098-EGR and 1098H-EGR

61 Series Pilots (Figures 17, 18 and 19) (continued)

Key	Description	Part Number
23	Pipe Plug or Vent Assembly Pipe Plug for Types 61L, 61LD and 61LE, Steel Vent Assembly for Type 61H	1A649528982 Type Y602-1
24	Pipe Nipple, Galvanized / Zinc-plated steel	1C488226232
25	Filter Assembly Standard trim Trim for corrosive service	Type P594-1 Type P593-1
26	Bleed Valve Types 61L, 61LE and 61H, Stainless steel Type 61LD, Stainless steel Type 61HP Standard Trim, Stainless steel / Nitrile (NBR) Oxygen Service, Stainless steel / Fluorocarbon (FKM)	1D986735132 1H951635132 1D5604000B2 1N3798000C2
27	Nameplate	-----
28*	Gasket Types 61L, 61LD and 61LE, Neoprene (CR) Type 61H, PTFE	1P753306992 ERAA01635A0
30	Pipe Plug (for 61 Series except Type 61HP), (2 required) Zinc-plated steel	1A369224492
32	Bleed Orifice Cap (for Types 61L and 61LD with capped bleed only), Stainless steel	1D777235032
33	Handwheel (for Types 61L, 61LD and 61LE only), Zinc Die Cast	1J496144012
34	Hex Nut Types 61L, 61LD and 61LE Type 61H Type 61HP	1A351124122 1A352424122 1A352224122
35	Spring Seat, Zinc-plated steel Types 61L, 61LD and 61LE Type 61H Type 61HP	1J618124092 16A9812X012 10A3963X012
40*	O-ring (for Types 61L, 61LD and 61LE only), Nitrile (NBR)	1D541506992
41	Adaptor (for Type 61H only), Brass	1J881624092
42	Yoke Cap (for Type 61HP only), Stainless steel	13A9836X012
43	Lockwasher (for Types 61L, 61LD and 61LE), Steel	1A352332992
44	Machine Screw (for Types 61L, 61LD and 61LE only), Steel	16A5763X012
45	Valve Spring Seat (for Type 61HP only), 316 Stainless steel	1L251135072
46	Cap Screw (6 required) (for Type 61HP only)	15A0690X012
47	Machine Screw (4 required) (for Type 61HP only), Stainless steel	1A866935032
48	Cap Screw (6 required) (for Type 61HP only)	1P327028982
50	Drive Screw (2 required), Stainless steel	1A368228982
51*	Diaphragm Insert (2 required) (for Type 61HP only) Standard, Nitrile (NBR) Oxygen service, Fluorocarbon (FKM)	13A9842X012 13A9842X022
52	Lower Yoke Cap (for Type 61HP only), 410/416 Stainless steel	13A9837X012
53	Bleed Plug (for Type 61HP only), Brass	1V211514012

Type Y600AM Parts List (Figures 20 and 21)

Key	Description	Part Number
	Parts Kit (keys 10, 11, 12, 13, 15, 30, 31 and 33) Type Y600AM	RY600AX0012
1	Body, Cast Iron 3/4 NPT	1E987119012
2	Cap Screw (2 required), Zinc-plated steel	1C856228992
3	Spring Case Assembly, Cast iron	1B6365X0342
4	Diaphragm Casing, Cast iron	47B2271X012
5	Orifice, Aluminum, 1/4 in. / 6.4 mm	0B042009012
6	Spring, Plated steel 4 to 8 in. w.c. / 10 to 20 mbar, Red 7 to 16 in. w.c. / 17 to 40 mbar, Unpainted 15 in. w.c. to 1.2 psig / 37 mbar to 0.08 bar, Yellow 1.2 to 2.5 psig / 0.08 to 0.17 bar, Green 2.5 to 4.5 psig / 0.17 to 0.31 bar, Light Blue 4.5 to 7 psig / 0.31 to 0.52 bar, Black	1B653827052 1B653927022 1B537027052 1B537127022 1B537227022 1B537327052
7	Diaphragm Head, 304 Stainless steel	17B9723X032
8	Pusher Post, Aluminum	17B9734X032
10*	Diaphragm, Nitrile (NBR)	17B9726X012
11*	Body Seal O-ring, Nitrile (NBR)	1H993806992
12*	Insert Seal O-ring, Nitrile (NBR)	1B885506992
13*	Disk Assembly, Aluminum Disk Holder with Nitrile (NBR) disk	1C4248X0212
14	Stem, Stainless steel	17B3423X012
15*	Cotter Pin, Stainless steel	1A866537022
16	Lever Assembly, Steel / Stainless steel	1B5375X0082
17	Machine Screw (2 required), Stainless steel	19A7151X022
18	Guide Insert, Delrin®	27B4028X012
22	Closing Cap	T11069X0012
23	Hex Nut, not shown (8 required), Zinc-plated steel	1E985324142
24	Cap Screw (8 required), Zinc-plated steel	T1070824912
25*	Closing Cap Gasket, Neoprene (CR)	1P753306992
26	Type Y602 Vent Assembly Spring case up (standard) Spring case down	Type Y602-11 Type Y602-1
30*	Stem O-ring Nitrile (NBR)	1H292606992
31*	Throat Seal O-ring Nitrile (NBR)	1D682506992
33	Machine Screw, Stainless steel	18A0703X022
35	Adjusting Screw, Zinc	1B537944012
36	Washer, Plated Carbon Steel	18B3440X012
38	Diaphragm Cap Screw, Zinc-plated steel	1B290524052
48	Backup Ring, Stainless steel	18B3446X012
50	Lower Spring Seat, Zinc-plated steel	1B636325062
51	Nameplate	-----
52	Drive Screw (2 required)	1A368228982

*Recommended spare part.
Delrin® is a mark owned by E.I. du Pont de Nemours and Co.

Types 1098-EGR and 1098H-EGR

Type MR95H Regulator (Figure 22)

Key	Description	Part Number
	Parts Kit (Included are keys 3, 4, 12 and 63) for Neoprene (CR) diaphragm, Nitrile (NBR) / 416 Stainless steel disk, 1/4 NPT body	RMR95HX0032
1	Body, 1/4 NPT, Cast iron	ERCA01628A0
2	Spring Case, Cast iron	ERCA03544A0
3*	Orifice, 416 Stainless steel	GF05038X022
4*	Valve Plug, 416 Stainless steel Nitrile (NBR)	ERCA00634A4
5	Valve Plug Guide, 416 Stainless steel	GF05490X022
6	Stem Assembly, 416 Stainless steel	ERCA00638A0
7*	Stem Guide Bushing, 416 Stainless steel	ERCA03695A0
8	Lower Spring Seat Aluminum (standard)	1E392309012
9	Upper Spring Seat, Zinc-plated steel	ERCA00383A0
11	Spring, Zinc-plated steel, Yellow	1E392527022
12*	Diaphragm, Neoprene (CR)	ERCA00672A0
13	Nameplate (not shown)	-----
15	Adjusting Screw, Plated Carbon steel	GF05533X012
16	Cap Screw (6 required), Zinc-plated steel	ERCA04149A0
17	Locknut, Zinc-plated steel	ERCA00652A0
20	Pitot Tube, Stainless Steel	ERCA04393A1
26	Valve Plug Spring, Stainless Steel	ERCA04280A0
63	Bottom Plug Seal, Nitrile (NBR)	ERCA03017A0

Mounting Parts

6350 Series Mounting Parts (Figure 23)

Key	Description	Part Number
16	Pipe Tee for use with 50 psig / 3.4 bar check valve	1C597547362
21	Tube Fitting Connector for use with 50 psig / 3.4 bar check valve, steel	-----
23	Pipe Nipple Type 1098 Actuator Sizes 30 and 40 Plated steel	1C210026232
	Stainless steel (NACE) For use with 50 psig / 3.4 bar check valve Actuator Size 70	1C2100X0012
	Plated steel	19A7858X012
	Stainless steel (NACE)	19A7858X032
	Type 1098H Steel	1C488226232
	Stainless steel	1C488238982
24	Tubing	-----
25	Tube Fitting Elbow (3 required, check valve mounting)	-----
26	Pipe Bushing Steel (NACE)	1C379026232
	Stainless steel (NACE)	1C3790X0012
51	Pipe Nipple, for use with 50 psig / 3.4 bar check valve (2 required) (not shown)	1C488226232
52	Pipe Tee, for use with 50 psig / 3.4 bar check valve (not shown)	1A473621992

*Recommended spare part.

61 Series Mounting Parts (Figure 24)

Key	Description	Part Number
14	Pipe Nipple For standard 61 Series mounting Actuator Sizes 30 and 40 Steel	1F731526012
	Stainless steel	1F7315X0012
	Actuator Size 70 Steel	15A1810X012
	Stainless steel	15A1810X022
	Negative shock service Actuator Sizes 30 and 40	1C782526012
	Actuator Size 70	1F731526012
15	Pipe Nipple Actuator Sizes 30 and 40 Steel	1F730226012
	Stainless steel	GE15728X012
	Actuator Size 70 Steel	15A2610X012
	Stainless steel	15A2610X022
	Negative shock service Actuator Sizes 30 and 40	1F730226012
	Actuator Size 70	15A2610X012
16	Pipe Tee Steel	1A473621992
	Stainless steel	1H3594X0022
18	Check Valve Tubing	-----
19	Tube Fitting Tee	-----
20	Loading Tubing	-----
21	Tube Fitting Connector	-----
22	Tube Fitting Elbow	-----
26	Pipe Bushing for size 70 actuator only Steel	1C379026232
	Stainless steel	1C3790X0012
39	Pipe Nipple for negative shock service only	1A4735X0012
53	Pipe Elbow for negative shock service only	1B952821992

Auxiliary Pilot Mounting Parts (Figure 25)

Key	Description	Part Number
22	Tube Elbow	-----
24	Tubing	-----
30	Mounting Bracket	1H3504X0012
31	Cap Screw (2 required)	1A582824052
32	Cap Screw (2 required) For Type 627-109 For Type 161AYW	1A579724052 1A553424052
35	Tube Connector (1 required for use with Type 6353 pilot and 2 required with Type 61H Pilot)	-----
36	Pipe Bushing, Hex (2 required)	1A3424X00A2

Type 1098-EGR with Type Y600AM Mounting Parts (Figure 26)

Key	Description	Part Number
16	Pipe Tee	-----
22	Tubing Elbow (4 required)	-----
24	Tubing	-----
30	Mounting Bracket, steel	24B0203X012
31	Cap Screw, Zinc-plated steel (2 required)	1A582824052
32	Cap Screw, Zinc-plated steel (2 required)	1C856228992
35	Tubing Connector (4 required)	-----
36	Pipe Bushing (3 required), Stainless steel	1A3424X0022
38	Pipe Nipple (3 required), 316 Stainless steel	15A4786X012
39	Pipe Nipple (3 required), 316 Stainless steel	1C488238982
43	Pipe Bushing (5 required), 316 Stainless steel	1C3790X0012
44	Pipe Bushing, 316 Stainless steel	1K2895X0012

- continued -

Types 1098-EGR and 1098H-EGR

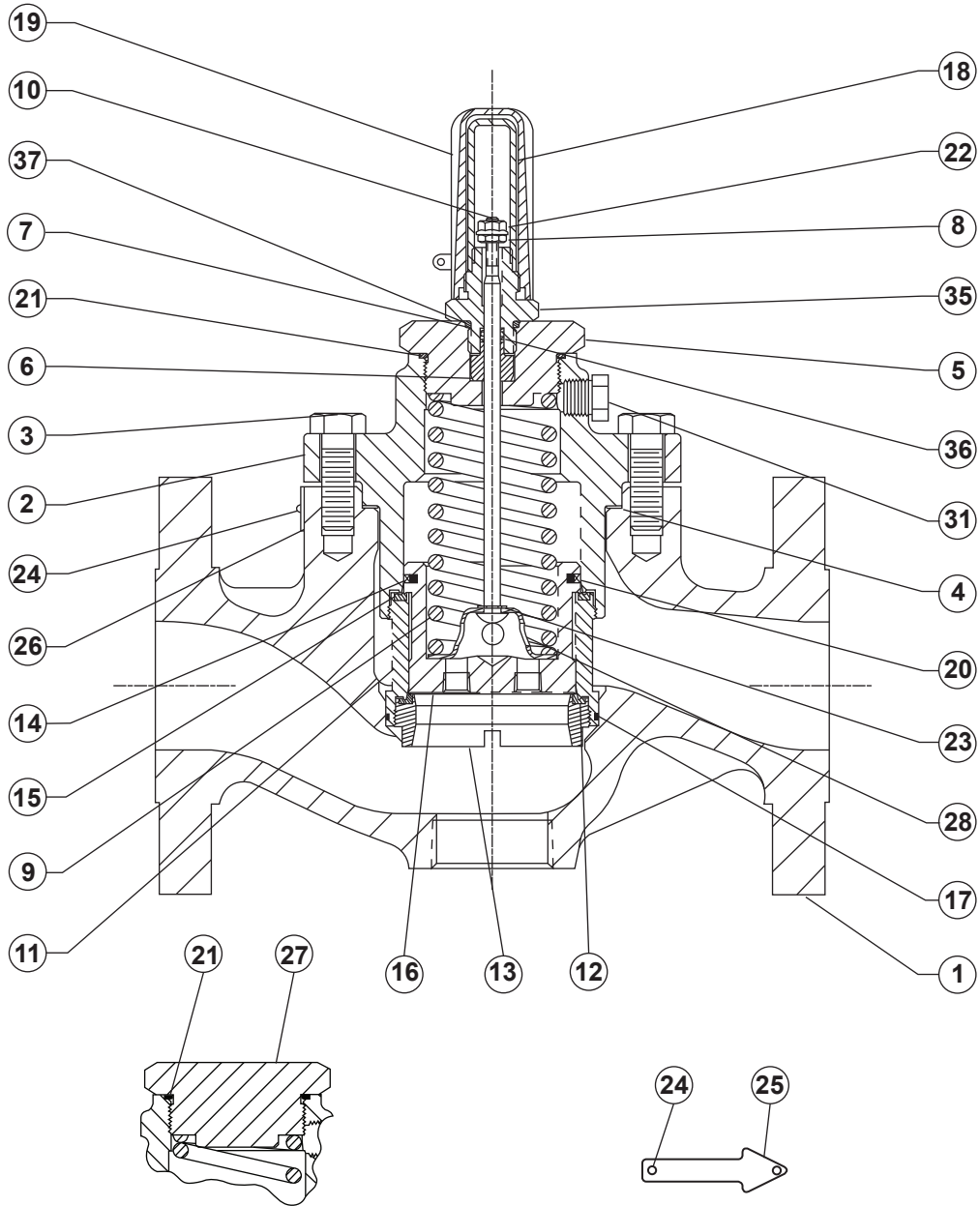

INDICATOR PLUG ASSEMBLY

COMPLETE CAST IRON
FULL-CAPACITY MAIN VALVE ASSEMBLY

Figure 11. Type EGR Main Valve Construction

Mounting Parts (continued)

Type 1098-EGR with Type Y600AM Mounting Parts (Figure 26) (continued)

Key	Description	Part Number	Key	Description	Part Number
50	Pipe Cross, 316 Stainless steel	1C6790X0012	52	Pipe Plug (2 required), 316 Stainless steel	1A767535072
51	Restrictor		53	Pipe Tee, 316 Stainless steel	-----
	Fixed Restriction, Stainless steel	1K9484X0022			
	Variable Restriction (Optional)	Type 112			

35A3167

Types 1098-EGR and 1098H-EGR

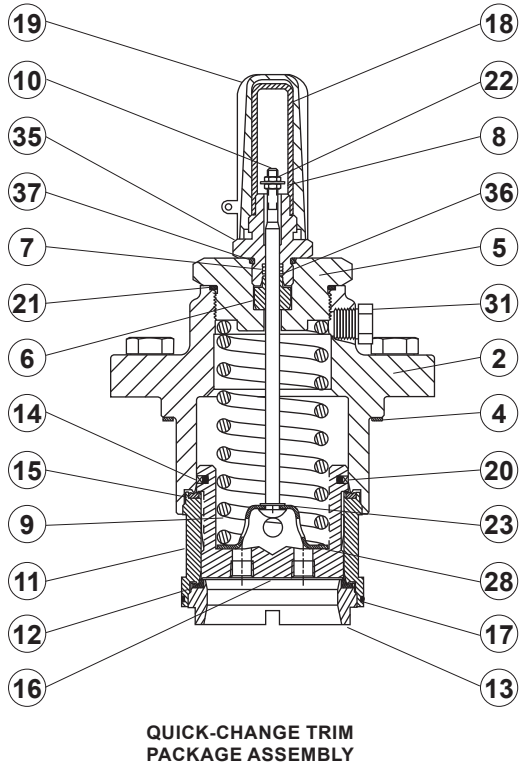

25A3170

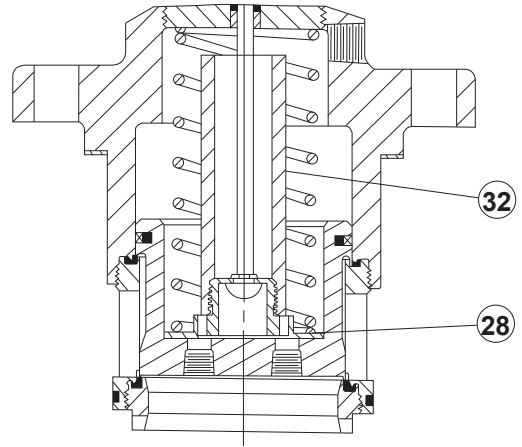

DETAIL OF OPTIONAL RESTRICTED CAPACITY CONSTRUCTION

26A3800

Figure 12. Type EGR Main Valve Internal Constructions

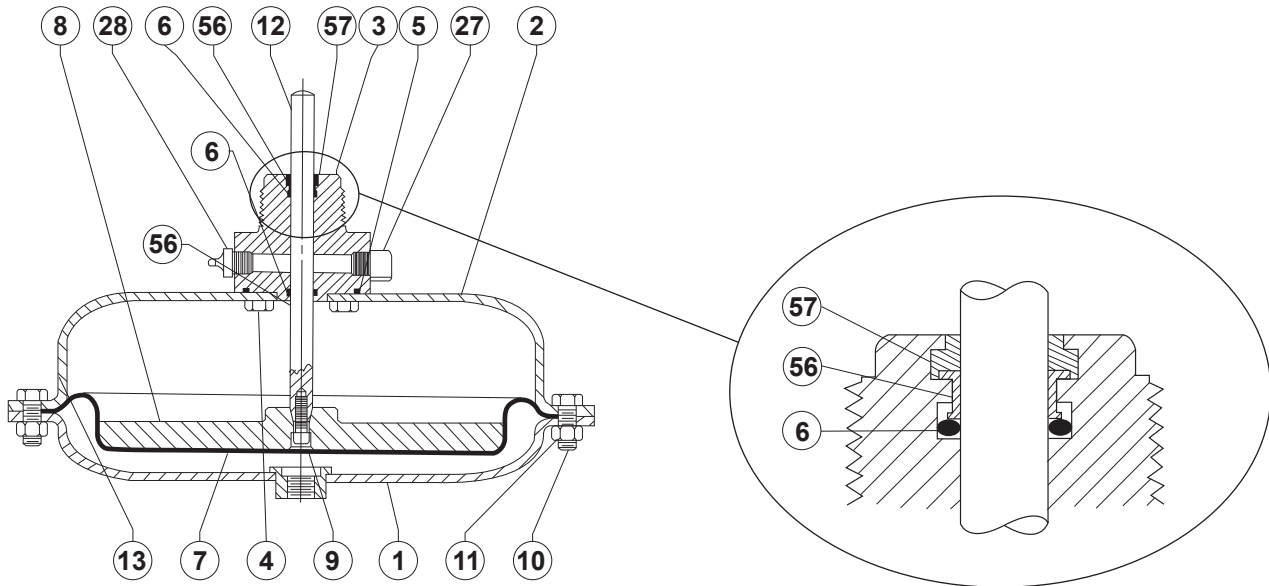

34A5692

TYPE 1098

Figure 13. Types 1098 and 1098H Actuator Assemblies

Types 1098-EGR and 1098H-EGR

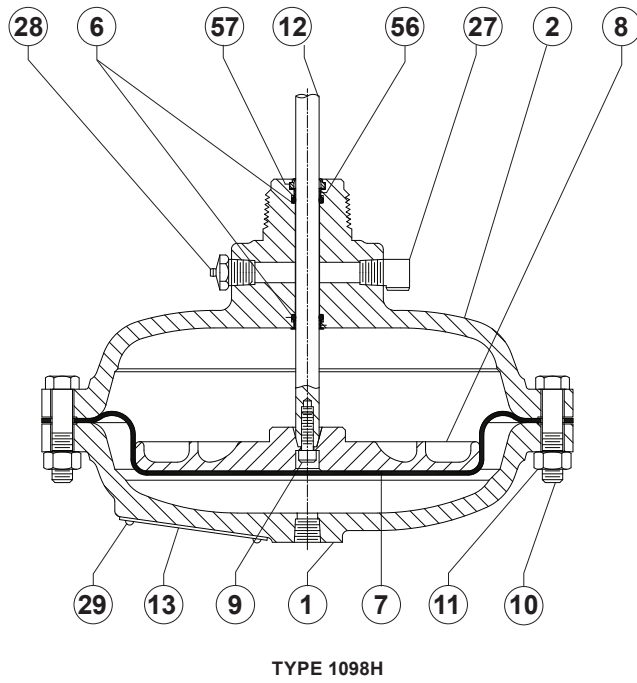

36A8540

Figure 13. Types 1098 and 1098H Actuator Assemblies (continued)

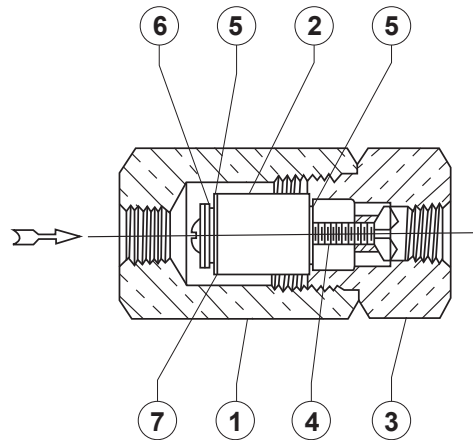

AJ5004

Figure 14. Standard P590 Series Filter Assembly

Types 1098-EGR and 1098H-EGR

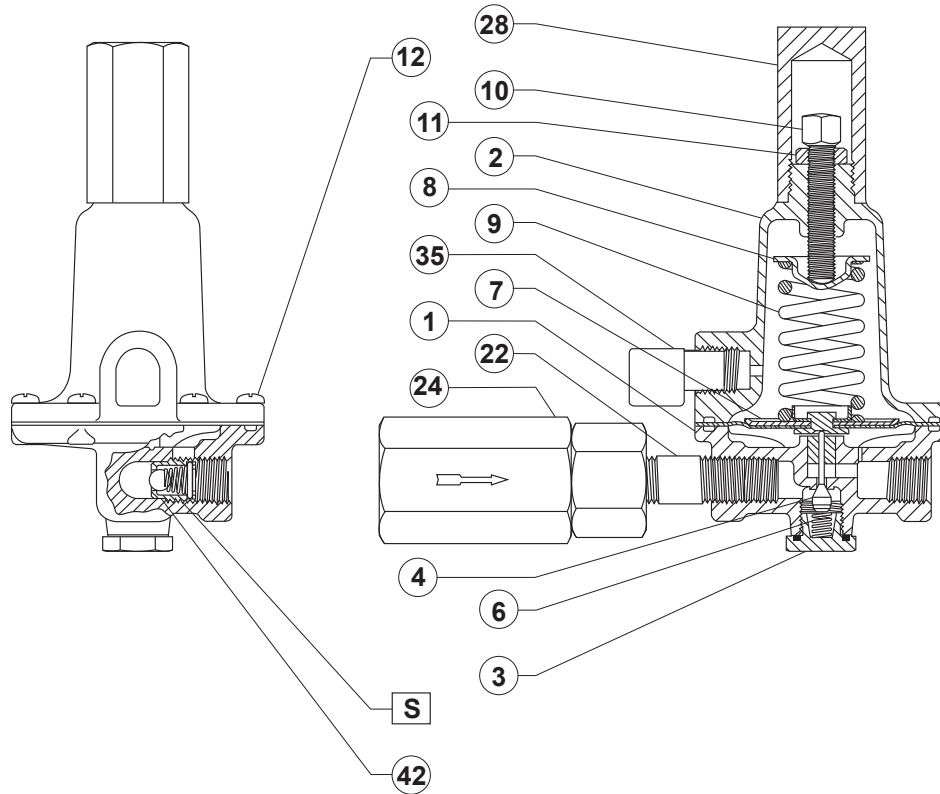

34A5853

□ APPLY SEALANT (S)
S = MULTI-PURPOSE PTFE THREAD SEALANT

Figure 15. Type 6351 Pilot Assembly

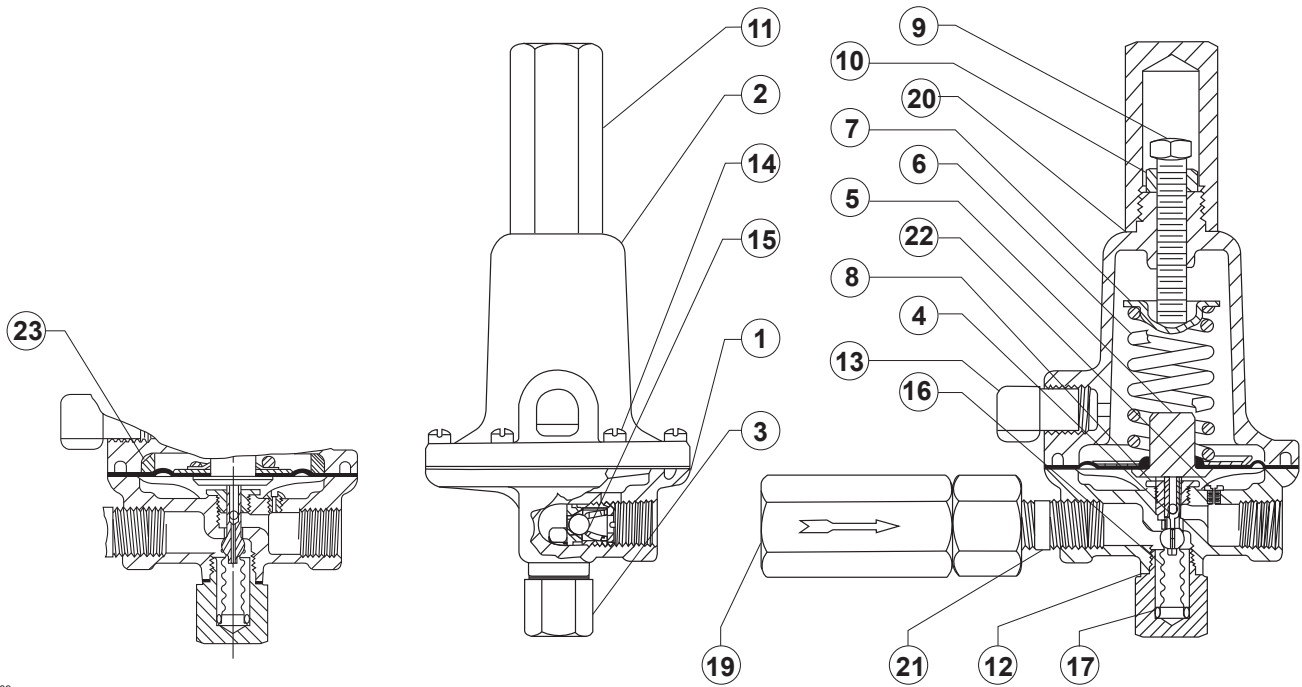

35A8889

35A6236

DETAIL OF TYPE 6354M OR 6354H PILOT

TYPE 6352, 6353 OR 6354L PILOT

Figure 16. Types 6352 through 6354H Pilot Assemblies

Types 1098-EGR and 1098H-EGR

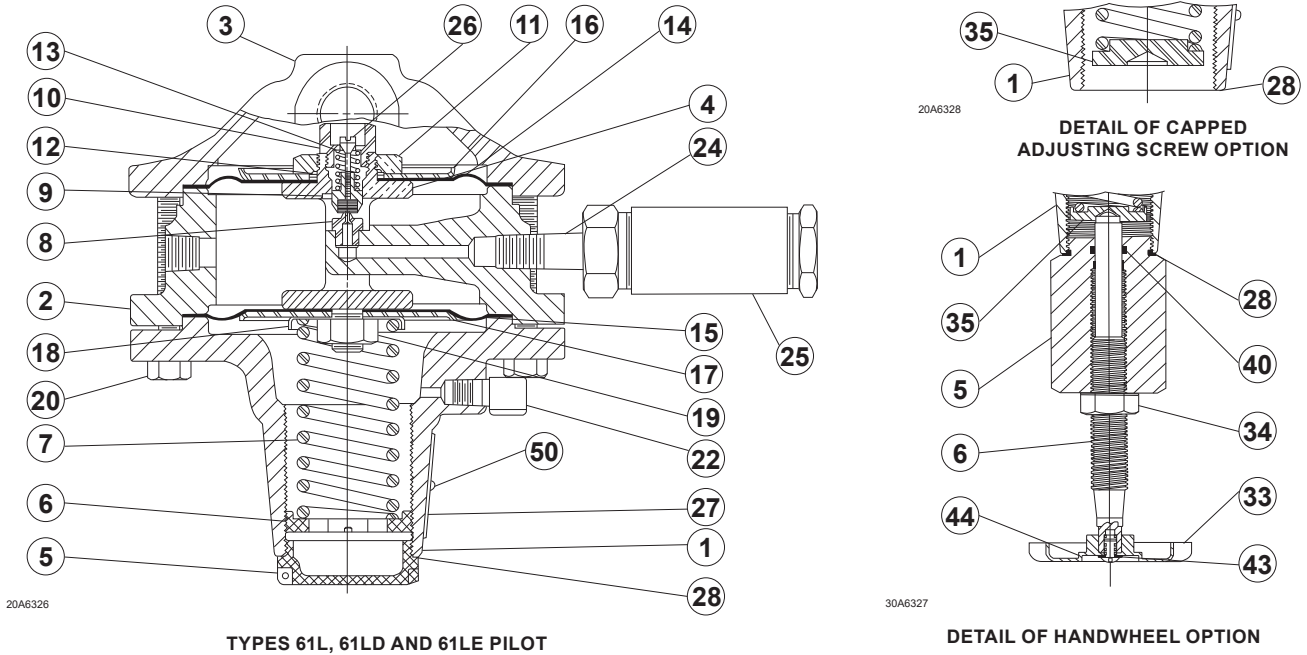

Figure 17. Types 61L, 61LD and 61LE Pilot Assemblies

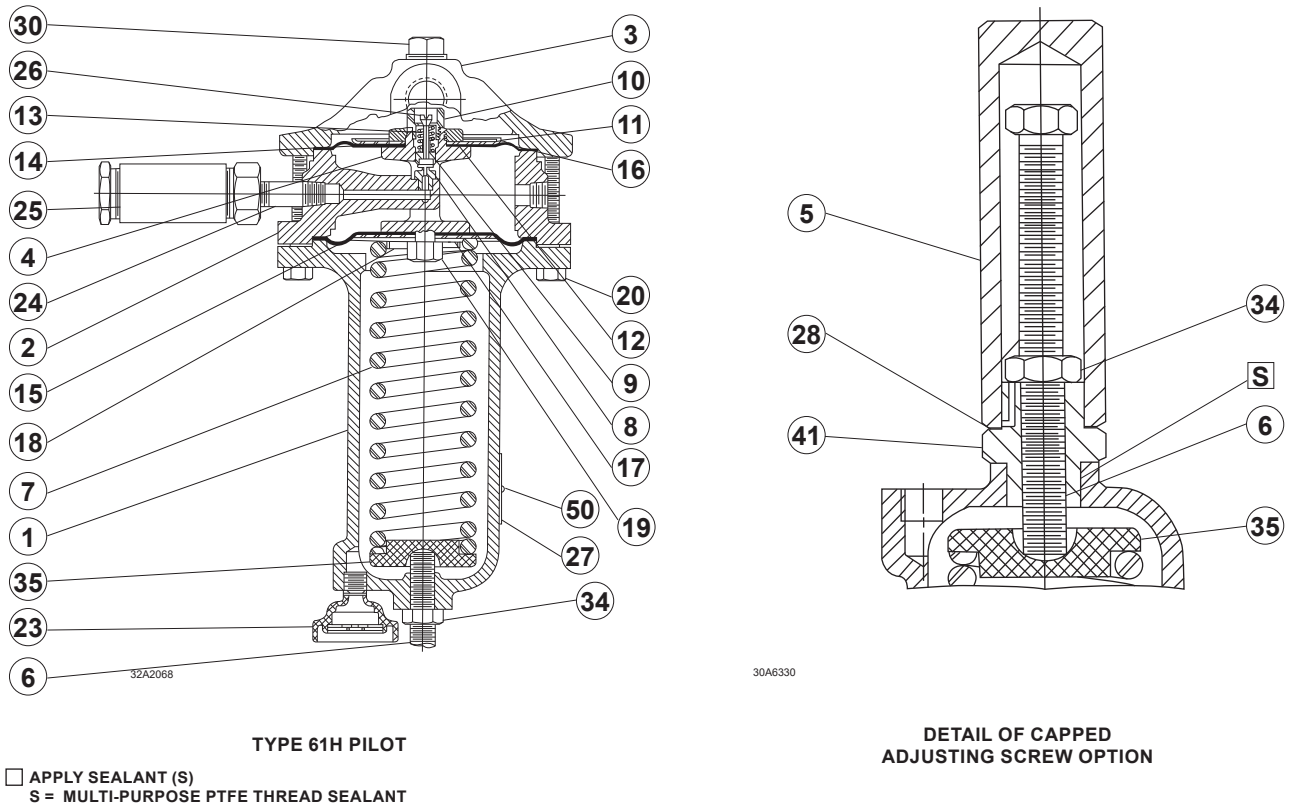
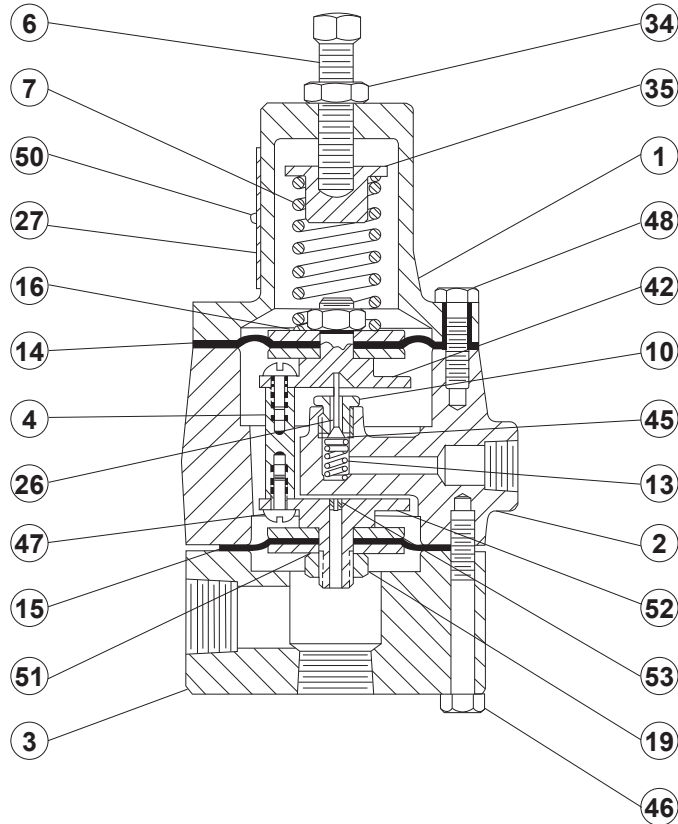

Figure 18. Type 61H Pilot Assembly

Types 1098-EGR and 1098H-EGR



34A0396

Figure 19. Type 61HP Pilot Assembly

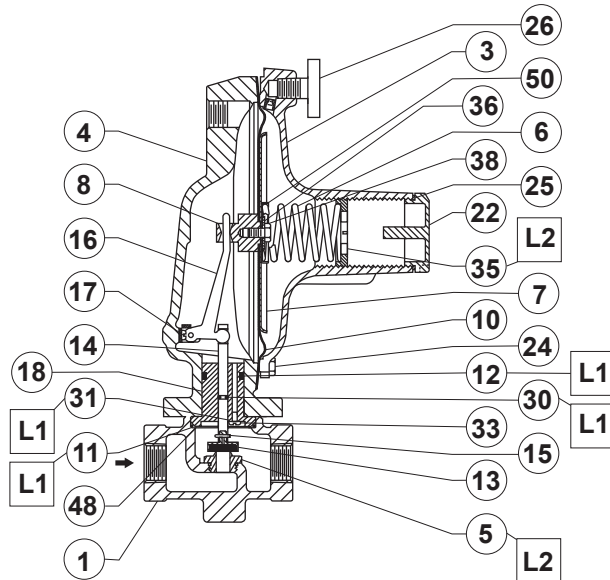

47B3687

- APPLY LUBRICANT (L)
- L1 = SILICONE GREASE LUBRICANT
- L2 = ANTI-SEIZE AND LUBRICATING COMPOUND

Figure 20. Type Y600AM Regulator Assembly

Types 1098-EGR and 1098H-EGR

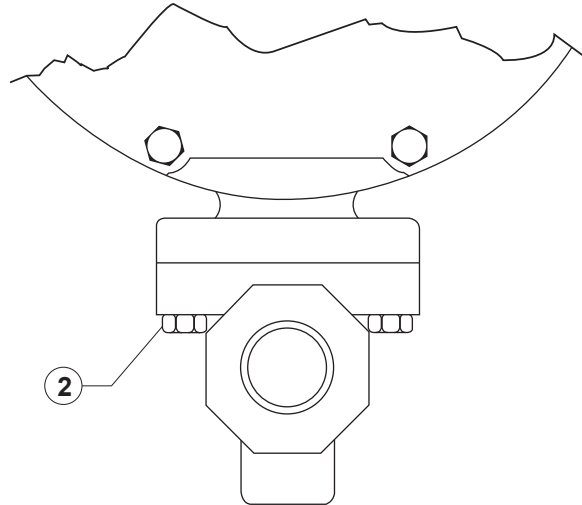

47B3687

Figure 21. Diaphragm Casing Cap Screw Location

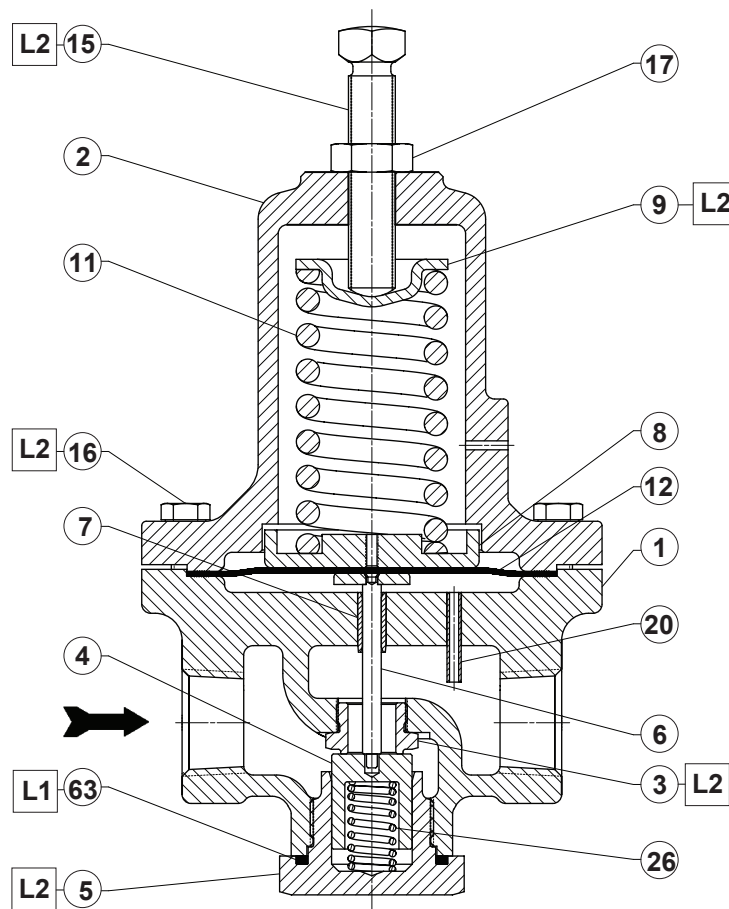

GF04914

□ APPLY LUBRICANT OR SEALANT⁽¹⁾:
 L1 = GENERAL PURPOSE PTFE OR LITHIUM GREASE
 L2 = ANTI-SEIZE COMPOUND

1. Lubricants must be selected such that they meet the temperature requirements.

Figure 22. Type MR95H Supply Pressure Regulator

Types 1098-EGR and 1098H-EGR

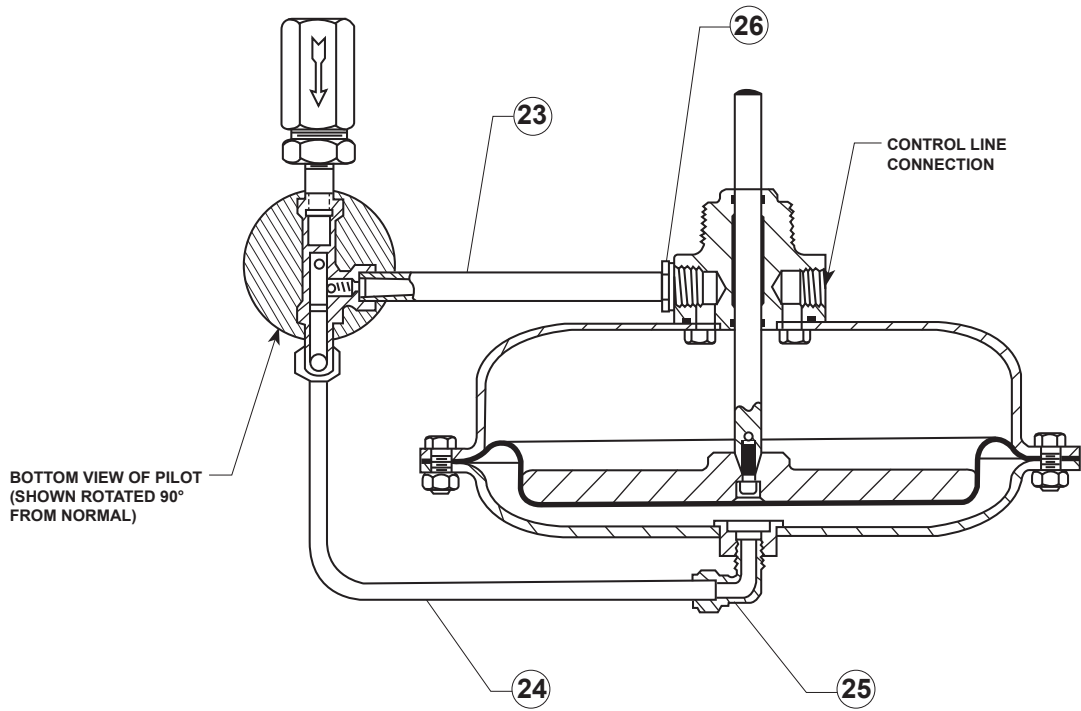

Figure 23. Single-Pilot Mounting Assembly

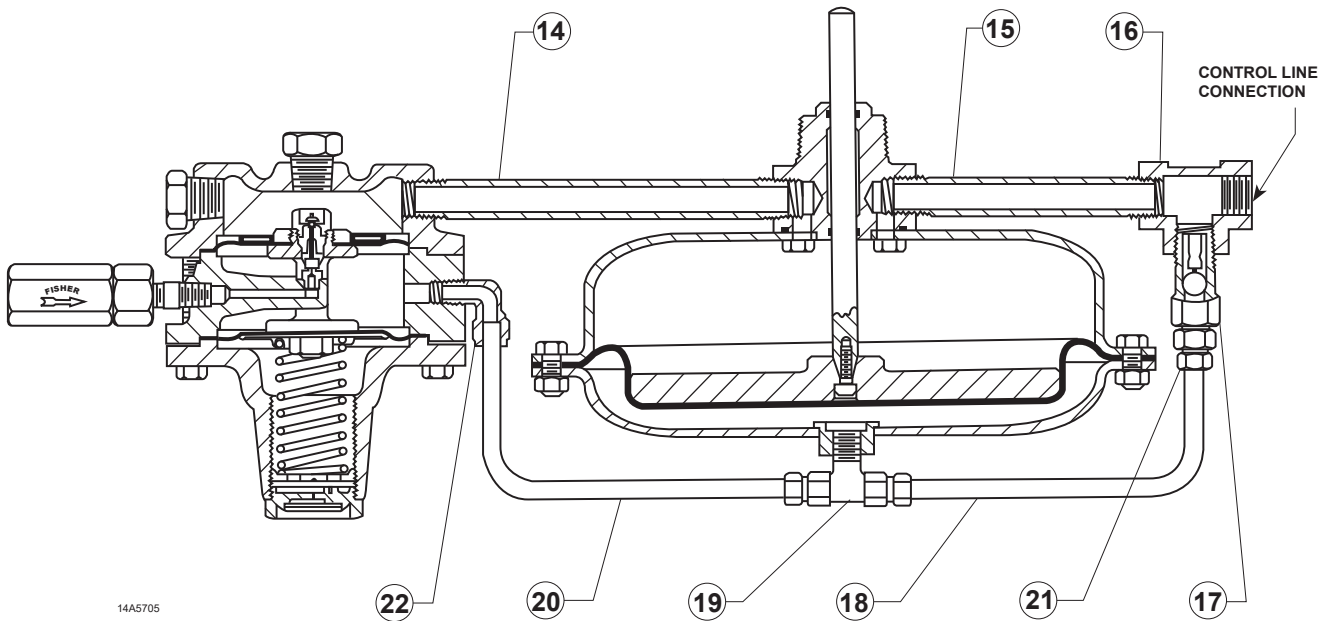
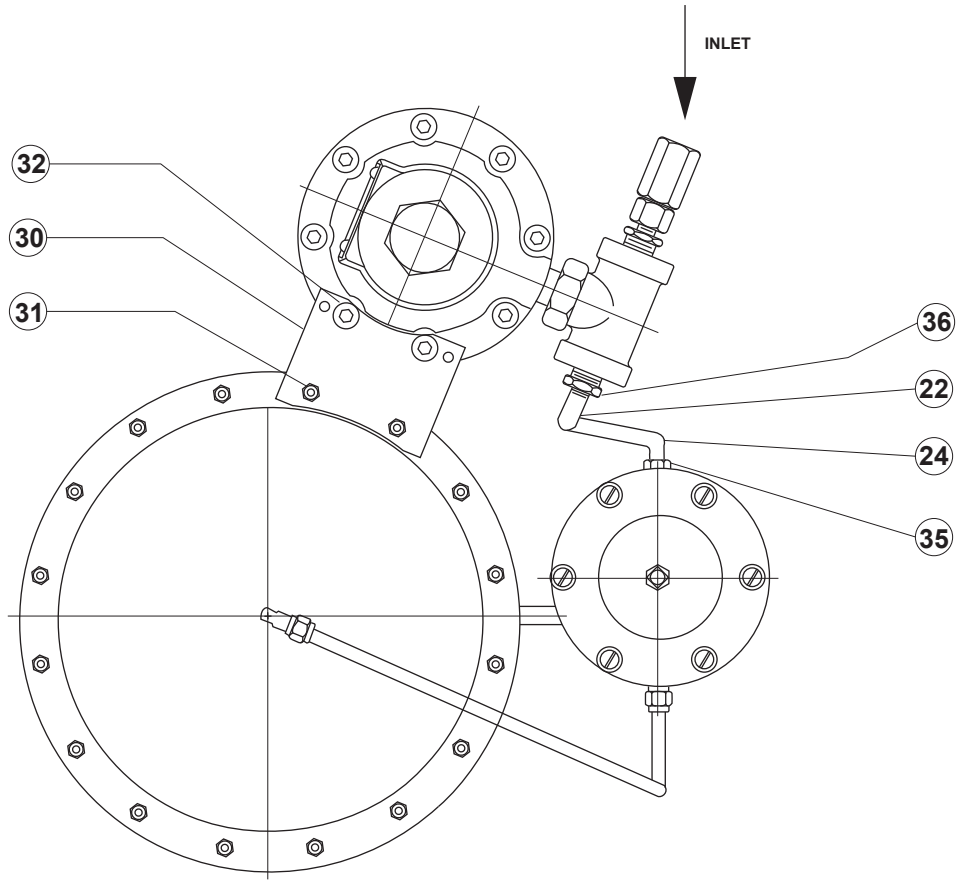

Figure 24. 61 Series Pilot and Type 1806 Check Valve Mounting

Types 1098-EGR and 1098H-EGR



37A0565

Figure 25. Working Monitor Assembly

Types 1098-EGR and 1098H-EGR

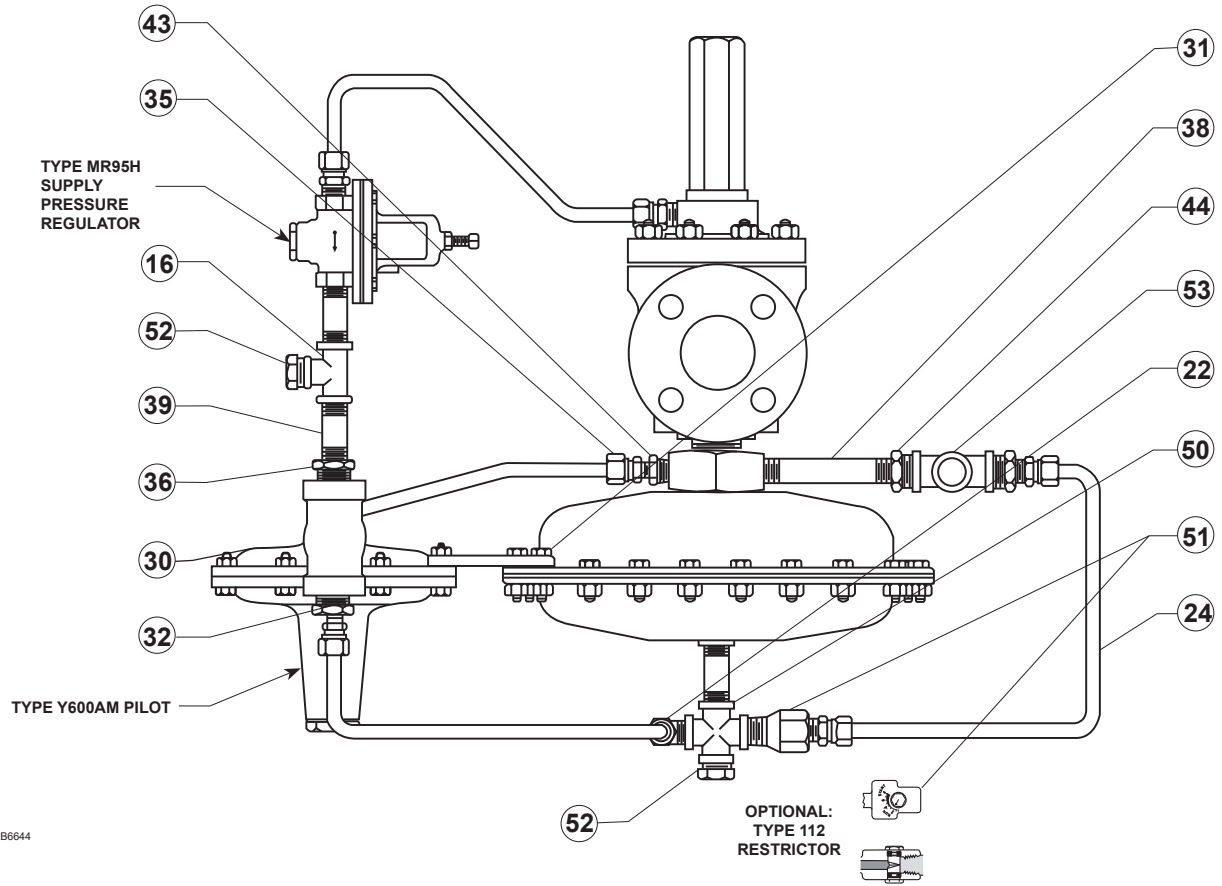

42B6644

Figure 26. Type 1098-EGR with Type Y600AM Mounting Parts

Types 1098-EGR and 1098H-EGR

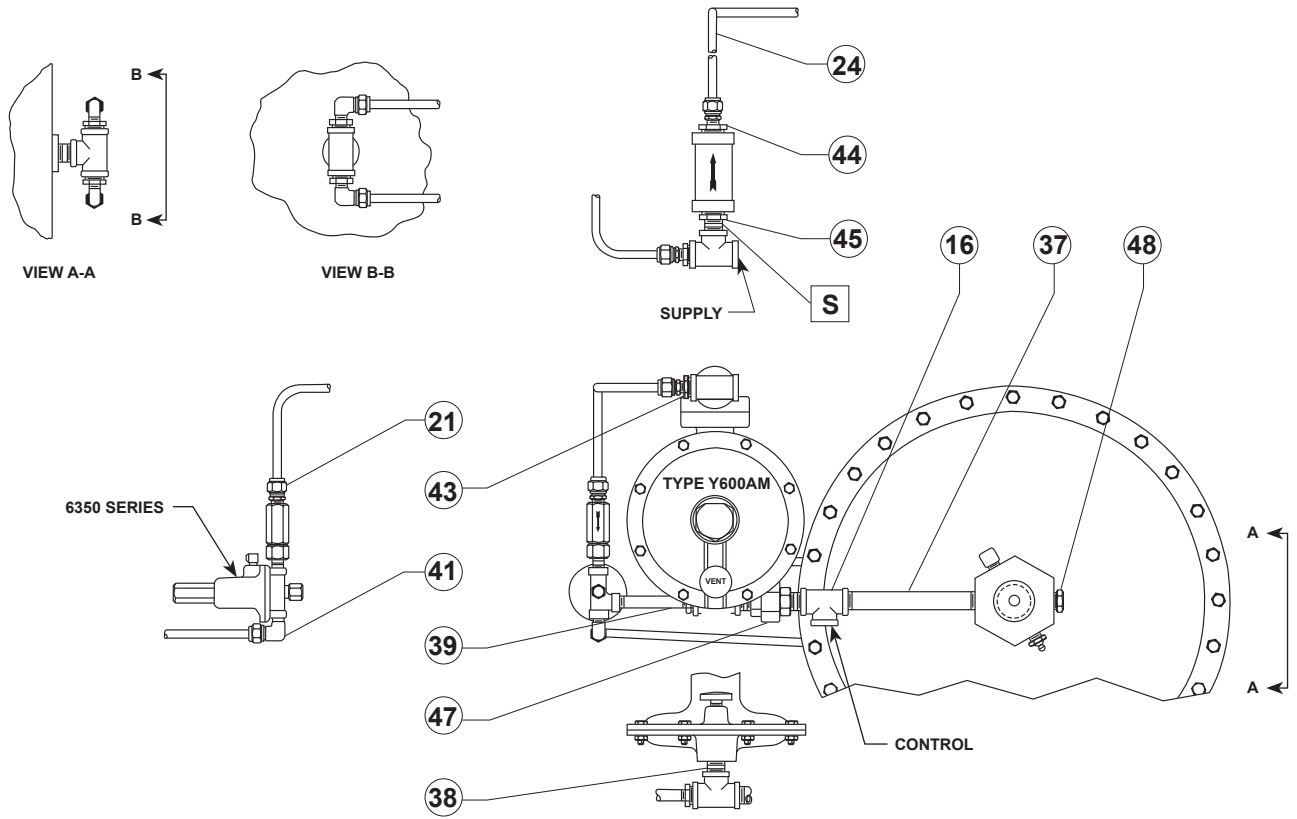

47A7118

TYPE Y600AM AND SIZE 70 TYPE 1098 COMBINATION

□ APPLY SEALANT (S) ALL NPT THREAD

Figure 27. Boiler Fuel Pressure Control Assembly

Types 1098-EGR and 1098H-EGR

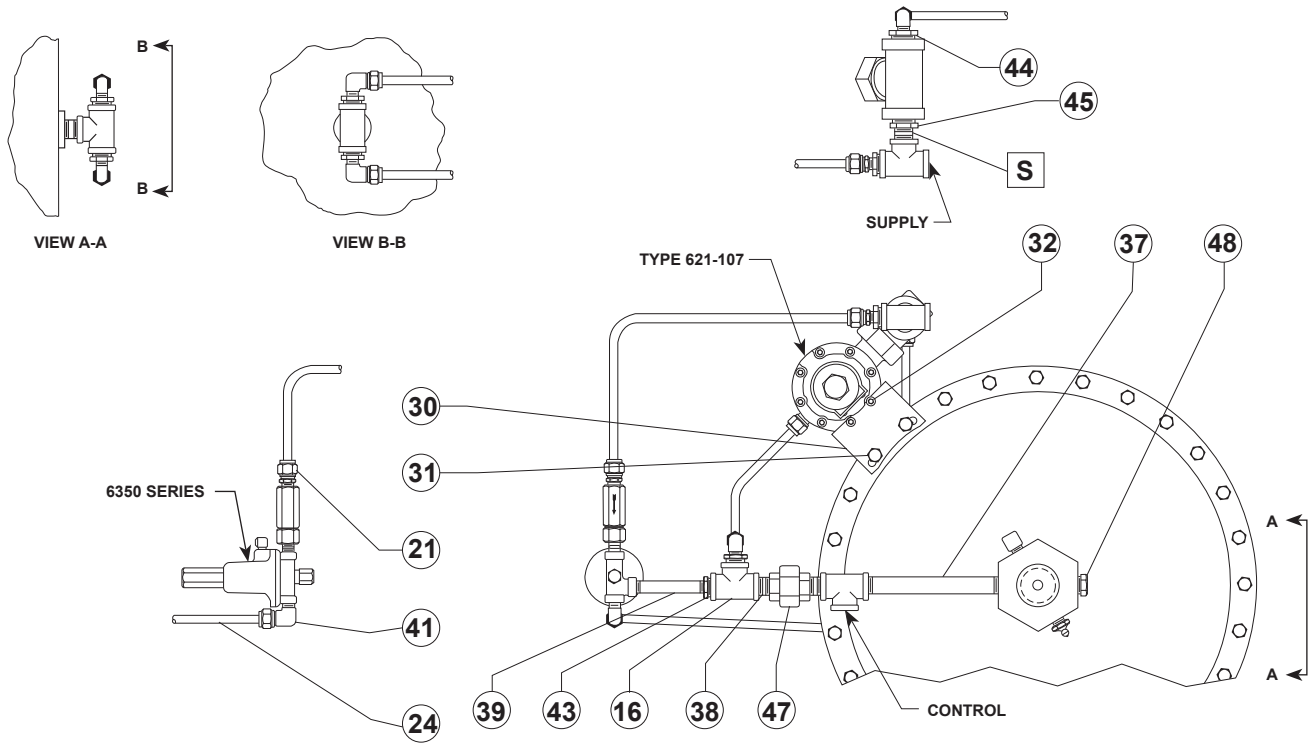

47A7119

TYPE 627M AND SIZE 70 TYPE 1098 COMBINATION

□ APPLY SEALANT (S) ALL NPT THREAD

Figure 27. Boiler Fuel Pressure Control Assembly (continued)

Key 1, Type EGR Main Valve Bodies

MATERIAL	END CONNECTION	NPS 1 / DN 25	NPS 2 / DN 50
Cast Iron	NPT	34B7611X012	38A8845X012
	CL125 FF	34B8630X012	38A8847X012
WCC Steel	NPT	37B5946X012	38A8848X012
	CL150 RF	37B5947X012	38A8853X012
	CL300 RF	37B5948X012	38A8849X012
	CL600 RF	37B5949X012	38A8844X012
	SWE	GE05951X012	GE05958X012
	SCH 40 BWE	GE05953X012	GE05957X012
	PN 16/25/40	GE05956X012	GE05960X012
CF8M Stainless steel / NACE	NPT	37B5946X032	38A8848X032
	CL150 RF	37B5947X032	38A8853X072
	CL300 RF	37B5948X032	38A8849X032
	CL600 RF	37B5949X032	38A8844X032
	SWE	GE05951X022	GE05958X022
	SCH 40 BWE	GE05953X022	GE05957X022
	PN 16/25/40	GE05956X022	GE05960X022
NACE WCC Steel	NPT	-----	38A8848X022
	CL150 RF	37B5947X022	38A8853X052
	CL300 RF	37B5948X022	38A8849X022
	CL600 RF	37B5949X022	38A8844X022

Types 1098-EGR and 1098H-EGR

Key 1, Type EGR Main Valve Bodies (continued)

MATERIAL	END CONNECTION	NPS 3 / DN 80	NPS 4 / DN 100	NPS 6 / DN 150	NPS 8 x 6 / DN 200 x 150
Cast Iron	CL125 FF	38A8851X012	38A8865X012	38A8875X012	-----
WCC Steel	CL150 RF	38A8872X012	38A8867X012	38A7115X012	GE05973X012
	CL300 RF	38A8871X012	38A8869X012	38A8873X012	GE05974X012
	CL600 RF	38A8852X012	38A8866X012	38A8874X012	GE05975X012
	SCH 40 BWE	GE05962X012	GE05967X012	GE05971X012	-----
	PN 16	GE05965X012	GE05969X012	GE05972X012	-----
CF8M Stainless steel / NACE	CL150 RF	38A8872X052	38A8867X042	38A7115X032	-----
	CL300 RF	38A8871X052	38A8869X032	38A8873X032	-----
	CL600 RF	38A8852X042	38A8866X032	38A8874X032	-----
	SCH 40 BWE	GE05962X022	GE05967X022	GE05971X022	GE05976X022
	PN 16	GE05965X022	GE05969X022	GE05972X022	-----
NACE WCC Steel	CL150 RF	38A8872X062	38A8867X032	38A7115X022	GE05973X022
	CL300 RF	38A8871X042	38A8869X022	38A8873X022	GE05974X022
	CL600 RF	38A8852X032	38A8866X022	38A8874X022	GE05975X022

Key 9, Spring

BODY SIZE		SPRING						
		Standard (Steel)				NACE (Inconel® X-750)		
NPS	DN	20 psi / 1.4 bar, Yellow	60 psi / 4.1 bar, Green	125 psi / 8.6 bar, Blue	400 psi / 27.6 bar, Red	60 psi / 4.1 bar, Green	125 psi / 8.6 bar, Blue	400 psi / 27.6 bar, Red
1	25	----	14A9687X012	14A9680X012	14A9679X012	11B6769X012	12B8326X012	10B1882X012
2	50	14A6768X012	14A6626X012	14A6627X012	14A6628X012	16A5501X012	16A5995X012	16A5499X012
3	80	14A6771X012	14A6629X012	14A6630X012	14A6631X012	16A5503X012	16A5996X012	16A5500X012
4	100	14A6770X012	14A6632X012	14A6633X012	14A6634X012	16A5506X012	16A5997X012	16A5998X012
6, 8 x 6 or 12 x 6	150, 200 x 150 or 300 x 150	15A2253X012	14A9686X012	14A9685X012	15A2615X012	16A5510X012	16A5999X012	16A6000X012

Types 1098-EGR and 1098H-EGR

 Webadmin.Regulators@emerson.com

 Fisher.com

 Facebook.com/EmersonAutomationSolutions

 LinkedIn.com/company/emerson-automation-solutions

 Twitter.com/emr_automation

Emerson

Americas

McKinney, Texas 75070 USA
T +1 800 558 5853
+1 972 548 3574

Europe

Bologna 40013, Italy
T +39 051 419 0611

Asia Pacific

Singapore 128461, Singapore
T +65 6777 8211

Middle East and Africa

Dubai, United Arab Emirates
T +971 4 811 8100

D100339X012 © 2001, 2024 Emerson Process Management Regulator Technologies, Inc. All rights reserved. 03/24.

The Emerson logo is a trademark and service mark of Emerson Electric Co. All other marks are the property of their prospective owners. Fisher™ is a mark owned by Fisher Controls International LLC, a business of Emerson Automation Solutions.

The contents of this publication are presented for informational purposes only, and while every effort has been made to ensure their accuracy, they are not to be construed as warranties or guarantees, express or implied, regarding the products or services described herein or their use or applicability. All sales are governed by our terms and conditions, which are available upon request. We reserve the right to modify or improve the designs or specifications of such products at any time without notice.

Emerson Process Management Regulator Technologies, Inc. does not assume responsibility for the selection, use or maintenance of any product. Responsibility for proper selection, use and maintenance of any Emerson Process Management Regulator Technologies, Inc. product remains solely with the purchaser.

