

April 2021

Type 92S Pilot-Operated Steam Regulators



WARNING

Failure to follow these instructions or to properly install and maintain this equipment could result in an explosion, fire and/or chemical contamination causing property damage and personal injury or death.

Fisher™ regulators must be installed, operated and maintained in accordance with federal, state and local codes, rules and regulations and Emerson Process Management Regulator Technologies, Inc. instructions.

If the regulator vents gas or a leak develops in the system, service to the unit may be required. Failure to correct trouble could result in a hazardous condition.

Installation, operation and maintenance procedures performed by unqualified personnel may result in improper adjustment and unsafe operation. Either condition may result in equipment damage or personal injury. Use qualified personnel when installing, operating and maintaining the Type 92S Pilot-Operated Steam regulator.

Introduction

Scope of the Manual

This manual provides instruction for installation, adjustment, maintenance and parts ordering information for the Type 92S Pilot-Operated Steam Regulator complete with Type 6492L, 6492H or 6492HT pilot. The Type 92S is also available with a Type 6492HM or 6492HTM safety override pilot. Accessories used with this valve, including any pressure-loading device for a Type 6492L, 6492H, 6492HT, 6492HM or 6492HTM pilot with tapped spring case, are covered in other manuals.

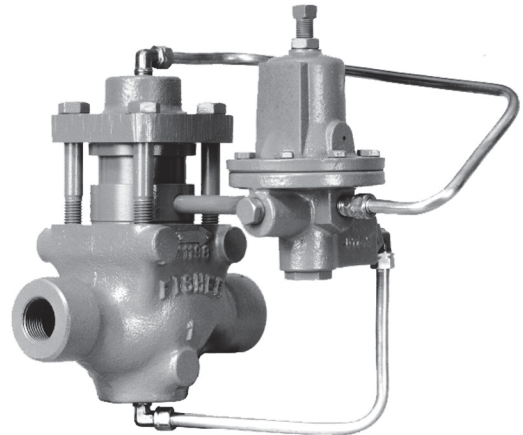

W4086-3

1 NPT STEEL MAIN VALVE WITH TYPE 6492H OR 6492HT PILOT

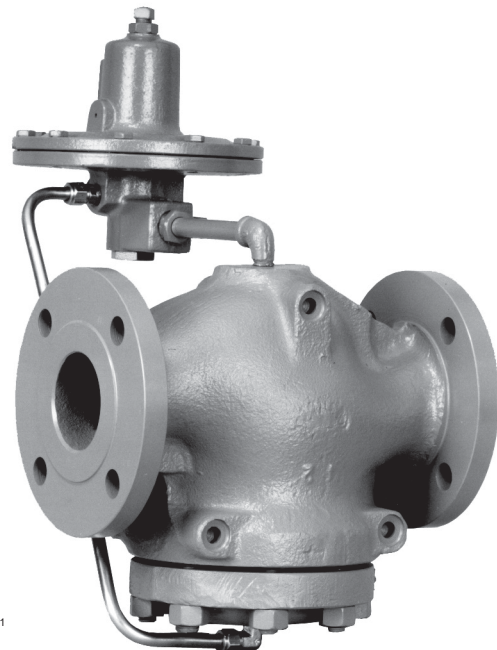

W4088-1

NPS 3 / DN 80 FLANGED CAST IRON
MAIN VALVE WITH TYPE 6492L PILOT

Figure 1. Type 92S Pilot-Operated Steam Regulator

Type 92S

Specifications

The Specifications section lists the specifications for the Type 92S regulator. Specifications for a given regulator as it originally comes from the factory are stamped on nameplates located on both the main valve body and pilot, while the pilot control spring range is displayed on the pilot spring case.

Main Valve Body Sizes and End Connection Styles

BODY SIZE	END CONNECTION STYLES AND RATINGS	
	Cast Iron Body	Steel or Stainless Steel Body
1, 1-1/2 and 2	NPT	NPT
NPS 1, 1-1/2, 2, 2-1/2, 3 and 4 / DN 25, 40, 50, 65, 80 and 100	CL125 FF or CL250 RF	CL150 RF, CL300 RF, CL600 RF or PN 10/25/40
NPS 6 x 4 / DN 150 x 100 ⁽²⁾	Not Available	CL300 RF, CL600 RF or PN 16/25-40/64/100

Maximum Inlet and Pilot Supply Pressure⁽¹⁾

Cast Iron Main Valve and Pilot: 250 psig / 17.2 bar or body rating limit, whichever is lower
Steel or Stainless steel Main Valve and Pilot: 300 psig / 20.7 bar or body rating limit, whichever is lower

Minimum and Maximum Differential Pressures⁽¹⁾

BODY SIZE, NPS / DN	MINIMUM DIFFERENTIAL PRESSURE	MAXIMUM DIFFERENTIAL PRESSURE
1, 1-1/2 and 2 / 25, 40 and 50	15 psi / 1.0 bar	200 psi / 13.8 bar or body rating limit, whichever is lower
2-1/2, 3, 4 and 6 x 4 / 65, 80, 100 and 150 x 100 ⁽²⁾	20 psi / 1.4 bar	175 psi / 12.1 bar or body rating limit, whichever is lower

Outlet (Control) Pressure Ranges

See Table 2

Maximum Outlet Pressures⁽¹⁾

See Table 3

Maximum Allowable Loading Pressure for Pilot with Tapped Spring Case⁽¹⁾

Combination of pilot control spring setting and spring case loading pressure must not exceed 150 psig / 10.3 bar for Type 6492H pilot or 25 psig / 1.7 bar for Type 6492L pilot and 250 psig for Type 6492HT

Pressure Registration

External through downstream control line

Maximum Material Temperature Capabilities⁽¹⁾

Cast Iron Construction: 406°F / 208°C
Steel Construction: 500°F / 260°C
High Temperature Optional Steel and Stainless steel Construction: 650°F / 343°C

Main Valve Port Diameters and Flow Coefficients

See Table 1

Downstream Control Line Connections

NPS 1, 1-1/2 or 2 / DN 25, 40 or 50 Body Size: 1/4 NPT in main valve cylinder spacer
NPS 2-1/2, 3, 4 or 6 x 4 / DN 65, 80, 100 or 150 x 100⁽²⁾ Body Size: 1/4 NPT in pilot body

Pilot Spring Case Vent

Standard: 1/8 in. / 3.2 mm drilled hole
Optional: 1/4 NPT tapping for pressure loading or on-off service

Approximate Weights

BODY SIZE		END CONNECTION STYLE	APPROXIMATE WEIGHTS			
NPS	DN		Lbs	kg		
1	25	NPT or Flanged	32	15		
	40		44	20		
2	50	NPT Flanged	55	25		
			67	30		
2-1/2	65	Flanged	90	41		
			3	80	115	52
				100	165	75
6 x 4 ⁽²⁾	150 x 100 ⁽²⁾	Flanged	CL300	335	152	
			CL600	435	197	

1. The pressure/temperature limits in this Instruction Manual or any applicable standard limitation should not be exceeded.

2. The two-number designation indicates end connection size by trim size.

Table 1. Flow and Sizing Coefficients⁽¹⁾

BODY SIZE		ORIFICE SIZE		REGULATING C _s	WIDE-OPEN C _s FOR RELIEF SIZING	C ₁	K _m	IEC SIZING COEFFICIENTS		
NPS	DN	In.	mm					X _T	F _D	F _L
1	25	7/8	22	16	17.5	34	0.62	0.73	0.51	0.79
1-1/2	40	1-1/8	29	30	33				0.47	
2	50	1-29/64	37	48	52				0.48	
2-1/2	65	1-5/8	41	74	78		0.71		0.48	0.84
3	80	2-1/16	52	100	110				0.47	
4	100	2-3/8	60	140	145				0.46	
6 x 4	150 x 100	2-3/8	60	150	155		0.46			

1. C_v = C_s x 20 ÷ C₁

Table 2. Outlet (Control) Pressure Ranges

PILOT TYPE	OUTLET PRESSURE RANGES		PART NUMBER	COLOR CODE	SPRING WIRE DIAMETER		SPRING FREE LENGTH	
	psig	bar			In.	mm	In.	mm
6492L	2 to 6	0.14 to 0.41	1E395627022	Yellow	0.207	5.26	2.50	63.5
	5 to 15	0.34 to 1.0	1D7455T0012	Green	0.234	5.94	2.62	66.5
	13 to 25	0.90 to 1.7	1E395727192	Red	0.283	7.19	2.44	62.0
6492H	10 to 30	0.69 to 2.1	1E395627022	Yellow	0.207	5.26	2.50	63.5
	25 to 75	1.7 to 5.2	1D7455T0012	Green	0.234	5.94	2.62	66.5
	70 to 150	4.8 to 10.3	1E395727192	Red	0.283	7.19	2.44	62.0
6492HT	15 to 100	1.0 to 6.9	14B9943X012	Unpainted	0.282	7.16	2.50	63.5
	80 to 250	5.5 to 17.2	14B9942X022		0.375	9.53	2.50	63.5

Table 3. Maximum Inlet and Outlet Pressures

CONSTRUCTION	MAXIMUM ALLOWABLE INLET PRESSURE				MAXIMUM OPERATING OUTLET PRESSURE		MAXIMUM EMERGENCY OUTLET PRESSURE	
	Cast Iron		Steel and Stainless Steel				Cast Iron Main Valve and Pilot Body	Steel or Stainless Steel Main Valve and Pilot Body
	psig	bar	psig	bar	psig	bar		
With Type 6492HT pilot	----		300	20.7	250	17.2	----	
With Type 6492H pilot	250	17.2			150	10.3	250 psig / 17.2 bar or main valve body rating limit, whichever is lower	300 psig / 20.7 bar or main valve body rating limit, whichever is lower
With Type 6492L pilot					25	1.7	100 psig / 6.9 bar	100 psig / 6.9 bar

Table 4. Safety Pilot Outlet (Control) Pressure Ranges

TYPE	SPRING RANGE		SPRING COLOR	PART NUMBER	MINIMUM PRESSURE AT WHICH MONITORING PILOT CAN BE SET
	psig	bar			
6492HM	10 to 30	0.69 to 2.1	Yellow	1E395627022	5 psig / 0.34 bar over normal distribution pressure
	25 to 75	1.7 to 5.2	Green	1D7455T0012	
	70 to 150	4.8 to 10.3	Red	1E395727192	
6492HTM	15 to 100	1.0 to 6.9	Unpainted	14B9943X012	10 psig / 0.69 bar over normal distribution pressure
	80 to 250	5.5 to 17.2		14B9942X022	

Description

The Type 92S pressure-reducing regulator for steam service includes either a Type 6492H, 6492HT or 6492L pilot (Figure 1). Both pilots have a friction-reducing bellows seal on the stem and offer pressure-setting adjustment plus sensitivity to downstream pressure changes.

These pilots are available in either a standard version with a drilled spring case vent or an optional version with a tapped spring case vent and a sealed adjusting screw for pressure-loading or on-off service. A 67 or 1301 Series regulator or 670 Series panel-mounted regulator may be used to load the pilot of a version for pressure-loading service, while a solenoid valve may be used on the pilot of a version for on-off service. A Type 6492HM or 6492HTM safety override pilot is available for the Type 92S. The Type 6492H or 6492HT pilot is used in a series installation with the Type 6492HM or 6492HTM safety override pilot installed on the upstream control valve. The Type 6492HM or 6492HTM safety override pilot

senses pressure downstream of the second valve and prevents pressure from rising above safe operating pressure in the event the downstream valve fails. This system is approved by ASME B31.1-1989, 122.14.2.A, and can replace an ASME safety valve when vent piping is not practical and upstream steam pressure does not exceed 400 psig / 27.6 bar. Local codes and standards may require approval by an appropriate authority prior to installation.



WARNING

The Type 92S safety override system does not provide positive shutoff in dead end service. It is intended for large distribution systems where steam leakage will condense before steam pressure builds up. Downstream piping and components must be rated for maximum upstream steam pressure for dead end service. Failure to do so could cause personal injury or death.

Type 92S

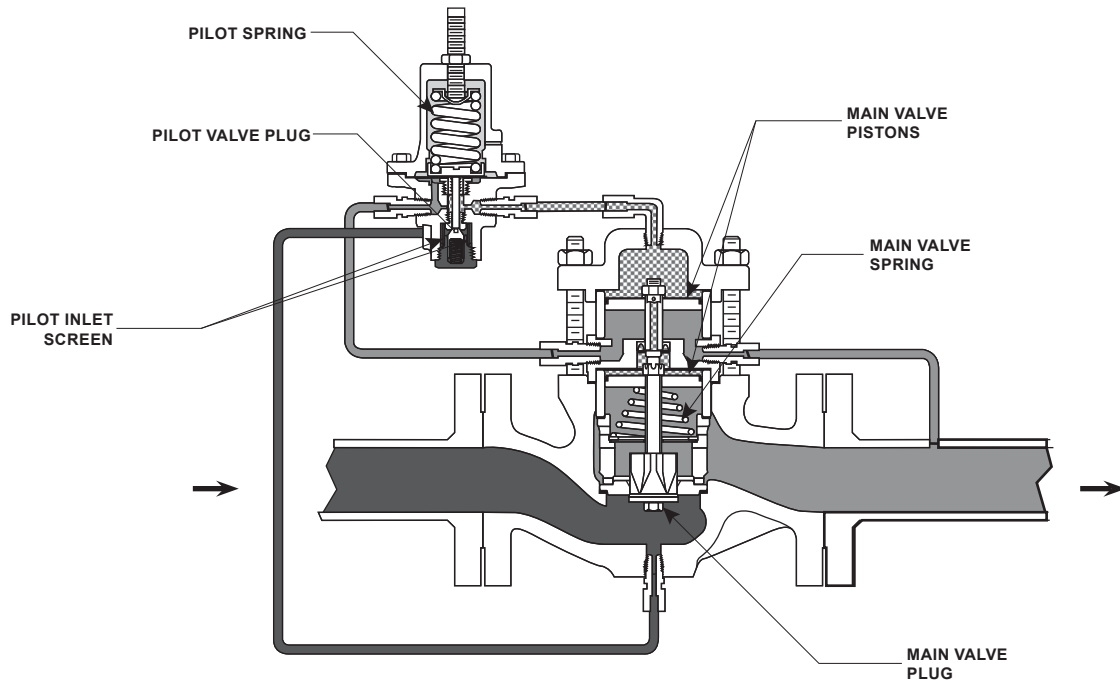

A6552

NPS 1, 1-1/2 OR 2 / DN 25, 40 OR 50 BODY SIZE MAIN VALVE BODY AND TYPE 6492H OR 6492HT PILOT

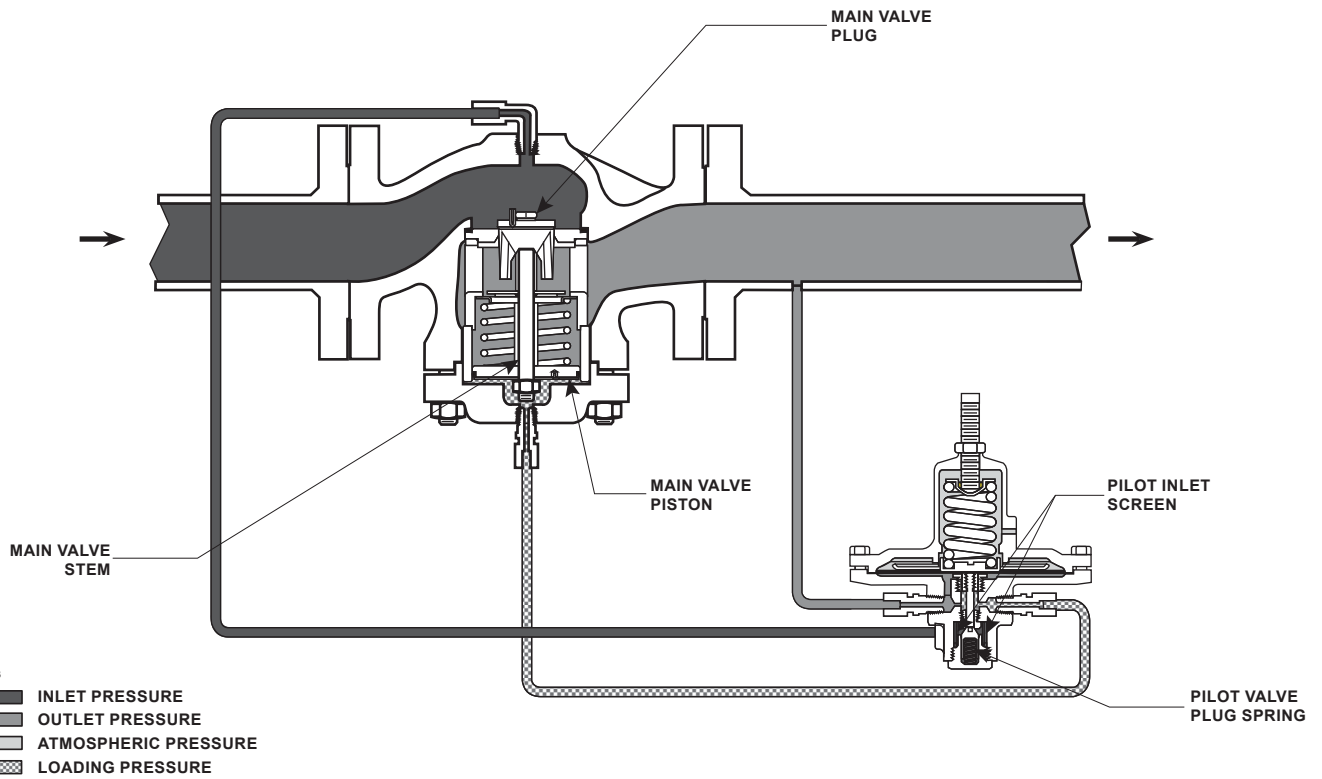

A6553

NPS 2-1/2, 3, 4 OR 6 X 4 / DN 65, 80, 100 OR 150 X 100 BODY SIZE MAIN VALVE BODY AND TYPE 6492L PILOT

Figure 2. Type 92S Pilot-Operated Steam Regulator Operational Schematics

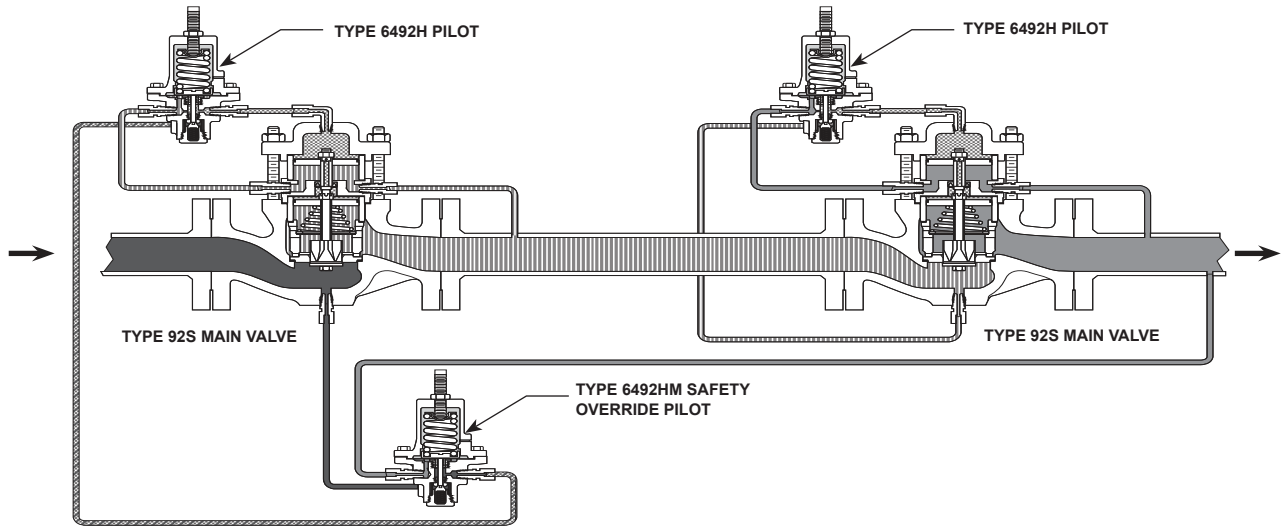

E0402

NPS 1, 1-1/2 AND 2 / DN 25, 40 AND 50 BODY SIZES
 TYPE 92S PILOT-OPERATED PRESSURE REDUCING REGULATOR WITH SAFETY OVERRIDE PILOT

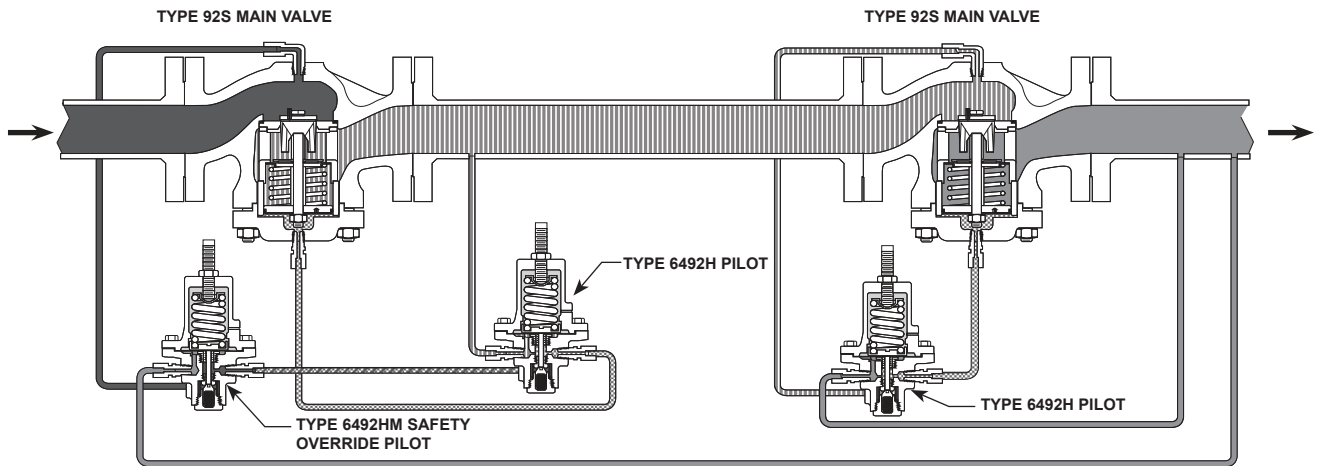

E0403

- INLET PRESSURE
- OUTLET PRESSURE
- ATMOSPHERIC PRESSURE
- LOADING PRESSURE
- INTERMEDIATE PRESSURE

NPS 2-1/2, 3 AND 4 / DN 65 80 AND 100 BODY SIZES
 TYPE 92S PILOT-OPERATED PRESSURE REDUCING VALVE WITH SAFETY OVERRIDE PILOT

Figure 2. Type 92S Pilot-Operated Steam Regulator Operational Schematics (continued)

Principle of Operation

Pilot supply pressure is piped from the main valve inlet (Figure 2) to the pilot inlet connection. Downstream pressure registers on the main valve pistons through the downstream control line and then on the pilot diaphragm.

When increased downstream demand lowers the downstream pressure to a valve below the setting of the pilot control spring, this spring forces the pilot valve plug open to increase the loading pressure on the main valve pistons. At the same time, the increased demand lowers the downstream pressure on the main valve piston(s). This opens the main valve plug, increasing flow to the downstream system to satisfy the increased demand and to restore downstream pressure to the setting of the pilot control spring.

Decreased downstream demand increases the downstream pressure registered on the pilot diaphragm. The increased pressure overcomes the force of the pilot control spring and allows the pilot valve plug spring to close the pilot valve plug. As the pilot valve plug closes, excess loading pressure bleeds to the downstream system through the pilot bleed restriction. At the same time, decreased downstream demand increases the downstream pressure registered on the main valve piston(s). This allows the main valve spring to close the main valve plug, reducing flow to the downstream system in response to the decreased demand.

With a pressure-loaded or on-off pilot, the operation is the same as for a standard pilot except that the pilot control spring force on the pilot valve plug is aided by pneumatic pressure from the loading device or solenoid valve.

Safety Override Pilot Principle of Operation

Once placed in operation, the upstream Type 6492H or 6492HT pilot senses the intermediate pressure between both valves, and the Type 6492HM or 6492HTM pilot senses downstream pressure of the second valve. As demand for flow increases, intermediate pressure will fall causing the Type 6492H or 6492HT pilot to open. As the Type 6492H pilot valve opens, loading pressure to the main valve increases, opening the main valve.

The Type 6492HM or 6492HTM safety override pilot remains open because its setpoint is above the setpoint of the downstream valve. In the unlikely event that the downstream valve fails open, downstream pressure will rise above the downstream valve's setpoint.

This pressure is sensed by the Type 6492HM or 6492HTM safety override pilot. As downstream pressure increases the safety override pilot closes, reducing loading pressure to the main valve, which positions the main valve to maintain downstream pressure as specified per ASME Boiler and Pressure Vessel Code, Section VIII.

In the event that the upstream valve fails, the downstream regulator will prevent downstream pressure from rising above safe operating levels.

It is recommended to install some type of warning system, such as a sentinel relief valve, to warn the operator that a valve has failed in the system. This will prevent prolonged operation with one valve, which could cause valve trim wear and noise associated with operation at high differential pressures.

When operating in most steam systems, valve setpoints should be in strict accordance to ASME Boiler and Pressure Vessel Code, Section VIII. The Type 6492HM or 6492HTM safety override pilot should be set at 10 psig / 0.69 bar or 10% above maximum downstream operating pressure of the second valve, whichever pressure is greater. For example, most HVAC systems operate at 15 psig / 1.0 bar, so the safety override pilot should be set no higher than 25 psig / 1.7 bar.

Installation



Personal injury, equipment damage or leakage due to escaping steam or bursting of pressure-containing parts may result if this regulator is over pressured or is installed where service conditions could exceed the limits given in the Specification section and on the appropriate nameplates or where conditions exceed any ratings of the adjacent piping or piping connections. To avoid such injury or damage, provide pressure-relieving or pressure-limiting devices to prevent service conditions from exceeding those limits.

Additionally, physical damage to the regulator could result in personal injury and property damage due to escaping steam. To avoid such injury and damage, install the regulator in a safe location.

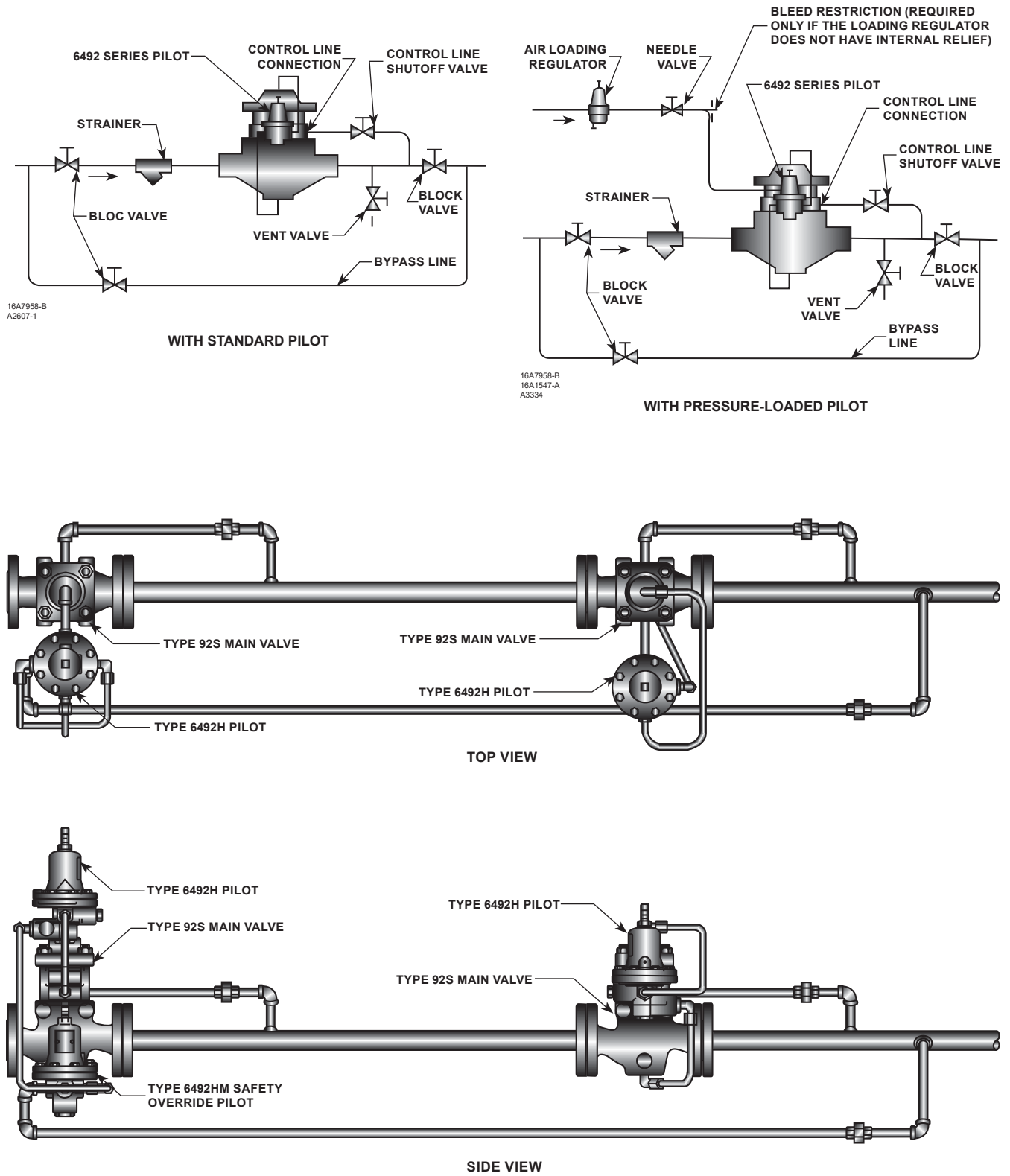
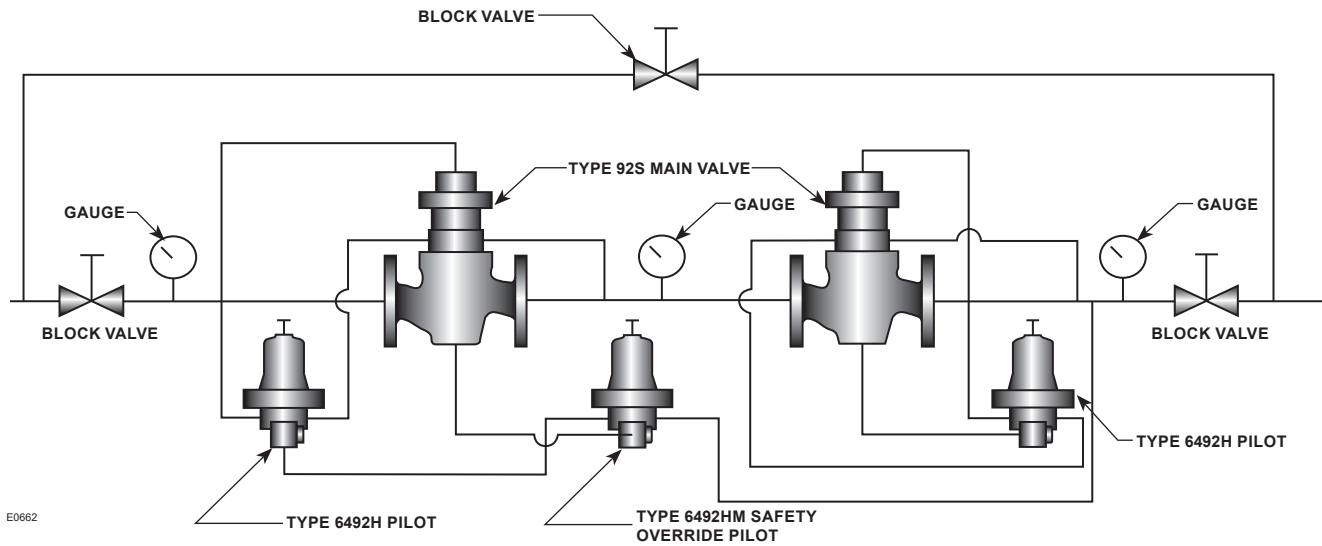
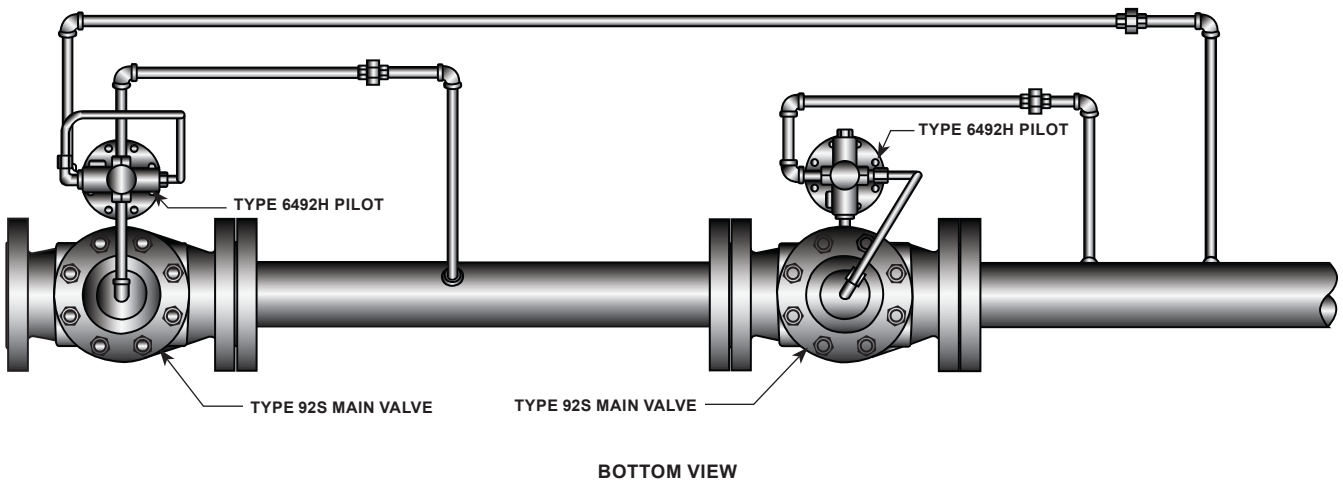

Figure 3. Typical Installations

Type 92S



NPS 1, 1-1/2 AND 2 / DN 25, 40 AND 50 BODY SIZES SAFETY OVERRIDE PIPING SCHEMATICS



BOTTOM VIEW

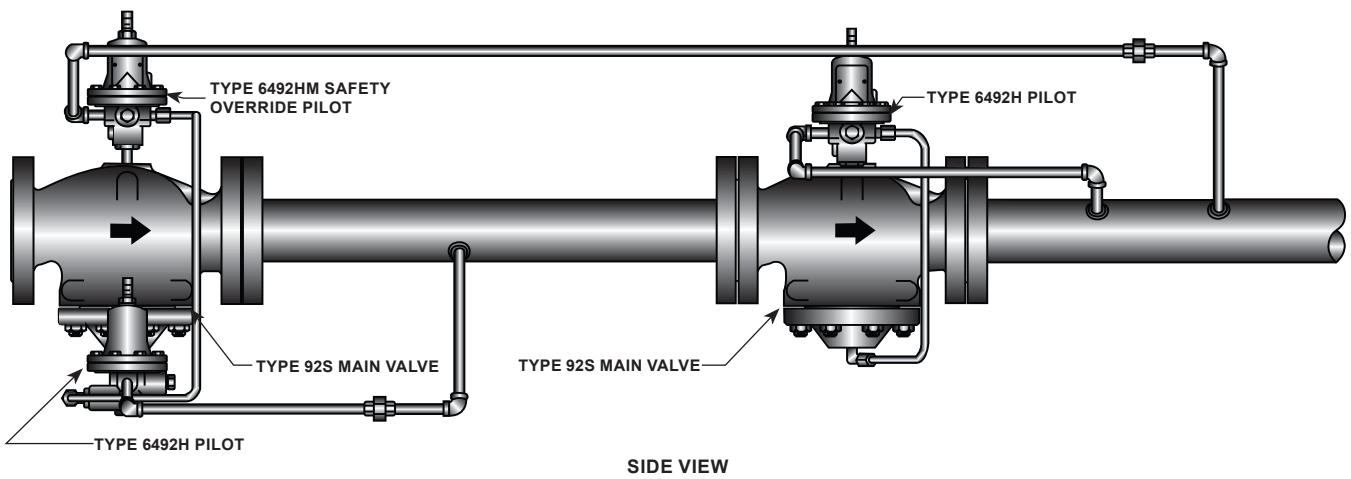

SIDE VIEW

Figure 3. Typical Installations (continued)

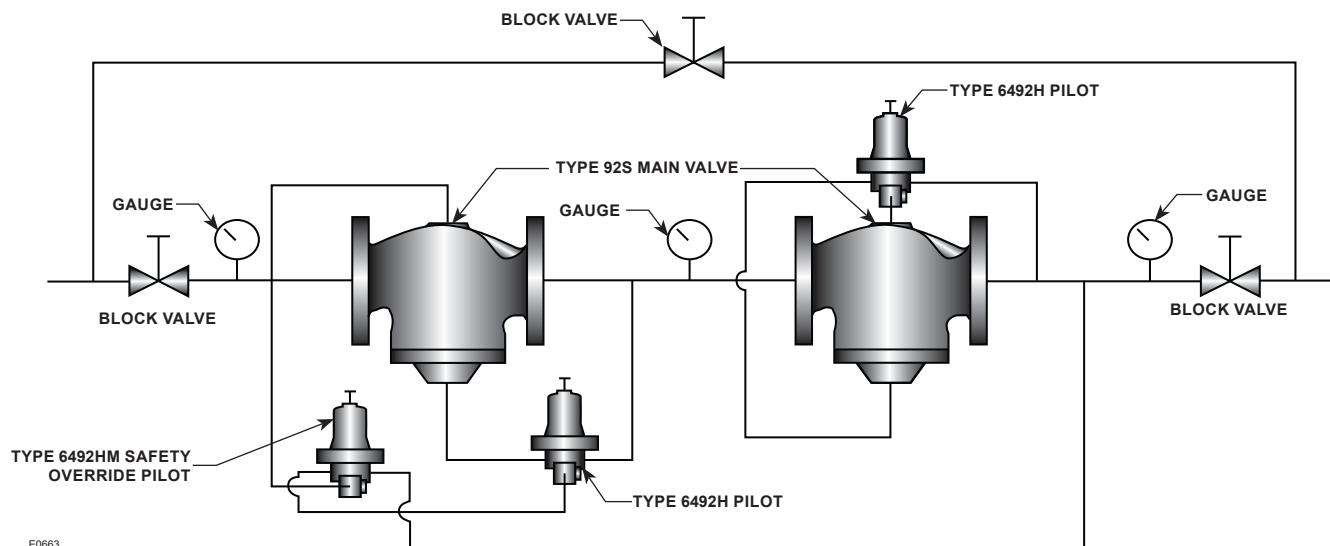

NPS 2-1/2, 3 AND 4 / DN 65, 80 AND 100 BODY SIZES SAFETY OVERRIDE PIPING SCHEMATICS

Figure 3. Typical Installations (continued)

1. Only personnel qualified through training and experience should install, operate and maintain a Type 92S regulator. Before installation, make sure that there is no damage to or debris in the regulator. Also make sure that all tubing and piping are clean and unobstructed.
2. A Type 92S regulator may be installed in any orientation, as long as flow through the regulator matches the direction of the arrow on the main valve body. However, the regulator should not be installed in a tall, vertical pipeline where condensate could collect and create a pressure head affecting regulator performance.
3. Apply steam-compatible pipe compound to the external pipeline threads for a threaded body or use suitable line gaskets for a flanged body. Use acceptable piping procedures when installing regulator.
4. If continuous operation of the system is required during inspection and maintenance, install a three-valve bypass around the regulator. If the flowing medium contains solids, install a properly sized strainer upstream of the regulator.
5. As shown in Figure 3, connect a control line as large as possible but no smaller than 3/8 in. / 9.5 mm diameter bushed down to the 1/4 NPT connection in the cylinder spacer NPS 1, 1-1/2 or 2 / DN 25, 40 or 50 body size or the pilot body NPS 2-1/2, 3, 4 or 6 x 4 / DN 65, 80, 100 or 150 x 100 body size.
6. Locate the control line connection at least 10 pipe diameters away from the regulator or swage and in a section of straight pipe.
7. Do not locate the control line connection in a gate, plug or check valve, in an elbow, swage or other area of the pipeline where turbulence or abnormal velocities may occur or in a large-volume vessel that can cause noticeable control lag.
8. Slope the control line away from the pilot to let condensate drain into the pipeline.
9. Install a shutoff valve (not a needle valve) in the control line to isolate the pilot during maintenance.
10. Install a pressure gauge in the control line or near the regulator, to aid in setting the outlet pressure.
11. With a pressure-loaded or on-off pilot, connect the pressure-loading or on-off piping or tubing to the 1/4 NPT connection in the tapped pilot spring case.
12. The pressure setting of the regulator is determined by:
 - The pilot control spring adjustment on a standard pilot; or

Note

A clogged vent on the spring case of a standard Type 6492H or 6492L pilot may cause the regulator to function improperly. Install and maintain a regulator with a standard pilot so that the spring case vent stays clear.

Type 92S

- The pressure-loading device in conjunction with the control spring adjustment on a pressure-loaded pilot. In both cases, check these settings to make sure they are correct for the application.

Startup and Adjustment

Note

The maximum inlet pressure for a specific construction is stamped on the main valve nameplate. Use pressure gauges to monitor upstream and downstream pressures during startup.

Adjustment

On a regulator with any kind of Type 6492L, 6492H or 6492HT pilot, loosen the hex nut (key 16, Figure 4). Turn the adjusting screw (key 15, Figure 4) clockwise or into the spring case to increase the downstream pressure. Turn the adjusting screw counterclockwise or out of the spring case to decrease the downstream pressure. When the required downstream pressure is maintained for several minutes, tighten the hex nut to lock the adjusting screw in position.

On a regulator with a pressure-loaded Type 6492L, 6492H or 6492HT pilot, also refer to the instruction manual of the pressure-loading device for downstream pressure adjustment procedures. Make sure that the combined pilot control spring setting pressure and spring case loading pressure do not exceed 25 psig / 1.7 bar for the Type 6492L pilot, 150 psig / 10.3 bar for the Type 6492H pilot or 25 psig / 17.2 bar for the Type 6492HT. For example, a 5 psig / 0.34 bar spring setting and a 10 psig / 0.69 bar pressure loading result in a regulator pressure of 15 psig / 1.0 bar.

Safety Override Pilot Startup and Adjustment

1. Loosen adjusting screws of the Type 6492HM or 6492HTM safety override pilot and Type 6492H or 6492HT intermediate pilot on the upstream valve until there is no spring load. The screws should turn freely by hand.
2. Loosen the adjusting screw of the Type 6492H or 6492HT pilot on the downstream valve until there is no spring load.
3. Tighten the Type 6492HM or 6492HTM safety override pilot of the upstream valve all the way in to its highest spring setting.

*Regulator Technologies recommends establishing setpoint by tightening the adjusting screw.

4. Tighten the Type 6492H or 6492HT pilot of the upstream valve all the way in to its highest spring setting.
5. Tighten the Type 6492H or 6492HT pilot of the downstream valve to the desired downstream pressure.
- 6.* Loosen the Type 6492H or 6492HT intermediate pilot on the upstream valve to the desired intermediate pressure (normally 50% of inlet pressure).
7. Loosen the Type 6492HM or 6492HTM safety override pilot of the upstream valve until there is no spring load.
8. Tighten the Type 6492H or 6492HT pilot of the downstream valve all the way in to its highest spring setting.
9. Tighten the Type 6492HM or 6492HTM safety override pilot of the upstream valve to desired pressure as specified per ASME Boiler and Pressure Vessel Code, Section VIII.
- 10.* Loosen the Type 6492H or 6492HT pilot of the downstream valve to the desired downstream pressure setpoint.

Startup with New Regulator Installation

1. Remove all pilot control spring compression by turning the adjusting screw out of the spring case according to the adjustment procedure.
2. Slowly open the upstream block valve.
3. Open the downstream block valve.
4. Open the control line shutoff valve.

Note

Before finally adjusting the pilot setting, allow enough time for the pilot and main valve to heat up and boil off any condensate buildup.

5. If a bypass is used, slowly close the bypass line block valve.
6. Perform the adjustment procedure until the downstream pressure reaches the desired setting.

Startup with Existing Regulator Installation After Normal Shutdown

1. Open the upstream and downstream block valves and let the regulator take over control at the existing pilot control spring setting.
2. If a bypass line is used, slowly control the bypass line block valve.

Shutdown

1. If a bypass line is used, slowly open the bypass line block valve while monitoring the downstream pressure.
2. Close the control line shutoff valve.
3. Close the downstream block valve.
4. Close the upstream block valve.
5. If a pressure-loaded or on-off pilot is used, close the needle valve to the pilot.
6. Vent the regulator and control line to release any trapped pressure.

Maintenance

Regulator parts are subject to normal wear and must be inspected periodically and replaced as necessary. The frequency of inspection and replacement depends upon the severity of service conditions and upon applicable codes and government regulations.



WARNING

To avoid personal injury resulting from sudden release of pressure, isolate the regulator from all pressure and cautiously release trapped pressure from the regulator before attempting disassembly.

Types 6492L, 6492H, 6492HT, 6492HM and 6492HTM Pilots

These procedures are to be performed if inspecting, cleaning or replacing any pilot parts, or if cycling, erratic control or too high or too low an outlet (control) pressure is noted. Perform only those procedures in this section required to correct the problem. Refer to Figure 4 for key numbers unless otherwise noted.

Note

Before performing any maintenance, loosen the hex nut (key 16), if used, and turn the adjusting screw (key 15) or handwheel (key 38) counterclockwise until all compression is removed from the control spring (key 12). Remove the pilot from the pipe nipple and connectors (keys 82 and 83, Figure 6).

1. Unscrew the valve guide (key 2). Remove the screen (key 77), inner valve (key 4), valve spring (key 3) and stem (key 7). Unscrew the seat ring (key 5). Examine the seat ring and plug seating surfaces for damage.
2. Clean and replace parts as necessary. Apply sealant to the seat ring threads. Thread the seat ring into place and tighten it to between 19 and 25 ft-lbs / 26 and 34 N•m of torque.
3. Handle the parts carefully and place the valve spring (key 3) in the valve guide (key 2). Slide the inner valve (key 4) over the spring and into the valve guide. Place the screen (key 77) onto the valve guide. Place the stem (key 7) in the center hole of the valve guide. Apply sealant to the valve guide threads and screw the guide plus attached parts into the body (key 1).
4. Remove the pipe plug (key 74). Then remove the bleed restriction (key 76) on Types 6492L, 6492H and 6492HT or the pipe plug (key 94) on Types 6492HM and 6492HTM. Clean and replace the bleed restriction or pipe plug as necessary.
5. Apply sealant to the threads of the bleed restriction (key 76) or pipe plug (key 94) and install.
6. Apply sealant to the threads of the pipe plug (key 74). Thread the pipe plug into place and tighten using 5 to 15 ft-lbs / 7 to 20 N•m of torque.
7. Remove the cap screws (key 17), spring case (key 14), control spring (key 12) and upper spring seat (key 13) from the body.
8. Remove the lower spring seat (key 11, Types 6492H and 6492HT pilots only) or diaphragm plate assembly (key 24, Type 6492L pilot only), diaphragms (key 10) and diaphragm gasket (key 18) from the body. Inspect and clean the diaphragm gasket and replace if necessary.
9. Unscrew the bellows retainer (key 8) and remove the bellows (key 9). Replace worn parts as necessary, and install the bellows and bellows retainer. Tighten the bellows retainer to between 19 and 25 ft-lbs / 26 and 34 N•m.

Type 92S

10. Install the diaphragm gasket. Install both diaphragms with their raised preformed centers facing toward the spring case.
11. Lubricate the upper spring seat and the exposed threads of the adjusting screw. Install the lower spring seat (key 11, Types 6492H and 6492HT pilots only) or diaphragm plate assembly (key 24, Type 6492L pilot only), control spring (key 12), upper spring seat (key 13) and spring case (key 14). Insert and tighten the cap screws (key 17) to between 12 and 18 ft-lbs / 16 and 24 N•m of torque, using a crisscross bolting pattern.
12. When pilot maintenance is complete, refer to the Startup section to put the regulator back in operation and adjust the pressure setting.

Type 92S Main Valve

Perform these procedures if replacing the piston(s), cylinder(s), stem(s), seals, valve plug or seat ring. All key numbers are referenced in Figure 5 except where otherwise indicated. Instructions are given for complete disassembly and assembly. Disassemble the main valve only as far as necessary to complete the required maintenance. Then, begin the assembly procedure at the appropriate step.

Note

The regulator may remain in the pipeline during maintenance procedures unless the main valve body is replaced or removed for repairs.

Whenever a gasket seal is disturbed by removing or shifting gasketed parts, a new gasket should be installed upon reassembly. This is necessary to ensure a good gasket seal.

Disassembly

1. Disconnect all tubing and remove the pilot from the main valve.
2. Remove the cap screws (key 3, not shown) from a cast iron body or stud nuts (key 4) from a steel body, and lift off the body flange.
3. For NPS 1, 1-1/2 and 2 / DN 25, 40 and 50 body sizes, remove the top cylinder (key 17), and pull out the top piston with attached stem and other parts. Remove the hex nut (key 41), lockwasher (key 40), top ring retainer (key 26) and top piston ring (key 25) from the top piston (key 24).

4. For NPS 1, 1-1/2 and 2 / DN 25, 40 and 50 body sizes, lift off the cylinder spacer (key 21), and remove the stem seal retainer (key 23) and stem seal (key 22) from the spacer.
5. Remove the cylinder (key 17), piston (key 24) with attached parts and spiral wound gasket (key 8).
6. Remove the cotter pin (key 16, NPS 1, 1-1/2 and 2 / DN 25, 40 and 50 body sizes only), stem nut (key 15), lower stem (key 9) with hex head, valve plug (key 6), piston ring retainer (key 26), piston ring (key 25), bottom piston ring retainer (key 26, applicable for all sizes), piston (key 24), spring (key 12), piston spacer (key 11), cage (key 5) and seat ring (key 7).
7. If Noise Attenuation is used, remove the plug spacer (key 33, NPS 2 / DN 50 body size only), deflector (key 36, NPS 2 / DN 50 body size only), and screen (key 37).
8. Either remove the retaining ring (key 14) or remove the spring seat, washer and O-ring (keys 32, 34 and 38), if it is necessary to remove the baffle (key 13).

Assembly

1. Inspect and replace parts as necessary, making sure that the hollow passage in the upper stem (key 20, NPS 1, 1-1/2 and 2 / DN 25, 40 and 50 body sizes only) is free from debris.
2. Install a spiral wound gasket (key 8) into the body (key 1).
3. When installing a new valve plug and/or a new seat ring or lower stem, lap the seating surfaces together outside the body. Use a commercial lapping compound or a mixture of solidified vegetable oil and 600-grit or finer silicon carbide or aluminum oxide.

Note

If a Noise Attenuation is used, install the screen (key 37), the deflector (key 36, NPS 2 / DN 50 body size only) and the plug spacer (key 33, NPS 2 / DN 50 body size only) where appropriate in the following step.

4. Secure the hex head at the lower stem (key 9) in a vise. Install the valve plug (key 6), seat ring (key 7) and cage (key 5).

For NPS 1, 1-1/2 and 2 / DN 25, 40 and 50 body sizes, install the baffle (key 13) and the retaining ring (key 14). Then, install the piston spacer (key 11) down through the baffle until it makes contact with the valve plug.

For NPS 2-1/2, 3 and 4 / DN 65, 80 and 100 body sizes, install the plug spacer (key 33), baffle (key 13), O-ring, washer, spring seat and piston spacer (keys 38, 34, 32 and 11). Then, install the cylinder (key 17), spring (key 12) and secure with piston (key 24), piston ring (key 25), with its open end pointing out, piston ring retainer (key 26) and stem nut (key 15).

For the NPS 1, 1-1/2 and 2 / DN 25, 40 and 50 body sizes, lock the stem nut (key 15) in place with a cotter pin (key 16), but do not fold the pin ends up on top of the stem since this can interfere with loading pressure registration through the top stem passage.

5. Install the main piston cage assembly with attached parts into the body. Coat the edge of the main cylinder (key 17) with sealant and install a new cylinder gasket (key 18) onto this edge.
6. Install a new body gasket (key 19) onto the appropriate edge of the body.
7. For NPS 1, 1-1/2 and 2 / DN 25, 40 and 50 body sizes, install the stem seal (key 22) onto the cylinder spacer (key 21) in the orientation shown in Figure 5, and secure with the stem seal retainer (key 23). Coat the serrated edge of the spacer with sealant and install the spacer edge-side-down over the bottom cylinder.
8. For NPS 1, 1-1/2 and 2 / DN 25, 40 and 50 body sizes, coat both serrated edges of the top cylinder (key 17) with sealant, install new cylinder gaskets (key 18) on these edges and install the cylinder.
9. For NPS 1, 1-1/2 and 2 / DN 25, 40 and 50 body sizes, install the top piston ring (key 25) with its open end pointing out, ring retainer (key 26) and stem (key 20) on the top piston. Secure these parts with the lockwasher and hex nut (keys 40 and 41). Install the top piston plus attached parts stem-first through the stem seal until the top stem contacts the bottom stem.
10. Install the body flange (key 2) on the body, and secure with the cap screws (key 3, not shown) for a cast iron body or with the stud nuts (key 4) for a steel body.
11. Install the pilot and connect all tubing as shown in Figure 6.
12. When all maintenance is complete, refer to the Start-up section to put the regulator back into operation and adjust the pressure setting.

Parts Ordering

The type number, orifice size, spring range and date of manufacture are stamped on the nameplate. Always provide this information in any correspondence with your local Sales Office regarding replacement parts or technical assistance.

When ordering replacement parts, reference the key number of each needed part as found in the following parts list. Separate kit containing all recommended spare parts is available.

Parts List

Types 6492L, 6492H and 6492HT Pilots (Figure 4)

Key	Description	Part Number
	Repair Kits (included are keys 4, 5, 7, 8, 9, 10 and 18)	
	Type 6492L pilot	R6492LX0012
	Types 6492H and 6492HT pilots	R6492HX0012
1	Body	
	Cast iron	
	Type 6492L pilot	32A0404X012
	Type 6492H pilot	22A0403X012
	Steel	
	Type 6492L pilot	32A0404X052
	Types 6492H and 6495HT pilots	22A0403X052
	Stainless steel	
	Type 6492L pilot	32A0404X062
	Types 6492H and 6492HT pilots	22A0403X072
2	Valve Guide, Stainless steel	
	For Cast iron and Steel bodies	1E391835132
	For Stainless steel body	1E391835072
3	Valve Spring, Stainless steel	1E392437022
4*	Inner Valve, Stainless steel	
	For Cast iron and Steel bodies	1F967446172
	For Stainless steel body	1F9674X0012
5*	Orifice, Stainless steel	
	For Cast iron and Steel bodies	1H564446172
	For Stainless steel body	1H5644X0012
7*	Valve Stem, Stainless steel	
	For Cast iron and Steel bodies	1F967835132
	For Stainless steel body	1F9678X0012
8*	Bellows Retainer	
	For Cast iron and Steel bodies, Brass	1F971214012
	For Stainless steel body, Stainless steel	1F9712X0012
9*	Bellows	
	For Cast iron and Steel bodies, Brass	1F971318992
	For Stainless steel body, Stainless steel	1F9713X0012
10*	Diaphragm, Stainless steel (2 required)	
	Type 6492L pilot	ERCA00490A0
	Types 6492H and 6492HT pilots	ERCA00459A0
11	Lower Spring Seat	
	(Types 6492H and 6492HT pilots only)	
	Type 6492H, Aluminum	1J9140X0032
	Type 6492HT, Steel	
	Steel body	1J9140X0022
	Stainless steel body	14B9948X012

*Recommended spare parts

Type 92S

Types 6492L, 6492H and 6492HT Pilots (Figure 4) (continued)

Key	Description	Part Number
12	Control Spring, Plated steel (see Table 1 for outlet pressure ranges)	
	Yellow	1E395627022
	Green	1D7455T0012
	Red	1E395727192
13	Upper Spring Seat, Plated steel Cast iron and Steel bodies Stainless steel body	1D667125072 14B9951X012
14	Spring Case	
	Standard Cast iron	
	Type 6492L pilot	3J496319012
	Type 6492H pilot	2J496219012
	Tapped Cast iron	
	Type 6492L pilot	3L442119012
	Type 6492H pilot	2L441919012
	Standard Steel	
	Type 6492L pilot	3L416122012
	Types 6492H and 6492HT pilots	2L416322012
	Tapped Steel	
	Type 6492L pilot	3L442222012
	Types 6492H and 6492HT pilots	2L442022012
	Standard Stainless steel	
	Type 6492L pilot	3L4161X0022
	Types 6492H and 6492HT pilots	2L416333092
	Tapped Stainless steel	
	Type 6492L pilot	3L4422X0012
	Types 6492H and 6492HT pilots	2L4420X0012
15	Adjusting Screw (standard spring case only), Zinc-plated steel	
	Standard	1D995448702
	Handwheel	1J496428982
16	Hex Nut (standard spring case only), Zinc-plated steel	1A353724122
17	Cap Screw, Steel, Plate (10 required for Type 6492L pilot and 8 required for Types 6492H and 6492HT pilots)	
	Type 6492L	
	Cast iron and Steel bodies	1A381624052
	Stainless steel	1A3816X0152
	Type 6492H	
	Cast iron and Steel bodies	1A381624052
	Stainless steel	1A3816X0152
	Type 6492HT	
	Steel	1A3816X0242
	Stainless steel	1A3816X0152
18*	Diaphragm Gasket	
	Type 6492L pilot	1E3970X0012
	Type 6492H or 6492HT, Graphite	ERCA00485A1
24	Diaphragm Plate Assembly, Aluminum/Steel/ Stainless steel (Type 6492L pilot only)	1E3967X0012
74	Pipe Plug, Steel	0Z020128992
76	Bleed Restriction, Stainless steel	19A2612X012
77	Screen, Stainless steel	16A1512X012
78	Reducing Bushing, Cast iron and Steel bodies, steel Stainless steel body, Stainless steel	1C379026232 1C3790X0012
87	Sealing Washer, Carbon steel (tapped spring case only)	1V205699012

Types 6492HM and 6492HTM Safety Override Pilots (Figure 4)

Key	Description	Part Number
1	Pilot Valve Body Steel	22A0403X052
	Stainless steel	22A0403X072
2	Valve Guide Steel	1E391835132
	Stainless steel	1E391835072
3	Valve Spring, Stainless steel	1E392437022
4	Inner Valve Steel	1F967446172
	Stainless steel	1F9674X0012
5	Orifice Steel	1H564446172
	Stainless steel	1H5644X0012
7	Valve Stem Steel	1F967835132
	Stainless steel	1F9678X0012
8	Bellows Retainer Steel	1F971214012
	Stainless steel	1F9712X0012
9	Bellows Steel	1F971318992
	Stainless steel	1F9713X0012
10	Diaphragm, Stainless steel (2 required)	ERCA00459A0
11	Lower Spring Seat, Aluminum Type 6492HM Type 6492HTM Steel	1J9140X0032
	Stainless steel	1J9140X0022
12	Spring Type 6492HM, Steel	1E395627022
	10 to 30 psig / 0.69 to 2.1 bar, Yellow	1D7455T0012
	25 to 75 psig / 1.72 to 5.2 bar, Green	1E395727192
	70 to 150 psig / 4.8 to 10.3 bar, Red	
	Type 6492HTM, Stainless steel	
	15 to 100 psig / 1.0 to 6.9 bar, Unpainted	14B9943X012
	80 to 250 psig / 5.5 to 17.2 bar, Unpainted	14B9942X022
13	Upper Spring Seat Type 6492HM, Zinc-plated steel Type 6492HTM, Carbon-plated steel	1D667125072 14B9951X012
14	Spring Case Steel	
	With standard adjusting screw	2L416322012
	With sealed adjusting screw	2L442022012
	Stainless steel	
	With standard adjusting screw	2L416333092
	With sealed adjusting screw	2L4420X0012
15	Set Screw, Zinc-plated steel Standard Handwheel Sealed Adjusting screw	1D995448702 1J496428982 1D995448702
16	Hex Nut, Zinc-plated steel	1A353724122
17	Cap Screw (8 required) Type 6492HM Steel	1A381624052
	Stainless steel	1A3816X0152
	Type 6492HTM Steel	1A3816X0242
	Stainless steel	1A3816X0152
18*	Diaphragm Gasket Graphite	ERCA00485A1
34	Machine Screw for use with Handwheel, Carbon-plated steel	16A5763X012

*Recommended spare parts

Types 6492HM and 6492HTM Safety Override Pilots (Figure 4) (continued)

Key	Description	Part Number
38	Handwheel	1J496144012
39	Lock Washer for use with Handwheel, Alloy steel	1A352332992
74	Pipe Plug	
	Steel	0Z020128992
	Stainless steel	0Z020135072
77	Screen, Stainless steel	16A1512X012
78	Reducing Bushing	
	Steel	1C379026232
	Stainless steel	1C3790X0012
87	Sealed Adjusting Screw Sealing Washer	1V205699012
94	Pipe Plug, Stainless steel	1E823135042
95	Warning Label	19B0429X0A2

Types 6492HM and 6492HTM Safety Pilot Mounting Parts (Figure 6)

Key	Description	Part Number
81	Tubing, Stainless steel (2 required)	-----
82	Pipe Nipple	
	NPS 1, 1-1/2 or 2 / DN 25, 40 or 50 body size	
	Steel	-----
	Stainless steel	-----
	NPS 2-1/2 / DN 65 body size	
	Steel	-----
	Stainless steel	-----
	NPS 3 / DN 80 body size	
	Steel	-----
	Stainless steel	-----
	NPS 4 or 4 x 6 / DN 100 or 100 x 150 body size	
	Steel	-----
	Stainless steel	-----
83	Connector (2 required)	
	Steel	-----
	Stainless steel	-----
84	Elbow (2 required)	
	Steel	-----
	Stainless steel	-----
86	Pipe Elbow for Stainless steel (2 required)	-----
89	Pipe Nipple (2 required)	
	Steel	-----
	Stainless steel	-----
90	Pipe Nipple	
	NPS 1 / DN 25 body size	
	Steel	-----
	Stainless steel	-----
	NPS 1-1/2 / DN 40 body size	
	Steel	-----
	Stainless steel	-----
	NPS 2 / DN 50 body size	
	Steel	-----
	Stainless steel	-----
	NPS 2-1/2, 3 or 4 / DN 65, 80 or 100 body size	
	Steel	-----
	Stainless steel	-----
	NPS 4 x 6 / DN 100 x 150 body size	
	Steel	-----
	Stainless steel	-----
92	Pipe Adapter for NPS 1, 1-1/2 and 2 / DN 25, 40 and 50 body sizes	
	Steel	-----
	Stainless steel	-----
93	Pipe Elbow for steel bodies, Carbon-plated steel (2 required)	-----

*Recommended spare parts

Type 92S Main Valve (Figure 5)

Key	Description	Part Number
	Repair Kits (included are keys 8, 16, 18, 19, 25 and 38)	
	NPS 1 / DN 25 body	R92SX000052
	NPS 1-1/2 / DN 40 body	R92SX000062
	NPS 2 / DN 50 body	R92SX000072
	NPS 2-1/2 / DN 65 body	R92EX0000B2
	NPS 3 / DN 80 body	R92EX000032
	NPS 4 or 6 x 4 / DN 100 or 150 x 100 body	R92EX000042
1	Body	See following table
2	Body Flange	
	Cast iron	
	NPS 1 / DN 25 body	26A7837X012
	NPS 1-1/2 / DN 40 body	26A7900X012
	NPS 2 / DN 50 body	26A7869X012
	NPS 2-1/2 / DN 65 body	27A1548X012
	NPS 3 / DN 80 body	27A1576X012
	NPS 4 or 6 x 4 / DN 100 or 150 x 100 body	27A1600X012
	WCC steel	
	NPS 1 / DN 25 body	26A7838X012
	NPS 1-1/2 / DN 40 body	26A7901X012
	NPS 2 / DN 50 body	26A7870X012
	NPS 2-1/2 / DN 65 body	27A1549X012
	NPS 3 / DN 80 body	27A1577X012
	NPS 4 or 6 x 4 / DN 100 or 150 x 100 body	27A1601X012
	CF8M Stainless steel	
	NPS 1 / DN 25 body	26A7838X032
	NPS 1-1/2 / DN 40 body	26A7901X032
	NPS 2 / DN 50 body	26A7870X032
	NPS 2-1/2 / DN 65 body	27A1549X022
	NPS 3 / DN 80 body	27A1577X042
	NPS 4 or 6 x 4 / DN 100 or 150 x 100 body	27A1601X022
3	Cap Screw (not shown), Zinc-plated steel	
	For Cast iron body	
	NPS 1 / DN 25 body (4 required)	16A7839X012
	NPS 1-1/2 or 2 / DN 40 or 50 body (8 required)	1U625631192
	NPS 2-1/2 / DN 65 body (8 required)	1R281124052
	NPS 3 / DN 80 body (8 required)	1A454124052
	NPS 4 or 6 x 4 / DN 100 or 150 x 100 body (8 required)	1A440224052
3	Stud Bolt, Steel	
	For Steel body	
	NPS 1 / DN 25 body (4 required)	1V5426X0052
	NPS 1-1/2 or 2 / DN 40 or 50 body (8 required)	16A7902X032
	NPS 2-1/2 / DN 65 body (8 required)	1R2848X0752
	NPS 3 / DN 80 body (8 required)	1A3781X0562
	NPS 4 or 6 x 4 / DN 100 or 150 x 100 body (8 required)	1R3690X0592
	For Stainless steel body	
	NPS 1 / DN 25 body (4 required)	1V5426X0032
	NPS 1-1/2 or 2 / DN 40 or 50 body (8 required)	16A7902X022
	NPS 2-1/2 / DN 65 body (8 required)	1R284835222
	NPS 3 / DN 80 body (8 required)	1A3781X0042
	NPS 4 or 6 x 4 / DN 100 or 150 x 100 body (8 required)	1R3690X001
4	Stud Nut, Steel	
	For steel body	
	NPS 1 / DN 25 body (4 required)	1C3306X0832
	NPS 1-1/2 or 2 / DN 40 or 50 body (8 required)	1A3772X0892
	NPS 2-1/2 / DN 65 body (8 required)	1C3306X0832
	NPS 3 / DN 80 body (8 required)	1A3760X0832
	NPS 4 or 6 x 4 / DN 100 or 150 x 100 body (8 required)	1A3520X0922
	For Stainless steel body	
	NPS 1 / DN 25 body (4 required)	1C330635252
	NPS 1-1/2 or 2 / DN 40 or 50 body (8 required)	1A3772X0012
	NPS 2-1/2 / DN 65 body (8 required)	1C330635252
	NPS 3 / DN 80 body (8 required)	1A3760X0012
	NPS 4 or 6 x 4 / DN 100 or 150 x 100 body (8 required)	1A352035252

Type 92S

Type 92S Main Valve (Figure 5) (continued)

Key	Description	Part Number	Key	Description	Part Number
5	Cage Cast iron NPS 1 / DN 25 body NPS 1-1/2 / DN 40 body NPS 2 / DN 50 body NPS 2-1/2 / DN 65 body NPS 3 / DN 80 body NPS 4 or 6 x 4 / DN 100 or 150 x 100 body Stainless steel NPS 1 / DN 25 body NPS 1-1/2 / DN 40 body NPS 2 / DN 50 body NPS 2-1/2 / DN 65 body NPS 3 / DN 80 body NPS 4 or 6 x 4 / DN 100 or 150 x 100 body	29A1379X012 26A7903X012 26A7872X012 27A1550X012 27A1578X012 27A1602X012 29A1379X022 26A7903X022 26A7872X022 27A1550X022 27A1578X022 27A1602X022	12	Spring, Stainless steel NPS 1 / DN 25 body NPS 1-1/2 / DN 40 body NPS 2 / DN 50 body NPS 2-1/2 / DN 65 body NPS 3 / DN 80 body NPS 4 or 6 x 4 / DN 100 or 150 x 100 body	16A7849X012 16A7911X012 16A7880X012 17A1559X012 17A1586X012 17A1611X012
6	Valve Plug, Stainless steel NPS 1 / DN 25 body NPS 1-1/2 / DN 40 body NPS 2 / DN 50 body NPS 2-1/2 / DN 65 body NPS 3 / DN 80 body NPS 4 or 6 x 4 / DN 100 or 150 x 100 body	16A7842X012 16A7904X012 16A7873X012 27A1552X012 27A1580X012 27A1604X012	13	Baffle, Stainless steel NPS 1 / DN 25 body NPS 1-1/2 / DN 40 body NPS 2 / DN 50 body NPS 2-1/2 / DN 65 body NPS 3 / DN 80 body NPS 4 or 6 x 4 / DN 100 or 150 x 100 body	19A1378X012 16A7912X012 16A7881X012 17A1560X012 17A1587X012 17A1612X012
7	Seat Ring, Stainless steel NPS 1 / DN 25 body NPS 1-1/2 / DN 40 body NPS 2 / DN 50 body NPS 2-1/2 / DN 65 body NPS 3 / DN 80 body NPS 4 / DN 100 body NPS 6 x 4 / 150 x 100 body	16A7844X012 16A7906X012 16A7875X012 27A1553X012 27A1581X012 27A1605X012 27A9678X012	14	Retaining Ring For Cast iron and Steel bodies, Steel NPS 1 / DN 25 body NPS 1-1/2 / DN 40 body NPS 2 / DN 50 body For Stainless steel body, Stainless steel NPS 1 / DN 25 body NPS 1-1/2 / DN 40 body NPS 2 / DN 50 body	16A7851X012 16A7913X012 16A7882X012 16A7851X022 16A7913X022 16A7882X022
8*	Spiral Wound Gasket, Stainless steel and Graphite NPS 1 / DN 25 body NPS 1-1/2 / DN 40 body NPS 2 / DN 50 body NPS 2-1/2 / DN 65 body NPS 3 / DN 80 body NPS 4 or 6 x 4 / DN 100 or 150 x 100 body	16A7845X012 16A7907X012 16A7876X012 17A1554X012 17A1582X012 17A1606X012	15	Stem Nut For Cast iron and Steel bodies, Zinc-plated steel NPS 1 / DN 25 body NPS 1-1/2 or 2 / DN 40 or 50 body NPS 2-1/2 or 3 / DN 65 or 80 body NPS 4 or 6 x 4 / DN 100 or 150 x 100 body For Stainless steel body, Stainless steel NPS 1 / DN 25 body NPS 1-1/2 or 2 / DN 40 or 50 body NPS 2-1/2 or 3 / DN 65 or 80 body NPS 4 or 6 x 4 / DN 100 or 150 x 100 body	16A7852X012 16A7914X012 1A413224122 1A420124122 16A7852X022 16A7914X022 1A413235252 1A4201X0012
9	Lower Stem, Zinc-plated steel For Cast iron and Steel bodies, Zinc-plated steel NPS 1 / DN 25 body NPS 1-1/2 / DN 40 body NPS 2 / DN 50 body NPS 2-1/2 / DN 65 body NPS 3 / DN 80 body NPS 4 or 6 x 4 / DN 100 or 150 x 100 body For Stainless steel body, NPS 1 / DN 25 body NPS 1-1/2 / DN 40 body NPS 2 / DN 50 body NPS 2-1/2 / DN 65 body NPS 3 / DN 80 body NPS 4 or 6 x 4 / DN 100 or 150 x 100 body	16A7846X012 16A7908X012 16A7877X012 17A1556X012 17A1584X012 17A1608X012 16A7846X022 16A7908X022 16A7877X022 17A1556X022 17A1584X022 17A1608X022	16	Cotter Pin, Stainless steel NPS 1 / DN 25 body NPS 1-1/2 or 2 / DN 40 or 50 body	16A7930X012 17A5574X012
11	Piston Spacer, Steel NPS 1 / DN 25 body NPS 1-1/2 / DN 40 body NPS 2 / DN 50 body For Standard trim For Noise Attenuation NPS 2-1/2 / DN 65 body NPS 3 / DN 80 body NPS 4 or 6 x 4 / DN 100 or 150 x 100 body	16A7848X012 16A7910X012 16A7879X012 17A6562X012 17A1558X012 17A1585X012 17A1610X012	17	Cylinder, Stainless steel For Cast iron and Steel bodies, Zinc-plated steel NPS 1 / DN 25 body (2 required) NPS 1-1/2 / DN 40 body (2 required) NPS 2 / DN 50 body (2 required) NPS 2-1/2 / DN 65 body (1 required) NPS 3 / DN 80 body (1 required) NPS 4 or 6 x 4 / DN 100 or 150 x 100 body (1 required) For Stainless steel body, Stainless steel NPS 1 / DN 25 body (2 required) NPS 1-1/2 / DN 40 body (2 required) NPS 2 / DN 50 body (2 required) NPS 2-1/2 / DN 65 body (1 required) NPS 3 / DN 80 body (1 required) NPS 4 or 6 x 4 / DN 100 or 150 x 100 body (1 required)	16A7853X012 16A7915X012 16A7884X012 17A1561X012 17A1588X012 17A1613X012 16A7853X022 16A7915X022 16A7884X022 17A1561X022 17A1588X022 17A1613X022
			18*	Cylinder Gasket For Cast iron and Steel bodies, Copper NPS 1 / DN 25 body (3 required) NPS 1-1/2 / DN 40 body (3 required) NPS 2 / DN 50 body (3 required) NPS 2-1/2 / DN 65 body (1 required) NPS 3 / DN 80 body (1 required) NPS 4 or 6 x 4 / DN 100 or 150 x 100 body (1 required) For Stainless steel body, N04400 Nickel Alloy NPS 1 / DN 25 body (3 required) NPS 1-1/2 / DN 40 body (3 required) NPS 2 / DN 50 body (3 required) NPS 2-1/2 / DN 65 body (1 required) NPS 3 / DN 80 body (1 required) NPS 4 or 6 x 4 / DN 100 or 150 x 100 body (1 required)	16A7854X012 16A7916X012 16A7885X012 14A5685X022 17A1589X012 17A1614X012 16A7854X022 16A7916X032 16A7885X032 14A5685X062 17A1589X022 17A1614X022

*Recommended spare parts

Type 92S Main Valve (Figure 5) (continued)

Key	Description	Part Number
19*	Body Gasket For Cast iron and Steel bodies, Copper NPS 1 / DN 25 body NPS 1-1/2 / DN 40 body NPS 2 / DN 50 body NPS 2-1/2 / DN 65 body NPS 3 / DN 80 body NPS 4 or 6 x 4 / DN 100 or 150 x 100 body For Stainless steel body, N04400 Nickel Alloy NPS 1 / DN 25 body NPS 1-1/2 / DN 40 body NPS 2 / DN 50 body NPS 2-1/2 / DN 65 body NPS 3 / DN 80 body NPS 4 or 6 x 4 / DN 100 or 150 x 100 body	14A6785X022 14A3384X022 14A5685X022 17A1563X012 13A0354X022 14A5650X022 14A6785X042 14A3384X042 14A5685X062 17A1563X022 13A0354X032 14A5650X052
20	Upper Stem, Stainless steel NPS 1 / DN 25 body NPS 1-1/2 or 2 / DN 40 or 50 body	16A7855X012 16A7886X012
21	Cylinder Spacer, Steel NPS 1 / DN 25 body NPS 1-1/2 / DN 40 body NPS 2 / DN 50 body	26A7856X012 26A7918X012 26A7887X012
22*	Stem Seal, Polytetrafluoroethylene (PTFE) NPS 1 / DN 25 body NPS 1-1/2 or 2 / DN 40 or 50 body	16A7962X012 16A7963X012
23	Stem Seal Retainer, Stainless steel NPS 1 / DN 25 body NPS 1-1/2 or 2 / DN 40 or 50 body	16A7857X012 16A7888X012
24	Piston, Stainless steel For Cast iron and Steel bodies, NPS 1 / DN 25 body (2 required) NPS 1-1/2 / DN 40 body (2 required) NPS 2 / DN 50 body (2 required) NPS 2-1/2 / DN 65 body (1 required) NPS 3 / DN 80 body (1 required) NPS 4 or 6 x 4 / DN 100 or 150 x 100 body (1 required) For Stainless steel body, Stainless steel NPS 1 / DN 25 body (2 required) NPS 1-1/2 / DN 40 body (2 required) NPS 2 / DN 50 body (2 required) NPS 2-1/2 / DN 65 body (1 required) NPS 3 / DN 80 body (1 required) NPS 4 or 6 x 4 / DN 100 or 150 x 100 body (1 required)	19A6005X012 19A6006X012 19A6007X012 17A1564X012 17A1590X012 17A1615X012 19A6005X022 19A6006X022 19A6007X022 17A1564X022 17A1590X022 17A1615X022
25*	Piston Ring, Stainless steel/PTFE NPS 1 / DN 25 body (2 required) NPS 1-1/2 / DN 40 body (2 required) NPS 2 / DN 50 body (2 required) NPS 2-1/2 / DN 65 body (1 required) NPS 3 / DN 80 body (1 required) NPS 4 or 6 x 4 / DN 100 or 150 x 100 body (1 required)	19A6010X012 19A6011X012 19A6012X012 17A1565X012 17A1591X012 17A1616X012
26	Ring Retainer, Stainless steel NPS 1 / DN 25 body (2 required) NPS 1-1/2 / DN 40 body (2 required) NPS 2 / DN 50 body (2 required) NPS 2-1/2 / DN 65 body (1 required) NPS 3 / DN 80 body (1 required) NPS 4 or 6 x 4 / DN 100 or 150 x 100 body (1 required)	16A7860X012 16A7922X012 16A7891X012 17A1566X012 17A1592X012 17A1617X012
29	Flow Arrow, Stainless steel NPS 1 / DN 25 body NPS 1-1/2, 2, 2-1/2, 3, 4 or 6 x 4 / DN 40, 50, 65, 80, 100 or 150 x 100 body	1V105938982 1V106038982

Type 92S Main Valve (Figure 5) (continued)

Key	Description	Part Number
32	Spring Seat For Cast iron and Steel bodies, Steel NPS 2-1/2 / DN 65 body NPS 3 / DN 80 body NPS 4 or 6 x 4 / DN 100 or 150 x 100 body For Stainless steel, Stainless steel NPS 2-1/2 / DN 65 body NPS 3 / DN 80 body NPS 4 or 6 x 4 / DN 100 or 150 x 100 body	17A1567X012 17A1593X012 17A1618X012 17A1567X022 17A1593X022 17A1618X022
33	Plug Spacer, Stainless steel NPS 2 size (Noise Attenuation only) NPS 2-1/2 / DN 65 body NPS 3 / DN 80 body NPS 4 or 6 x 4 / DN 100 or 150 x 100 body	17A6563X012 17A1568X012 17A1594X012 17A1619X012
34	Washer For Cast iron and Steel bodies, Steel NPS 2-1/2 or 3 / DN 65 or 80 body NPS 4 or 6 x 4 / DN 100 or 150 x 100 body For Stainless steel body, Stainless steel NPS 2-1/2 or 3 / DN 65 or 80 body NPS 4 or 6 x 4 / DN 100 or 150 x 100 body	17A1569X012 17A1620X012 17A1569X022 17A1620X022
35	Groove Pin, Stainless steel NPS 2-1/2 / DN 65 or larger body	1C8989X0012
36	Deflector, Stainless steel (2 Noise Attenuation only)	17A6561X012
37	Screen, Stainless steel (Noise Attenuation only) NPS 2 / DN 50 body NPS 2-1/2 / DN 65 body NPS 3 / DN 80 body NPS 4 or 6 x 4 / DN 100 or 150 x 100 body	17A5751X012 17A7760X012 17A7761X012 17A7762X012
38*	O-ring, PTFE NPS 2-1/2 or 3 / DN 65 or 80 body NPS 4 or 6 x 4 / DN 100 or 150 x 100 body	17A7396X012 17A7397X012
40	Lockwasher, Stainless steel NPS 1 / DN 25 body NPS 1-1/2 or 2 / DN 40 or 50 body	1F128035022 1A505638992
41	Hex Nut NPS 1 / DN 25 body, Stainless steel NPS 1-1/2 or 2 / DN 40 or 50 body, Plated steel	1A391535252 1A346524122

Pilot Mounting Parts (Figure 6)

Key	Description	Part Number
81	Loading Tubing, Copper	-----
82	Pipe Nipple, Steel	-----
83	Connector, Brass	-----
84	Elbow, Brass (2 required for NPS 1, 1-1/2 or 2 / DN 25, 40 or 50 body size and 1 required for larger sizes)	-----
85	Inlet Tubing, Copper (For NPS 1, 1-1/2 or 2 / DN 25, 40 or 50)	-----
86	Street Elbow	-----
89	Pipe Nipple (2 required)	-----
90	Pipe Nipple	-----
93	Pipe Elbow	-----

*Recommended spare parts

Type 92S

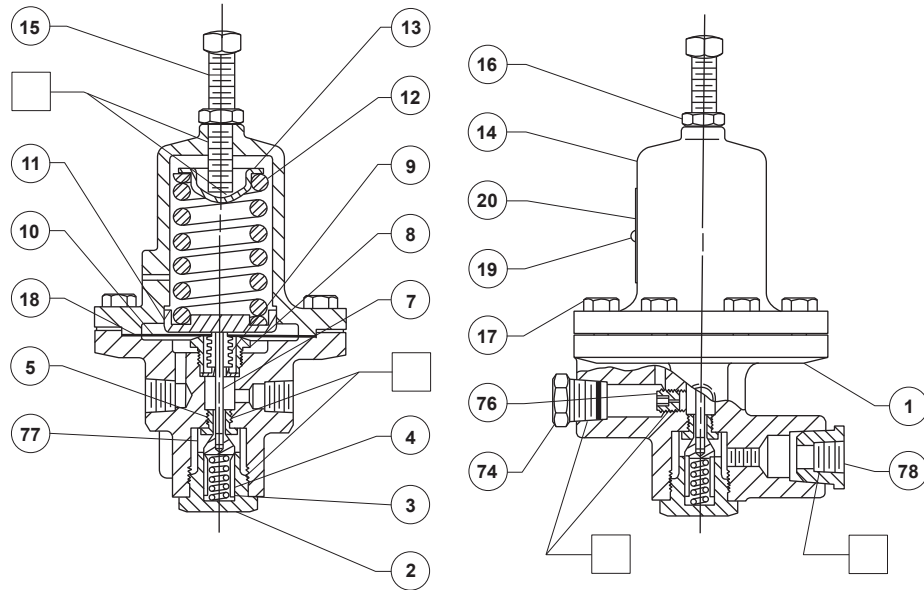

39A3514-B

TYPE 6492H OR 6492HT PILOT

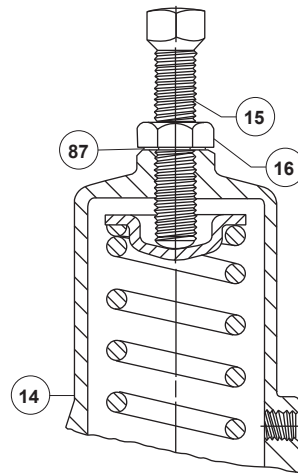

32A4712-A

DETAIL OF TAPPED SPRING CASE WITH SEALED ADJUSTING SCREW

□ APPLY LUBRICANT/SEALANT/ADHESIVE

Figure 4. Pilot Assemblies

Key 1, Body

BODY MATERIAL	END CONNECTION STYLE	BODY SIZE, NPS / DN						
		1 / 25	1-1/2 / 40	2 / 50	2-1/2 / 65	3 / 80	4 / 100	6 x 4 / 150 x 100
Cast Iron	NPT	GE11518X012	26A7893X012	GE10583X012	-----	-----	-----	-----
	CL125 FF	GE11528X012	26A7894X012	GE10585X012	37A1543X012	37A1571X012	GE10707X012	-----
	CL250 RF	GE11580X012	26A7895X012	GE10587X012	37A1544X012	37A1572X012	GE10822X012	-----
WCC Steel	NPT	GE11581X012	26A7896X012	GE10588X012	-----	-----	-----	-----
	CL150 RF	GE11583X012	26A7897X012	GE10676X012	37A1545X012	37A1573X012	GE10835X012	-----
	CL300 RF	GE11607X012	26A7898X012	GE10678X012	37A1546X012	37A1574X012	GE10839X012	37A9679X012
	CL600 RF	GE11608X012	26A7899X012	GE10679X012	37A1547X012	37A1575X012	GE10842X012	37A9680X022
CF8M SST	NPT	GE11581X022	26A7896X032	GE10588X022	-----	-----	-----	-----
	CL150 RF	GE11583X022	26A7897X032	GE10676X022	37A1545X032	37A1573X032	GE10835X022	-----
	CL300 RF	GE11607X022	26A7898X052	GE10678X022	37A1546X022	37A1574X052	GE10839X022	37A9679X022
	CL600 RF	GE11608X022	26A7899X022	GE10679X022	37A1547X022	37A1575X022	GE10842X022	37A9680X022

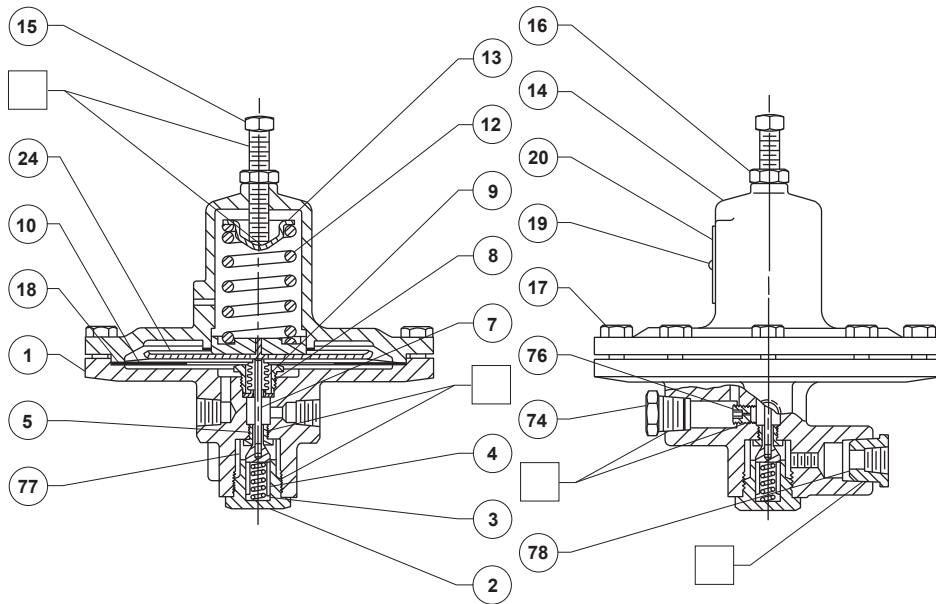

39A3515-B

TYPE 6492L PILOT

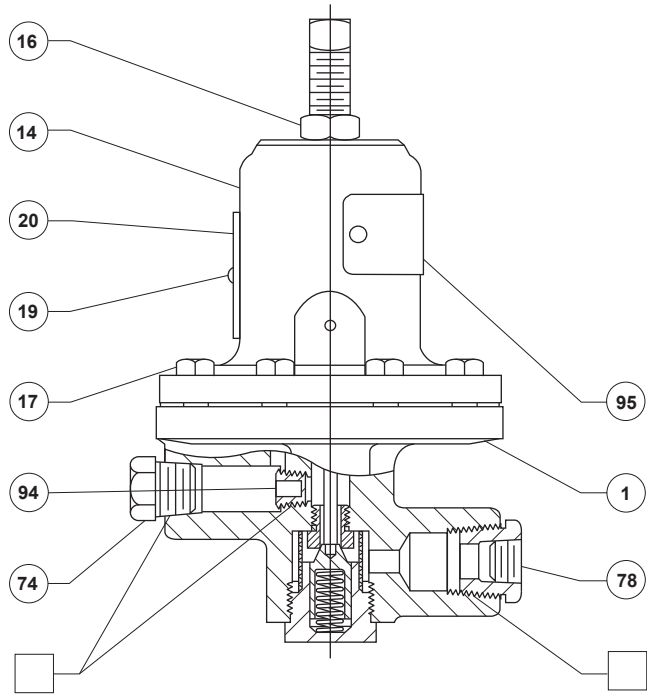
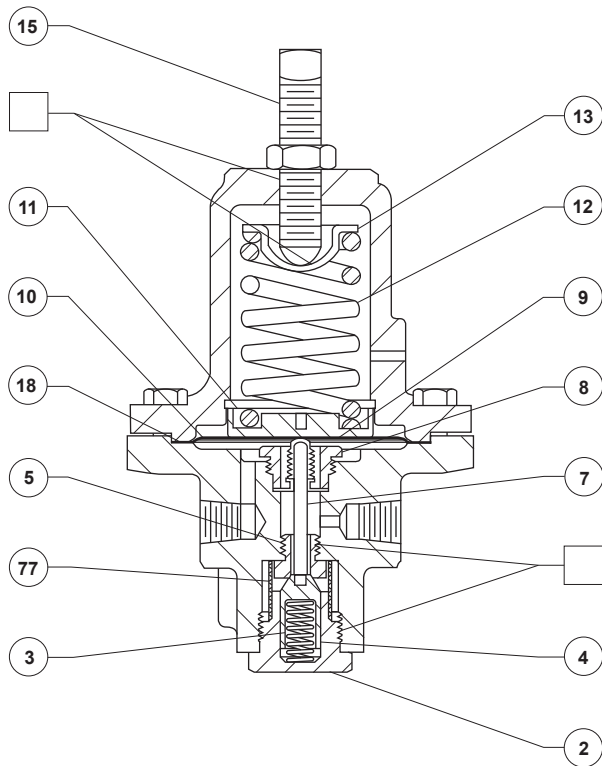

TYPE 6492HM PILOT

39B3357_A

□ APPLY LUBRICANT/SEALANT/ADHESIVE

Figure 4. Pilot Assemblies (continued)

Type 92S

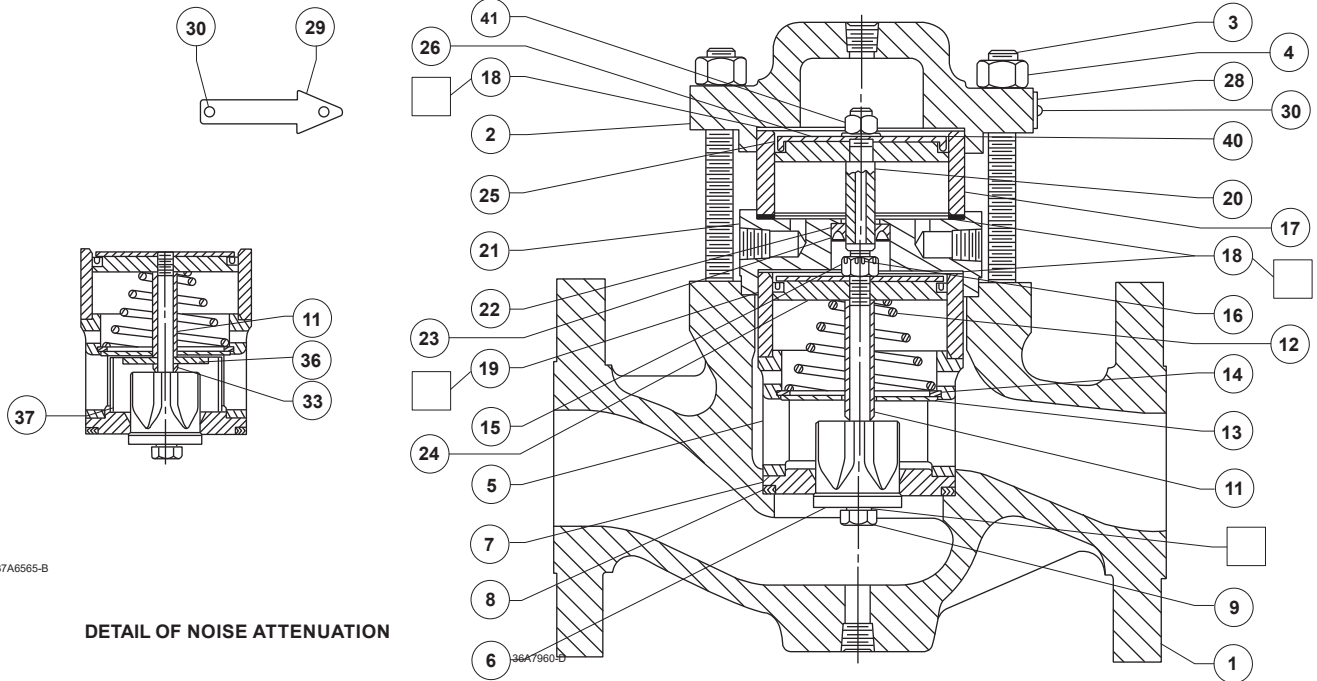

37A6565-B

DETAIL OF NOISE ATTENUATION

NPS 1, 1-1/2 OR 2 / DN 25, 40 OR 50 BODY SIZE

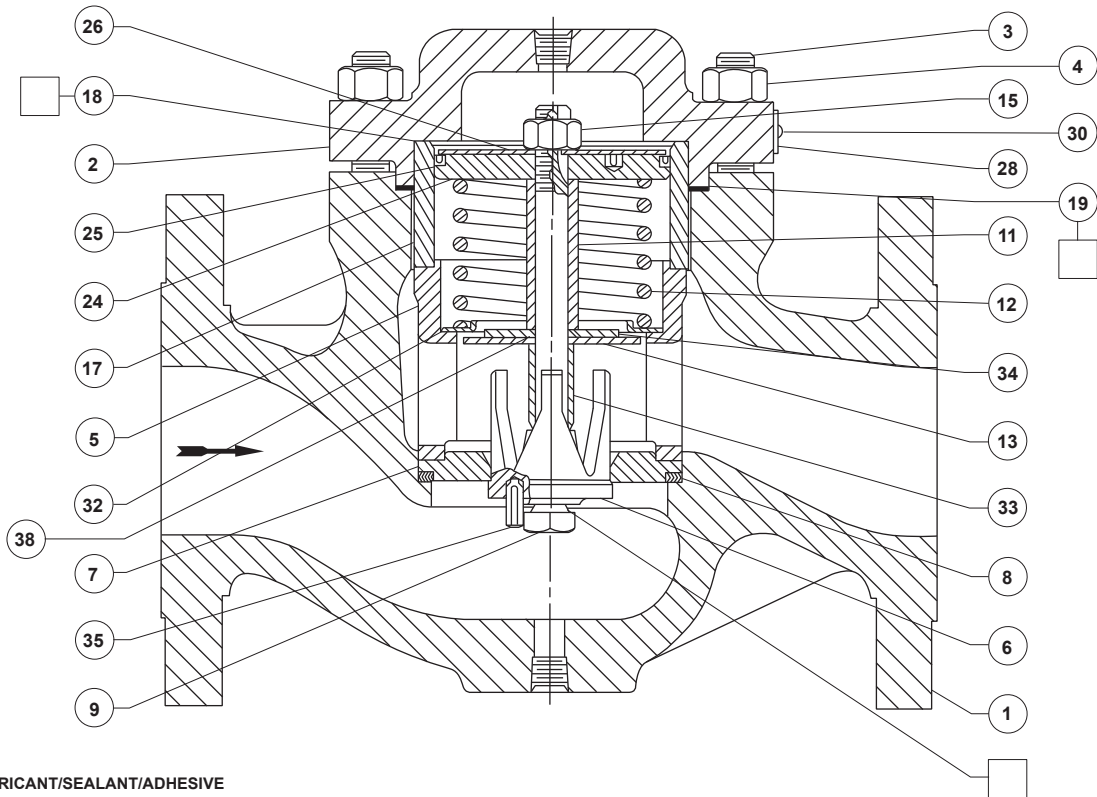

37A1622-D

□ APPLY LUBRICANT/SEALANT/ADHESIVE

NPS 2-1/2, 3, 4 OR 6 X 4 / DN 65, 80, 100 OR 150 X 100 BODY SIZE

Figure 5. Type 92S Main Valve Assemblies

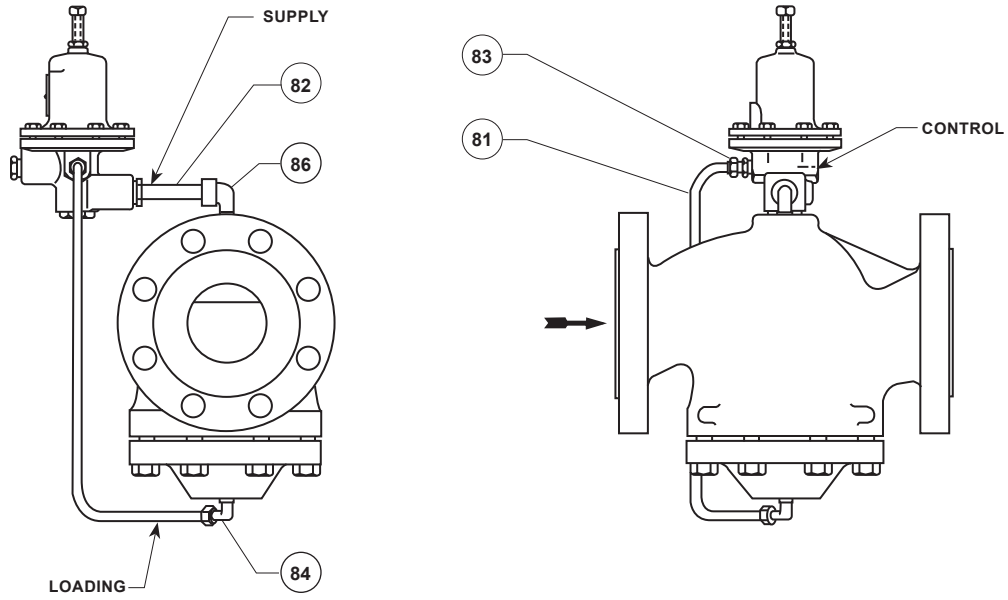

39A3519-C

WITH PILOT MOUNTED IN STANDARD POSITION SO CONTROL LINE CONNECTION FACES DOWNSTREAM

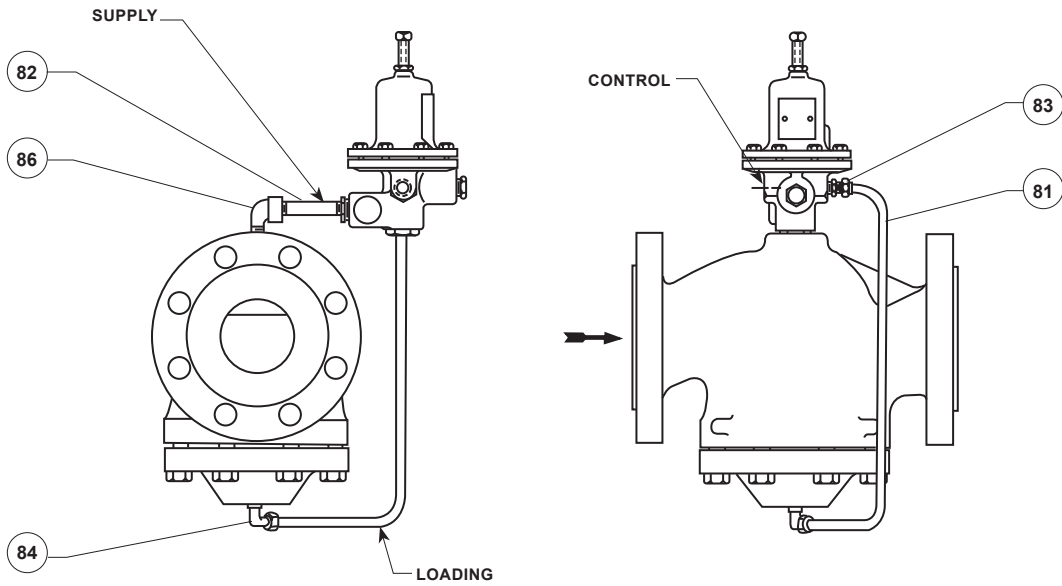

30B3840_A

WITH PILOT MOUNTED IN OPTIONAL POSITION SO CONTROL LINE CONNECTION FACES UPSTREAM

NPS 2-1/2, 3, 4 OR 6 X 4 / DN 65, 80 100 OR 150 X 100 BODY SIZE

Figure 6. Pilot Mounting Parts

Type 92S

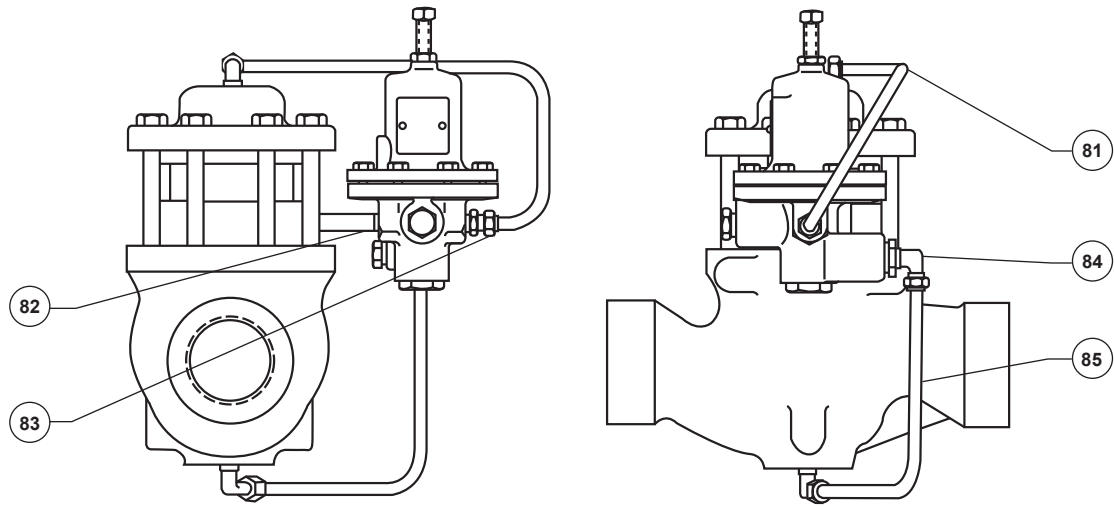

29A3518-B

NPS 1, 1-1/2 OR 2 / DN 25, 40 OR 50 BODY SIZE

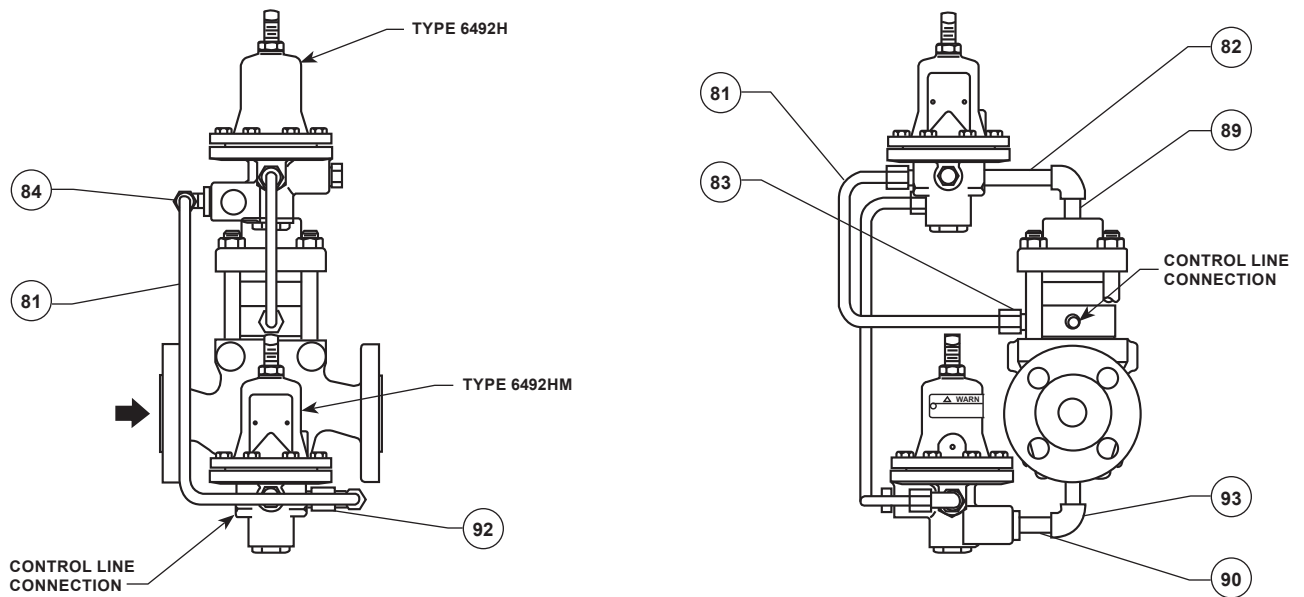

49B1169_A

NPS 1, 1-1/2 AND 2 / DN 25, 40 AND 50 BODY SIZES WITH TYPE 6492HM PILOT MOUNTING PARTS

Figure 6. Pilot Mounting Parts (continued)

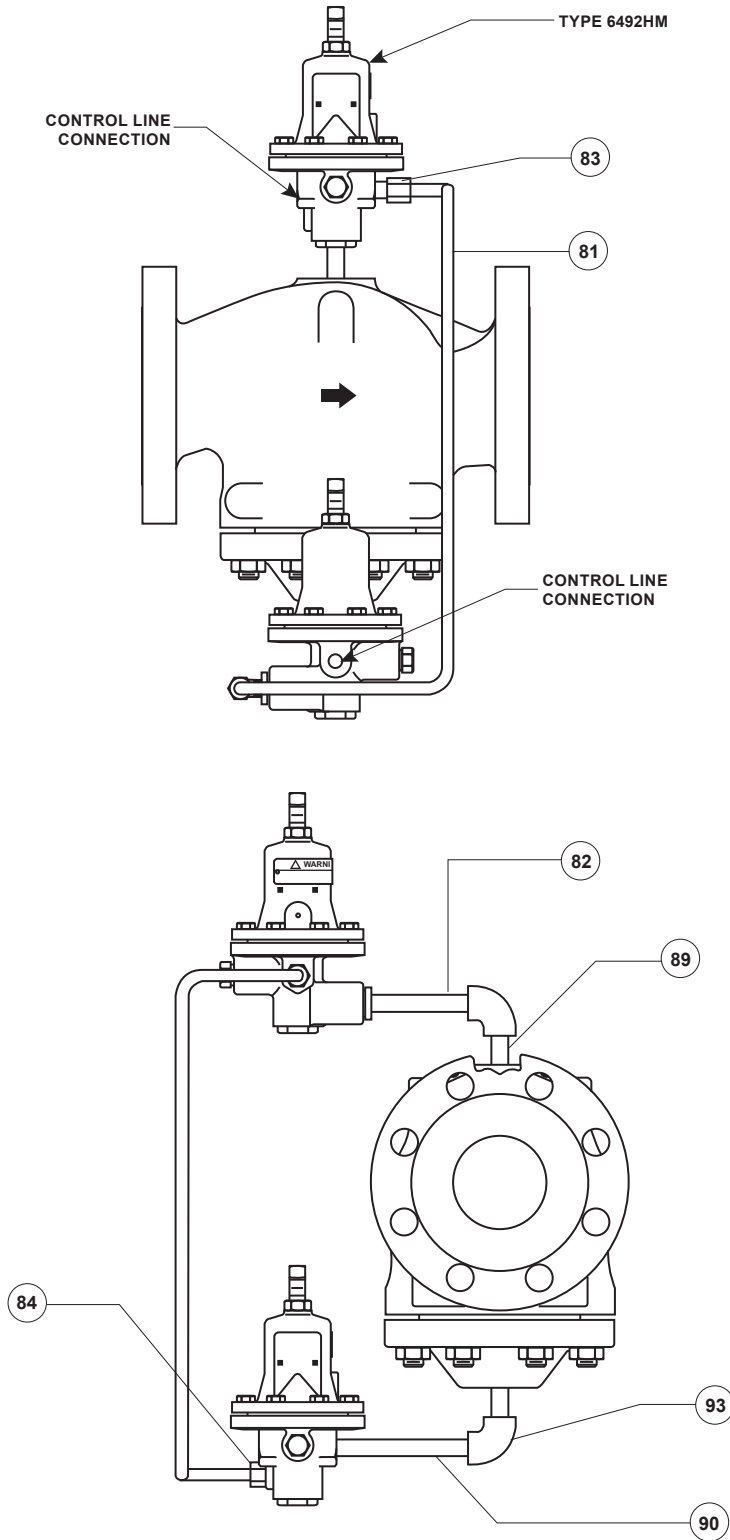

49B1170_A

NPS 2-1/2, 3 AND 4 / DN 65, 80 AND 100 BODY SIZES WITH TYPE 6492HM PILOT MOUNTING PARTS

Figure 6. Pilot Mounting Parts (continued)

Type 92S

✉ Webadmin.Regulators@emerson.com

🔍 Fisher.com

📘 Facebook.com/EmersonAutomationSolutions

🌐 LinkedIn.com/company/emerson-automation-solutions

🐦 Twitter.com/emr_automation

Emerson Automation Solutions

Americas

McKinney, Texas 75070 USA
T +1 800 558 5853
+1 972 548 3574

Europe

Bologna 40013, Italy
T +39 051 419 0611

Asia Pacific

Singapore 128461, Singapore
T +65 6777 8211

Middle East and Africa

Dubai, United Arab Emirates
T +971 4 811 8100

D100637X012 © 1984, 2021 Emerson Process Management Regulator Technologies, Inc. All rights reserved. 04/21.

The Emerson logo is a trademark and service mark of Emerson Electric Co. All other marks are the property of their prospective owners. Fisher™ is a mark owned by Fisher Controls International LLC, a business of Emerson Automation Solutions.

The contents of this publication are presented for informational purposes only, and while every effort has been made to ensure their accuracy, they are not to be construed as warranties or guarantees, express or implied, regarding the products or services described herein or their use or applicability. All sales are governed by our terms and conditions, which are available upon request. We reserve the right to modify or improve the designs or specifications of such products at any time without notice.

Emerson Process Management Regulator Technologies, Inc does not assume responsibility for the selection, use or maintenance of any product. Responsibility for proper selection, use and maintenance of any Emerson Process Management Regulator Technologies, Inc. product remains solely with the purchaser.

