

November 2015

Type C404-32 Flanged Internal Valve

WARNING

Failure to follow these instructions or to properly install and maintain this equipment could result in an explosion and/or fire causing property damage and personal injury or death.

Fisher® equipment must be installed, operated and maintained in accordance with federal, state and local codes and Emerson Process Management Regulator Technologies, Inc. (Emerson™) instructions. The installation in most states must also comply with NFPA No. 58 and ANSI Standard K61.1.

Only personnel trained in the proper procedures, codes, standards and regulations of the LP-Gas industry should install and service this equipment.

The internal valve must be closed except during product transfer. A line break downstream of a pump may not actuate the excess flow valve. If any break occurs in the system or if the excess flow valve closes, the system should be shut down immediately.

Introduction

Scope of the Manual

This manual covers instructions for the Type C404-32 internal valves and the manual, cable or pneumatic actuators for the valve.

Description

The Type C404-32 is typically used on the inlets and outlets of transport truck tanks and large stationary storage tanks. They can also be installed in-line. Designed for propane, butane or NH₃ at ambient temperatures, the valves can be used on other compressed gases, but the user should check with the factory to make sure the valve is suitable for the particular service.

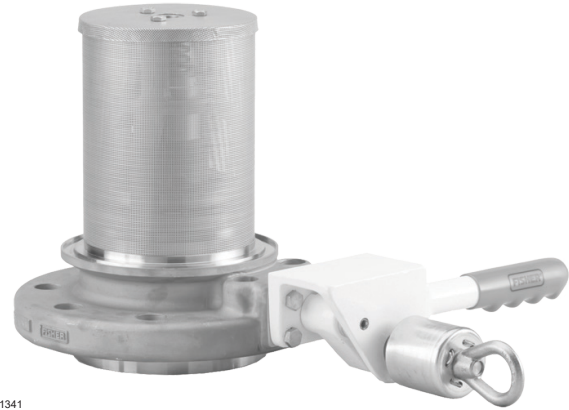

Figure 1. Type C404M32 Internal Valve

The following accessories for the Type C404-32 are also covered:

Type P313 – Latch/remote release mechanism that permits remote valve closure. The valve is opened manually.

Factory type number with the Type P313 installed is Type C404M32.

Type P614A – Pneumatic actuator that allows remote opening and closing of the valve. Factory type number with the Type P614A installed is Type C404A32.

Type P314 – Cable assembly for connection from the valve's operating lever to a cable control.

Type P315 – Remote release handle that permits valve closure from a remote point.

DOT Internal Self-Closing Stop Valve Requirement— U.S. Department of Transportation (DOT) regulations 49CFR§178.337-8(a)(4) require each liquid or vapor discharge outlet on cargo tanks (except for cargo tanks used to transport chlorine, carbon dioxide, refrigerated liquid and certain cargo tanks certified prior to January 1, 1995) to be fitted with an internal self-closing stop valve. The “C” Series internal valves comply with the internal self-closing stop valve requirement under the DOT regulations.

Type C404-32

Specifications

Body Sizes and End Connection Styles

Inlet: NPS 4 / DN 100⁽¹⁾, CL300 ASME RF Modified Flange (5.875 in. / 149 mm diameter bore)
Outlet: NPS 4 / DN 100, CL300 ASME Flange

Maximum Allowable Inlet Pressure

500 psig / 34.5 bar WOG

Excess Flow Springs

340, 400, 600, 800 or 1000 GPM /
 1287, 1514, 2271, 3028 or 3785 LPM

Temperature Capabilities

-40 to 150°F / -40 to 66°C

Body Material

Stainless steel

Approximate Weight

50 lbs / 23 kg

1. Nominal pipe size.

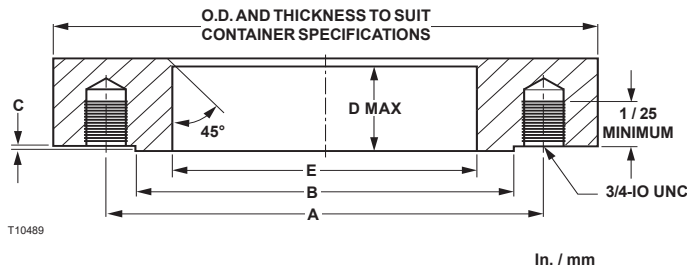

Figure 2. Tank Flange Dimensions

Table 1. Tank Flange Dimensions, In. / mm

FLANGE CL300 ASA	A-BOLTING			B RF	C RF	D	E	MATING FLANGE O.D.
	DBC	NO.	SIZE					
4 / 102	7.88 / 200	8	3/4 / 19	7 / 178	0.06 / 1.5	1.56 / 40	5.88 / 149	10 / 254

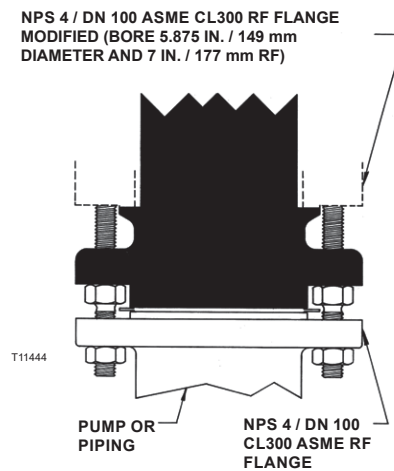

Figure 3. Valve Installation Schematic

Installation

Internal Valve

Coat both sides of the spiral wound gaskets with silicone grease or equivalent. An NPS 4 / DN 100, CL300 ASME RF flange with a modified bore (see Figure 2) must be installed in the tank. Special stud bolts, furnished with the valve, are assembled into this flange. The internal valve and the pump or piping flange can then be installed as shown in Figure 3.

The screen should be removed if the valve is to be used for both filling and withdrawal service or for filling alone. Filling with screen installed is not recommended.

A hydrostatic relief valve does not need to be installed adjacent to the valve since the internal valve automatically relieves excessive line pressure into the tank.

Keep piping from the valve outlet to the pump full size and as short as possible with a minimum of bends. Reduction in pipe size to suit smaller pump inlets should be made as

close to the pump as possible using forged reducers (swage nipples) or venturi tapers rather than bushings. This assures minimum flow resistance and efficient pump operation.

The operating linkage must allow the operating lever to move from the fully closed position to within 2° of the full open position. The linkage should not apply strong force to the lever past the full open position or the valve could be damaged.

If the valve is also used to provide excess flow protection, the flow rating of the piping, fittings, pump, valves and hose on both the inlet and outlet of the internal valve must be **greater** than the flow rating of the integral excess flow valve within the internal valve. If branching or other necessary restrictions are incorporated in the system which reduce the flow rating to less than that of the excess flow valve rating, the internal valve will not give excess flow protection.

Selectively Filling Manifolded Tanks

Fisher® internal valves provide positive shutoff only in one direction, from out of the tank to downstream of the valve. The internal valves are designed to allow gas to flow into a tank when the downstream line pressure exceeds tank pressure. If you want to selectively fill one or more of the other tanks in a tank manifold system, you must place a positive shutoff valve downstream of the internal valve, otherwise, all tanks will be filled at the same time and at about the same rate.

Actuators

Type P314 – On Type C404-32 valves, insert the cable through the hole in the operating lever until the fuse link portion fits tightly in the hole, see Figure 4. Make sure the cable runs through the slotted portion of the operating lever.

A remote operating handle, such as those manufactured by Allegheny or Wheaton, is attached to the other end of the Type P314 cable. Since the remote operating system for the valve is extremely important, it must be installed to conform to applicable codes. DOT MC-331, for example, most generally applies for trucks; refer to the most recent revision of this code. Any control system requires thermal protection (fuse links) at the valve, at the remote control point and – if necessary – near the hose connections.

Rotate the valve's operating lever by hand to the position shown in Figure 4. In this position the valve's cam is just contacting the valve stem and the cable can be attached to the remote operating handle. Check to see that the valve closes properly and that the operating lever returns to its original position. There should be a little slack in the cable.

Type P614A – If the pneumatic actuator has not been factory installed (Type C404A32), remove the cable type operating lever by driving out the roll pin. Remove the four cap screws and the face plate. Attach the collar to the stub shaft as shown and secure the bracket and actuator to the valve body with the four bolts furnished with the kit, see Figure 8.

Type P614A or C404A32 must be operated by at least 40 psig / 2.7 bar air or nitrogen; maximum actuator pressure is 125 psig / 8.6 bar. On trucks with air brakes, the Fisher air actuation hook-up can be used to operate the valve, refer to manual D45016T012.

Types P313 and P315 – If the Type P313 manual operating lever and release mechanism has not been factory installed (Type C404M32), remove the cable type operating lever by driving out the roll pin. Remove the four cap screws and the face plate. After attaching the collar to the valve's stub shaft, bolt the bracket and mechanism to the body, see Figure 9.

To install Type P315 remote release handle on Type C404M32s, refer to the schematic installation drawing in Figure 5. The hook-up may require two

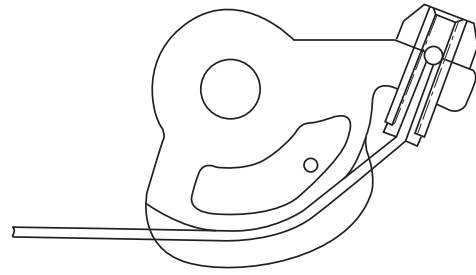

Figure 4. Type P314 Cable Attachment

Type P315s (refer to MC-331) and enough pulleys to keep the cable away from the tank. The cable must be taut for proper operation. Pulling the Type P315 handle allows the manual operating lever to return to the closed position. Fusible links in both the Types P313 and P315 melt if exposed to fire, permitting the valve to close.

When closing the Type C404M32 manually, grasp the lever firmly and pull down. At the same time pull back on the cable eyelet attached to the release mechanism as the manual lever is pulled downward and then allow the lever to move upward.



WARNING

Since there is strong spring force on the operating lever, avoid getting in the way of lever if it slams to the closed position. The lever should not be allowed to slam to the closed position except in emergency situations, as repeated slamming may damage the valve and operator.

Excess Flow Operation

The internal valve contains an excess flow function or “integral excess flow valve”, that will close when the flow exceeds the flow rating established by Fisher. Fisher integral excess flow valve installed on a bobtail truck or transport can provide protection against the discharge of hazardous materials during an unloading operation of a bobtail truck or transport in the event that a pump or piping attached directly to the internal valve is sheared off before the first valve, pump or fitting downstream of the internal valve, provided that the cargo tank pressure produces a flow rate greater than the valve's excess flow rating.

Likewise, if the internal valve is installed on a stationary tank or in the related downstream piping system, the integral excess flow valve can provide protection against an unintentional release of hazardous materials in the event that a pump or piping attached directly to the internal valve is sheared off before the first valve, pump or fitting downstream of the internal valve, provided that the flow of product through the internal valve reaches the rated flow specified by Fisher.

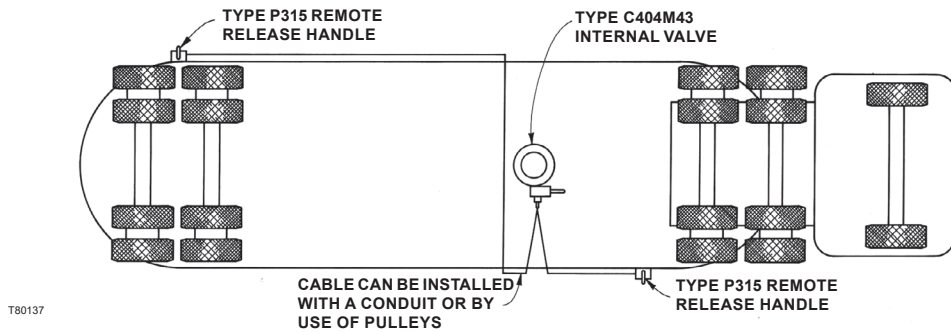

Figure 5. Type P315 Installation Schematic



EXPLOSION HAZARD

Restrictions incorporated in the discharge system of a bobtail truck or transport or of a stationary tank (due to pumps, pipe and hose length and dimensions, branching, elbows, reductions in pipe diameter or a number of other in-line valves or fittings), low operating pressure as a result of ambient temperature or a partially closed valve downstream from the integral excess flow valve, can restrict the rate of flow through the internal valve below the level necessary to actuate the integral excess flow valve. Therefore, **DO NOT USE** the excess flow function of the internal valve for the purpose of providing protection against the discharge of hazardous materials in the event of a rupture of hose or piping at a point in the discharge system downstream from the first valve, pump or fitting downstream of the internal valve.

The internal valve is designed with an internal bleed feature for equalization of pressure. After the integral excess flow valve closes, the leakage through the bleed must be controlled or a hazard can be created. For this reason, the operator must be familiar with the closure controls for the internal valve and must close the internal valve immediately after the integral excess flow valve closes.

Failure to follow this warning could result in serious personal injury or property damage from a fire or explosion.

DOT Passive Shutdown Equipment Requirement—

DOT regulations 49CFR§173.315(n)(2) require certain cargo tanks transporting propane, anhydrous ammonia and other liquefied compressed gases to be equipped with passive emergency discharge control equipment that will automatically shut off the flow of product without human intervention within 20 seconds of an unintentional release caused by complete separation of a delivery hose. The design for each passive shutdown system must be certified by a Design Certifying Engineer (DCE) and all components of the discharge system that are integral to the design must be included in the DCE certification. The DCE certification must consider any specifications of the original component manufacturer.

In the case of downstream ruptures in hose or piping, a variety of operating conditions routinely encountered during an unloading operation restrict the rate of flow through the integral excess flow valve and make such a valve unsuitable to serve as the means of passive shutdown required under 49CFR§173.315(n)(2). Such variables include restrictions incorporated in the discharge system (due to pumps, pipe and hose length and dimensions, branching, elbows, reductions in pipe diameter or a number of other in-line valves or fittings), low operating pressure as a result of ambient temperature or a partially closed valve downstream from the excess flow valve. Due to the variety of conditions, in the case of a hose separation, that can restrict the rate of flow below the level necessary to activate the excess flow valve, the integral excess flow function of “C” Series internal valves or “F” Series excess flow valves cannot be used to satisfy the passive shutdown equipment requirement under/in 49CFR§173.315(n)(2). Also, a Design Certifying Engineer cannot include the integral excess flow valve of a “C” Series internal valve or “F” Series excess flow valve as a component of the discharge system in any DCE certification under 49CFR§173.315(n)(2).

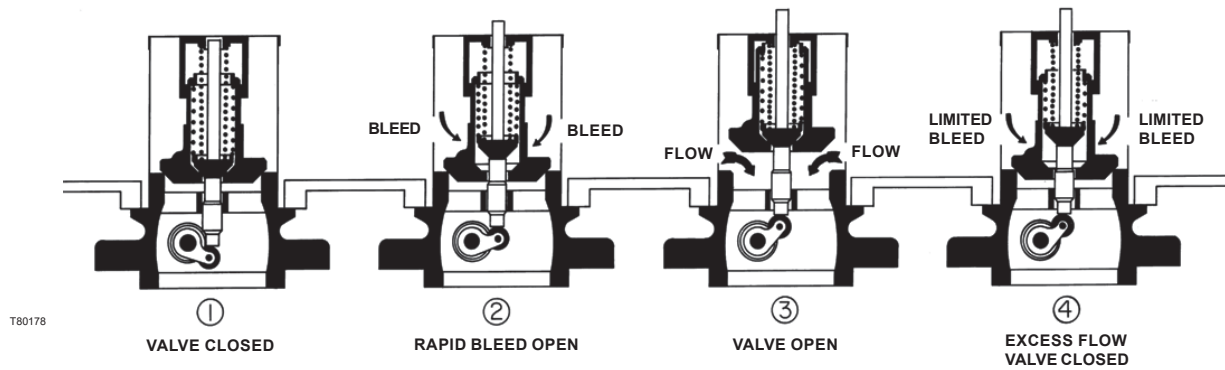

Figure 6. Operational Schematic



EXPLOSION HAZARD

DO NOT USE the excess flow function incorporated into “C” Series internal valves or “F” Series excess flow valves to satisfy the passive shutdown equipment requirement in 49CFR§173.315(n)(2). **DO NOT** include the excess flow function incorporated into “C” Series internal valves or “F” Series excess flow valves in a DCE certification under 49CFR§173.315(n)(2). The cargo tank manufacturer must install some other equipment that satisfies the requirement for passive shutdown capability under 49CFR§173.315(n)(2).

Failure to follow this warning could result in serious personal injury or property damage from a fire or explosion in the event of an unintentional release of product during an unloading operation.

Operation

Since the Type C404-32 is most often used on transport trucks, the following procedure applies to that type of application.

1. Always open the internal valve before starting the pump and before opening the valve on the pump outlet.
2. Normally leave the pumping system “wet” to avoid repeated drying of the seals and to reduce time in opening the internal valve. Drain the piping only when codes or safe operating practices require.
3. If piping is dry or at lower pressure than the tank, open the internal valve only about halfway for a few seconds so that line pressure can equalize before fully opening the operating lever. The valve may not equalize if the operating lever is moved to the fully open position.

4. Avoid flow surges which could close the built-in excess flow valve. If the valve should “slug” shut, stop the pump, close the nearest downstream valve and move the lever to mid-position to speed equalizing until the valve opens. There will be an audible click when the valve opens.
5. Always leave the valve closed except when transferring product.
6. All valves should be completely open when pumping. (Throttling type valves could prevent the excess flow valve from closing when required.)
7. The operator must always be aware of where the remote closure controls are located and know how to operate the controls if any emergency requires valve closure.

Troubleshooting

Internal Valve Will Not Open – This could be due to leakage downstream, engaging the pump too soon or from excessive wear in the internal valve. If excessive volume is in the downstream system, a longer time is required to equalize the pressures (tank and downstream) before the pump can be engaged. To determine if the valve pilot seat is opening, install a gauge downstream of the valve, operate the valve actuator; if pressure does not buildup to the tank pressure, the valve pilot seat is not open. This test should be done with pump off. If the pilot is not opening, it may be plugged with dirt or some internal part may be broken. If by operating the lever manually it can be rotated past the fully open position, there is something wrong internally and the valve must be disassembled.

Premature Valve Closure – An improperly connected operating lever which does not fully open the valve (see the “Installation” section) is the first thing to look for. This condition could also be caused from engaging the pump too soon, sudden lines surges or an underrated excess flow spring. The trouble could stem from a valve that has its inlet port obstructed.

Type C404-32

Internal Valve Will Not Close – Most frequently due to a faulty or sticking actuator. Before disassembling the valve, check the actuator mechanism to see that it works freely by disconnecting it from the valve lever and cycling it several times. Also, operate the valve lever manually. If it sticks in the open position, the packing and bushings should be replaced which should free the operating mechanism if the valve does not have internal damage.

Low Flow Capacity – Too small or long downstream piping might be being used. Other possibilities include a plugged screen or strainer, some restriction downstream system or a bypass valve sticking in the open position. The bypass valve could also be set too low and be opening prematurely. Check for high differential pressure across the internal valve to determine if it is at fault. If the valve is open, there should never be over 5 or 6 psig / 0.35 or 0.41 bar differential across the valve.

Principle of Operation

Refer to the schematic drawing, Figure 6. In View 1, the valve is held closed by both tank pressure and the valve's closing spring. There is no leakage past the resilient seats in the poppet to the valve outlet.

The valve is opened by moving the operating lever to approximately mid-point in its 70° travel (View 2). This allows the cam to place the rapid equalization portion of the valve stem in the pilot opening, permitting a larger amount of product to bleed downstream than if the operating lever were moved to the full open position. When tank and downstream pressure are nearly equal after a few seconds, the excess flow spring pushes open the main poppet (View 3) and the operating lever can be moved to the full open position.

If tank pressure is greater than the valve's outlet pressure, the main poppet will remain in the closed position. If valve outlet piping is closed off by other valves, however, product bleeding through the pilot will increase until it nearly equals tank pressure and the main poppet opens.

Note

The main poppet will not open if valve outlet piping is not closed off so that the outlet pressure can approach tank pressure.

Once the main poppet opens, a flow greater than the valve's excess flow spring rating or a sufficient surge in flow forces the main poppet closed against the excess flow spring (View 4). The pilot valve allows a small amount of product to bleed, but much less than (View 2) where the rapid equalization portion of the stem is placed in the pilot opening. When the operating lever is moved to the closed position, the valve closes completely and seals tightly (View 1).

Maintenance



Do not use these internal valves if they leak, fail to work properly or have been damaged or have missing parts. Prompt repairs should be made by a properly trained service person. Continued use without repair can create a hazardous or injurious situation.

A simple preventative maintenance program for the valve and its controls will eliminate a lot of potential problems.

Fisher® recommends these steps be conducted once a month. Also refer to the Department of Transportation (DOT) CFR 49 Sections 180.416 and 180 Appendix A and B which specific monthly maintenance and inspection tests for cargo tank service internal valves and their actuation controls.

1. Inspect the operating lever to see that it moves freely and smoothly. Also examine the stub shaft bonnet nuts for leakage using a soap solution. If there is leakage, the bonnet packing will have to be replaced. A sticking lever indicates mechanism wear or trapped dirt. This could mean the need for new shaft seals, shaft bushings or stem bushings.
2. Check for tight closure of the seat discs. Any detected leakage, which is normally caused by disc wear or dirt, scale or debris embedded in the disc, requires that the internal valve be removed from service and repaired. Repair most often requires the replacement of valve discs. To check for leakage:
 - a. Close the internal valve and exhaust downstream pressure. Close the first valve downstream from the internal valve and note any pressure buildup, using a pressure gauge, between the closed valve and the internal valve. If piping is cold, allow it to warm to ambient temperature.
 - b. Refer to CFR 49 Section 180 Appendix B for Meter Creep Test Methods.
3. All operating controls should be inspected, cleaned and oiled. The controls should be checked to see that they fully open—but not over-travel—the internal valve operating lever and work freely to close the valve.
4. Standard construction internal valves must be removed if the container is to be steam cleaned. Heat can damage the valve's seats and seals.
5. Standard construction internal valves are not designed for water service. Immediately after a container is hydrostatically tested, remove all water and allow the container to thoroughly dry out.

Disassembly



WARNING

Tank pressure must be released before removing the valve from the container. Failure to do so could result in personal injury.

Numbers in parenthesis refer to key numbers in Figure 7.

To Replace Packing

Note

When using kits RC40432T012, RC404M32T12 or RC404A32T12, please mark the nameplate with an 'R' to indicate the valve has been Retrofitted with the proper kit.

1. Remove the operating lever assembly from the stub shaft (key 4).
2. Drive out the pin (key 7) holding the cam (key 6) to the stub shaft and slide the stub shaft out of the body.
3. Remove the face plate (key 16) by taking out four screws (key 17). The guide (key 13), packing (keys 10 and 2) can then be removed.
4. Besides the packing, the liner bushing (keys 3 and 14) and the O-ring (key 15) should be replaced. Also check the Polytetrafluoroethylene (PTFE) washer (key 5) and replace it if necessary.
5. A new face plate (key 16) is furnished with the packing kit so that the packing and the guide (key 13) can be pressed into the body when reassembling.
6. Reassemble in reverse order. Replace cap screw (key 17) using 25 to 30 ft-lbs / 33.9 to 40.7 N•m torque.
7. Make sure the operating lever can move freely after the new parts are installed. Conduct a leak test under pressure with a soap solution.

To Replace Seat Discs and Seat Ring

1. Unscrew the six flange screws (key 29) holding the valve cage (key 28) and seat ring (key 82) to the body (key 1). Remove the cage from the body.
2. The seat ring can be examined and replaced if necessary. Replace the O-ring (key 83). Be careful reinstalling the seat ring so as not to damage the O-ring (key 83). Lubricate the O-ring with Multi-Purpose PTFE Lubricant before attempting to replace the seat ring.
3. To replace the seat discs (keys 19 and 20), remove the bolts (key 22) holding the disc retainer (key 21) to the disc holder (key 18).

4. Examine both seat discs (keys 19 and 20) and replace if necessary.
5. Reassemble in reverse order using 10 to 15 ft-lbs / 13.6 to 20.3 N•m torque to install the disc retainer bolts (key 22) and 4 to 5 ft-lbs / 13.6 to 6.8 N•m torque on the six flange screws (key 29).

Type P614A Piping For Bulk Storage Installation

There are numerous piping arrangements using single or multiple internal valves, in one or more tanks. The following suggests possible piping schematics to operate Type C404-32 internal valves mounted with Type P614A Pneumatic actuators. Other piping arrangements could be used as each installation may have different requirements. Consult your local Sales Office, state and federal codes for each installation.

General Instructions

Remove the shipping plug from the Type P614A actuator and "Supply" port.

Use a good grade of pipe compound on all pipe fittings and connections.

Thermal Release

A 212°F / 100°C Fuse Plug, Fisher® Part Number T1033699982, is installed in the Type P614A actuator. The fuse plug will exhaust supply pressure if fire impinges on the fuse plug and allows the internal valve to close by exhausting supply pressure.

Restricting Orifice in Supply Line

Install a restricting orifice, #50 Drill (0.070 in. / 1.8 mm diameter) in the supply line leading to the actuating valve. This will limit flow to the system so when a fuse plug opens, the system will exhaust faster than the incoming supply source.

Exhaust Port Protection

All exhaust ports must be protected from plugging, freezing or any other inadvertent closure if no pressurized piping is installed to aid in actuator closure. A Fisher Y602 Series vent assembly can be installed at any exhaust port. If exhaust piping is used, it should be installed and piped to a protected location and the Y602 Series vent assembly installed on the end of the exhaust piping. The Y602 Series vent should be pointed down to prevent plugging or closing the exhaust port.

Select the Y602 Series vent style and size that fits the application and piping size.

Type C404-32

Table 2. Type C404-32 Kit Selection Table

MANUFACTURING DATE	WAS IT RETROFITTED?	VALVE TYPE	PART NUMBER	DESCRIPTION
Before 3/15/2012	No	All	RFC40432T12	4 in. Packing Retrofit Kit
		C404-32	ERAA03396A0 ⁽²⁾	Type C404-32 Hardware
After 3/15/2012	Yes	All	T11396000B2	New-Style Packing Kit
	N/A ⁽¹⁾	All	T11396000B2	New-Style Packing Kit

1. Retrofit kits only needed on valve manufactured prior to 3/15/2012.
2. Type C404-32 requires both RFC40432T12 and ERAA03396A0.



WARNING

All exhaust ports, must be protected so that they do not become plugged with insects, ice, pipe fittings, etc. A plugged exhaust port will not let the internal valve(s) close.

Parts Ordering

When corresponding about this equipment, always reference the type number found on the nameplate. When ordering replacement parts, reference the complete 11-character part number of each needed part.

Parts List

Types C404-32 (Figure 7), C404A32 (Figure 8) and C404M32 (Figure 9) Internal Valves

See Table 2 to determine which replacement kit to order.

Key	Description	Part Number
	Packing Retrofit Kit for Types C404-32, C404M32 and C404A32 valves includes keys 3, 8, 10, 11, 12, 13, 14, 15 and 17 for packing retrofit only. (Type C404-32 packing retrofit kit also requires ERAA03396A0).	RFC40432T12
	Type C404-32 Cable Pulley Kit ONLY includes keys 16 and 39	ERAA03396A0
	Packing Replacement Parts Kit includes keys 3, 10, 11, 12, 14 and 15: For use only after fitment of Type RFC404 Kit ⁽¹⁾ .	T11396000B2
	Seals Replacement Parts Kit includes keys 19, 20 and 83	T11396000C2
	Seals Replacement Parts Kit for Y-Gas applications includes keys 19**, 20** and 83**	RC404YGT012

Key	Description	Part Number
1	Body, Stainless steel	T80199T0012
2*	Bushing, 410/416 Stainless steel	T11175X0012
3*	Liner Bushing, Polytetrafluoroethylene (PTFE)	T1117806992
4	Stub Shaft, 316 Stainless steel	T1117335162
5	Washer, PTFE	T1116301012
6	Cam Assembly	T11185T0012
7	Clevis Pin, Stainless steel	T11473T0012
8	Packing Spring, Inconel®	T14114T0012
9	Washer, 316 Stainless steel	1F125036042
10*	Male Adaptor, PTFE	1F124601012
11*	Packing Ring, PTFE (3 required)	1C752801012
12*	Female Adaptor, PTFE	1F124201012
13	Packing Follower, 410/416 Stainless steel	ERSA01564A0
14*	Liner Bushing, PTFE	ERSA01565A0
15*	Rod Wiper/O-ring, Polyurethane (PUR)	T1116606832
16	Stuffing Box Plate, Zinc-plated steel	ERSA01607A0
17	Hex Head Cap Screw, Zinc-plated steel (4 required)	T1133624052
18	Disc Holder, Stainless steel	T20842T0012
19*	Disc, Nitrile (NBR)	T1116703202
19**	Disc, Emerson™ Formulation for Y-Gas	ERAA05475A0
20*	Disc, Nitrile (NBR)	T1116803202
20**	Disc, Emerson Formulation for Y-Gas	ERAA05476A0
21*	Disc Retainer, 304 Stainless steel	T11162T0012
22	Cap Screw, Stainless steel (4 required)	T11187T0012
23*	Stem Assembly, Stainless steel/Nitrile (NBR)	T11183000A2
24	Excess Flow Spring, 302 Stainless steel Closing Flow - Propane 340 GPM / 1287 LPM, Red 400 GPM / 1514 LPM, Black 600 GPM / 2271 LPM, Green 800 GPM / 3028 LPM, Silver 1000 GPM / 3785 LPM, Unpainted	T1117037022 T1200137022 T1117137022 T1200237022 T12922T0012
25	Retainer, 304 Stainless steel	T11169T0012
26	Roll Pin, Stainless steel	1A9184T0012
27	Main Spring, 302 Stainless steel	T1117437022
28*	Valve Cage, Stainless steel	T40422T0012
29	Flange Screw, Stainless steel (6 required)	T13325T0012
30	Strainer, Stainless steel	T2027438992
31	Retainer, 304 Stainless steel	T2027338992
32	Cap Screws, Stainless steel (3 required)	1E6208T0012
33*	Upper Spiral Wound Gasket, 304 Stainless steel/Graphite (Not shown)	1P110799152
34*	Lower Spiral Wound Gasket, 304 Stainless steel/Graphite (Not Shown)	ERSA03240A0
35*	Stud Bolts (Not Shown) (8 required)	T1118131032
36*	Hex Nut (Not Shown) (16 required)	1A368124112
38	Drive Screw, Plated carbon steel (Not Shown) (2 required)	1E501728982

*Recommended spare parts

**For Y-Gas applications

Inconel® is a mark owned by Special Metals Corporation.

1. Valves with MFG Date stamped after DATE should be fitted with corresponding Type RFC404 kit before this kit applies.

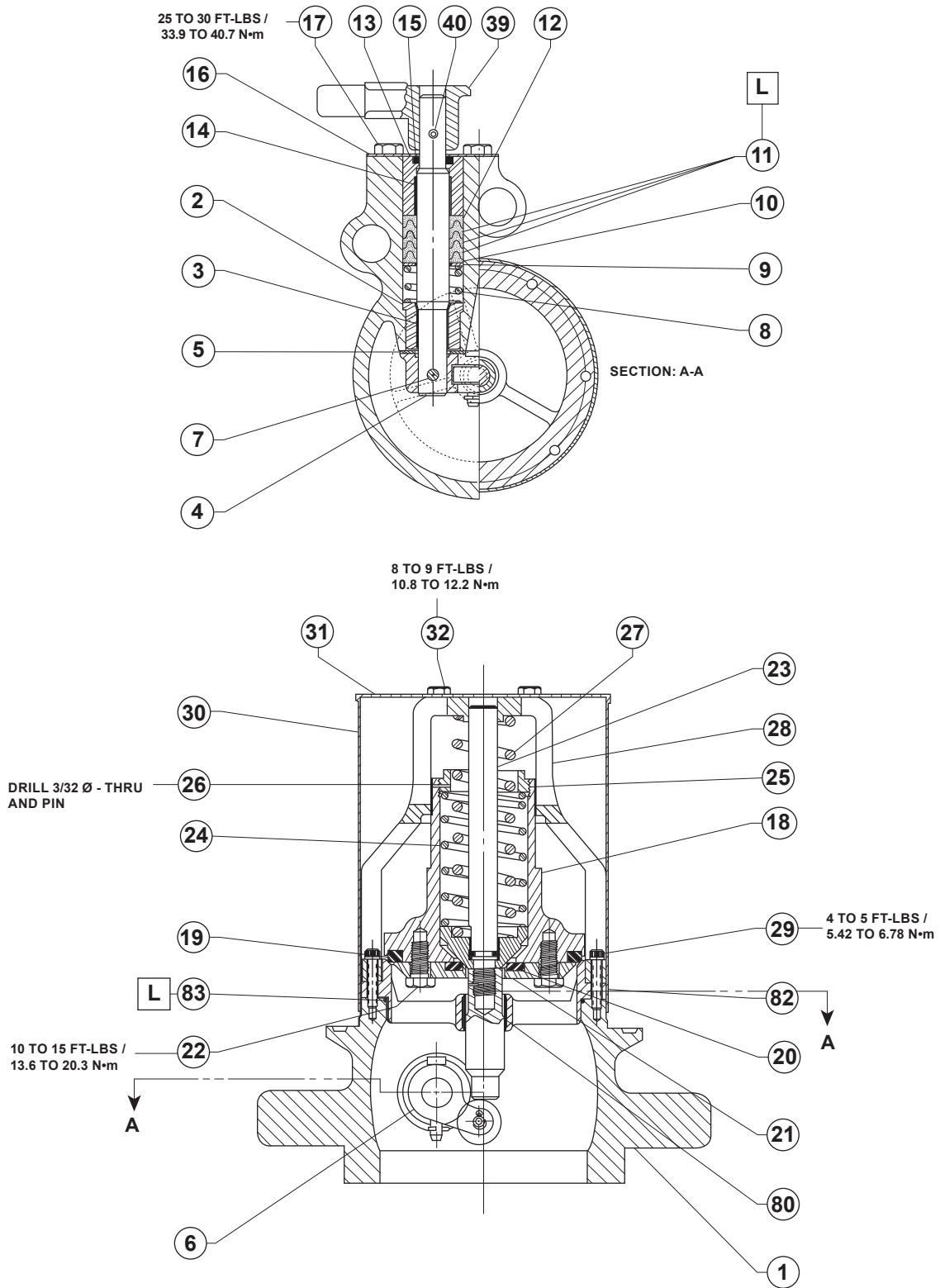
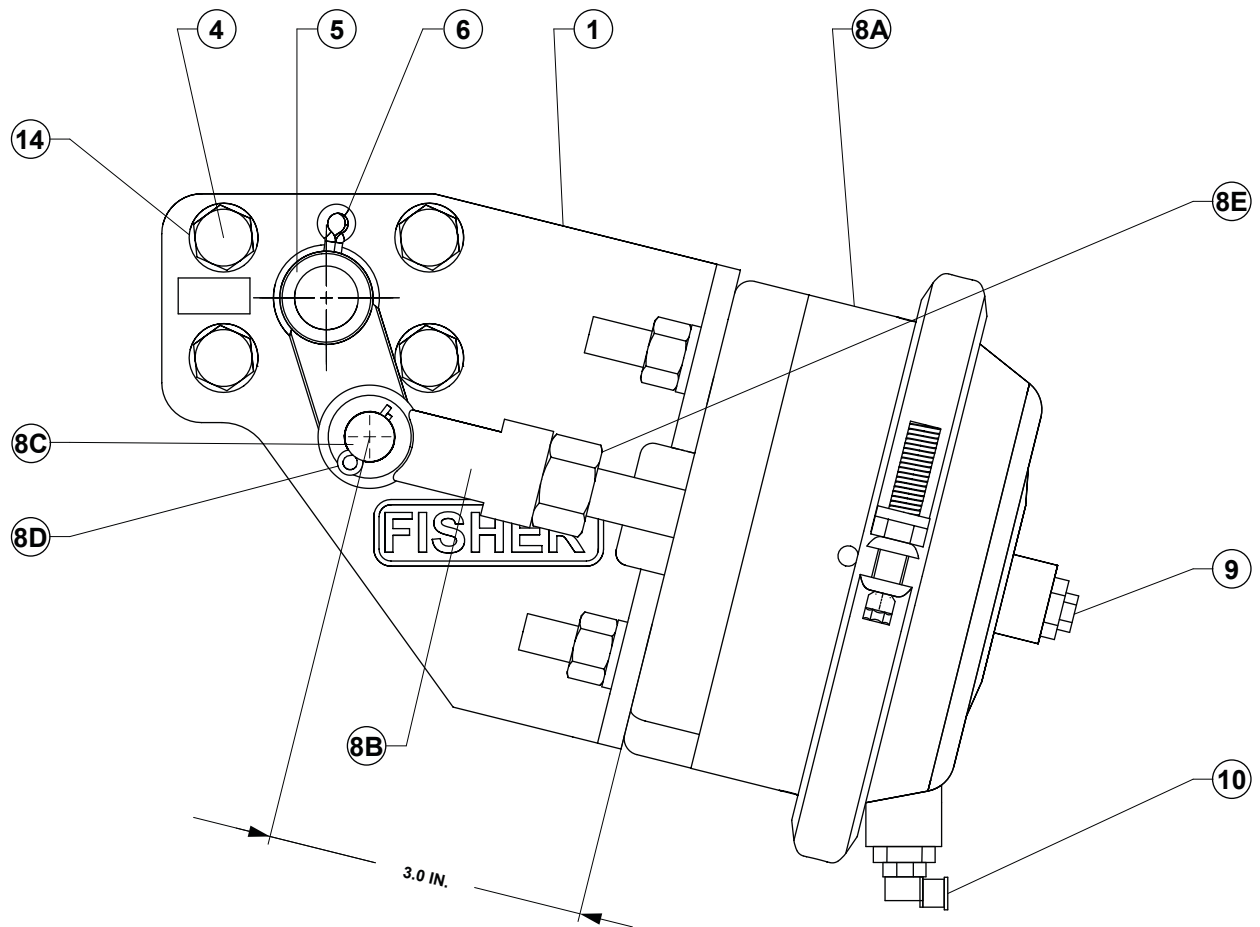

Figure 7. Type C404-32 Flanged Internal Valve Assemblies

Type C404-32



GE31240

Figure 8. Type P614A Assembly

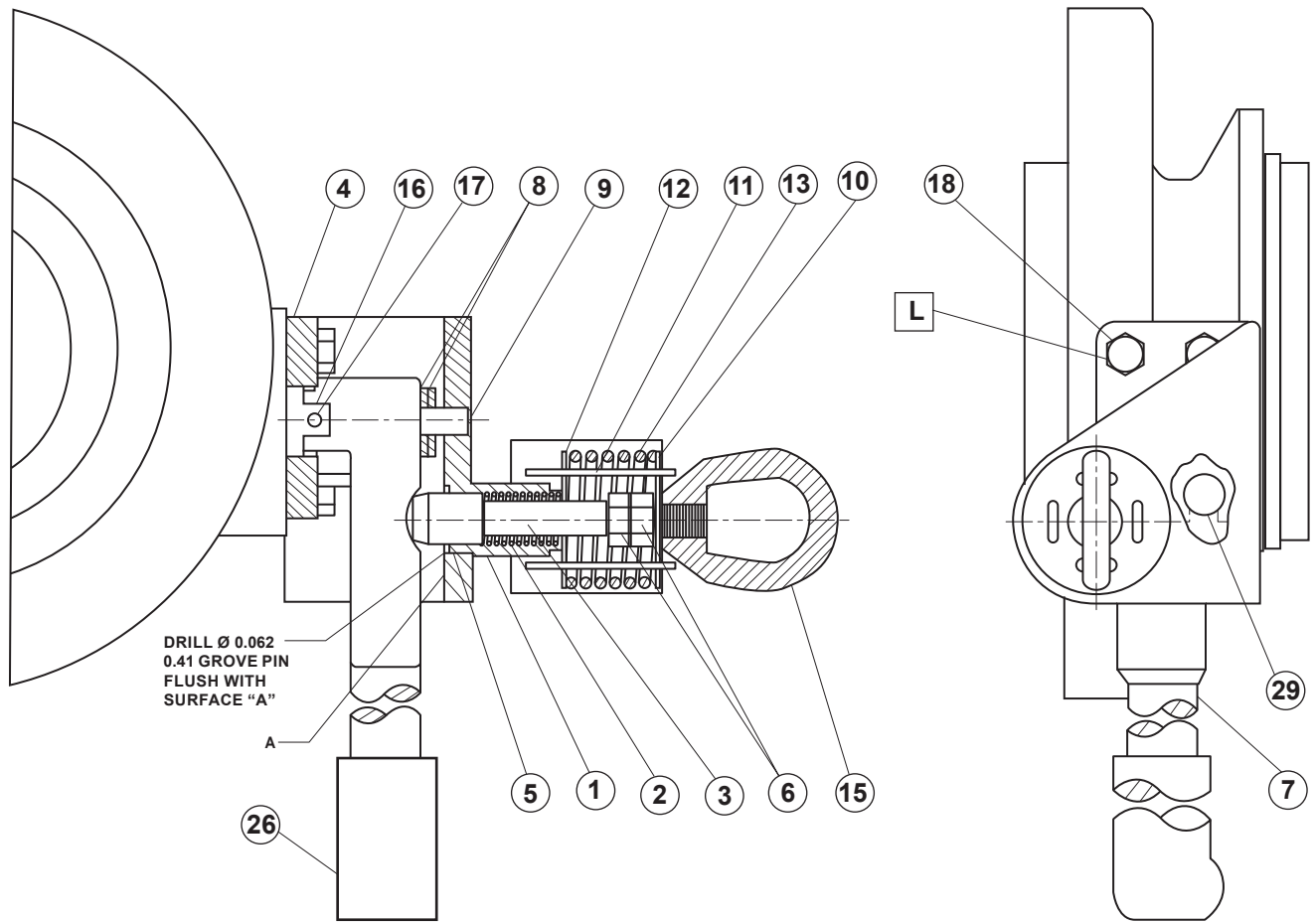

T40107

APPLY LUBRICANT

Figure 9. Type P313 Assembly

Type C404-32

Types C404-32 (Figure 7), C404A32 (Figure 8) and C404M32 (Figure 9) Internal Valves (continued)

Key	Description	Part Number
39	Pulley, Cast iron	ERSA01604A0
40	Roll Pin, Plated carbon steel	T1133528982
41	Spring Lock Washer, Plated carbon steel (4 required) (Not Shown)	1A505628982
79	Fusible Link (Not Shown)	1J157443992
80	Liner Bushing, PTFE	T1249806992
82*	Seat Ring, 316 Stainless steel	T20843T0012
83*	O-ring, Nitrile (NBR)	14A5688X012
83**	Disc, Emerson™ Formulation for Y-Gas	14A5688T042

Type P614A Pneumatic Actuator (Figure 8)

Key	Description	Part Number
	Brake Chamber Assembly Repair Kits (include keys 8A, 8B, 8C, 8D and 8E)	GE40920X012
1	Mounting Bracket, 304 Stainless steel	GE45399X012
4	Hex Head Cap Screw, Zinc-plated carbon steel (4 required)	T1133624052
5	Lever, 303 Stainless steel	GE45407X012
6	Cotter Pin, Plated carbon steel	1H837128982
8	Brake Chamber Assembly	
8A	Brake Chamber	GE40919X012
8B	Clevis	GE33509X012

Key	Description	Part Number
8C	Clevis Pin	GE33511X012
8D	Cotter Pin	GE33526X012
8E	Hex Nut	T12086X0022
9	Fuse Plug	T1033699982
10	Push-in Fitting, Brass	GE33586X012
14	Spring Lock Washer, Plated carbon steel (4 required)	1A505628982

Type P313 Latch/Remote Release (Figure 9)

Key	Description	Part Number
1	Stem Guide, Plated carbon steel-PTFE	T1135824102
2	Spring, 302 Stainless steel	T1135937022
3	Plunger, 303 Stainless steel	T1136035032
4	Bracket, Ductile iron	T2031119172
5*	Groove Pin, Plated carbon steel	1D7991X0012
6	Nut, Zinc-plated steel (2 required)	1A352424122
7	Lever, Cast iron	T2031319042
8	Washer, Plated carbon steel (2 required)	T1136128992
9	Roll Pin, 420 Stainless steel	T1136236402
10	Washer, Plated carbon steel	T1136328982
11	Fusible Link (4 required)	1J157443992
12	Washer, Plated carbon steel	T1136428982
13	Spring, 17-7 Stainless steel	T1136537082
14	Cover, Plated carbon steel	T1068428982
15	Eye Nut, Alloy steel-plate	1P111932992
16	Collar, 410/416 Stainless steel	T1133435132
17	Roll Pin, Plated carbon steel	T1133528982
18	Cap Screw, Zinc-plated steel	1A336924052
26	Handgrip	T12928T0012
29	Capscrew, Zinc-plated steel (2 required)	1A341824052

*Recommended spare parts

**For Y-Gas applications

LPG Equipment

Emerson Process Management Regulator Technologies, Inc.

USA - Headquarters
 McKinney, Texas 75070 USA
 Tel: +1 800 558 5853
 Outside U.S.: +1 972 548 3574

For further information visit www.fisherregulators.com

The Emerson logo is a trademark and service mark of Emerson Electric Co. All other marks are the property of their prospective owners. Fisher® is a mark owned by Fisher Controls International LLC, a business of Emerson Process Management.

The contents of this publication are presented for informational purposes only, and while every effort has been made to ensure their accuracy, they are not to be construed as warranties or guarantees, express or implied, regarding the products or services described herein or their use or applicability. We reserve the right to modify or improve the designs or specifications of such products at any time without notice.

Emerson Process Management Regulator Technologies, Inc. does not assume responsibility for the selection, use or maintenance of any product. Responsibility for proper selection, use and maintenance of any Emerson Process Management Regulator Technologies, Inc. product remains solely with the purchaser.