



KEYSTONE COMPOSEAL BUTTERFLY VALVES, WAFER STYLE INSTALLATION AND MAINTENANCE INSTRUCTIONS

Before installation these instructions must be fully read and understood

Intended valve use

The valve is intended to be used only in applications within the pressure/temperature limits indicated in the P/T diagram of the product manual.

The CompoSeal wafer butterfly valve is designed for wafer use only. No dead end service!

Ensure that valve materials are compatible with the pipeline fluid.

1 STORAGE AND HANDLING

1.1 Protection

Keystone butterfly valves are delivered with protection in accordance with the Keystone Engineering Instructions, to protect the valve from damage. Wrapping and/or covers should be left in place until installation of the valve.

1.2 Storage

When valves are to be stored for some time (2 months or more) before being fitted, storage should be in the original delivery crates or cases.

1.2.1 Storage conditions

The valves should be stored off the ground in a clean, dry indoor area.

Protect the valve from temperature and humidity extremes, and exposure to excessive dust, moisture, vibration, deformations, sunlight and ozone.

Recommendations

1. Temperature: storage temperature below 25°C (77°F), above 0°C (32°F) preferable below 15°C (60°F).
2. Humidity: storage conditions should be such that condensation does not occur, store in a dry environment. Maximal 50% relative humidity.
3. Light: valve rubbers should be protected from light, in particular direct sunlight or strong artificial light with high ultra violet.
4. Ozone: storage rooms should not contain any equipment generating ozone. E.g. lamps, electric motors.

IMPORTANT

Before valves are being installed or used the following actions are recommended.

1. *Valves/parts have to be inspected and thoroughly cleaned if required.*
2. *Rubber parts need to be greased with silicone grease if not present anymore.*
3. *All surfaces in contact with seats have to be thoroughly cleaned and greased with silicone grease if stored for more than 5 months.*

1.3 Handling

To prevent damage during handling, the valves should be lifted by hand or using appropriate lifting equipment. The valves should be protected from external events e.g. bumps, hitting and vibrations during transport. Any flange protection needs to be removed before the valve is mounted in the pipeline. Lift the valve with great care from the transport package (crate, pallet). While handling or installing the valve, ensure that no damage occurs to the valve, the pneumatic/electrical or hydraulic actuator or other instruments.

2 INSTALLATION

WARNING

For safety reasons it is important to take the following precautions before starting to work on the valve:

1. *Personnel making any adjustment to the valves should utilize suitable equipment. All required personal protection means should be worn.*
2. *The line must be depressurized before installing the valve.*
3. *Installation and handling of the valves should only be done by personnel that is trained in all aspects of manual and mechanical handling techniques.*
4. *Misuse of the valve is not allowed. The valve, handles, actuators and other parts may not be used as 'climbing tools'.*
5. *Ensure that valve pressure/temperature limitations marked on the valves tag plate are within the service conditions. The trim number on the valves tag plate identifies the valve materials. See Product Manual for valve specific P/T diagram and trim number definition.*

6. *Ensure that valve materials are compatible with the pipeline fluid.*

2.1 Visual valve inspection

1. Confirm that the materials of construction listed on the valve are appropriate for the service intended and are as specified.
2. Check if valve and actuator are not damaged during transport or handling.

KEYSTONE COMPOSEAL BUTTERFLY VALVES, WAFER STYLE

INSTALLATION AND MAINTENANCE INSTRUCTIONS

2.2 Flange and pipe compatibility

Check matching of flange drilling pattern of valve and pipe flange before assembly. Flanges have to meet the following requirements (Fig. 1):

- The face inside diameter should be:
 - D min: The valve Q dimension + adequate disc clearance.
 - D max: The optimum inside diameter (ID) is equal to the inside diameter of flange standard EN 1092-1, table 8, type 11. For larger than D max inside diameters or other flange types please contact your local Emerson Sales organization, as larger inside diameters might result in reduced valve functionality.
 - If the flange or pipe is provided with a raised face, the diameter of this shall be at least 8 mm larger than the YY-dimension of the valve.
- The O-ring design of the Keystone CompoSeal eliminates the need for gaskets. If for some reason required, flange gaskets can also be used. When flange gaskets are used (min. 1 mm / max. 2 mm thick rubber gaskets are recommended) the O-rings must be removed from the body. Use flange bolting in accordance with the appropriate standard.

2.3 Valve installation

The valves are bi-directional and can be fitted in either direction relative to the flow. The valve will control flow equally in either direction. The recommended installation position is shaft horizontal and the lower disc edge opening downstream (especially for slurry service and media with a tendency for sedimentation). For optimum valve control and smooth performance, it is recommended to have 10 to 20 pipe diameters of straight run inlet piping and 3 to 5 pipe diameters straight outlet piping. Do not use the valve as a crow-bar to spread the flanges, this might lead to damage to the flange area and/or damage to the O-ring sealing.

NOTES

- The valve can be installed in the pipeline either with or without the actuator mounted on top of the valve. Make sure you are able to turn the disc carefully to a more closed/open position to prevent the disc edge from touching the adjacent flanges while positioning the valve.
- It is the responsibility of the valve user - and not the valve manufacturer - to ensure that the pipeline system has been built professionally and the valve has been properly installed.
- Adjacent piping must be positioned so that minimal piping stresses are transmitted to the valve flanges during or after installation.

- Handling and lifting of the valves during installation must be performed following the same instructions described in the previous paragraph '1.3 Handling'.
- If an actuator or handle (especially the composite handle) is to be mounted on the valve, apply a little bit of grease to the shaft to ensure easy assembly. Avoid hammering or hitting on the handle or actuator during assembling at all times.
- Remove the 4 snap-off nibs for installing the valve between AS2129 E flanges DN 80 (NPS 3) only (Fig. 2).

IMPORTANT

Mating flange faces should be in good condition and free of dirt and/or inclusions. Both pipe insides must be well cleaned before installing the valve.

2.3.1 Existing system

1. Check whether the flange distance meets the valve face-to-face dimensions. Spread the flanges with adequate tooling for easy insertion of the valve.
2. Close the valve so far, that the disc edge is at least 10 mm within the body flanges.
3. Insert the valve between the flanges, pay extra attention to the flange sealing O-rings. Adequate flange spreading is required to prevent the O-rings from rolling out of its groove. Place 2 two flange bolts trough the pipe flanges and the locating lugs of the valve to support the valve.
4. Check if the flange sealing O-rings are still in place.
5. Center the valve body and insert all flange bolts. Tighten the flange bolts hand tight.
6. Slowly open the valve completely. The disc is in line with parallel flats.
7. Maintain the valve flange alignment while gradually removing the flange-spreaders and tighten the flange bolts hand tight.
8. Slowly close and open the valve to check for adequate disc clearance.
9. Cross tighten all the bolts with the recommended bolt torque shown in Table 1. Do not exceed the maximum bolting torques, as this can lead to overloading of the composite body!

FIGURE 1

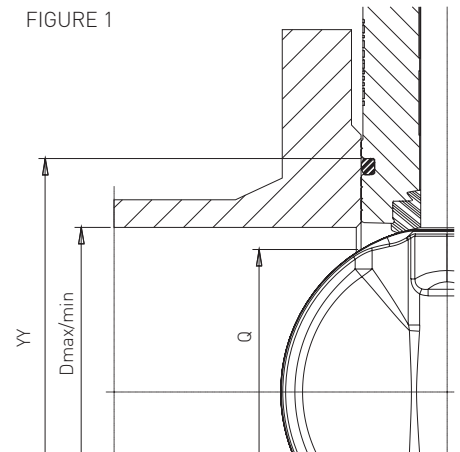
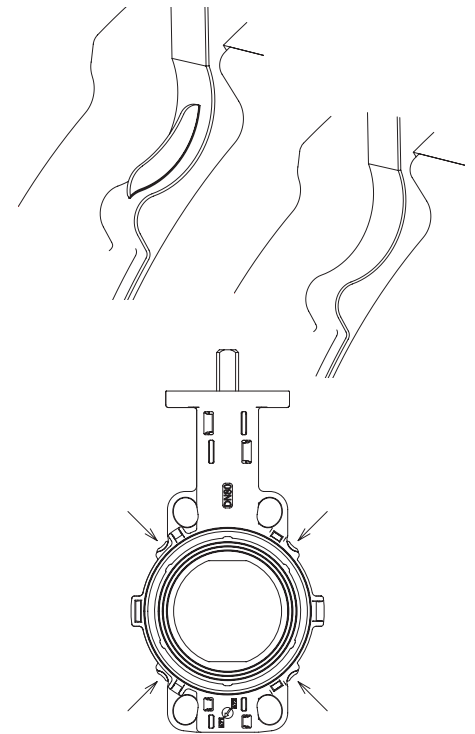

FIGURE 2



KEYSTONE COMPOSEAL BUTTERFLY VALVES, WAFER STYLE

INSTALLATION AND MAINTENANCE INSTRUCTIONS

TABLE 1

Size DN (NPS)	Minimum / Recommended / Maximum flange bolt torque Nm (lbs in)							
	PN 6		PN 10		PN 16		ASME 150	
40 (1.5)	15 / 50 / 60	130/450/550	20 / 55 / 70	180/500/625	20 / 55 / 70	180/500/625	15 / 50 / 60	130/450/550
50 (2)	15 / 50 / 60	130/450/550	20 / 55 / 70	180/500/625	20 / 55 / 70	180/500/625	20 / 55 / 70	180/500/625
65 (2.5)	20 / 55 / 70	180/500/625	30 / 90 / 110	270/800/975	30 / 90 / 110	270/800/975	30 / 90 / 110	270/800/975
80 (3)	30 / 90 / 110	270/800/975	20 / 55 / 70	180/500/625	20 / 55 / 70	180/500/625	30 / 90 / 110	270/800/975
100 (4)	40 / 130 / 160	350/1100/1400	30 / 90 / 110	270/800/975	30 / 90 / 110	270/800/975	30 / 90 / 110	270/800/975
125 (5)	40 / 130 / 160	350/1100/1400	40 / 130 / 160	350/1100/1400	40 / 130 / 160	350/1100/1400	40 / 130 / 160	350/1100/1400
150 (6)	40 / 130 / 160	350/1100/1400	50 / 170 / 210	450/1500/1800	50 / 170 / 210	450/1500/1800	50 / 170 / 210	450/1500/1800
200 (8)	50 / 170 / 210	450/1500/1800	60 / 240 / 300	550/2125/2650	50 / 170 / 210	450/1500/1800	60 / 240 / 300	550/2125/2650
250 (10)	50 / 170 / 210	450/1500/1800	60 / 240 / 300	550/2125/2650	70 / 240 / 300	625/2125/2650	70 / 240 / 300	625/2125/2650
300 (12)	60 / 170 / 210	550/1500/1800	70 / 240 / 300	625/2125/2650	80 / 240 / 300	700/2125/2650	80 / 240 / 300	700/2125/2650

NOTES

Bolt specifications: minimum class 8.8, coarse thread, friction thread and nut-flange friction: 0.14

2.3.2 New system

1. With the disc in near-closed position, center each mating flange with the valve body. Fix the body with some flange bolts and tighten the bolts (do not exceed the maximum tightening moments, see table 1).
2. Use the flange-valve-flange assembly for fit-up and centering to the pipe.
3. Tack-weld the flanges to the pipe.
4. Remove the bolting and remove the valve from between the flanges.
5. Finish-weld the flanges to the pipe and allow the flanges to cool completely.
6. Install the valve according the procedure for installing in the existing system.

IMPORTANT

Do not finish-weld the flanges to the pipe with the valve bolted between the flanges as this will result in serious heat-damage to the composite body and the flange sealing rubber O-ring.

2.4 Valve verification

Check the operation of the valve by operating it from 'fully open' to 'completely closed' position. To verify the valve operation, the disc position indicator on the actuator or the handle should rotate between the 'fully open' and 'completely closed' indicators on the actuator or throttling plate. Generally the valve disc travels clockwise to close.

2.5 Sources of possible danger

2.5.1 Mechanical

When manual operators are used, available space should be checked to prevent the risk of jamming hands.

IMPORTANT

Use pliers to snap-off the nibs and wear eye protection to prevent hand and eye injuries.

2.5.2 Electrical

The composite material can be electrostatically charged by a fluid passing on the in- and/or outside of the valve. When discharging a spark might rise. Behavior of the valve is not different from plastic piping.

2.5.3 Thermal

- A. If the valve is used in applications with a fluid temperature greater than 40°C (104°F) or less than -20°C (-4°F) precautions should be taken to prevent injury from touching the valve outer surface. Also, the handle or operator of the valve might be extreme hot or cold. Personnel should use proper personal protection equipment to prevent injuries. For example: protection gloves.
- B. Hot surfaces can be a potential source of ignition of the environment.

2.5.4 Operational

- A. Closing a valve too fast may result in water hammer in the upstream part of the pipeline. Water hammer results in excessive stresses in the valve and will cause severe damage. Water hammer should be avoided in all circumstances.
- B. A fluid passing the disc of a butterfly valve has the tendency to close the valve disc. Take care when unlatching the valve operating mechanism.

2.6 TROUBLESHOOTING GUIDE

Symptom	Possible cause	Resolution
Valve would not rotate	Actuator has failed	Replace or repair
	Valve packed with debris	Flush or clean valve to remove debris
Valve leaking	Valve not fully closed	Close valve
	Debris trapped in valve	Cycle and flush (with valve open) to remove debris
	Seat is damaged	Replace valve
Jerky operation	Debris trapped in valve	Cycle and flush (with valve open) to remove debris
	Air supply actuator inadequate	Increase air supply pressure and/or volume

KEYSTONE COMPOSEAL BUTTERFLY VALVES, WAFER STYLE

INSTALLATION AND MAINTENANCE INSTRUCTIONS

3 MAINTENANCE

The Keystone CompoSeal is designed to require a minimum of maintenance.

WARNING

Depressurize and, if necessary in case of dangerous fluids, drain the line and flush with appropriate cleaning fluid before starting any maintenance. Failure to do so may cause serious personal injury and/or equipment damage. Before disassembling the valve, ensure the valve has been decontaminated correctly from any harmful gasses or liquids and that it is within a safe temperature range for handling. Personnel making any adjustments to the valves should utilize suitable equipment. All required personal protection means should be worn. Only personnel trained in all aspects of manual and mechanical handling techniques must carry out handling of the valves.

3.1 Routine maintenance

Routine maintenance or lubrication is not required other than periodic inspection to ensure satisfactory operation and sealing.

3.2 Removing the valve

1. Turn the disc to nearly closed position. (The disc is in line with the parallel flats).
2. Loosen all flange bolts and remove the bolts.
3. Spread the flanges with adequate tooling, and remove the valve.

3.3 Valve disassembly

Disassembly is not possible. The body halves are fixed by a one way connection.

Parts identification

- | | |
|---|-----------|
| 1 | Body |
| 2 | Disc stem |
| 3 | Seat |
| 4 | O-ring |

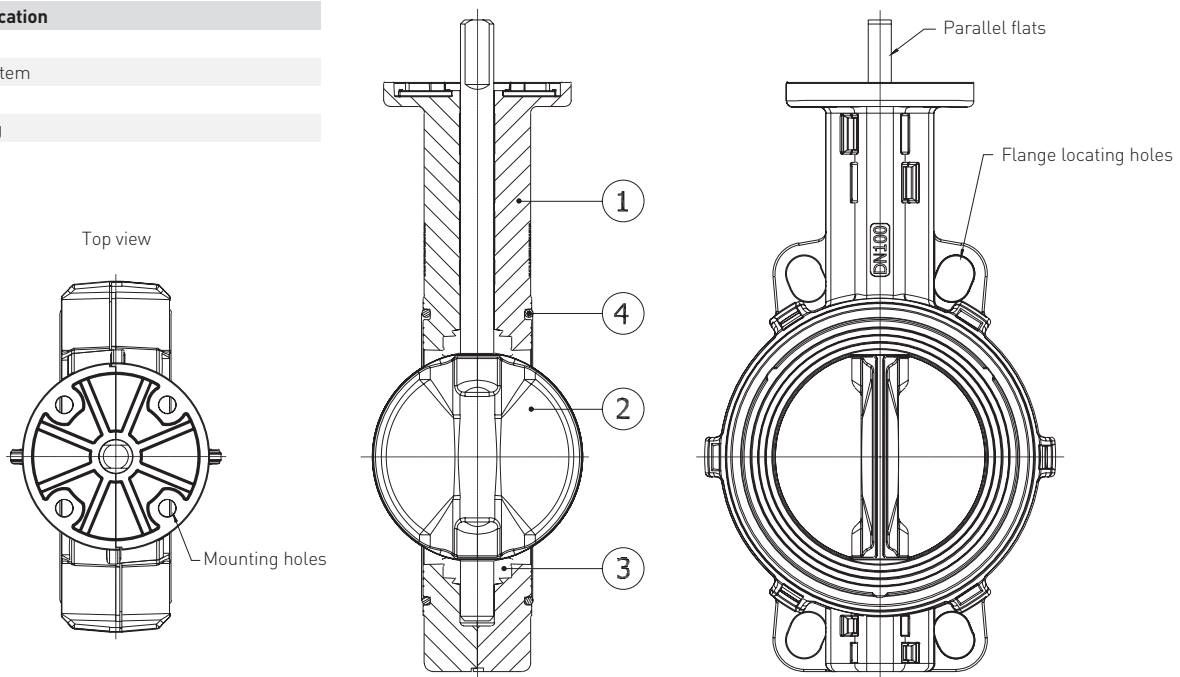

© 2009, 2020 Emerson Electric Co. All rights reserved 08/20. Keystone is a mark owned by one of the companies in the Emerson Automation Solutions business unit of Emerson Electric Co. The Emerson logo is a trademark and service mark of Emerson Electric Co. All other marks are the property of their prospective owners.

The contents of this publication are presented for informational purposes only, and while every effort has been made to ensure their accuracy, they are not to be construed as warranties or guarantees, express or implied, regarding the products or services described herein or their use or applicability. All sales are governed by our terms and conditions, which are available upon request. We reserve the right to modify or improve the designs or specifications of such products at any time without notice.

Emerson Electric Co. does not assume responsibility for the selection, use or maintenance of any product. Responsibility for proper selection, use and maintenance of any Emerson Electric Co. product remains solely with the purchaser.

Emerson.com/FinalControl