

CS200 Series Commercial / Industrial Pressure Reducing Regulators

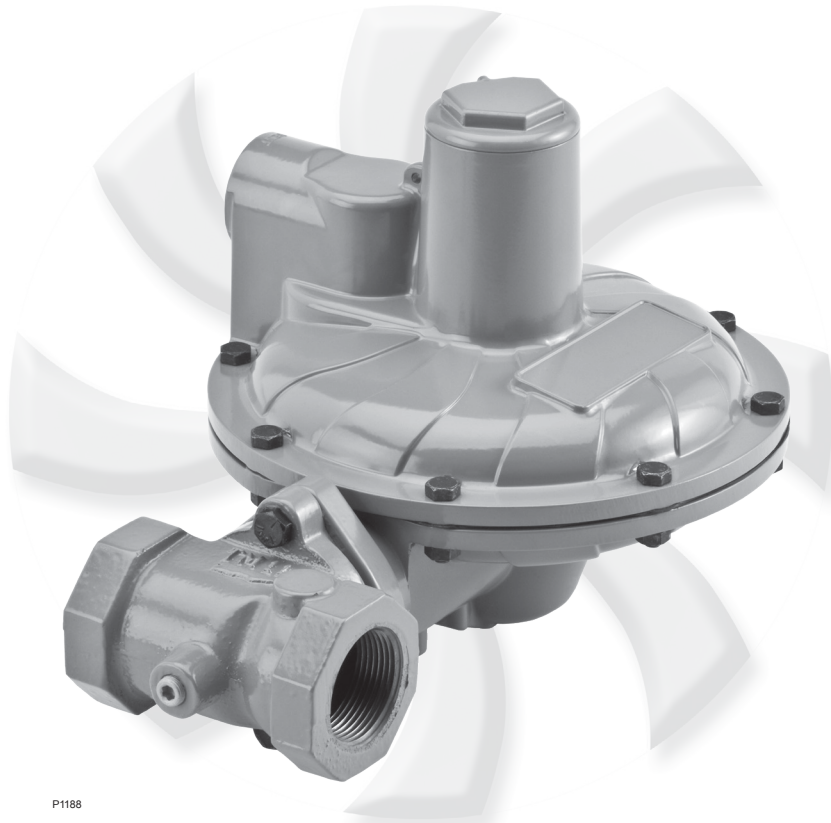

P1188

Figure 1. Typical CS200 Pressure Reducing Regulator

Table of Contents

Introduction	1
Specifications	3
Principle of Operation	4
Installation and Overpressure Protection	6
Startup	7
Adjustment	8
Shutdown	8
Maintenance	8
Parts Ordering	9
Parts List	9

Introduction

Scope of the Manual

This manual provides instructions for the installation, maintenance, and parts ordering information for Types CS200IN, CS200IR, CS205IN, CS205IR, and CS206IR service regulators.



CS200 Series

Table 1. Available Configurations

TYPE NUMBER					OPTIONS		
C	S	2	0				
							OVERPRESSURE PROTECTION MODULE
				0			Without Overpressure Protection Module
				5			With Secondary Seat™ Protection
				6			With Secondary Seat Protection with bleed to indicate Secondary Seat is functioning
							PRESSURE REGISTRATION
					I		Internal Registration
							RELIEF
						N	Non-Relief
						R	Internal Relief

Table 2. Inlet Pressure Ratings and Flow and Sizing Coefficients

TYPE	ORIFICE SIZE		MAXIMUM OPERATING INLET PRESSURE TO PROVIDE OPTIMUM PERFORMANCE ⁽¹⁾⁽²⁾		MAXIMUM EMERGENCY INLET PRESSURE ⁽²⁾		FLOW COEFFICIENTS (WIDE-OPEN)		C _i	IEC SIZING COEFFICIENTS			
	Inch	mm	psig	bar	psig	bar	C _g	C _v		X _T	F _D	F _L	
CS200	1/8	3.2	125	8.6	175	12.1	12	0.4	30	0.53	0.87	0.89	
	3/16	4.8	125	8.6			24	0.8		30	0.58		0.82
	1/4	6.4	125	8.6			44	1.52		29	0.53		0.85
	3/8	9.5	60	4.1			102	3.3		31	0.6		0.83
	1/2	13	40	2.8			172	4.4		39	0.97		0.72
CS205 and CS206	1/8	3.2	125	8.6	175	12.1	17	0.6	28	0.5	0.82	0.89	
	3/16	4.8	125	8.6			37	1.4		27	0.49		0.8
	1/4	6.4	125	8.6			65	2.2		30	0.5		0.8
	5/16	7.9	100	6.9			88	2.7		33	0.65		0.79

1. Inlet pressures based on lockup performance. For maximum inlet pressure values with optimum regulating performance, refer to the applicable Flow Capacity Table on CS200 Series Bulletin.
 2. To comply with ANSI B109.4 relief requirements, the maximum inlet pressure may need to be reduced.



WARNING

Failure to follow these instructions or to properly install and maintain this equipment could result in an explosion and/or fire causing property damage and personal injury or death.

Fisher® regulators must be installed, operated, and maintained in accordance with federal, state, and local codes, rules and regulations, and Emerson Process Management Regulator Technologies, Inc. (Regulator Technologies) instructions.

If the regulator vents gas or a leak develops in the system, service to the unit may be required. Failure to correct trouble could result in a hazardous condition.

Call a gas service person to service the unit. Only a qualified person shall install or service the regulator.

Description

The CS200 Series regulators are typically installed on industrial and commercial applications. All constructions include internal pressure registration. Types CS200IR, CS205IR, and CS206IR contain an internal relief valve. Types CS200IN and CS205IN do not contain internal relief.

Specifications

The Specifications section lists the specifications for the regulators. The following information is stamped on the regulator at the factory: type number, date of manufacture, spring range, orifice size, maximum inlet pressure, maximum operating outlet pressure, and outlet pressure which may damage regulator parts.

<p>Available Configurations</p> <p>Type CS200IN: Basic construction with Internal pressure registration and Non-Relieving diaphragm assembly</p> <p>Type CS200IR: Basic construction with Internal pressure registration and Relieving diaphragm assembly</p> <p>Type CS205IN: Type CS200IN with Secondary Seat™ Protection</p> <p>Type CS205IR: Type CS200IR with Secondary Seat Protection</p> <p>Type CS206IR: Type CS200IR with Secondary Seat Protection with bleed to indicate that the Secondary Seat is providing lockup See also Table 1</p> <p>Body Sizes, End Connection Style, and Pressure Rating⁽¹⁾ See Table 4</p> <p>Outlet Pressure Ranges See Table 3</p> <p>Spring Case Vent Connection 1 NPT</p>	<p>Orifice Sizes See Table 2</p> <p>Flow and IEC Sizing Coefficients See Table 2</p> <p>Maximum Inlet Pressures⁽¹⁾ Emergency: 175 psig / 12.1 bar Operating: See Table 2</p> <p>Maximum Outlet Pressures⁽¹⁾ Casing: 25 psig / 1.7 bar To Avoid Internal Parts Damage: 5 psi / 0.34 bar differential above outlet pressure setting Operating: 2 psig / 138 mbar</p> <p>Temperature Capabilities⁽¹⁾⁽²⁾ -20 to 150°F / -29 to 66°C</p> <p>Pressure Registration Internal</p> <p>Approximate Weight 8 pounds / 3.6 kg</p>
--	---

1. The pressure/temperature limits in this Instruction Manual and any applicable standard or code limitation should not be exceeded.
 2. Product has passed Regulator Technologies testing for lockup, relief start-to-discharge and reseal down to -40°.

Table 3. Outlet Pressure Ranges

SERIES	SPRING RANGE		PART NUMBER	COLOR CODE	SPRING WIRE DIAMETER		SPRING FREE LENGTH	
	Inches w.c.	mbar			Inch	mm	Inch	mm
CS200	3.5 to 5	9 to 12	GE30198X012	Red	0.102	2.59	3.95	100
	4.5 to 6.5	11 to 16	GE30195X012	Purple	0.090	2.28	4.32	110
	6 to 8	15 to 20	GE30188X012	Gold	0.111	2.82	4.48	114
	7.5 to 11	19 to 27	GE30189X012	Blue	0.112	2.84	4.40	112
	10 to 14	25 to 35	GE30224X012	Unpainted	0.102	2.59	4.78	121
	12 to 19	30 to 47	GE30196X012	Green	0.112	2.84	4.40	112
	18 to 1 psig	45 to 69	GE30225X012	Orange	0.120	3.04	4.94	125
	1 to 2 psig	69 to 138	GE30190X012	Black	0.145	3.68	4.66	118

Table 4. Body Sizes, Material, End Connection, and Pressure Rating

SERIES	BODY SIZE, NPS	END CONNECTION	BODY MATERIAL	PRESSURE RATING	
				psig	bar
CS200	3/4 3/4 x 1 3/4 x 1-1/4 1 1 x 1-1/4 1-1/4	NPT	Gray Cast Iron	175	12.1

CS200 Series

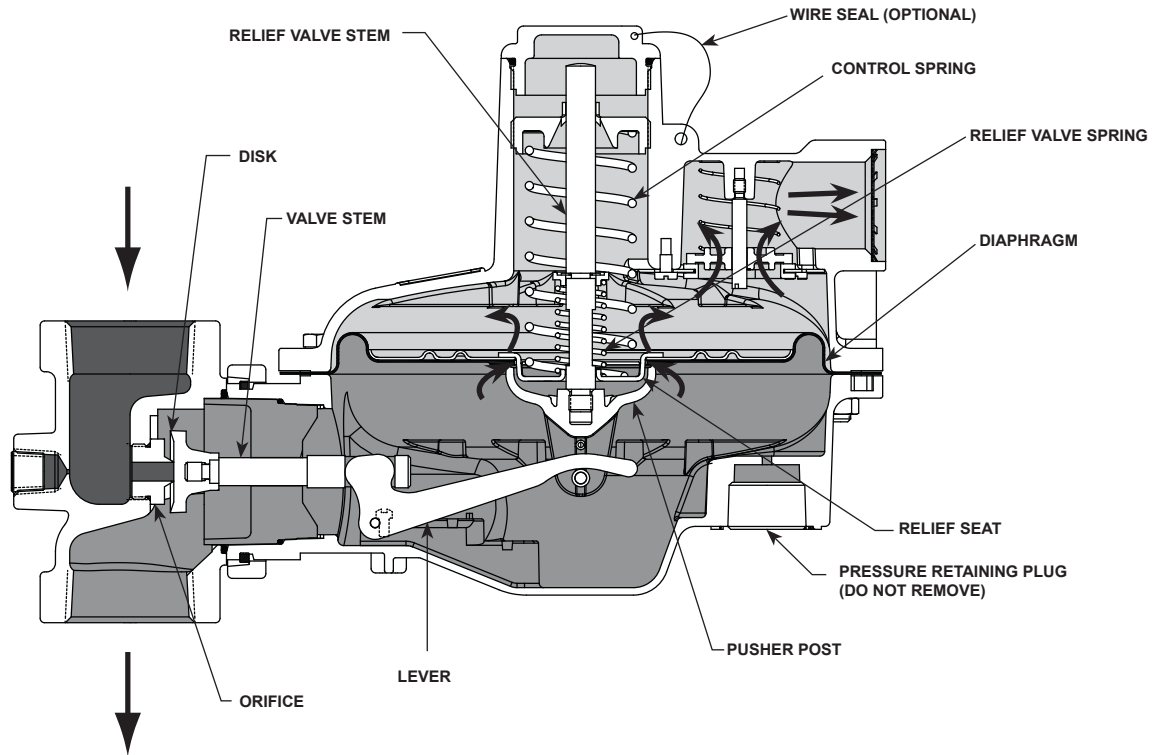

ERAA03487

Figure 2. Type CS200IR Pressure Reducing Regulator with Internal Relief Operational Schematic

Principle of Operation

Type CS200 Base Regulator Operation

Refer to Figure 2. When downstream demand decreases, the pressure under the diaphragm increases. This pressure overcomes the regulator setting (which is set by the control spring). Through the action of the pusher post assembly, lever, and valve stem, the valve disk moves closer to the orifice and reduces gas flow. If demand downstream increases, pressure under the diaphragm decreases. Spring force pushes the pusher post assembly downward and the valve disk moves away from the orifice.

CS200 Series with Internal Relief

Refer to Figure 2. The option for Internal Relief is offered on the Types CS200 and CS205 and is standard on the Type CS206. Internal relief is used to help minimize overpressure. Any outlet pressure above the start-to-discharge point of the non-adjustable relief spring moves the diaphragm off of the relief seat, allowing excess pressure to discharge through the vent. Typical start-to-discharge values are 7 inches w.c. to 1.5 psi / 17 to 103 mbar above the outlet pressure setting, depending on control spring and if the Secondary Seat™ option is present. Refer to Table 5 for Type CS205 lockup values and Type CS206 downstream build-up values. Refer to the CS200 Series Bulletin for additional information regarding Internal Relief start-to-

discharge both with and without Secondary Seat Protection. If emergency conditions should exist that prevent normal operation of the regulator or internal relief valve, the relief valve stem acts as a secondary travel stop contacting the underside of the closing cap and stopping the upward travel of the relief seat. When the diaphragm continues to rise as downstream pressure builds, the diaphragm lifts off of the relief seat to provide relief operation.

Type CS205 with Secondary Seat Protection

Refer to Figure 3. The Type CS205 provides Secondary Seat Protection. As downstream demand decreases and downstream pressure rises to the regulator pressure lockup value, the regulator will lock up. If, however, damage has occurred to the primary disk, to the primary orifice's seating surface, or debris has become lodged between the primary disk and primary orifice, the outlet pressure will continue to rise. This additional pressure causes the primary disk to apply additional force to the orifice seating surface, which causes the Secondary seating surface to move toward the Secondary disk or sealing surface. If downstream demand decreases to zero, then the secondary seating surface will contact the sealing surface to provide lockup. Refer to Table 5 for approximate lockup values provided by the Secondary Seat.

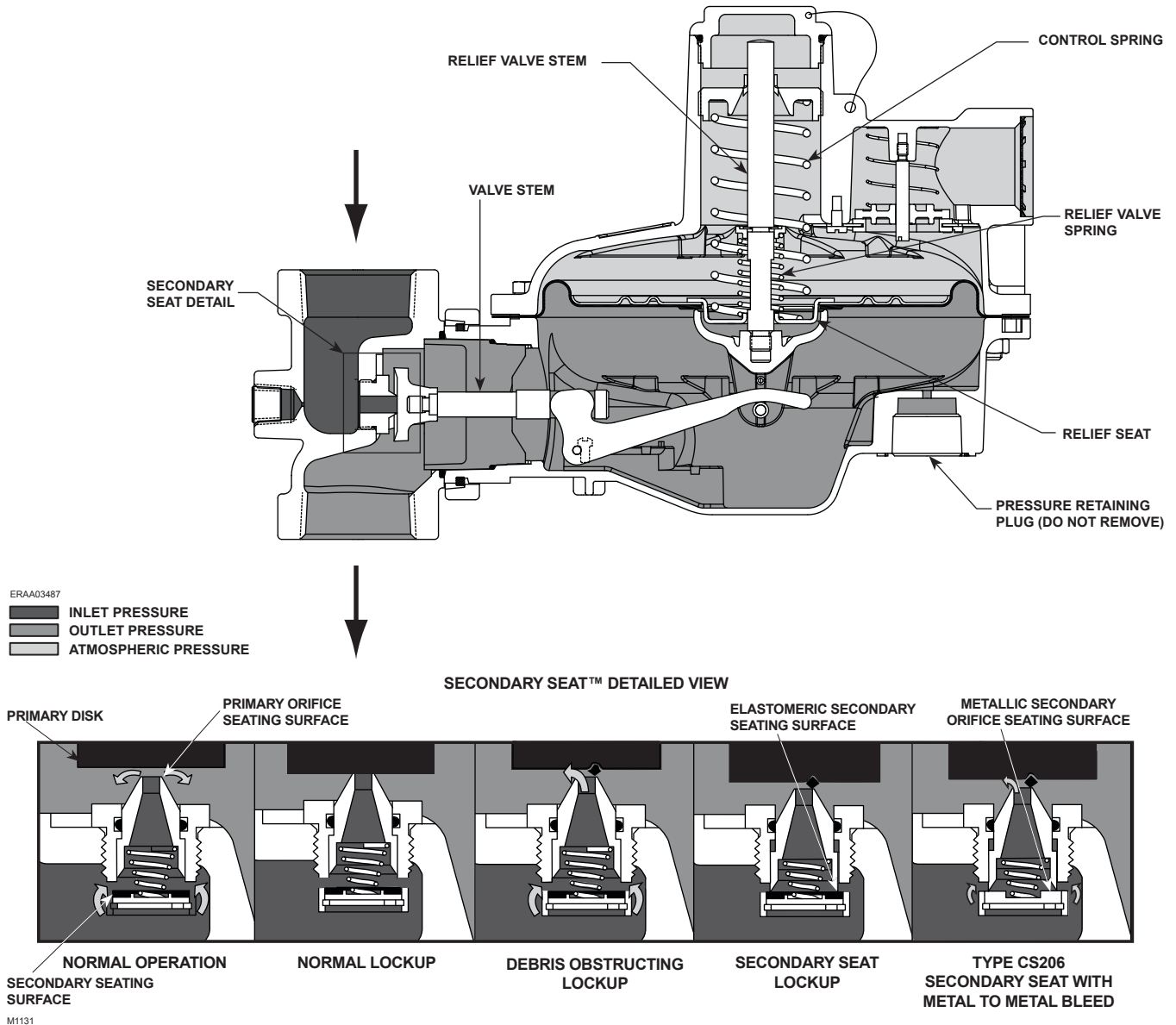

Figure 3. CS200 Series with Secondary Seat Protection

Type CS206 Secondary Seat Protection with Bleed

The Type CS206 provides small bleed to the downstream system as an indication that the Secondary Seat is providing lockup. In the event that the primary orifice and disk cannot provide lockup, the secondary seating surface will move into contact with a metal disk. This metal to metal interface will allow a small amount of gas to bleed downstream thereby increasing outlet pressure until the Internal relief valve begins to discharge gas to the atmosphere. The odor of this discharged gas provides an indication that the regulator is relying on the Secondary Seat for overpressure protection. See Table 5 for the Downstream Pressure Build-up of the

Internal relief acting in conjunction with the Type CS206 Secondary Seat Assembly.

Types CS205 and CS206 Secondary Seat Protection Limitations

CAUTION

Overpressure conditions can occur in the downstream piping when the Secondary Seat Protection is installed. The Secondary Seat Protection serves only as a backup to the primary seat for lockup. Refer to the sections on Overpressure Protection and Maintenance.

CS200 Series

Table 5. Secondary Seat™ Outlet Pressures

CONTROL SPRING		SPRING RANGE		SETPOINT		TYPE CS205		TYPE CS206	
						Secondary Seat Shut-off above Setpoint ⁽¹⁾⁽²⁾		Downstream Pressure Build-up	
Color	Part Number	Inch w.c.	mbar	Inch w.c.	mbar	Inch w.c.	mbar	Inch w.c.	mbar
Gold	GE30188X012	6 to 8	15 to 20	7	17	5	12	25.1	62
Blue	GE30189X012	7.5 to 11	19 to 27	11	27	5.5	14	29.6	74
Unpainted	GE30224X012	10 to 14	25 to 35	14	35	5.8	14	1.26 psig	87
Orange	GE30225X012	18 to 1 psig	45 to 69	1 psig	69	7.8	19	1.90 psig	131
Black	GE30190X012	1 to 2 psig	69 to 138	2 psig	138	13	32	3.42 psig	236

1. Shutoff with primary orifice / seating surface disabled.
 2. Shutoff and build-up per ANSI B109.4 at 125 psig / 8.6 bar inlet pressure.

Secondary Seat Protection does not provide additional overpressure protection in the event the secondary seat or disk is damaged by debris or contamination in the pipeline, or from conditions that would cause the regulator to go wide-open. When selecting Secondary Seat Protection, it is recommended that:

- Internal Relief is also selected, or the addition of some other method of overpressure protection be added in the downstream system as discussed in the Overpressure Protection section; and
- A periodic downstream lock-up pressure test is done to determine if the Secondary Seat Protection option is serving as the primary seat for shutoff, thereby indicating that the primary orifice/seat or the disk are no longer providing shutoff. This determination is made by checking if the regulator lock-up value is elevated to or near the values indicated in Table 5, under the heading Type CS205

Installation and Overpressure Protection

WARNING

Personal injury or system damage may result if this regulator is installed, without appropriate overpressure protection, where service conditions could exceed the limits given on the regulator nameplate.

Regulator installations should be adequately protected from physical damage.

All vents should be kept open to permit free flow of gas to the atmosphere. Protect openings against entrance of rain, snow, insects, or any other foreign material that may plug the vent or vent line. On

outdoor installations, point the spring case vent downward to allow condensate to drain (see Figure 4). This minimizes the possibility of freezing and of water or other foreign materials entering the vent and interfering with proper operation.

Under enclosed conditions or indoors, escaping gas may accumulate and be an explosion hazard. In these cases, the vent should be piped away from the regulator to the outdoors.

CAUTION

The CS200 Series regulators have an outlet pressure rating lower than their inlet pressure rating. If actual inlet pressure can exceed the outlet pressure rating, outlet overpressure protection is necessary. However, overpressuring any portion of the regulators beyond the limits in the Specifications section may cause leakage, damage to regulator parts, or personal injury due to bursting of pressure-containing parts.

Some type of external overpressure protection should be provided if inlet pressure will be high enough to damage downstream equipment. Common methods of external overpressure protection include relief valves, monitoring regulators, shutoff devices, and series regulation.

If the regulator is exposed to an overpressure condition, it should be inspected for any damage that may have occurred. Regulator operation below these limits does not preclude the possibility of damage from external sources or from debris in the pipeline.

General Installation Instructions

Before installing the regulator,

- Check for damage, which might have occurred during shipment.
- Check for and remove any dirt or foreign material, which may have accumulated in the regulator body.
- Blow out any debris, dirt or copper sulfate in copper tubing and the pipeline.
- Apply pipe compound to the external threads of the pipe before installing the regulator.
- Make sure gas flow through the regulator is in the same direction as the arrow on the body. "Inlet" and "Outlet" connections are clearly marked.

Installation Location

- The installed regulator should be adequately protected from vehicular traffic and damage from other external sources.
- **Install the regulator with the vent pointed vertically down, see Figure 4.** If the vent cannot be installed in a vertically down position, the regulator must be installed under a separate protective cover. Installing the regulator with the vent down allows condensation to drain, minimizes the entry of water or other debris from entering the vent, and minimizes vent blockage from freezing precipitation.
- **Do not install the regulator in a location where there can be excessive water accumulation or ice formation,** such as directly beneath a downspout, gutter, or roof line of building. Even a protective hood may not provide adequate protection in these instances.
- Install the Regulator so that any gas discharge through the vent or vent assembly is over 3 feet / 0.91 m away from any building opening.

Regulators Subjected to Heavy Snow Conditions

Some installations, such as in areas with heavy snowfall, may require a hood or enclosure to protect the regulator from snow load and vent freeze over.

Installation with External Overpressure Protection

If the regulator is used in conjunction with a Type 289H relief valve, it should be installed as shown in Figure 4. The outside end of the vent line should be protected with a rainproof assembly.

The Type 289H is typically set 10-inches w.c. / 25 mbar higher than the outlet pressure setting of the regulator, up to 30 inches w.c. / 75 mbar outlet pressure. For pressure greater than this, set the Type 289H 0.75 psi / 0.05 bar higher than the outlet pressure setting of the regulator.

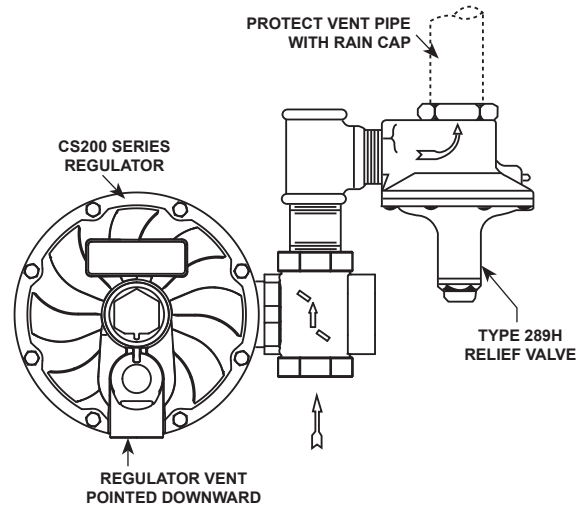

Figure 4. CS200 Series Regulator Installed with Vent Pointed Downward and with a Type 289H Relief Valve for High Capacity Relief

Vent Line Installation

The CS200 Series regulators have a 1 NPT screened vent opening in the spring case. If necessary to vent escaping gas away from the regulator, install a remote vent line in the spring case tapping. Vent piping should be as short and direct as possible with a minimum number of bends and elbows. The remote vent line should have the largest practical diameter. Vent piping on regulators with internal relief must be large enough to vent all relief valve discharge to atmosphere without excessive backpressure and resulting excessive pressure in the regulator.

Periodically check all vent openings to be sure that they are not plugged or obstructed.

Outlet pressure ranges are shown on Table 3. Outlet pressure greater than 5 psi / 0.34 bar above the setpoint may damage internal parts such as the diaphragm head and valve disk. **The maximum emergency (casing) outlet pressure is 25 psig / 1.7 bar.**

Startup



CAUTION

Pressure gauges must always be used to monitor downstream pressure during startup. Procedures used in putting this regulator into operation must be planned accordingly if the downstream system is pressurized by another regulator or by a manual bypass.

CS200 Series

If the downstream system is not pressurized by another regulator or manual bypass valve, use the following procedure to startup the regulator.

1. Check to see that all appliances are turned off.
2. Slowly open the upstream shutoff valve.
3. Check inlet and outlet pressure for correct values.
4. Check all connections for leaks.
5. Turn on utilization equipment and recheck the pressures.

Adjustment

Note

The range of allowable pressure setting is stamped on the nameplate. If the required setting is not within this range, substitute the correct spring (as shown in Table 3). If the spring is changed, change the nameplate to indicate the new pressure range.

A pressure gauge must always be used to monitor downstream pressure while adjustments are being made.

1. Remove the closing cap (key 60, Figure 5).
2. To increase the outlet setting, turn the adjusting screw (key 65, Figure 5) clockwise. To decrease the outlet setting, turn the adjusting screw counterclockwise.
3. Replace the closing cap.

Shutdown

Installation arrangements may vary, but in any installation it is important that the valves be opened or closed slowly and that the outlet pressure be vented before venting inlet pressure to prevent damage caused by reverse pressurization of the regulator. The steps below apply to the typical installation as indicated.

1. Open valves downstream of the regulator.
2. Slowly close the upstream shutoff valve.
3. Inlet pressure should be automatically released downstream as the regulator opens in response to the lowered pressure on the diaphragm.
4. Close outlet shutoff valve.

Maintenance



WARNING

To avoid personal injury or equipment damage, do not attempt any maintenance or disassembly without first isolating the regulator from system pressure and relieving all internal pressure as described in “Shutdown”.

Regulators that have been disassembled for repair must be tested for proper operation before being returned to service. Only parts manufactured by Regulator Technologies should be used for repairing Fisher® regulators. Restart gas utilization equipment according to normal startup procedures.

Due to normal wear or damage that may occur from external sources, this regulator should be inspected and maintained periodically. The frequency of inspection and replacement of parts depends upon the severity of service conditions or the requirement of local, state, and federal rules and regulations.

Maintenance on Types CS205 and CS206 Secondary Seat™ Protection

The Type CS205 regulator does not have any means to alert when the Secondary Seat operates at lockup. Therefore it is recommended that a periodic lockup test be done on the regulator to determine if the lockup pressure has elevated to the values in Table 5. If so, the regulator primary disk and orifice should be replaced.

Types CS205IR and CS206IR have internal relief. Internal relief operation on these units is an indication that the Secondary Seat Protection on the Type CS205IR may not be working and that the Type CS206 Secondary Seat may have closed. Maintenance should address any potential causes for internal relief operation as well as other regulator malfunctions separate from the Secondary Seat.

Disassembly to Replace Diaphragm

1. Remove the closing cap (key 60, Figure 5). Turn the adjusting screw (key 65) counterclockwise to ease spring compression.
2. Remove the adjusting screw and spring (key 38).
3. Remove hex nuts (key 16) and cap screws (key 15). Separate the upper spring case (key 1) from the lower casing assembly (key 9). Note vent orientation.

Note

When disassembling a CS200 Series regulator, lift the upper spring case straight up in order to avoid hitting the relief valve stem (key 44, Figure 5).

4. Slide the diaphragm assembly (key 55) away from the body (key 70) to unhook the pusher post (key 51) from the lever (key 10). Lift off the diaphragm head assembly (key 55).
5. **For Types CS200IN and CS205IN (Non-relieving units)**, unscrew the retainer screw (key 45, Figure 6) using a 5/8-inch / 16 mm wrench. The screw retainer

fastens the lower spring seat (key 43) to the pusher post (key 51). Unscrewing the screw retainer will separate the lower spring seat (key 43), diaphragm and diaphragm assembly (key 55), and pusher post (key 51).

For Type CS200IR, CS205IR, and CS206IR (units with internal relief), press down on the upper spring retainer (key 42, Figure 6) using a 9/16-inch / 14 mm box-end wrench and remove the retaining ring (key 58). Slide the upper spring retainer (key 42), the relief spring (key 41), the lower spring seat (key 43) and the diaphragm assembly (key 55) off of the relief valve stem (key 44).

6. Reassemble regulator in the reverse order of the above steps.

Disassembly to Replace Valve Disk and Orifice

1. Remove the bolts (key 71, Figure 5) which hold the lower spring casing (key 9) to the body (key 70). Separate the lower spring casing from the body.
2. Check the body O-ring (key 21) for wear and replace as necessary.
3. Examine the valve disk (key 36, Figure 5) for nicks, cuts, and other damage. Remove the disk by pulling and replace it with a new part if necessary.
4.
 - a. If the seating edge of the Type CS200 orifice (key 25, Figure 7) is nicked or rough, remove the orifice from the body using a 7/8-inch / 22 mm socket wrench.
 - b. If equipped with a Type CS205/206 Secondary Seat™ orifice assembly, inspect the primary seating surface as well as the secondary seating surface and sealing surface. If nicks or other damage are present, remove the orifice assembly from the body using a 7/8-inch / 22 mm socket wrench.

Apply anti-seize lubricant to the external threads of the new orifice and reassemble.

Note

If the orifice is being replaced with a different size, change the nameplate to state the new size and maximum inlet pressure.

5. Reassemble the regulator in reverse order of the above steps.

Regulator Reassembly

It is recommended that a good quality pipe thread sealant be applied to pressure connections and fittings and a good quality lubricant be applied to all O-rings except when replacing key 19, as key 19 is a friction fit O-ring for

holding the stem guide into the lower casing. Also apply an anti-seize compound to the adjusting screw threads and other areas as needed. Refer to Figures 5 through 7.

Parts Ordering

The type number, orifice size, spring range, and date of manufacture are stamped on the nameplate. Always provide this information in any correspondence with your local Sales Office regarding replacement parts or technical assistance.

When ordering replacement parts, reference the key number of each needed part as found in the following parts list. Separate kit containing all recommended spare parts is available.

Parts List

Key	Description	Part Number
	Spare Parts (Repair Parts Kit includes keys 21, 36, 55, and 62)	
	Type CS200	RCS200X0012
1	Upper Case, Aluminum	GE24555X012
2	Vent Screen, 18-8 Stainless steel	T1121338982
3	Retaining Ring, Zinc-plated steel	T1120925072
4	Stabilizer Guide, Stainless steel	GE27061X012
5	Stabilizer, 1 inch / 25 mm	GE27063X012
6	Spring, Stainless steel	GE35010X012
7	Retainer Plate, Zinc-plated steel	GE27024X012
8	Stabilizer Screw, Zinc-plated steel (3 required)	GE29724X012
9	Lower Casing, Aluminum	GE24289X012
10	Lever, Steel	GE27194X012
11	Stem, Aluminum	GE27439X012
13	Lever Pin, Stainless steel	T14397T0012
14	Lever Screw, Steel (2 required)	GE34243X012
15	Cap Screw, Steel (8 required)	GE32059X012
16	Nut, Steel (8 required)	GE32060X012
17	Union Ring, Aluminum	GE26591X012
18	Snap Ring, Stainless steel	T1120637022
19*	O-ring, Nitrile (NBR)	1K594906562
20	Stem Guide, Aluminum	GE31962X012
21*	O-ring, Nitrile (NBR)	GE45216X012
22*	Pipe Plug, Steel, 3/4 NPT	GE34199X012
25*	Orifice Assembly	
	Type CS200 without Secondary Seat™ protection, Aluminum	
	1/8 inch / 3.1 mm	1A936709012
	3/16 inch / 4.7 mm	00991209012
	1/4 inch / 6.4 mm	0B042009012
	3/8 inch / 9.5 mm	0B042209012
	1/2 inch / 13 mm	1A928809012
	Type CS205 with Secondary Seat protection, Brass/Nitrile (NBR)	
	1/8 inch / 3.1 mm	GE31991X012
	3/16 inch / 4.7 mm	GE32008X012
	1/4 inch / 6.4 mm	GE32010X012
	5/16 inch / 7.9 mm	GE32012X012
	Type CS206 with Secondary Seat protection and bleed, Brass/Nitrile (NBR)	
	1/8 inch / 3.1 mm	GE32007X012
	3/16 inch / 4.7 mm	GE32009X012
	1/4 inch / 6.4 mm	GE32011X012
	5/16 inch / 7.9 mm	GE32014X012

*Recommended spare part.

CS200 Series

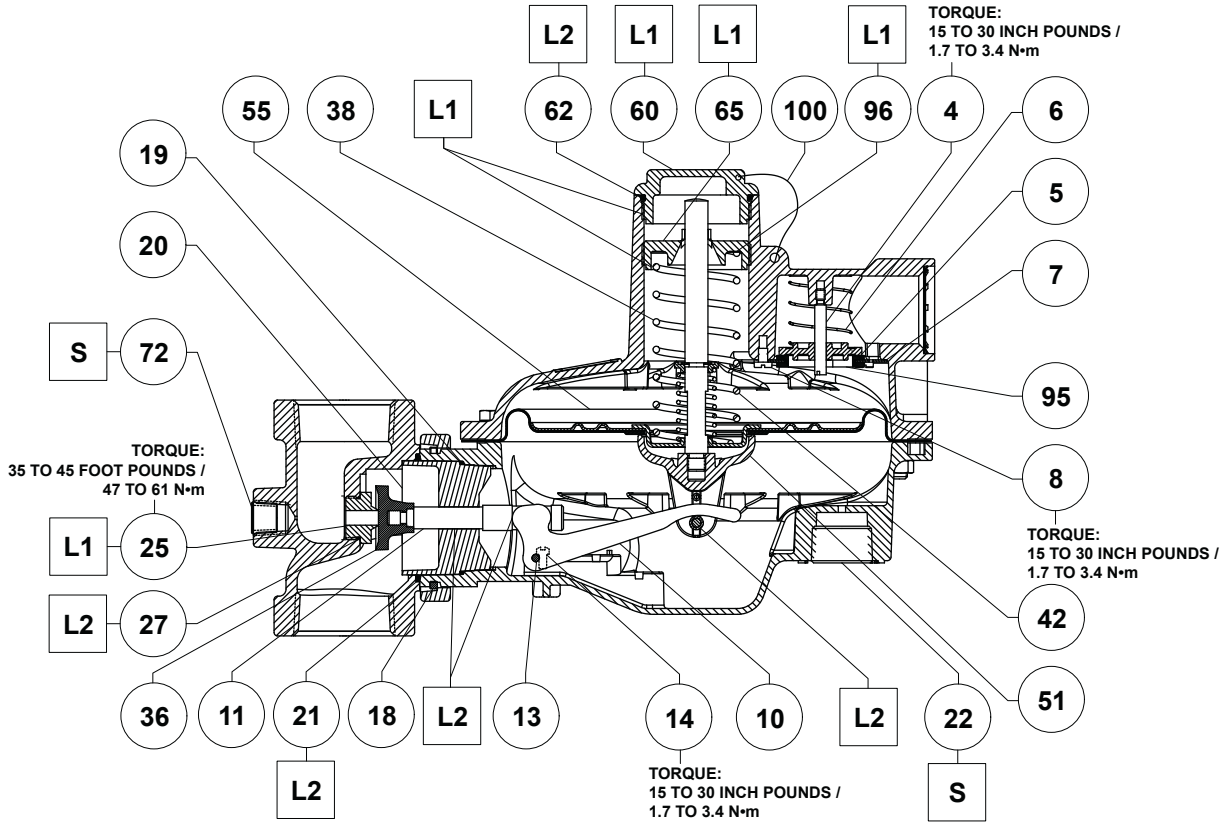

MAIN VALVE

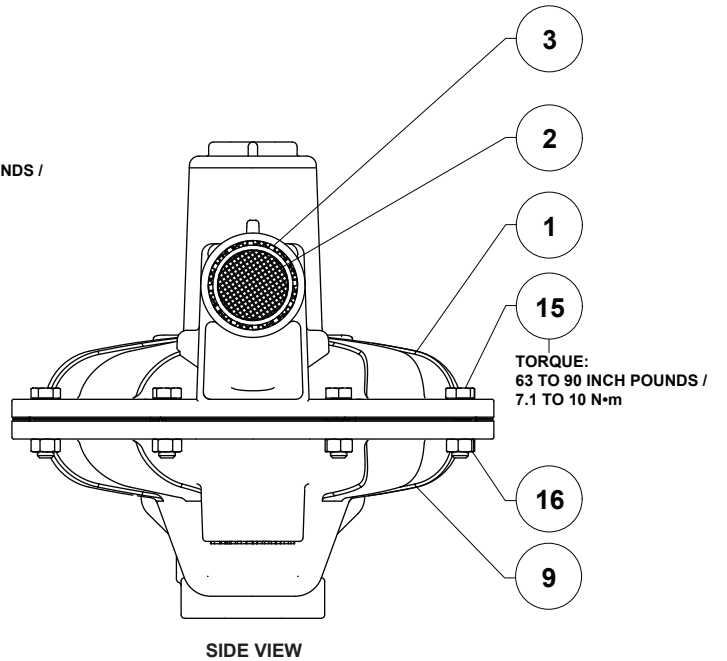
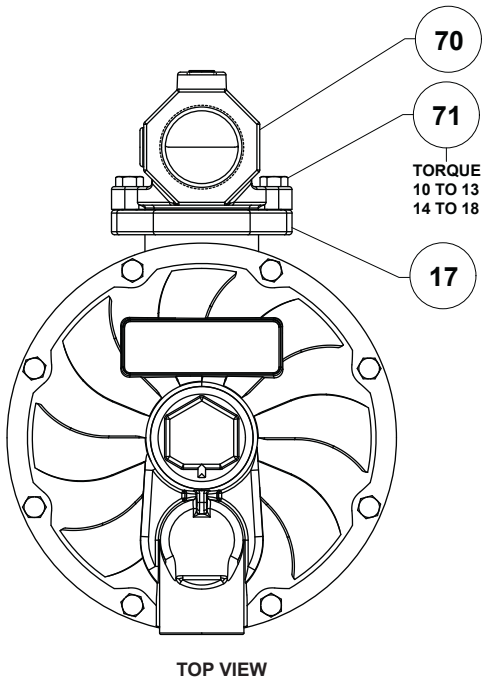

ERAA03487

- APPLY LUBRICANT (L) / SEALANT (S)⁽¹⁾
- L1 = ANTI-SEIZE LUBRICANT
- L2 = SILICON GREASE
- S = THREAD SEALANT

1. Lubricants and sealants must be selected such that they meet the temperature requirements.

Figure 5. CS200 Series Pressure Reducing Regulator Assemblies

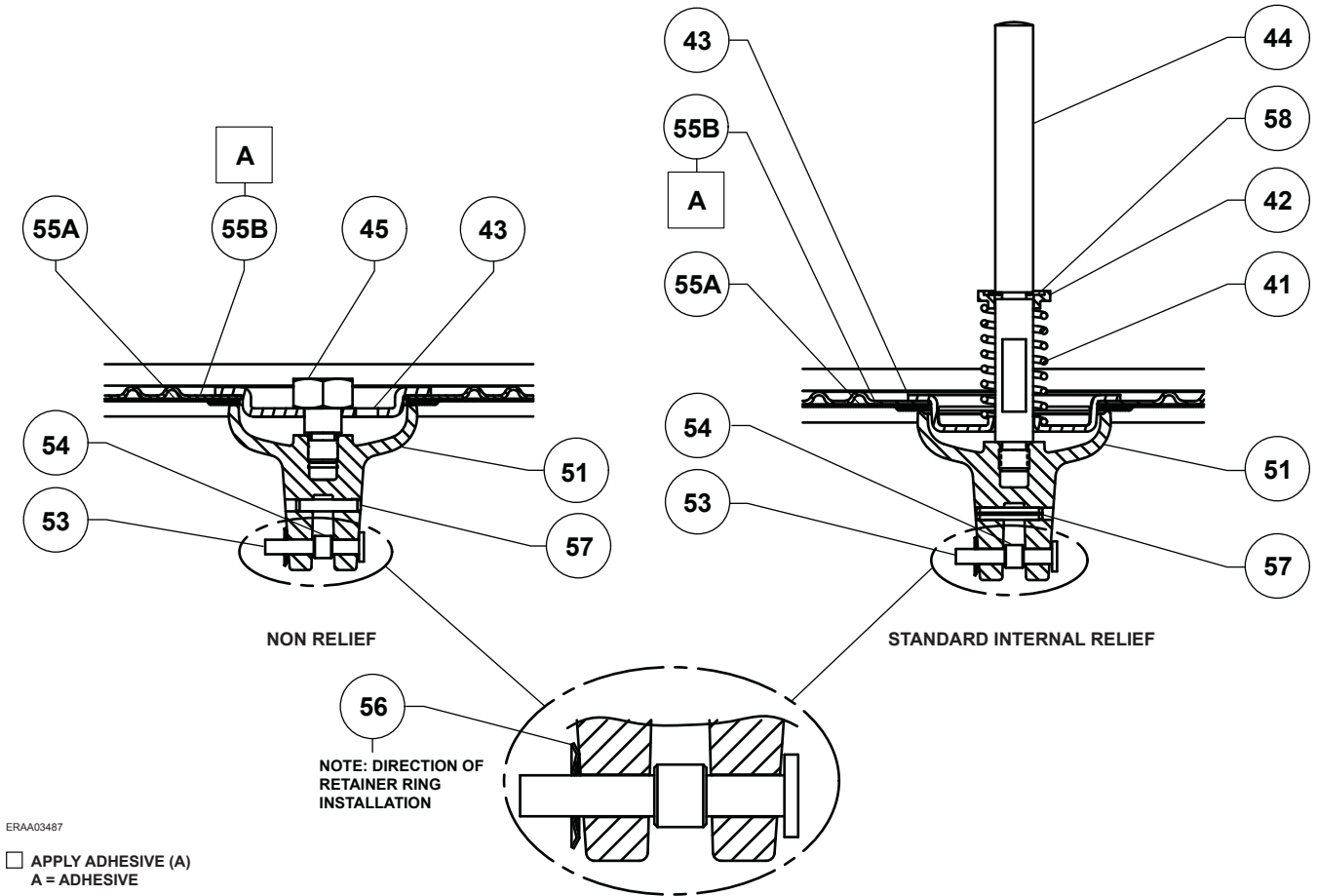
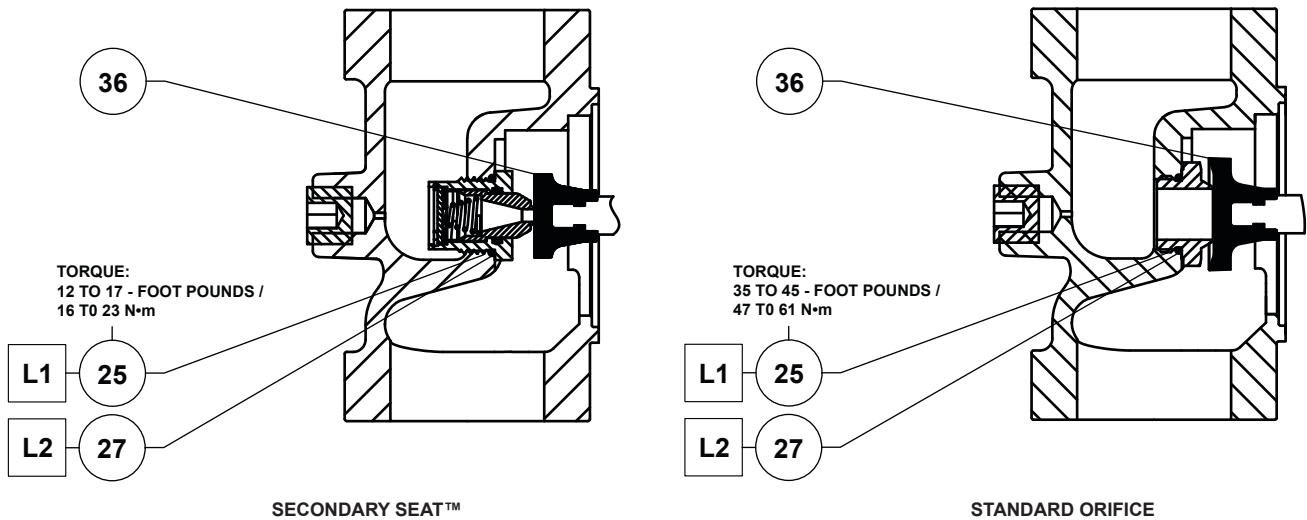

Figure 6. CS200 Series Diaphragm Assemblies



1. Lubricants must be selected such that they meet the temperature requirements.

Figure 7. CS200 Series Orifice Assemblies

CS200 Series

Parts List (continued)

Key	Description	Part Number	Key	Description	Part Number
27*	O-ring, Nitrile (NBR)	11A8741X052	53	Post Pin, Stainless steel	GE29761X012
36*	Disk, Nitrile (NBR) Type C200 Types CS205 and CS206	GE38132X012 GG01395X012	54	Roller Pin, Brass	GE27060X012
38	Spring, Stainless steel or Music wire 3.5 to 5 inches w.c. / 9 to 12 mbar, Red 4.5 to 6.5 inches w.c. / 11 to 16 mbar, Purple 6 to 8 inches w.c. / 15 to 20 mbar, Gold 7.5 to 11 inches w.c. / 19 to 27 mbar, Blue 10 to 14 inches w.c. / 25 to 35 mbar, Unpainted 12 to 19 inches w.c. / 30 to 47 mbar, Green 18 inches w.c. to 1 psig / 45 to 69 mbar, Orange 1 to 2 psig / 69 to 138 mbar, Black	GE30198X012 GE30195X012 GE30188X012 GE30189X012 GE30224X012 GE30196X012 GE30225X012 GE30190X012	55*	Diaphragm Assembly, Steel/Nitrile (NBR)	GE31248X012
41	Relief Spring, Stainless steel	GE30194X012	56	Retaining Ring, Pusher Post Pin, Steel	GE33772X012
42	Upper Spring Retainer, Aluminum	GE27296X012	57	Slotted Spring Pin, Zinc-plated steel	GE33668X012
43	Spring Seat, Zinc-plated steel Non-Relief Relief	GE27327X012 GE28947X012	58*	E-Ring, Copper	GE32969X012
44	Relief valve stem, Aluminum	GE27297X012	60	Closing Cap, Aluminum	GE29244X012
45*	Diaphragm Screw retainer, Zinc-plated steel	GE30887X012	62*	O-ring, Nitrile (NBR)	T10275X0012
51	Pusher Post, Aluminum Non-Relief Relief	ERAA00875A0 ERAA00876A0	65	Adjusting Screw, Aluminum	GE27828X012
			70	Body, Gray cast iron 3/4 NPT 3/4 x 1 NPT 3/4 X 1-1/4 NPT 1 NPT 1 x 1-1/4 NPT 1-1/4 NPT	GE30991X012 GE30992X012 GE17958X012 GE30993X012 GE18079X012 GE18080X012
			71	Bolt, Zinc-plated steel (2 required)	GE32061X012
			72	Pipe Plug, Hex Socket, Steel	1C333528992
			95	Grommet, Nitrile (NBR)	GE35358X012
			96	Slip Disk, Stainless steel	GG05787X012
			100	Lockwire, Stainless steel	T14088T0012

*Recommended spare part.

Industrial Regulators

Emerson Process Management Regulator Technologies, Inc.

USA - Headquarters
McKinney, Texas 75070 USA
Tel: +1 800 558 5853
Outside U.S. +1 972 548 3574

Asia-Pacific
Shanghai 201206, China
Tel: +86 21 2892 9000

Europe
Bologna 40013, Italy
Tel: +39 051 419 0611

Middle East and Africa
Dubai, United Arab Emirates
Tel: +971 4811 8100

Natural Gas Technologies

Emerson Process Management Regulator Technologies, Inc.

USA - Headquarters
McKinney, Texas 75070 USA
Tel: +1 800 558 5853
Outside U.S. +1 972 548 3574

Asia-Pacific
Singapore 128461, Singapore
Tel: +65 6770 8337

Europe
Bologna 40013, Italy
Tel: +39 051 419 0611
Chartres 28008, France
Tel: +33 2 37 33 47 00

TESCOM

Emerson Process Management Tescom Corporation

USA - Headquarters
Elk River, Minnesota 55330-2445, USA
Tels: +1 763 241 3238
+1 800 447 1250

Europe
Selmsdorf 23923, Germany
Tel: +49 38823 31 287

Asia-Pacific
Shanghai 201206, China
Tel: +86 21 2892 9499



The distinctive swirl pattern cast into every actuator casing uniquely identifies the regulator as part of the Fisher® brand Commercial Service Regulator family and assures you of the highest-quality engineering, performance, and support traditionally associated with Fisher, Tartarini™, and Francel™ regulators. Visit www.fishercommercialservice.com to access interactive applications.

For further information visit www.emersonprocess.com/regulators

The Emerson logo is a trademark and service mark of Emerson Electric Co. All other marks are the property of their prospective owners. Fisher is a mark owned by Fisher Controls International LLC, a business of Emerson Process Management.

The contents of this publication are presented for informational purposes only, and while every effort has been made to ensure their accuracy, they are not to be construed as warranties or guarantees, express or implied, regarding the products or services described herein or their use or applicability. We reserve the right to modify or improve the designs or specifications of such products at any time without notice.

Emerson Process Management Regulator Technologies, Inc., does not assume responsibility for the selection, use or maintenance of any product. Responsibility for proper selection, use and maintenance of any Emerson Process Management Regulator Technologies, Inc. product remains solely with the purchaser.