

ES-665 Series Spring-Loaded Thief Hatch

Table of Contents

Introduction.....	1
Specifications	2
Principle of Operation.....	2
Tagging Information.....	2
Installation	2
Maintenance	4
Parts Ordering	5
Parts List.....	5



MODEL ES-665



MODEL ES-665-L

Figure 1. ES-665 and ES-665-L Series Spring-loaded Thief Hatch



WARNING

Failure to follow these instructions or to properly install and maintain this equipment could result in an explosion, fire and/or chemical contamination causing property damage and personal injury or death.

Enardo™ spring-loaded hatch must be installed, operated and maintained in accordance with federal, state and local codes, rules and regulations and Emerson Process Management Regulator Technologies Tulsa, LLC instructions.

Failure to correct trouble could result in a hazardous condition. Call a qualified service person to service the unit. Installation, operation and maintenance procedures performed by unqualified person may result in improper adjustment and unsafe operation. Either condition may result in equipment damage or personal injury. Only a qualified person shall install or service the spring-loaded hatch.

Introduction

Scope of the Manual

This Instruction Manual provides instructions for installation, startup, maintenance and parts ordering information for the ES-665 Series spring-loaded hatch.

ES-665 Series

Specifications

The Specifications table lists the specifications for the ES-665 Series spring-loaded hatch. Specification is stamped on the nameplate attached to the hatches.

Available Constructions

See Product Description

Performance

Tight to 0.10 SCFH at 90% of set pressure, at 68°F / 20°C

Bolt Pattern

Nominal 8 in. Flange API Round

Pressure Setting Range⁽¹⁾

4, 6, 8, 12, 16, 24 and 32 oz./sq. in.

Vacuum Setting Range⁽¹⁾

0.4, 0.9 and 3.5 oz./sq. in.

Temperature Range

-4 to 140°F / -20 to 60°C

Note: Use Fluorosilicone gaskets for lower temperatures to -40°F / -40°C

Construction Material

Casting: Aluminum (non-sparking)

Pressure Gasket: HNBR (standard), Fluorosilicone, Viton® and Ethylene Propylene Diene Monomer (EPDM)

Vacuum Gasket: Fluorosilicone (standard), Viton® and EPDM Food Grade

Optional Equipment

Base Gasket, Bolt Set, Non-Corrosive Coating, Bonding Strap and TopWorx™ Thief Hatch Monitoring

Approximate Shipping Weight

Model ES-665: 25 lbs / 11.3 kg

1. The pressure/temperature limits in this Instruction Manual and any applicable standard or code limitation should not be exceeded.

Product Description

The ES-665 Series is the next evolution in spring-loaded thief hatch design with precision-manufactured internal components, a base and a cover. It is intended for use in applications where ultra-tight sealing is required such as sour crude/gas or where strict environmental emissions standards are enforced.

ES-665 Series Spring-Loaded Hatch Model

Model ES-665 is a spring-loaded thief hatch designed with a round base and cover. It is intended for use on steel and fiberglass storage tanks which require a tighter seal for reduced vapor loss.

Model ES-665-L is a spring-loaded thief hatch designed with a long basin and cover. The long basin serves as a thief shelf. The design also includes an inclining base to keep the basin level. This is a long configuration.

Model ES-665-B is a spring-loaded thief hatch designed with a round base and cover. This hatch is provided with a bleeder attachment making it possible to relieve tank pressure before opening the hatch. This bleeder prevents a spray from discharging when the hatch cover is raised. This is a bleeder vent configuration.

Model ES-665-LB is a spring-loaded thief hatch designed with a long basin and cover with an inclining base and bleeder attachment. This is a long and bleeder vent configuration.

Principle of Operation

Enardo™ gauge hatches are designed to control evaporation losses and protect tanks against excessive pressure or vacuum. When the storage tank pressure is above the setpoint of the hatch, the center assembly opens to relieve excess pressure. When the overpressure has dissipated, the center assembly reseats onto the base to provide tight seal.

Tagging Information

The ES-665 Series hatch is shipped with a tag already attached to the hatch.

For retrofit ES-665 Series center assemblies, the order includes a tag, stainless steel wire and a drive screw. User has the option to attach the tag with wire to the existing hatch lid or to drill a small hole and attach tag with a drive screw on the top of the lid. Examples of tag locations are shown in Figure 2. Location 1 is the hinge pin on the back of the hatch and location 2 is the holes in the ears on the front of the hatch.

Installation



CAUTION

Ensure the tank is at atmospheric pressure before opening. A pressure build-up inside the tank can cause a spray to be emitted from the hatch if opened under pressure.

Viton® is a mark owned E.I. du Pont de Nemours and Co.

Springs are energy storage devices and are dangerous if handled improperly. Always use appropriate safety equipment including safety glasses or shields anytime you are working with a spring-loaded hatch.

WARNING

Ensure hardware and tools used during installation do not interfere with or exert upward forces on the hatch base.

Complete ES-665 Series Hatch

WARNING

The ES-665 Series Hatch is not necessarily grounded when installed on fiberglass reinforced plastic tanks unless the base is electrically bonded to the tank.

To avoid personal injury or property damage resulting from the effects of a static electricity discharge from hatch components in a hazardous atmosphere or where the process fluid is combustible, electrically bond the base to the tank with grounding strap.

1. Install the spring-loaded thief hatch on a mating API flange bolting circle of 16 bolt holes on a 10 - 3/8 in. circle for a normal 8 in. opening.
2. For installation of the hatch directly to the tank roof, place the base gasket on the bottom of the hatch flange and place on the tank roof with holes lined up. The slope on the roof should not exceed 5 degrees. Insert the 16 bolts from the bottom up by reaching inside the tank, through the hatch and opening in the tank roof. Attach each nut to the bolt from the outside. Tighten all nuts in a circular manner and make sure the hatch is fastened securely. The bolt size is 5/8 in. The minimum starting torque should be 20 ft-lbs and the maximum torque is 45 ft-lbs.
3. For installation of the hatch to a flanged pipe with an 8 in. API flange pattern, simply place the base gasket on the flanged pipe, line up bolt holes and place hatch on top of base gasket. Install nuts and bolts and tighten in a circular manner. Ensure hatch is fastened securely.

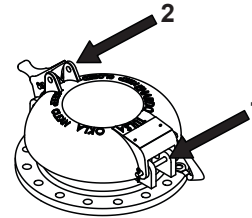
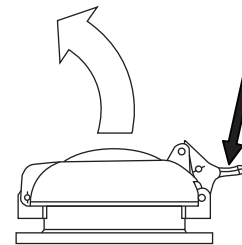

Figure 2. Example Tag Wire Locations

Retrofit ES-665 Series Center Hatch

The ES-665 Series center assembly can also be installed as a retrofit into an existing 660 or ES-660 Series hatch by following six simple steps.



1. Open existing 660 or ES-660 Series hatch by pushing down on lid and opening latch.

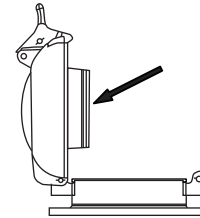

2. Remove the existing center assembly by pressing the center assembly inward against the spring pressure and turning one quarter rotation to the right or left.

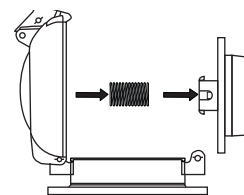

3. Remove existing center assembly and associated pressure spring.

ES-665 Series

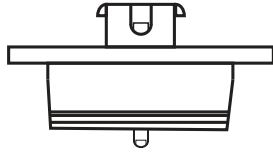

4. New ES-665 Series center assembly can be identified by a green anodized vacuum pallet.

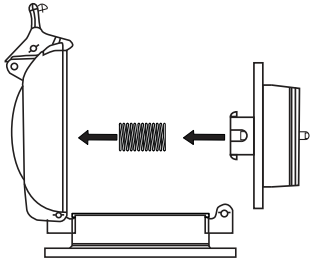

5. Install existing or new pressure spring and ES-665 Series center assembly. Place the pressure spring into the center assembly, then press this combination into the lid. Once the center assembly is pressed fully into lid, turn center assembly one quarter rotation to the right or left, then slowly allow spring to push the center assembly back out until center assembly is secured in the grooves in the lid. If center assembly comes back out fully, follow instructions in this step again until the center assembly is properly secured in the lid.

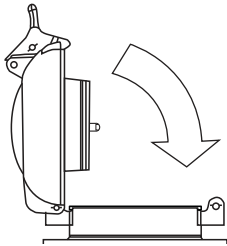

6. Close the hatch by pressing down on the lid and latching the hatch.
7. Permanently mark through the older model number on the nameplate to ES-665 Series.

Maintenance

Perform a scheduled maintenance every three (3) months and more frequently in corrosive or dusty atmospheres. To perform normal maintenance, inspect the pressure gaskets and vacuum gaskets.

COUNTERSINK
SIDE UP FOR
O-RING

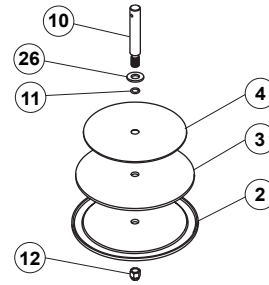

Figure 3. ES-665 Series Vacuum Assembly

To ensure efficient operation of all hatches, use a clean, nonabrasive, lint-free cloth or paper towel to carefully wipe off the pressure and vacuum seats and gaskets every time the hatch is opened. This prevents accumulation of residue that can deteriorate the performance of the valves.

Under average operating conditions, replace the pressure and vacuum gaskets once a year. Replace the base gasket only when a leak is noticed at the bolting area or if the hatch is removed, breaking the seal. If the hatch is continually relieving, the user should be alerted that there is a problem and a close inspection should be made to determine the cause.

To easily identify the parts, see Figure 5 for an exploded view of ES-665 Series.

Note

For parts information refer to the catalog data sheet on each model.

Gasket and Spring Replacement

Vacuum Assembly

1. The vacuum gasket is located between the vacuum pallet and the seal support on the vacuum assembly. The vacuum assembly seals against the underside of the center assembly. To remove the center assembly, depress the center assembly inward and turn one quarter rotation to the right or left (See installation of *Retrofit ES-665 Series Center Hatch, step 2*). Once the center assembly is removed, remove the cotter pin and the conical shaped vacuum spring from the vacuum stem.
2. Pull the vacuum assembly out from the bottom side of the center assembly. Remove and replace the vacuum gasket (See Table 2 for vacuum gasket options) from between the vacuum pallet and the seal support.

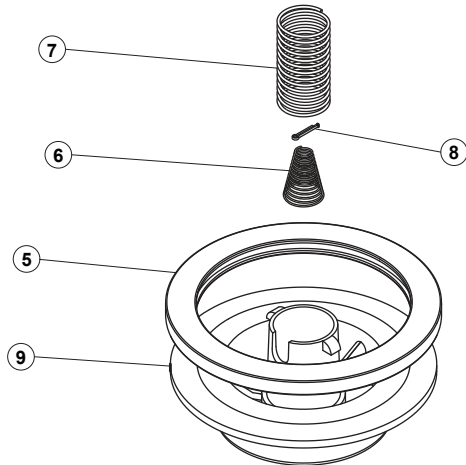

Figure 4. ES-665 Series Center and Pressure Gasket

3. Reassemble the vacuum assembly, spring and cotter key in the reverse order of removal. Replace center assembly into lid (See installation of *Retrofit ES-665 Series Center Hatch, step 5*).

Pressure Assembly

1. To remove the center assembly, depress the assembly inward and turn one quarter rotation to the right or left (See installation of *Retrofit ES-665 Series Center Hatch, step 2*).
2. The pressure gasket or pressure spring can simply be removed and replaced. The pressure gasket (See Table 1 for pressure gasket options) is enveloped around the edge of the center assembly.
3. Stretch the old gasket off and fit the new one around the circular lip. Ensure that the envelope pressure gasket is installed squarely and flat around the circumference of the center.
4. When the center is assembled, replace the center assembly into the lid (See installation of *Retrofit ES-665 Series Center Hatch, step 5*). Under average operating conditions, springs should be replaced every two (2) years.

Parts List (Figure 5)

Models ES-665, ES-665-L, ES-665-B and ES-665-LB

Key	Description	Part Number
1	Base, Hatch	ERAA32198A0
2	Disk, Pallet	NE8559029A0
3	Gasket, Vacuum	See Table 2
4	Seal Support	NE8554636A0
5	Gasket, Envelope Pressure	See Table 1
6	Spring, Vacuum	See Table 4
7	Spring, Pressure	See Table 3
8	Pin, Cotter, 1 in.	NE2022101A0
9	Center	ERAA32389A0
10	Stem	NE8568824A0
11	O-ring	NE2012710A0
12	Nut, 3/8 – 16 in. Hex Nylock	NE2059201A0
13	Lid	NE4522100A0
14	Latch	ERAA32444A0
15	Pin, Latch	
	Model ES-665 (1 required)	NE4505103A0
	Model ES-665-L (1 required)	NE4505103A0
	Model ES-665-B (3 required)	NE4505103A0
	Model ES-664-LB (3 required)	NE4505103A0
16	Clip, Hinge Pin	
	Model ES-665 (2 required)	NE2027100A0
	Model ES-665-L (6 required)	NE2027100A0
	Model ES-665-B (6 required)	NE2027100A0
	Model ES-664-LB (10 required)	NE2027100A0
17	Pin, Latching	NE4505118A0
19	Pin, Hatch Hinge	NE4505113A0
20	Bushing (2 required)	NE8600403A0
21	Spring, Hinge (2 required)	NE4504006A0
22	Nut, 1/4 in. (Optional)	NE2013322A0
23	Bonding Strap (Optional)	NE2050006A0
24	Washer, Lock 1/4 in. (Optional)	NE2012560A0
24	Screw, 1/4 in. (Optional)	NE2021817A0
26	Washer, Flat, 5/16 in.	NE2012584A0
27	Nameplate	NE4501209A0
28	Washer, Thrust Bearing (2 required)	NE2020608A0
29	Thrust Bearing	NE2020609A0
31	Bleeder, Hatch	NE4540200A0
32	Handle, Hatch Bleeder	NE4524400A0
33	Roller, Bleeder	NE4505200A0

Parts Ordering

When corresponding with your local Sales Office about this equipment, always reference the equipment model number that can be found on the name plate.

ES-665 Series

Table 1. Pressure (Envelope) Gasket Options

MATERIAL	PART NUMBER
HNBR (standard)	NE4504601A0
Blue Fluorocarbon (FKM)	NE4504603A0
Fluorosilicone	NE4504605A0
EPDM	NE4504604A0

Table 2. Vacuum Gasket Options

MATERIAL	PART NUMBER
Fluorosilicone	NE4504705A0
Blue Fluorocarbon (FKM) (standard)	NE4504708A0
EPDM Food Grade	NE4504711A0

Table 3. Pressure Spring Options

SETTING, OZ./SQ. IN.	MATERIAL	COLOR 1	COLOR 2	PART NUMBER
4	H.D. Steel (Galvanized)	Dark Green	Dark Green	NE4502300A0
6	H.D. Steel (Galvanized)	Brown	Brown	NE4502500A0
8	H.D. Steel (Galvanized)	Orange	Orange	NE4502700A0
12	H.D. Steel (Galvanized)	Pink	Pink	NE4502900A0
16	H.D. Steel (Galvanized)	Dark Blue	Dark Blue	NE4503100A0
24	Drawn Carbon steel Wire (Galvanized)	Red	Red	NE4503300A0
32	H.D. Steel (Galvanized)	Purple	Purple	NE4503201A0
4	Inconel®	Dark Green	White	NE4502400A0
6	Inconel®	Brown	White	NE4502600A0
8	Inconel®	Orange	White	NE4502800A0
12	Inconel®	Pink	White	NE4503000A0
16	Inconel®	Dark Blue	White	NE4503200A0
24	Inconel®	Red	White	NE4503400A0
32	Inconel®	Purple	White	NE4503600A0

Table 4. Vacuum Spring Options

SETTING, OZ./SQ. IN.	MATERIAL	COLOR 1	COLOR 2	PART NUMBER
0.4	H.D. Steel (Galvanized)	Light Blue	Light Blue	NE4503700A0
0.9	Music Wire	Gray	Gray	NE4504100A0
3.5	H.D. Steel (Galvanized)	Yellow	Yellow	NE4503900A0
0.4	Inconel®	Light Blue	White	NE4503800A0
0.9	Inconel®	Gray	White	NE4504200A0

Inconel® is a mark owned by Special Metals Corporation.

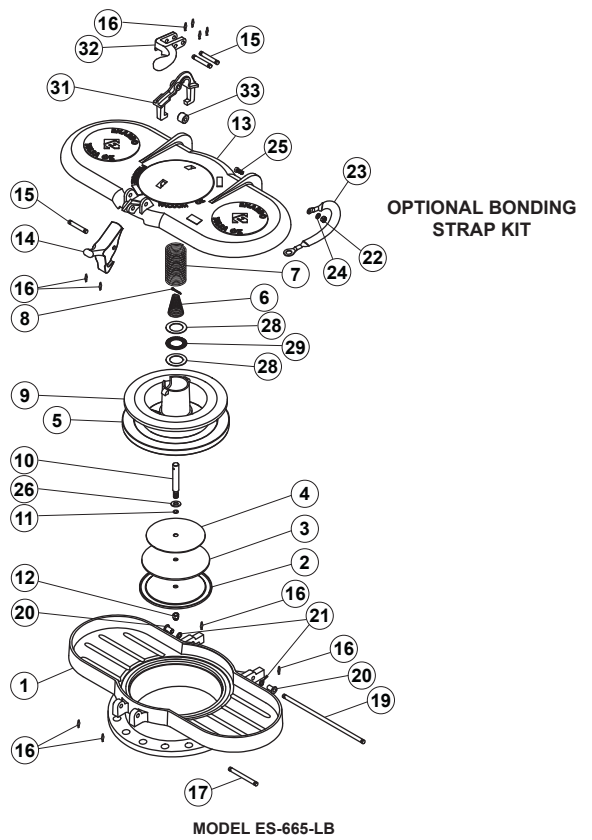
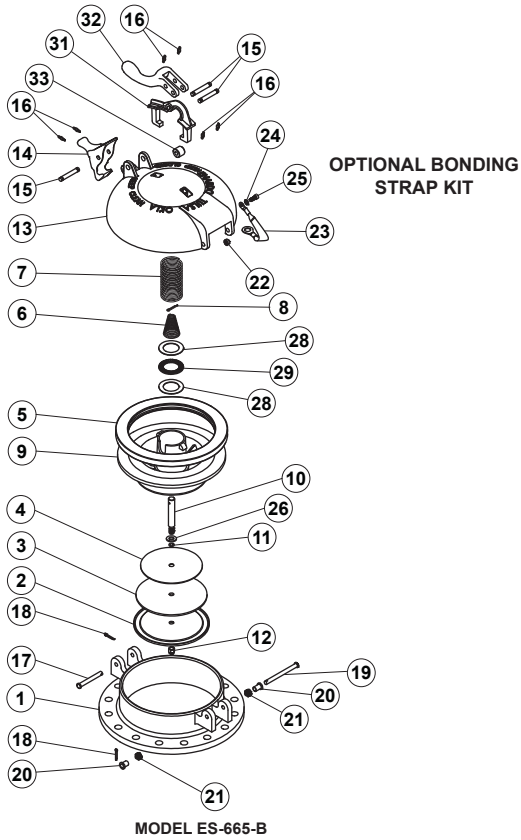
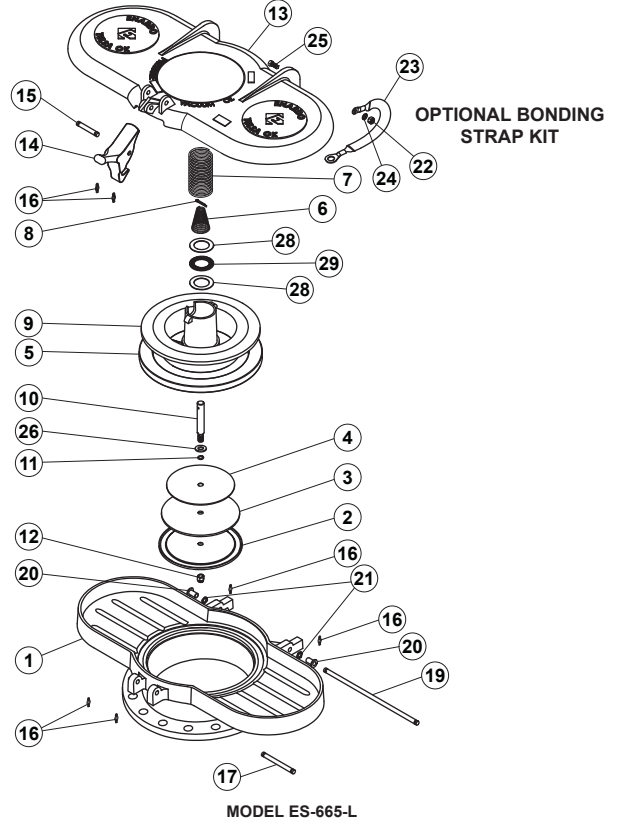
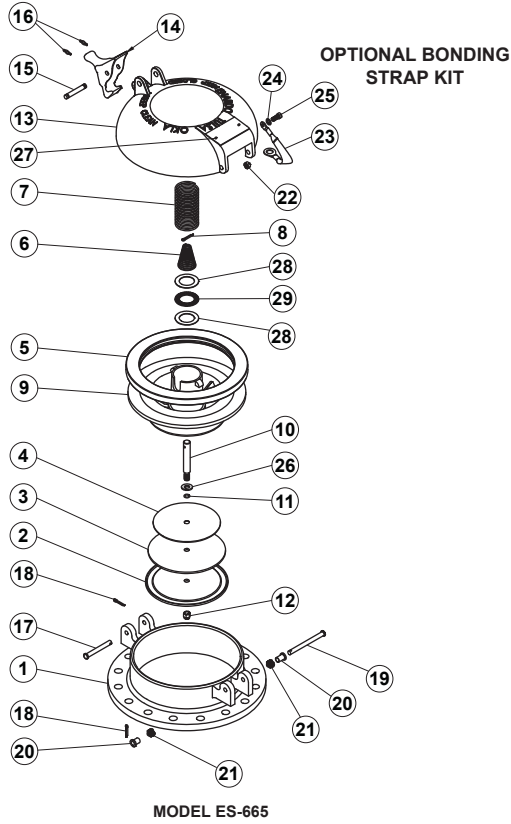

NOTE: THIEF HANGER IDENTIFIES LATCH SIDE OF BASE

Figure 5. ES-665, ES-665-L, ES-665-B and ES-665-LB Exploded View

ES-665 Series

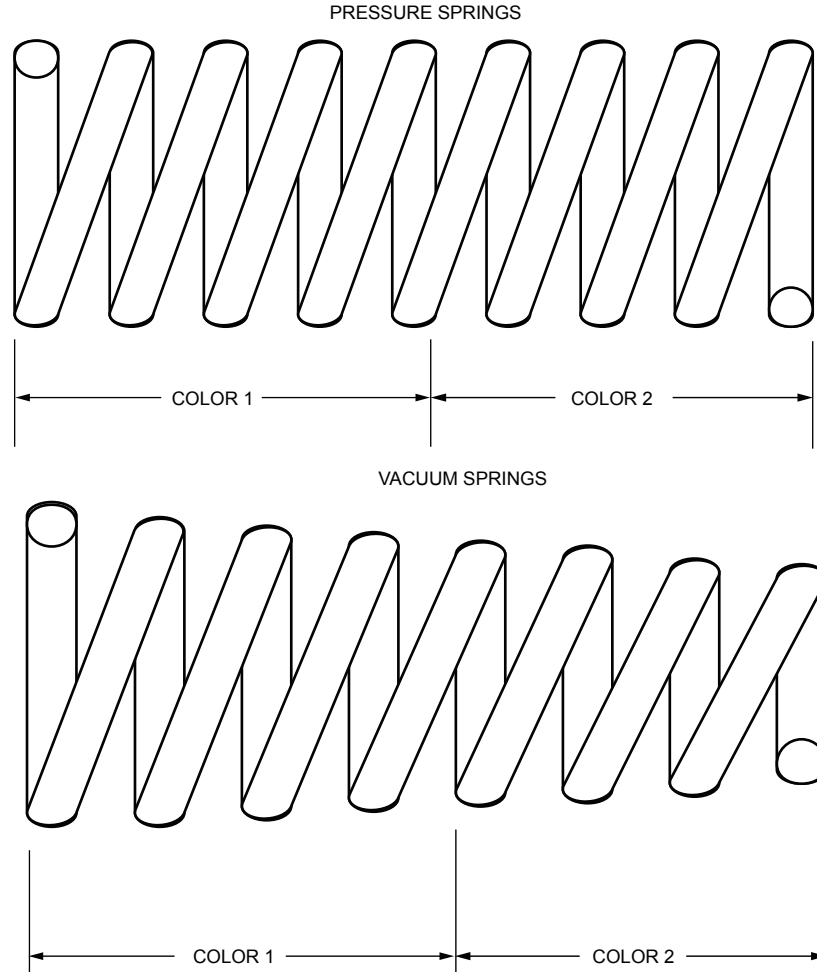

Figure 6. ES-665 Series Spring Identification

North America Only

✉ Webadmin.Regulators@emerson.com

Facebook.com/EmersonAutomationSolutions

🔍 Enardo.com

LinkedIn.com/company/emerson-automation-solutions

Twitter.com/emr_automation

Emerson Automation Solutions

Americas

McKinney, Texas 75070 USA

T +1 800 558 5853

+1 972 548 3574

Tulsa, OK 74146 USA

T +1 918 662 6161

Europe

Bologna 40013, Italy

T +39 051 419 0611

Asia Pacific

Singapore 128461, Singapore

T +65 6777 8211

Middle East and Africa

Dubai, United Arab Emirates

T +971 4 811 8100

D104126X012 © 2017, 2023 Emerson Process Management Regulator Technologies, Inc. All rights reserved. 06/23.

The Emerson logo is a trademark and service mark of Emerson Electric Co. All other marks are the property of their prospective owners. Enardo™ is a mark owned by Regulator Technologies Tulsa, LLC, a business of Emerson Automation Solutions.

The contents of this publication are presented for informational purposes only, and while every effort has been made to ensure their accuracy, they are not to be construed as warranties or guarantees, express or implied, regarding the products or services described herein or their use or applicability. We reserve the right to modify or improve the designs or specifications of such products at any time without notice.

Emerson Process Management Regulator Technologies Tulsa, LLC does not assume responsibility for the selection, use or maintenance of any product. Responsibility for proper selection, use and maintenance of any Emerson Process Management Regulator Technologies Tulsa, LLC product remains solely with the purchaser.

