

March 2015

Types H282, H722, H732A, H822, H832A, H832AL, H882, H5112 and H8112 Large Internal Relief Valves

WARNING

Failure to follow these instructions or to properly install and maintain this equipment could result in an explosion, fire and/or chemical contamination causing property damage and personal injury or death.

A person should NEVER stand directly over or in front of or look directly into a relief valve when the tank is pressurized. The relief valve could suddenly “pop” open blowing gas, dirt and other debris into the person’s face and eyes.

Fisher® equipment must be installed, operated and maintained in accordance with federal, state and local codes, rules and regulations and the manufacturer’s instructions. For LP-Gas service, an approved relief valve (such as one listed by UL®) should be used or approved by the authority having jurisdiction. In addition, in most states the installation must also comply with NFPA No. 58, US Department of Transportation (DOT) and/or ANSI K61.1 standards.

Only personnel trained in the proper procedures, codes, standards and regulations of the LP-Gas, Anhydrous Ammonia (NH₃) or other applicable industry should install and inspect this equipment.



Figure 1. Type H Large Internal Relief Valves

UL® is a mark owned by Underwriters Laboratories.



www.fisherregulators.com



H Series

Specifications

The Specifications section on this page provides the ratings and other specifications for the Types H282, H722, H732A, H822, H832A, H832AL, H882, H5112 and H8112 relief valves. Factory specifications are engraved on the body of the relief valve at the factory.

Body Size, Tank Connection

Types H282, H722, H882, H5112 and H8112:
2 NPT

Types H732A and H832A: 3 NPT

Discharge Stack Outlet Connection

Available only on Types H282, H882, H5112 and H8112: 3 NPT

Types H282, H882, H5112 and H8112 Pipe-Away

Adapter: Type P104-24 pipe-away adapter

Maximum Inlet Pressure (Body Rating)⁽¹⁾

480 psig / 33.0 bar

Rain Cap and Installation Tool

Types H722 and H822: Type P297 Rain Cap
Type P304 (1-1/2 in. / 38 mm Hex bar) Wrench

Types H732A and H832A: Type P298 Rain Cap
Type P305 (2-1/2 in. / 64 mm Hex bar) Wrench

Types H282, H882, H5112 and H8112:
Type P299 Rain Cap

Temperature Capabilities⁽¹⁾

Types H282, H5112, H722, H732A, H882, H8112, H822 and H832A: -20 to 160°F / -29 to 71°C

Type H832AL: -60 to 150°F / -51 to 66°C

Start-to-discharge Pressure and Spring(s) Range(s)

100 to 400 psig / 6.9 to 27.5 bar

Construction Materials

Body:

Types H282 and H882: Brass

Types H5112 and H8112: Stainless steel

Types H722, H732A, H822 and H832A:
Stainless steel

Stem: Stainless steel

Disc Holder: Stainless steel

Disc:

Types H282, H722, H732A and H5112: Nitrile (NBR)

Types H822, H832A, H882 and H8112:

Nitrile (NBR) (**standard**)

Contact factory for other disc materials

that are available: Fluorocarbon (FKM), Ethylenepropolyene (EPR), Neoprene (CR), Perfluoroelastomer (FFKM) and Low-Temperature Nitrile (NBR)

Springs: Stainless steel

Approximate Unit Weights

Types H282 and H882: 10 lbs / 5 kg

Types H5112 and H8112: 10 lbs / 5 kg

Types H722 and H822: 2.75 lbs / 1 kg

Types H732A and H832A: 7.5 lbs / 3 kg

1. The pressure/temperature limits in this Instruction Manual and any applicable standard or code limitation should not be exceeded.

Introduction

Scope of the Manual

This manual covers instructions for Types H282, H722, H732A, H822, H832A, H882, H5112 and H8112 relief valves **which shall be used only in vapor applications**. The valves are typically installed in ASME tanks and Department of Transportation (DOT) cargo tanks (see Figures 3, 4 and 5). Types H282, H882, H5112 and H8112 relief valves are for installation or use in stationary tank applications only.

Product Description

Type H282: Used on stationary LP-Gas bulk storage tanks. Not for use in transport or mobile tank applications or Anhydrous Ammonia (NH₃) service. Standard UL[®] and ASME setpoints are available.

Type H5112: Used on stationary LP-Gas or Anhydrous Ammonia (NH₃) Bulk Storage tanks. Not for use in transport or mobile tank applications. Standard UL[®] and ASME setpoints are available.

Types H722 and H732A: Used on LP-Gas or Anhydrous Ammonia (NH₃) Cargo tanks. Standard UL[®] and ASME setpoints are available.

Types H882 and H8112: Used for a variety of compressed gases in bulk stationary storage. Contact the factory regarding selection of compatible sealing materials. Not for use in transport or mobile tank applications. ASME setpoints and flow capacities are available and all units are provided with serial numbers.

Types H822 and H832A: Used for a variety of compressed gases in mobile and stationary storage. Contact the factory regarding selection of compatible sealing materials. ASME setpoints and flow capacities are available and all units are provided with serial numbers.

UL[®] is a mark owned by Underwriters Laboratories.

Things To Tell The Gas Customer

1. The purpose of a relief valve is to keep the tank from rupturing from excessive tank pressure by venting gas to the atmosphere until the tank pressure drops. The following can cause excessive tank pressure:
 - a. Exposure to fire or radiant heat including hot summer days
 - b. New or refilled tanks not fully purged of air
 - c. Tank colors (other than white) increase the heat absorption of the tank raising the pressure in the tank
 - d. Propane or other service products with “vapor pressures” out of specification, i.e., “Hot Gas”
 - e. Overfilling the tank
2. Do not beat, pound or hit the relief valve with hammers or other tools or attempt to force the valve closed as this will not stop gas discharge and could damage relief valve parts or rupture the tank.
3. Call your gas dealer immediately if the relief valve discharges gas. The relief valve and complete system should be inspected to determine the cause of the relief valve discharge and any necessary maintenance should be completed.

Specifications



WARNING

If the valve is to be for service other than LP-Gas or Anhydrous Ammonia (NH₃), contact your local Sales Office to determine if the valve materials are suitable for the particular service. Types H282 and H882 relief valves contain brass and must not be used on Anhydrous Ammonia (NH₃) service. Failure to do so could result in personal injury, property damage, explosion, fire or chemical contamination.

Types H282, H882, H5112 and H8112 must not be used in mobile tank or transport service. Installation in these applications may result in personal injury, property damage, explosion, fire or chemical contamination.

The Specifications section lists specifications for these relief valves.

Set pressures and flow capacity requirements vary by product service. Actual flow capacities vary by relief valve size and setpoint. For special service applications other disc material and setpoints are available from the factory. Consult the factory or your Fisher® Catalog for size, set pressure and flow capacity combinations.

Setpoint is denoted by the suffix numbers following the dash (-). Disc material is denoted by a letter following the type number: Type H882V-250 has a Fluorocarbon (FKM) disc and setpoint of 250 psi / 17.2 bar.

Nitrile (NBR)	No letter
Fluorocarbon (FKM)	V
Ethylenepropylene (EPR)	E
Neoprene (CR)	N
Perfluoroelastomer (FFKM)	K
Low-Temperature Nitrile (NBR)	L

For Liquefied Petroleum Gas service, UL® listed valves are required by most states, although some states require ASME capacity rated valves. Be sure the valve is rated and stamped to meet the requirements of the state where it will be used. The valve should also have sufficient capacity for the container size in which it is used. Required relief valve capacity is a function of the container surface area. For Liquefied Petroleum Gas applications consult NFPA #58. For other product applications consult appropriate product standards.

The start-to-discharge pressure stamped on the valve must be correct for the design pressure of the container.

Do not use a valve with a start-to-discharge pressure higher than that allowed by the design pressure of the container.

If a relief valve is installed in a tank with an inlet dip tube, be sure that the dip tube does not restrict the inlet flow area as this may restrict the relief valve flow capacity to less than the stamped capacity on the valve. If a Type H282, H882, H5112 or H8112 relief valve has an outlet pipe-away stack, a restriction may result that reduces valve capacity below that stamped on the valve. In these cases, the total system capacity must be sufficient to meet the sizing requirements for the container being used.

H Series

Principle of Operation

The relief valve (refer to Figure 2) is held closed by the spring force seating the seal against the orifice.

When the tank pressure exceeds the spring force, the valve seal lifts off the orifice allowing gas to discharge through the valve to the air.

Gas discharge initially may be small producing only seepage and a light “hissing” sound. As pressure increases and gas volume discharge continues, a “popping” condition occurs with large volumes of gas discharging and a loud “hissing or roaring” sound.

When the tank pressure decreases enough, the spring force closes the valve seal back against the orifice stopping further discharge.

Installation

WARNING

Install these relief valves only in the container vapor space to provide relief capacity for the tank. Failure to do so could result in improper relief capacity that could cause the tank to rupture in the event of an emergency condition. A ruptured tank may cause property damage and personal injury or death.

All containers must be purged to remove air from the container. Failure to properly purge may result in excessive pressure and the possibility of “popping” the relief valve when the container is filled. Follow recognized procedures for purging air from storage tanks. A good reference is NPGA #133, PURGING LP-GAS CONTAINERS.

Relief valves must have direct contact with the vapor space of the containers. Install the valve so that flow is unobstructed on both the inlet and outlet of the relief valve. Be certain that any discharge from the valve will not impinge on the container, adjacent containers or any source of ignition.

Coat the male threads of the valve with UL® listed sealing compound. Do not use PTFE tape. Do not allow excess compound to drip into the container or flow around the bottom edge of the pipe threads. Screw the valve into the coupling hand tight and then wrench tighten it for approximately two additional turns. Do not install the valve with such extreme torque that the coupling cuts additional threads into

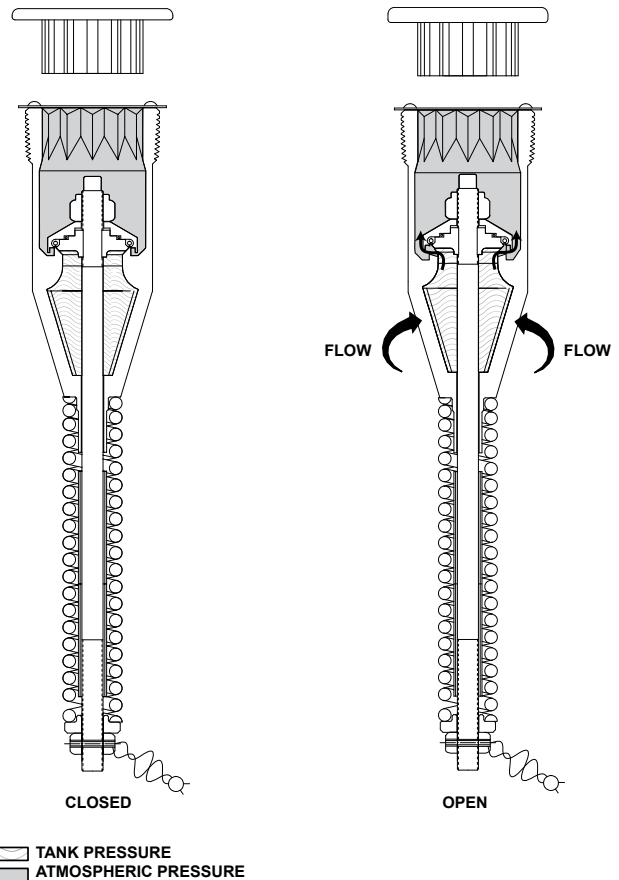

Figure 2. Operational Schematic

the valve. This could cause valve distortion and affect the internal working parts. Larger size valves may require an additional amount of torque to obtain a leak-free connection. The Types H722, H732A, H822 and H832A will require an installation tool. See Specifications section.

Raincaps are required on all valves. The raincap should be kept in place to keep moisture and dirt out of the relief valve discharge area. An out-of-place raincap indicates the valve may have opened to relieve overpressure. Type H282, H882, H5112 or H8112 relief valves have a drain hole in the body, which must remain open at all times. It is located under the deflector on the side of the relief valve body. Types H722, H732A, H822 and H832A relief valves on cargo tank applications do not have drain holes and must be protected as specified by DOT, NFPA #58 and other applicable laws, codes and standards. **Do not pack the outlet side of the Types H722, H732A, H822 and H832A relief valves with grease or other material to keep out dirt and moisture.**

 **CAUTION**

Greases and other materials placed in relief valve outlet chambers may harden and prevent the opening of the relief valve or attack the elastomer disc materials causing premature leakage or possibly tank rupture.

Each application will dictate whether discharge stacks or deflectors are required. These are separate devices mounted to the outlet of the valve to control discharge direction. The Types H282, H882, H5112 and H8112 are equipped with deflectors as standard. They also have a 3 NPT thread on the outlet so that a coupling and discharge stack can be added as needed. Consult the applicable standard to determine if these additional devices are required. Types H722, H732A, H822 and H832A relief valves cannot be equipped with deflectors or discharge stacks.

Maintenance, Repair and/or Replacement

 **WARNING**

Any valve that has fully opened (popped) should be tested to see if it is within the allowable start-to-discharge pressure setting. If it is not within the correct range, it must be replaced. Relief valve start-to-discharge and reseal pressures may be lower if the valve has fully opened (popped).

Some relief valve installations require periodic testing or replacement, such as those required by DOT, NFPA #58, NFPA Pamphlet 59 (LP-Gas Utility Gas Plants) and ANSI K61.1. It is recommended that all relief valves be regularly inspected for visible damage, dirt, corrosion, missing raincaps, paint inside outlet, tampering, etc. If any of the preceding is evident or questionable, the valve should be retested and repaired if necessary or replaced immediately.

Emerson Process Management Regulator Technologies, Inc. recommends that a relief valve not be used for longer than 12 years from the date of manufacture. Any repair or resetting of the relief valve

does not extend the service life past the 12 years from the original date of manufacture. The service application of the relief valve and the environment in which it operates may shorten the safe service life of the relief valve. Replacement of the relief valve in less than 12 years may be required.

The discharge side of the relief valve body must be kept free of dirt, water and other foreign matter which can damage the valve seals or block the valves closed and can prevent the valve from opening. Remove the blockage and retest the valves or replace as necessary.

Relief valves are precisely set and wire sealed by the manufacturer for the correct start-to-discharge setting. Repair and resetting the relief valve should never be attempted except by a repair facility that has a National Board VR stamp or has been approved to repair and reset relief valves by the appropriate governmental authority.

Seals in the relief valve are subject to normal deterioration and should be tested or inspected as part of regular inspection and maintenance of the relief valve. The seals may require replacement prior to the end of the relief valve service life due to severe service conditions, gas vapor impurities or code requirements.

Relief Valve Testing

The following procedure describes how to determine the setpoint and reseal of a relief valve.

- If the setpoint or reseal does not comply with the requirements after removal from service, then resetting or complete replacement of the relief valve is required.
- If resetting the relief valve is required, send it to a repair facility that has a National Board VR stamp or has been approved to repair and reset relief valves by the appropriate governmental authority.

 **WARNING**

A person should NEVER stand directly over or in front of or look directly into a relief valve when the tank or test fixture is pressurized. The relief valve could suddenly “pop” open blowing gas, dirt and other debris into the person’s face and eyes.

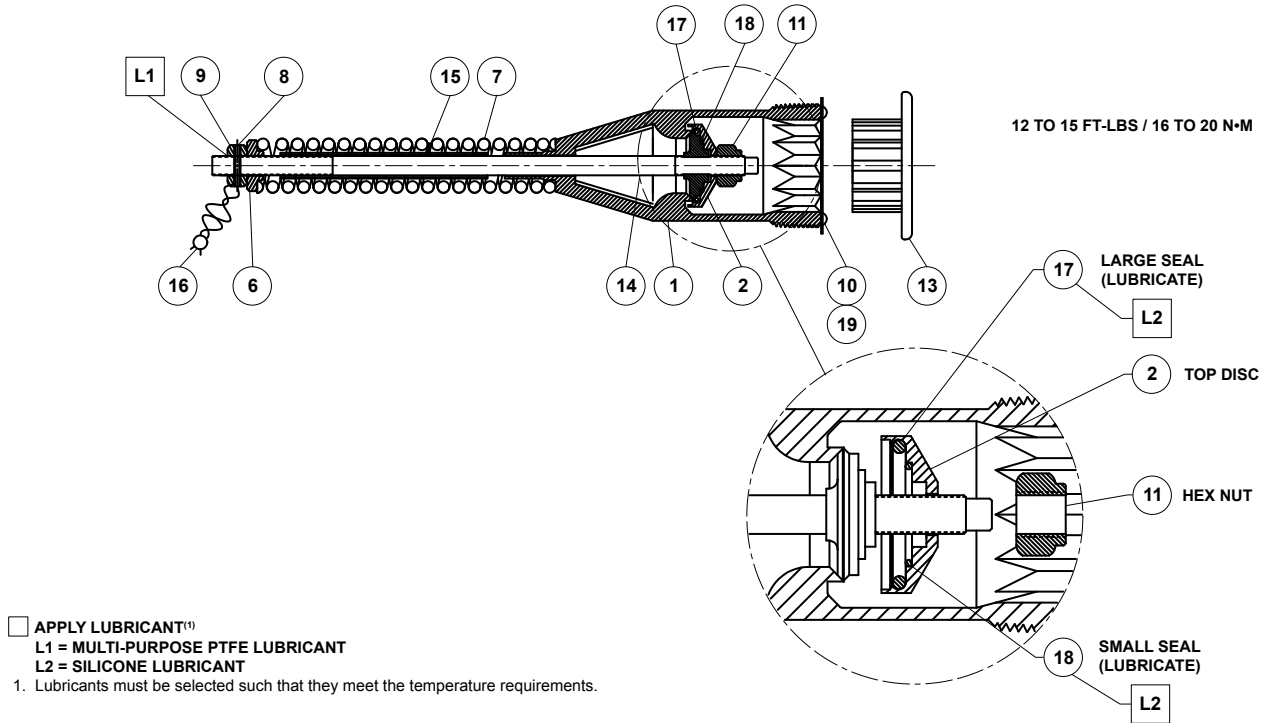

Figure 3. Types H722 and H822 Relief Valves

1. Install relief valve in the tester. Fill the relief valve body outlet with water. A calibrated pressure gauge should be used to indicate relief valve inlet pressure readings. The gauge should be at least 6 in. / 152 mm in diameter with 2 psi / 0.14 bar increments and the anticipated start-to-discharge should be readable in the middle third of the gauge range.
2. Slowly apply air pressure at the rate of 2 psi / 0.14 bar per second to the relief valve inlet until start-to-discharge. Start-to-discharge pressure is the point at which the first bubbles appear in a water seal not to exceed 4 in. / 102 mm. Do not increase pressure above the start to discharge pressure.
3. Repeat the start-to-discharge tests at least 3 times to ensure setpoint accuracy. Setpoint readings should be within 1 to 2 psi / 0.07 to 0.14 bar of each other for consistency.
4. Start-to-discharge pressure should be within 0 to 10% higher than the stamped set pressure on valve. Example-stamped pressure is 250 psi / 17.2 bar. Start-to-discharge minimum pressure: 250 psi / 17.2 bar and start-to-discharge pressure maximum: 275 psi / 19.0 bar.

5. Verify reseal pressure. After reaching the start-to-discharge setting, reduce pressure to 90% of the observed set pressure. There should be no bubbles visible through the water seal at that pressure.

WARNING

These relief valves must be removed from service before attempting to check setpoint, replace seals or repair. Failure to do so could result in the discharge of high-pressure gas and possible personal injury.

CAUTION

Only a qualified repair facility should test and replace the relief valve seals. Only a qualified repair facility with a National Board VR stamp or authorized by a governmental agency should repair or reset relief valves.

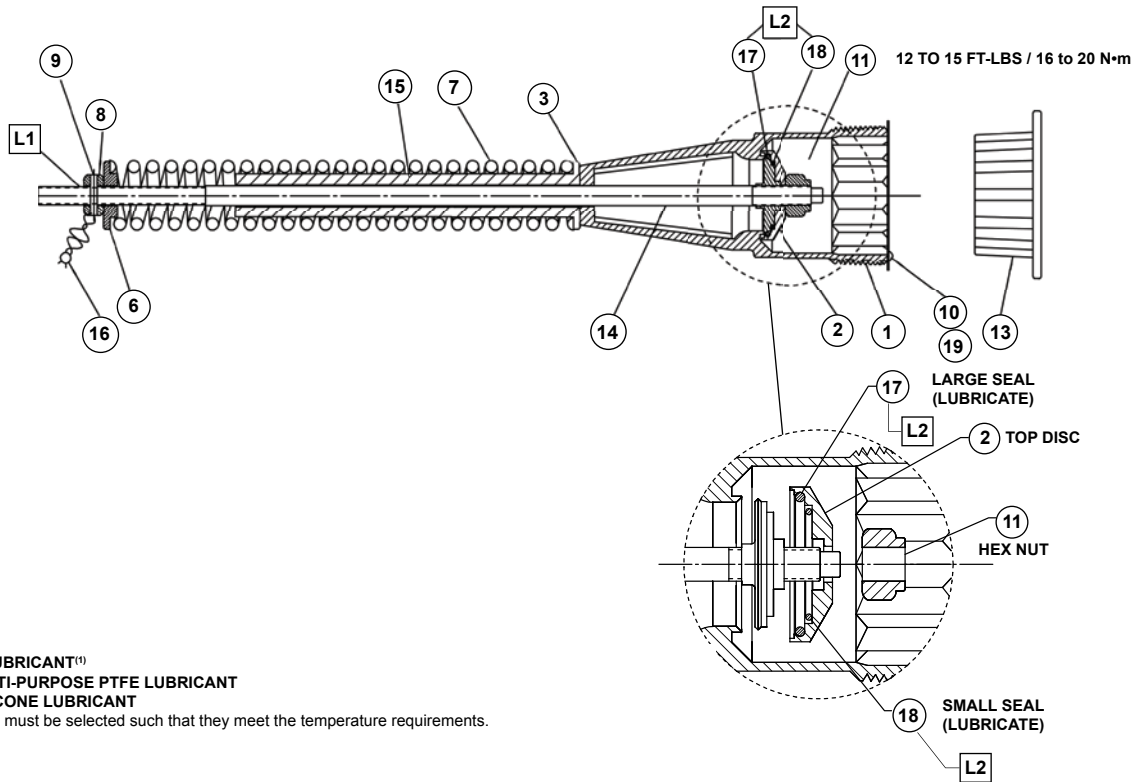

Figure 4. Types H732A and H832A Relief Valves

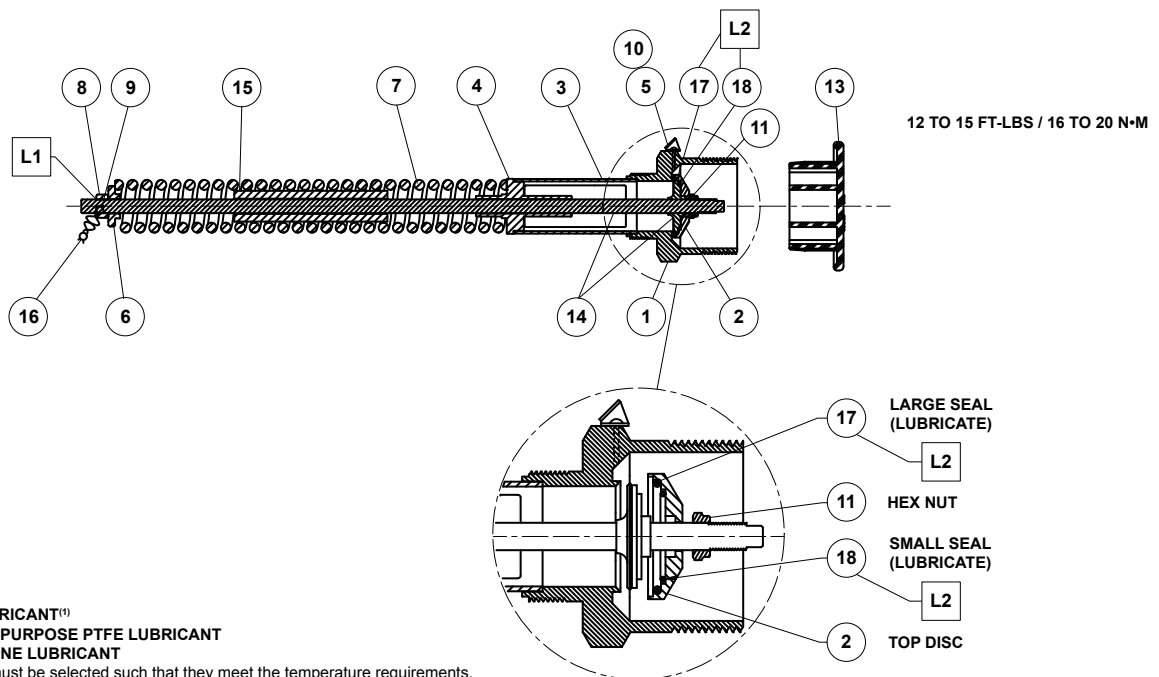

Figure 5. Types H282, H882, H5112 and H8112 Relief Valves

H Series

Parts List (Refer to Figures 3, 4 and 5)

Key	Description	Key	Description
1	Body	11	Hex Locknut
2	Top Disc	13	Rain Cap
3	Yoke (Types H282, H882, H5112 and H8112 only)	14	Stem/Bottom Disc Assembly
4	Guide Bushing (Types H282, H882, H5112 and H8112 only)	15	Spring tube/Stem Guide
5	Pipe-away Deflector (Types H282, H882, H5112 and H8112 only)	16	Lead Seal and Wire
6	Spring Seat	17	Large seal
7	Spring	18	Small seal
8	Hex Adjusting Nut	19	Nameplates (Types H722, H732A, H822 and H832A)
9	Roll Pin		
10	Drive Screw Types H282, H882, H5112 and H8112 (2 required) Types H722, H732A, H822 and H832A (4 required)		

LP-Gas Equipment

Emerson Process Management Regulator Technologies, Inc.

USA - Headquarters
McKinney, Texas 75070 USA
Tel: +1 800 558 5853
Outside U.S. +1 972 548 3574

For further information visit www.fisherregulators.com

The Emerson logo is a trademark and service mark of Emerson Electric Co. All other marks are the property of their prospective owners. Fisher is a mark owned by Fisher Controls International LLC, a business of Emerson Process Management.

The contents of this publication are presented for informational purposes only, and while every effort has been made to ensure their accuracy, they are not to be construed as warranties or guarantees, express or implied, regarding the products or services described herein or their use or applicability. We reserve the right to modify or improve the designs or specifications of such products at any time without notice.

Emerson Process Management Regulator Technologies, Inc. does not assume responsibility for the selection, use or maintenance of any product. Responsibility for proper selection, use and maintenance of any Emerson Process Management Regulator Technologies, Inc. product remains solely with the purchaser.