

March 2009

Type N201 Automatic Cylinder Filling Valve



WARNING

Install, use, and maintain this equipment according to manufacturer's instructions and all federal, state, local laws and codes, and NFPA Pamphlet 58. Periodic inspection and maintenance is essential.

Introduction

Type N201 automatic cylinder filling valve is supplied completely piped up, and consists of a filler valve assembly, two Type 67 regulators with pressure gauges, a trip valve, and special parts for alternate scale installations.

Principle of Operation

Refer to Figure 2. Supply pressure registers at regulators 1 and 2. Pressure from regulator 1 registers beneath the lower diaphragm of the filler valve, see "A" in Figure 2. This pressure holds the lower valve closed, preventing pressure from regulator 2 from registering on the upper diaphragm. Spring force holds the upper valve open, and liquid from the charging pump can enter the cylinder to be filled.

When the cylinder reaches the predetermined weight set on the scale, the beam button on the scale beam contacts the trip valve, see "B" in Figure 2. The trip valve opens to exhaust pressure from under the lower diaphragm. Spring force opens the lower valve, allowing pressure from regulator 2 to register on the upper diaphragm. This closes the upper valve, and stops flow through the orifice. A red button indicates that the filler valve is closed and that the cylinder is full. Removing the full cylinder from the scale closes the trip valve and permits the system to reset itself for the next cylinder.



P1090

Figure 1. Type N201 Automatic Cylinder Filling Valve

Installation

Refer to Figure 3.

1. Connect the top 1/2 FNPT connection "C" of the filler valve to the charging manifold.
2. Determine if the trip valve hose is long enough to reach the scale frame as shown. If not, insert 1/8-inch (3,2 mm) pipe as needed.
3. Standard trip valve installation (also see alternate methods, 3.A and 3.B):
 - a. The trip valve should be installed at approximately 1/5 of the scale beam length, measured from the pivot point to the beam stop. Although the trip valve can be installed to operate directly off the scale beam, it is not recommended because of the side play in most scale beams can result in failure to contact the trip valve.



Type N201

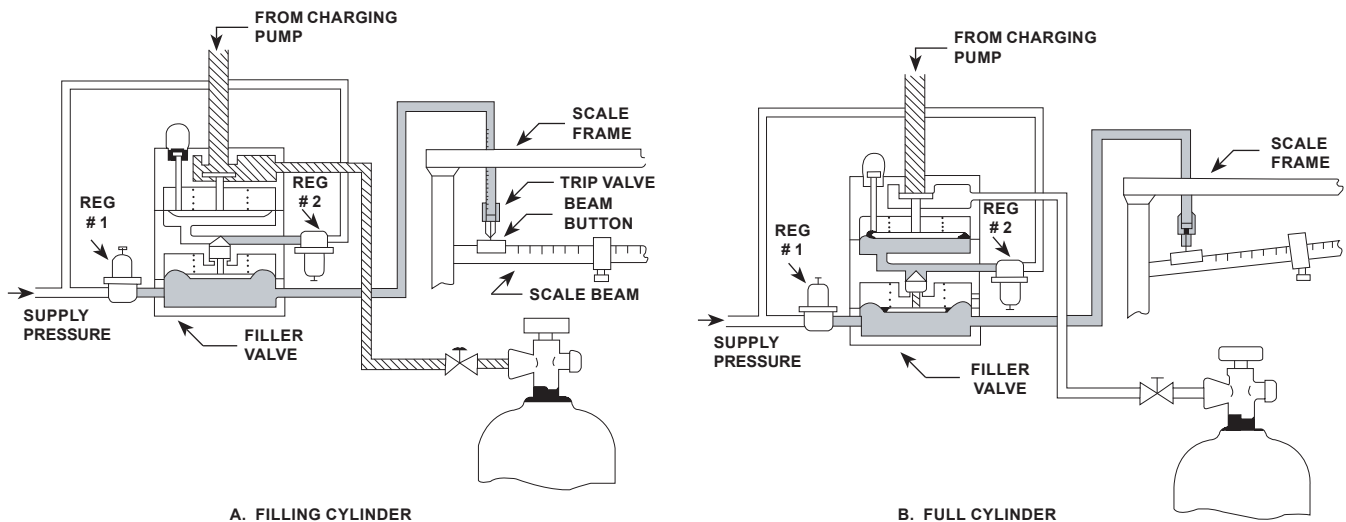

Figure 2. Operational Schematic

- b. Drill a 5/8-inch (16 mm) hole through the scale frame directly above the point on the scale beam, determined in step 3 (a).
- c. Remove locknut "D" and insert trip valve through the 5/8-inch (16 mm) hole. Replace locknut.
- d. Place beam button "J" on the scale beam directly beneath the trip valve.
- e. Using locknuts "D" and "E", position trip valve stem "B" so that it barely contacts beam button "J" with the scale beam in a level position.

CAUTION

Be certain that the beam button cannot contact the trip valve housing at point "A" when the scale beam is in the uppermost position (full cylinder). To correct this, try raising the trip valve slightly and retighten locknuts "D" and "E". If raising the trip valve does not correct the situation the 5/8-inch (16 mm) hole on the scale frame will have to be drilled closer to the pivot point.

- 3.A On installations where the slide weight "H" must be moved to zero, alternate trip valve installation no. 1 can be made. (This is usually necessary when both 20 pounds (9 kg) and 100 pounds (45 kg) cylinders are to be filled.)

Follow steps 3 (a), (b), (c) and:

- d. Place the beam button "J" on the scale beam close enough to the pivot point to allow the slide weight to move to zero. If there is not enough room to permit this, either the beam button must be ground down or the user must make a special beam button.
- e. Mount beam bar "K" on the beam button so that it extends directly under the trip valve. The beam bar can be bent if necessary and extra length can be cut off.
- f. Make certain the beam barely contacts the trip valve stem when the scale beam is in a level position.

- 3.B For Fairbanks Morse Types 1124A and 1280A scales, alternate trip valve installation no. 2 must be made.
 - a. Measure 3-inch (76 mm) from the pivot point as shown.
 - b. Measure 1-1/4-inch (32 mm) from the scale frame center line toward the back of the scale.

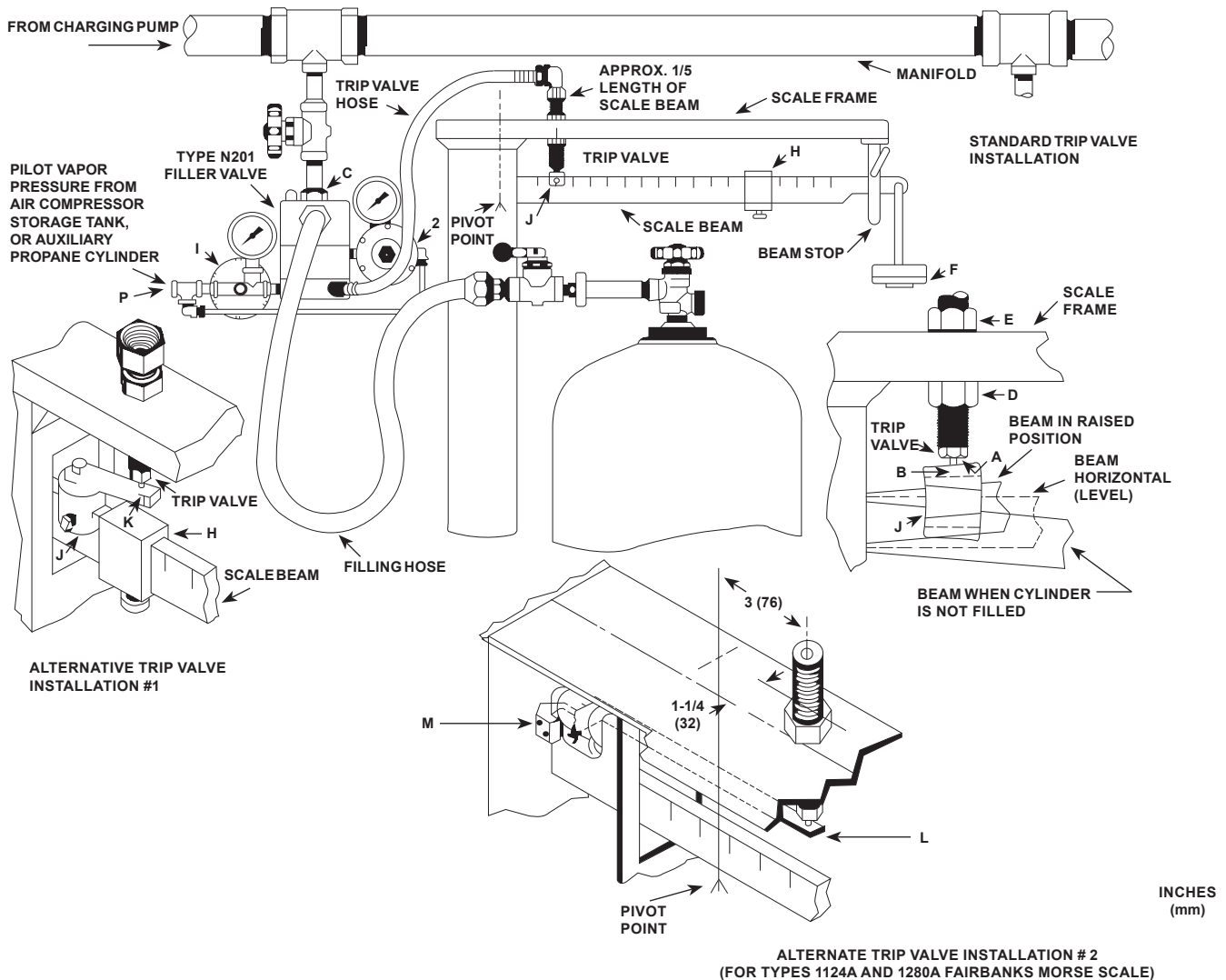

Figure 3. Type N201 Installation

- c. Drill a 5/8-inch (16 mm) hole through the scale frame at this point.
- d. Attach the beam bar "L" to the clamp "M" with two screws, and attach the clamp to the rear of the scale beam with two screws.
- e. Remove locknut "D" and insert the trip valve through the 5/8-inch (16 mm) hole. Replace locknut.
- f. Using locknut "D" and "E", position trip valve so that it barely contacts the beam bar "L" with the scale in a level position.
4. Connect supply pressure (air or gas) at point "P". Recommended supply pressure is at least 30 psig (2,1 bar), since regulator 2 is set at 30 psig (2,1 bar) outlet pressure. A 30 psig (2,1 bar) supply is sufficient for pump discharge pressures up to 350 psig (24,1 bar). Regulator 1 is set at 3 psig (0,21 bar).

Note

If propane vapor pressure is used, atmospheric or room temperature below 8°F (-13°C) will limit supply pressure to below 30 psig (2,1 bar). To assure tight shutoff of the filler valve in this event, refer to Table 1.

Type N201

Table 1. Maximum Supply Pressure and Maximum Recommended Pump Discharge

MINIMUM SUPPLY PRESSURE, PSIG (bar)	MAXIMUM RECOMMENDED PUMP DISCHARGE, PSIG (bar)
21 (1,4)	200 (13,8)
19 (1,3)	150 (10,3)
17 (1,2)	100 (6,9)
14 (0,97)	50 (3,4)
13 (0,90)	25 (1,7)

5. Attach the propane filling hose to one of the filler valve outlets. Plug the other outlet. The filling hose must be complete with a shutoff valve and suitable cylinder valve connection. The filling hose and shutoff valve can be counterbalanced for easy handling if desired.

Operation

1. Place cylinder on scale platform and connect filler hose.
2. Slide beam weight "H" to tare weight stamped on cylinder.
3. Balance scales to compensate for the weight added by the filler hose and shutoff valve. On some scales this can be done by means of a small weight near the beam pivot pin. On others a suitable weight can be added to scale pan "F".
4. Add a 100 pounds (45 kg) weight (or the net weight desired) to scale pan "F", and open the cylinder and hose valve for trial automatic filling operation.
5. Proceed with filling operation until scale beam rises and contacts the trip valve stem. The filler valve will close and the filling operation is complete. This is indicated by the red button on top of the filler valve. Close the hose shutoff valve and the cylinder valve.
6. Check weight of full cylinder on another scale. Balance weight or the weight in scale pan "F" may have to be readjusted slightly until the correct cylinder weight is obtained. Filling accuracy is largely dependent upon the condition of the scale used with Type N201.
7. After the scales have been checked and adjusted, simply position the empty cylinder on the scale, connect the filling hose, slide beam weight "H" to the tare weight stamped on the cylinder, open the hose shutoff valve and the cylinder valve, and the Type N201 will fill the cylinder to the weight added on the scale pan.

Note

When operating with high pump pressure, the filler valve may close off, then reopen for a short spurt and close off again. This is due to the force of the incoming liquid stream. If the proper cylinder weight has been obtained before the additional spurt, the operator should immediately close the hose shutoff valve when the scale beam contacts the trip valve stem. If the scales are balanced after the additional spurt, the operator should wait for this before closing the hose shutoff valve.

In Case of Trouble

1. If sticking of the main (upper) valve should occur, place a few drops of oil below the disk holder (key 5, Figure 4). This can be done with an eye dropper or oil can through one of the outlet ports. Refer to the disassembly instructions if this does not correct the situation.
2. If the disk holder wears out quickly, check the outlet pressure of regulator no. 2. Too high a regulator setting will cause the disk to fail. Refer to step 4 under "Installation".
3. If the trip valve stem "B" should stick, remove the lower trip valve body, and clean out all oil or grease. Polish the seat in the trip valve body by rotating the eraser end of a pencil against the seat 10 or 12 times.

Disassembly

To check disk holder assembly, O-ring, and diaphragms proceed as follows (numbers in parenthesis refer to key numbers in Figure 4):

1. Remove tubing connection from the angle adaptor in Type 67/683 (key 30).
2. Mark the valve body (key 17), valve housing (key 2), and valve head (key 1) so that they can be aligned easily when reassembling.
3. Remove cap screws (key 22).
4. Separate the valve head (key 1), valve housing (key 2), and valve body (key 17). Examine the upper and lower diaphragms (keys 10 and 32). Replace if necessary.

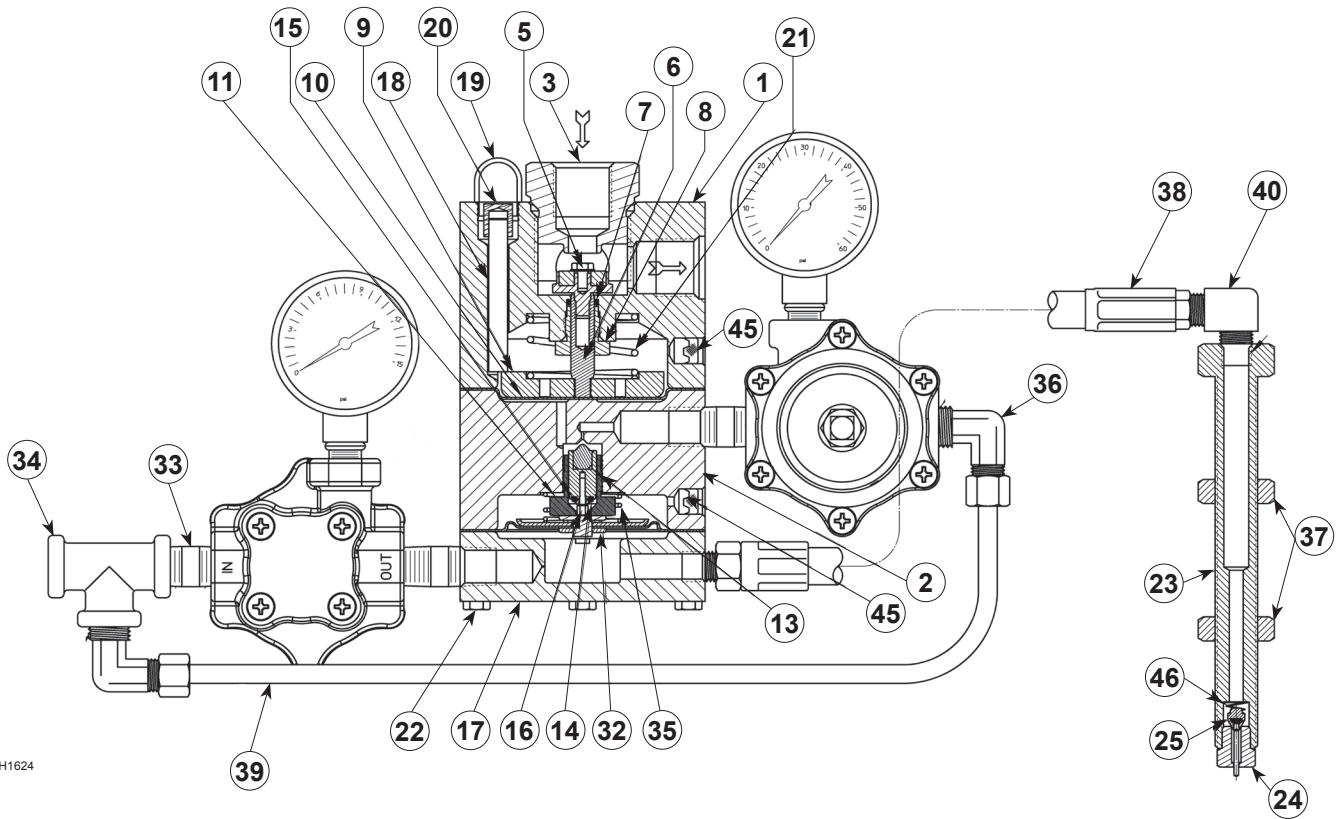

CH1624

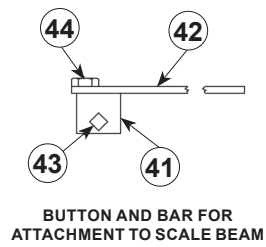

Figure 4. Type N201 Assemblies

Type N201

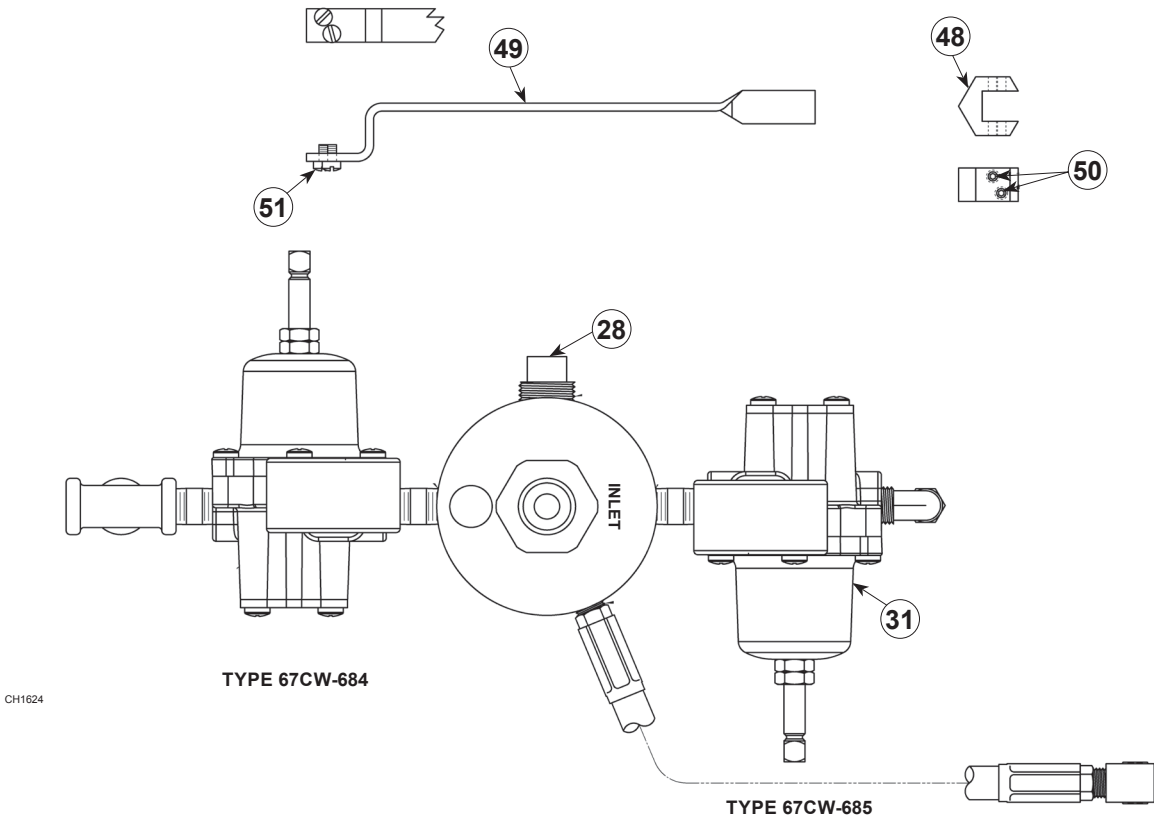

Figure 4. Type N201 Assemblies (continued)

5. Remove orifice (key 3) and unscrew the disk holder assembly (key 5). Examine and replace if necessary.
6. Remove bushing (key 8) and take out the O-ring (key 7). Examine and replace if necessary. Put Dow Corning #3 grease (or equivalent) on the O-ring (key 7).
7. Make sure all parts are clean before reassembling.

To Reassemble

1. Replace orifice (key 3) in valve head (key 1).
2. Replace O-ring (key 7) and screw in bushing (key 8).

3. Replace disk holder assembly (key 5) and spring (key 21). Screw the disk holder into the diaphragm head (key 9).
4. Replace upper diaphragm (key 10) on the valve head (key 1). Align the valve housing (key 2), spring (key 35), lower diaphragm assembly (key 32), and valve body (key 17) so that the cap screws (key 22) can be inserted.
5. Connect tubing (key 39) to angle adaptor in Type 67/683 (key 30).

Parts Ordering

When corresponding with your local Distributor about this equipment, include the type number and all other pertinent information printed on the label. Specify the eleven-character part number when ordering new parts from the following parts list.

Parts List

Key	Description	Part Number	Key	Description	Part Number
1	Valve Head, Aluminum	3C853109022	24	Trip Valve Body, Brass	1F945014012
2	Valve Housing, Aluminum	3F945309022	25	Inner Valve, Brass	20B9389X012
3	Orifice, Brass	1C853314012	28	Pipe Plug, Steel (not shown)	1A3619X0012
5*	Disk Holder Assembly, SST/Nitrile (NBR)/Steel	T10267000A2	32*	Diaphragm Assembly	1H1615000A2
6	Control Valve Stem, 316 SST	1C853735162	33	Pipe Nipple (3 required)	1C488226232
7*	O-Ring, Nitrile (NBR)	T12946T0012	34	Tee, Malleable iron	1C597547362
8	Bushing, Brass	1C853914012	35	Spring, Steel	1F944627212
9	Diaphragm Head, Aluminum	1C854009012	36	Compression Elbow, Brass (2 required)	15A6002X172
10*	Upper Diaphragm, Nitrile (NBR)	1C854102022	37	Nut (2 required)	1H262224122
11	Bushing, Brass	1F944914012	38	Hose Assembly	1J152299012
13	Pilot Valve Assembly, Brass/Nylon (PA)	1F944814012	39	Tubing Assembly, Copper	T20048000A2
14	O-Ring Washer, Brass	1C854514012	40	Street Elbow, Brass	1A429018992
15*	O-Ring, Nitrile (NBR)	T1025806562	41	Beam Button, Aluminum	1H260109012
16	Pilot Valve Stem, 303 SST	1F944735032	42	Beam Bar , Aluminum	1H260210042
17	Valve Body, Aluminum	2F945209022	43	Set Screw, Steel	T1096424152
18	Indicator Rod, Brass	1C854914012	44	Machine Screw, Steel	1B848024052
19	Jewel Clear Lucite, Acrylic plastic	1C855106082	45	Vent Screen, 304 SST (2 required)	0W086343062
20	Indicator Cap, Aluminum	1C855209012	46	Trip Valve Spring, 302 SST	1L139137022
21	Spring, Steel	1C855327022	48	Clamp, Aluminum	1L957309012
22	Cap Screw, Steel (6 required)	1F944524052	49	Beam Bar, Aluminum	1L989910072
23	Trip Valve Stem, Brass	1F945114012	50	Set Screw, 18-8 SST (2 required)	11B8574X012
			51	Machine Screw, Steel (2 required)	1H267528992

*Recommended spare part

Type N201

LP-Gas Equipment

Emerson Process Management Regulator Technologies, Inc.

USA - Headquarters
McKinney, Texas 75070 USA
Tel: 1-800-558-5853
Outside U.S. 1-972-548-3574

For further information visit www.emersonprocess.com/regulators/lp

The Emerson logo is a trademark and service mark of Emerson Electric Co. All other marks are the property of their prospective owners. Fisher is a mark owned by Fisher Controls, Inc., a business of Emerson Process Management.

The contents of this publication are presented for informational purposes only, and while every effort has been made to ensure their accuracy, they are not to be construed as warranties or guarantees, express or implied, regarding the products or services described herein or their use or applicability. We reserve the right to modify or improve the designs or specifications of such products at any time without notice.

Emerson Process Management does not assume responsibility for the selection, use or maintenance of any product. Responsibility for proper selection, use and maintenance of any Emerson Process Management product remains solely with the purchaser.