

Type BM5A Slam-Shut Valve

Table of Contents

Introduction	1
Specifications	2
Principle of Operation	4
Transport and Handling	5
Installation	7
Overpressure Protection	8
Startup	8
Slam-Shut Controller Adjustment	9
Shutdown	9
Maintenance	9
Parts Ordering	11
Spare Parts	11
Parts Lists	13

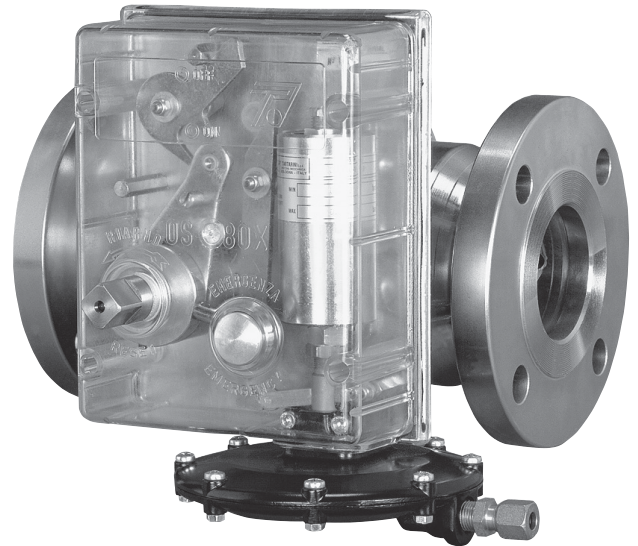

Figure 1. Type BM5A Slam-Shut Valve

WARNING

Failure to follow these instructions or to properly install and maintain this equipment could result in an explosion and/or fire causing property damage and personal injury or death.

Tartarini™ slam-shut valve must be installed, operated and maintained in accordance with federal, state and local codes, rules and regulations and Emerson Process Management Regulator Technologies, Inc. (Emerson) instructions.

If the slam-shut valve vents gas or a leak develops in the system, service to the unit may be required. Failure to correct trouble could result in a hazardous condition.

Call a gas service person to service the unit. Only a qualified person must install or service the slam-shut valve.

Introduction

Scope of the Manual

This Instruction Manual provides instructions for installation, startup, maintenance and spare parts ordering for the Type BM5A slam-shut valves. This manual also contains information for the OS/80X Series slam-shut controller.

Product Description

The Type BM5A slam-shut valves are axial flow type with a single seat and counterbalanced shutter. They are designed for use in high pressure natural gas transmission/city gate stations, large capacity distribution systems and power plant feeds.

They provide smooth and reliable operation, tight shutoff and long life.

Type BM5A

Specifications

The Specifications section gives some general specifications for the Type BM5A slam-shut valve. The nameplates give detailed information for a particular slam-shut valve as built in the factory.

Available Body Sizes

DN 25, 50, 80, 100 and 150 /
NPS 1, 2, 3, 4 and 6

Available End Connection Styles

CL300 RF and CL600 RF

Maximum Allowable Pressure⁽¹⁾

CL300 RF: 51.7 bar / 750 psig
CL600 RF: 103 bar / 1500 psig

Maximum Operating Inlet Pressure (PS_{max})⁽¹⁾⁽²⁾

CL300 RF: 50.0 bar / 725 psig
CL600 RF: 100 bar / 1450 psig

Inlet Pressure Range (b_{pu})⁽¹⁾⁽²⁾

CL300 RF: 0 to 50.0 bar / 0 to 725 psig
CL600 RF: 0 to 100 bar / 0 to 1450 psig

Overpressure Set Range (W_{ao})

CL300 RF: 0.03 to 50.0 bar / 0.44 to 725 psig
CL600 RF: 0.03 to 80.0 bar / 0.44 to 1160 psig

Underpressure Set Range (W_{du})

CL300 RF: 0.01 to 50.0 bar / 0.15 to 725 psig
CL600 RF: 0.01 to 80.0 bar / 0.15 to 1160 psig

Accuracy Class (AG)

Up to $\pm 1\%$

Response Time (t_a)

≤ 1 s

Minimum/Maximum Allowable Temperature (TS)⁽¹⁾⁽²⁾

Class 1: -10 to 60°C / 14 to 140°F
Class 2: -20 to 60°C / -4 to 140°F

Working Temperature Capabilities⁽¹⁾⁽²⁾

**Standard Version, Nitrile (NBR) or
Fluorocarbon (FKM):** -10 to 60°C / 14 to 140°F
Low Temperature Version, Nitrile (NBR):
-20 to 60°C / -4 to 140°F

Available Slam-Shut Controllers

See Table 2

Construction Materials

Slam-Shut Valve

Body: Steel
Shutter: Steel
O-ring: Nitrile (NBR) or Fluorocarbon (FKM)
Pad: Nitrile (NBR) or Fluorocarbon (FKM)
Pad holder: Steel

OS/80X Series Slam-Shut Controller

Body: Aluminum (Types OS/80X-BP and OS/80X-BPA-D) or Steel (Types OS/80X-MPA-D and OS/80X-APA-D)
Diaphragm: Fabric-finished Nitrile (NBR)
O-ring: Nitrile (NBR)

Types OS/84X and OS/88X Slam-Shut Controller

Body: Brass
Lip Seal: Polytetrafluoroethylene (PTFE)
O-ring: Nitrile (NBR)

Types PRX/181-PN, PRX/182-PN, PRX-AP/181-PN and PRX-AP/182-PN Pilots

Body: Steel
Diaphragm: Fabric-finished Nitrile (NBR)
O-ring: Nitrile (NBR)

Slam-Shut Controller and Pilot Connection

1/4 NPT

Approximate Weights

See Table 3

Accessories

- Proximity Switch or Micro Switch for Remote Monitoring
- Solenoid Valve for Remote-controlled Closure
- IT/3V Three-Way Valve for Setting Control

1. The pressure/temperature limits in this Instruction Manual and any applicable standard or code limitation should not be exceeded.

2. Published values are in accordance with EN14382 specifications at average ambient temperature.

This product is designed to be used with fuel gases of 1st and 2nd family according to EN 437 and with other non-aggressive and non-fuel gases. For any other gases, other than natural gas, please contact your local Sales Office.

Use of gas pressure devices (safety shut-off devices - SSD slam-shut type) shall comply with EN 12186 and EN 12279.

Safety slam-shut valves manufactured by Emerson must use additional pressure accessories (e.g. controller or filters) manufactured or approved by Emerson. Emerson is not responsible for any possible inefficiency due to installation of additional pressure accessories not manufactured or approved by Emerson.

When pressure containing parts of safety slam-shut device (SSD) valve and controller have different maximum allowable pressures (PS), the SSD is differential strength type.

TARTARINI APPARECCHIO/ DEVICE TYPE

Note 1

MATRICOLA/ANNO SERIAL Nr./YEAR /Note 2

REAZIONE FAIL SAFE MODE FAIL OPEN FAIL CLOSE

NORME ARMONIZ. HARMONIZED STD. EN

CLASSE DI PERDITA LEAKAGE CLASS TIPO TYPE

CLASSE FUNZIONALE FUNCTIONAL CLASS Note 3

FLUIDO GRUPPO FLUID GROUP 1

TS Note 4 °C PS Note 5 bar PSD Bar PT= 1.5 x PS bar

DN1

DN2

Wds bar

Wdso bar

Wdsu bar

DN sede

DN seat

pdo bar

- Note 1:** See Body Size and End Connection Style
- Note 2:** Year of manufacture
- Note 3:** Class A or Class B
Only valves with overpressure and underpressure settings can be classified in Class A.
- Note 4:** Class 1: -10 to 60°C / 14 to 140°F
Class 2: -20 to 60°C / -4 to 140°F
- Note 5:** Maximum Allowable Pressure (PS)
CL300 RF: 50 bar / 725 psig
CL600 RF: 100 bar / 1450 psig

Figure 2. Type BM5A Slam-Shut Valves Nameplate

Table 1. PED Category for Type BM5A Slam-Shut Valves

PRODUCT SIZE	CATEGORY	FLUID GROUP
DN 25, 50, 80, 100, and 150 / NPS 1, 2, 3, 4, and 6	IV	1

Pressure Equipment Directive (PED) Categories and Fluid Group

According to EN 14382, only in integral strength type and Class A configuration (when both overpressure and underpressure protections are set up) this slam-shut valve can be classified like a safety accessory according to PED.

The minimum PS between SSD valve and controller shall be the PS of the safety accessory to comply the provisions of EN 14382 about integral strength type.

This product, in its Class A and integral strength configuration, is a safety accessory for pressure equipment in the following PED 2014/68/EU categories on Table 1.

Built-in pressure accessories (e.g. controllers Types OS/80 and OS/80-X) conform to PED Article 4 section 3 and were designed and manufactured in accordance with sound engineering practice (SEP).

Per Article 4 section 3, these "SEP" products must not bear the CE marking.

ATEX Requirements



WARNING

If the provisions of EN 12186 and EN 12279, national regulations or any specific manufacturer recommendations are not put into practice before installation and if purge by inert gas is not carried out before equipment's start-up and shut-down operations, a potential external and internal explosive atmosphere can be present in equipment and gas pressure regulating, measuring stations or installations.

If a presence of foreign material in the pipelines is foreseen and purge by inert gas is not carried out, the following procedure is recommended to avoid any possible external ignition source inside the equipment due to mechanical generated sparks:

- Drainage to safe area via drain lines of foreign materials, if any, by inflow of fuel gas with low velocity in the pipe-work (5 m/sec.)

Type BM5A

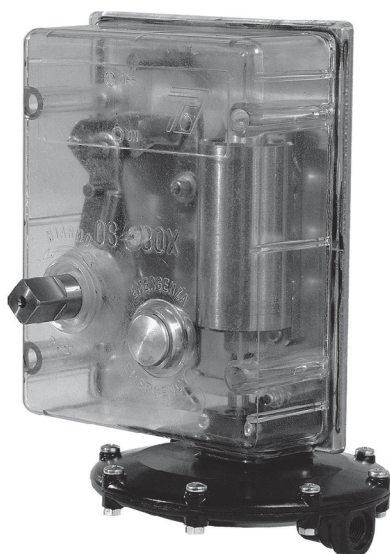

Figure 3. Type OS/80X-BP Slam-Shut Controller

Table 2. OS/80X and OS/80X-PN Series Slam-Shut Controller Details

TYPE	BODY RATING		OVERPRESSURE SET RANGE, W_{Do}				UNDERPRESSURE SET RANGE, W_{Du}				BODY MATERIAL
			Min		Max		Min		Max		
	bar	psig	bar	psig	bar	psig	bar	psig	bar	psig	
OS/80X-BP	5.0	73	0.03	0.44	2.0	29	0.01	0.15	0.60	8.7	Aluminum
OS/80X-BPA-D	20.0	290									
OS/80X-MPA-D	100	1450	0.50	7.25	5.0	73	0.25	3.63	4.0	58	Steel
OS/80X-APA-D			2.0	29	10.0	145	0.30	4.35	7.0	102	
OS/84X			5.0	73	41.0	595	4.0	58	16.0	232	Brass
OS/88X			18.0	261	80.0	1160	8.0	116	70.0	1015	
OS/80X-PN ⁽¹⁾			0.50	7.25	40.0	580	0.50	7.25	40.0	580	Steel
OS/84X-PN ⁽¹⁾			30.0	435	80.0	1160	30.0	435	80.0	1160	Brass

1. **Type OS/80X-PN:** Made of a Type OS/80X-APA-D, set at about 0.4 bar and Type PRX/182-PN pilot for overpressure and Type PRX/181-PN for underpressure as necessary to control the system pressure. **Type OS/84X-PN** (Safety accessory): Made of a Type OS/84X, set at about 20 bar and Type PRX-AP/182-PN pilot for overpressure and Type PRX-AP/181-PN for underpressure as necessary to control the system pressure.

In any case,

- Provisions of Directive 1999/92/EC and 89/655/EC shall be enforced by gas pressure regulating, measuring station or installation's end user.
- With a view to preventing and providing protection against explosions, technical and/or organizational measures appropriate to the nature of the operation shall be taken (e.g.: filling/exhausting of fuel gas of internal volume of the isolated part/entire installation with vent lines to safe area - 7.5.2 of EN 12186 and 7.4 of EN 12279; monitoring of settings with further exhaust of fuel gas to safe area; connection of isolated part/entire installation to downstream pipeline;)
- Provision in 9.3 of EN 12186 and 12279 shall be enforced by pressure regulating/measuring station/ installation's end user.

- External tightness test shall be carried out after each reassembly at installation site using testing pressure in accordance with national rules.
- Periodical check/maintenance for surveillance shall be carried out complying with national regulations, if any, and specific manufacturer recommendations.

Principle of Operation

Slam-Shut Valve

Type BM5A slam-shut valve is made of an axial flow valve and a controller which keeps the valve open in normal conditions. The slam-shut valve features a shutter valve sliding axially, therefore, no by-pass is needed for its opening even in the presence of pressurized gas. This valve can only be opened manually by turning the eccentric shaft counterclockwise.

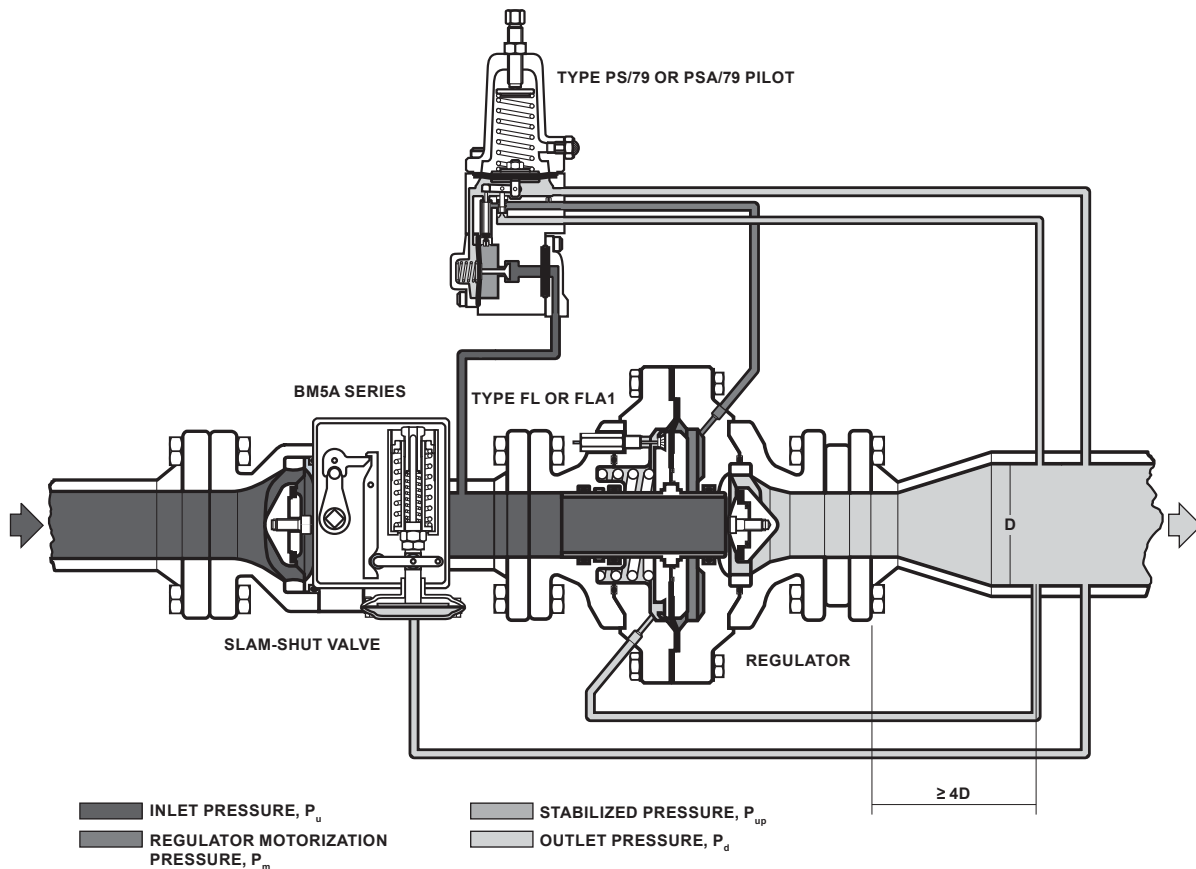

Figure 4. Type BM5A Slam-Shut Valve and Type FL or FLA1 Regulator Operational Schematics

When the controlled pressure is within set values of the slam-shut controller, the controller remains set and prevents the rotation of the eccentric shaft, keeping the valve open. When the controlled pressure varies beyond setting limits, the controller releases the eccentric shaft causing the valve close, following the spring thrust.

The slam-shut controller has a manual release push-button to quickly close the slam-shut valve in case of emergency or during maintenance and checking operations.

If the Type BM5A slam-shut valve is used with pilot-operated pressure regulators, the supply pressure to the pilot is taken from the downstream line of the slam-shut valve. For this purpose, Type BM5A slam-shut valve features a threaded hole which may be used for the supply pressure to the pilot. This hole is normally kept closed by a dowel.

Slam-Shut Controller

The Type BM5A slam-shut valves are equipped with the OS/80X or OS/80X-PN Series slam-shut controller. The controllers are supplied in different models according to set ranges required. The Type BM5A with DN 150 / NPS 6 body size is equipped with a reinforced version Type OS/80X-R.

OS/80X or OS/80X-PN Series slam-shut controller is used to keep the slam-shut valve shutter open. These Series are designed to operate on Overpressure Shutoff (OPSO) only, Underpressure Shutoff (UPSO) only, or Overpressure and Underpressure Shutoff (OPSO/UPSO) protection.

Transport and Handling

Follow established transport and handling procedures to avoid any damage on the pressure-containing parts by shocks or excessive external pressure or stress.

Use appropriate eyebolts to aid in the handling of heavy equipment.

Protect built-up sensing lines and pressure accessories (e.g. slam-shut controller) from shocks or excessive external pressure or stress.

Type BM5A

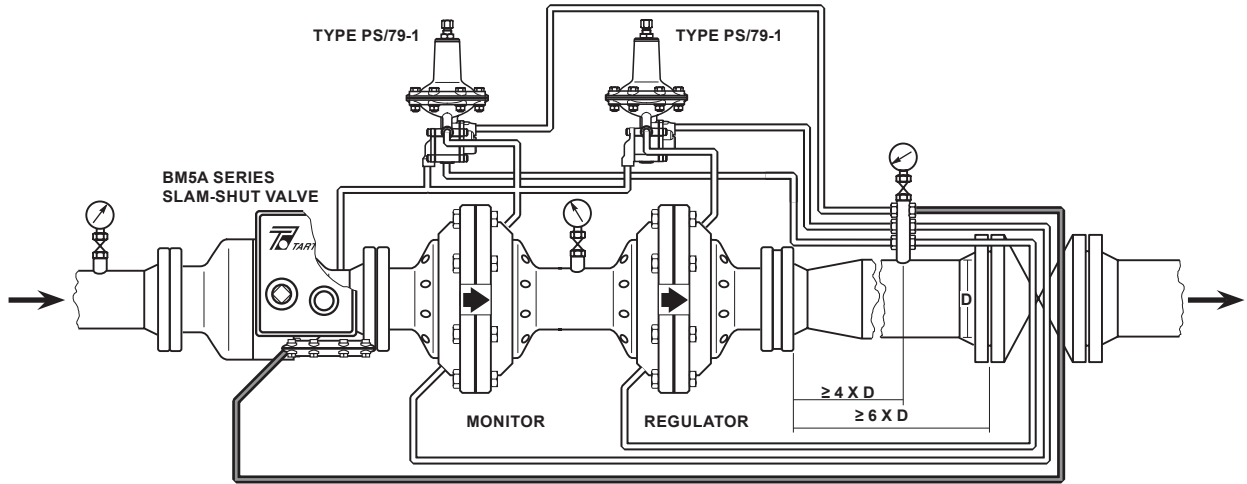

OUTLET PRESSURE

SLAM-SHUT VALVE WITH OS/80X SERIES CONTROLLER - INSTALLATION IN A LOW PRESSURE REGULATING LINE

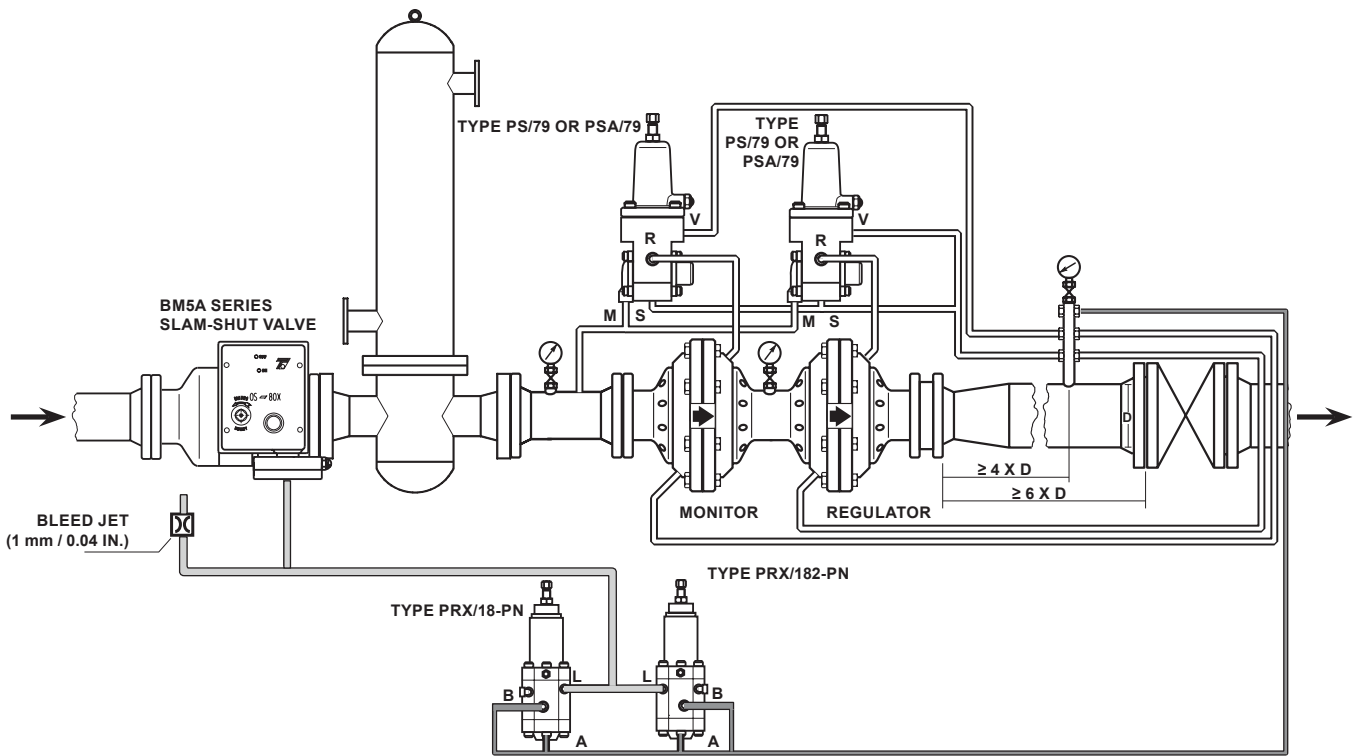

OUTLET PRESSURE
ATMOSPHERIC PRESSURE

PRX SERIES:

B - SUPPLY PORT
L - LOADING PORT
A - SENSING PORT

TYPES PSA/79, PSA/80,
PSA/79-AP AND PSA/80-AP:

V - SENSING PORT
M - SUPPLY PORT
R - LOADING PORT
S - BLEED PORT

SLAM-SHUT VALVE WITH OS/80X-PN SERIES CONTROLLER - OVERPRESSURE AND UNDERPRESSURE CONTROL DOWNSTREAM OF REGULATORS

Figure 5. Type BM5A Typical Connection/Installation Schematics

Installation

WARNING

Personal injury or equipment damage, due to bursting of pressure-containing parts may result if this slam shut valve is overpressured or is installed where service conditions could exceed the limits given in the Specification section and on the appropriate nameplate or where conditions exceed any rating of the adjacent piping or piping connections.

To avoid such injury or damage, provide pressure-relieving or pressure limiting devices to prevent service conditions from exceeding those limits. Also, be sure the installation is in compliance with all applicable codes and regulations.

Additionally, physical damage to the slam shut valve could break the slam shut controller off the main valve, causing personal injury and property damage due to bursting of pressure containing parts. To avoid such injury and damage, install the slam shut valve in a safe location.

Installation procedures performed by unqualified personnel may result in improper adjustment and unsafe operation. Either condition may result in equipment damage or personal injury. Only a qualified person shall install or service the Type BM5A slam shut valve.

General Installation Requirements

CAUTION

Slam shut controller must be mounted as shown in Figure 6. If mounted any other way, the controller will not function properly.

- Follow the provisions of EN 12186 and EN 12279 in installing Type BM5A slam-shut valve:
 - Provide all means of appropriate draining methods in the equipment installed before the slam-shut valve.
 - Provide the cathodic protection and electrical isolation to avoid any corrosion.
 - Clean the gas using proper filters, separators or scrubber to avoid any hazard of erosion or abrasion of pressure containing parts (clause 7.3/7.2).

- Ensure that the data found on the slam-shut valve and slam-shut controller label are compatible with usage requirements.
- Ensure the slam-shut is not damaged and remove all foreign materials that might have collected during shipping. Clean out all pipelines before installing the slam-shut valve.
- Install the slam-shut valve in any position desired, unless otherwise specified, but be sure flow through the body matches the direction indicated by the flow arrow stamped on the valve body.
- Install the slam-shut controller upright.
- Do not apply excessive external pressure or stress on the body during installation.
- Use suitable line gaskets and bolting.
- Check and add any protection suitable for specific environment.
- For outdoor installations, locate the slam-shut devices away from vehicular traffic. Orient it in correct position such that water, ice or other foreign materials cannot enter into the device. Avoid placing the slam-shut valve beneath eaves or downspouts, and be sure it is above the probable snow level. Install slam-shut valve in non-seismic area and places away from fire or lightning.
- To avoid variations in the release values of slam-shut valve and alteration of the trip pressure setpoints of the slam-shut controller, make pressure control line connection in a straight pipe and away from bends, elbows or other areas of turbulent flow.

Minimum and/or Maximum Setting

CAUTION

Whenever minimum or maximum (UPSO or OPSO) pressure setting is not required, omit corresponding steps.

The slam-shut controller is factory set at approximately midpoint of the spring range or at customer specified set pressure. However, a field adjustment may be required to obtain desired results. Perform the following steps to achieve the correct settings.

1. Make sure that the lever (key 33) is in horizontal position when slam-shut controller is reset. If necessary, use nut and locknut (keys 69 and 70) to adjust the lever (see step 2, Reassembly section).

Type BM5A

2. Use maximum (OPSO) adjusting nut (key 50) to completely load maximum pressure (OPSO) spring (key 53). Loosen minimum (UPSO) adjusting screw (key 49) to completely relieve minimum pressure (UPSO) spring (key 54).
3. Disconnect pressure control piping at port A.
4. Through port A, apply pressure to the controller using a pump or other appropriate means and raise the pressure to normal operating level.
5. Reset slam-shut controller. Then, reduce the pressure until it reaches minimum cutoff level.
6. Use minimum (UPSO) adjusting screw (key 49) to load minimum pressure (UPSO) spring (key 54) slowly until the desired cut-off point is achieved.
7. Repeat steps (4) and (5) above to achieve the required setpoint.
8. Bring pressure back to normal values.
9. Reset slam-shut controller. Then, raise the pressure until it reaches maximum cut-off level.
10. Using maximum (OPSO) adjusting nut (key 50), slowly unload maximum pressure (OPSO) spring (key 53) until the desired cut-off point is achieved.
11. Repeat steps (8) and (9) above to achieve the required setpoint.

Overpressure Protection

The recommended maximum allowable pressures are stamped on the slam-shut valve label.

Provide upstream overpressure protection if inlet pressure to slam shut valve can go higher than maximum allowable/operating pressure to downstream equipment.

After slam-shut valve's intervention, inspect the slam-shut valve for damage and maintain downstream side pressure within the actual maximum operating set up range to avoid abnormal back pressures that can damage the SSD's controller.

Provide downstream overpressure protection if the slam-shut valve outlet pressure can be greater than the maximum allowable pressure (PS) of the pilot (differential strength type).

Slam-shut valve operation below the limits specified in the specifications section and slam-shut valve label does not preclude the possibility of damage from external sources or debris in the line.

Startup

WARNING

Remove lever unit (key 137) from reset stem (key 6) of controller immediately after reset and secure it in a safe place. If violated, equipment damage and/or personal injury may result.

CAUTION

To prevent damage to the controller during Startup, the sensing and bleed lines should be located on the same side of the downstream block valve.

When red mark in controller gets to "ON", resetting has been completed. Further operation will damage the controller. Based on structural characteristics, the torque for resetting first increases then decreases with the increase of rotation of handle.

Slam-Shut Valve

Once the slam-shut valve is properly installed, perform the following steps to startup.

1. Partially open the isolation valve located downstream of the regulator enough to allow a minimum gas flow.
2. Partially open isolation valve upstream of the slam-shut valve to let a small amount of gas to flow into the slam shut valve.
3. Turn the reset stem slowly counterclockwise using the appropriate lever unit. This will let gas to flow from inlet to outlet of slam-shut valve.
4. Wait for few seconds for the pressure to stabilize.
5. Repeat step 3 above, making sure that levers of slam-shut controller keep the valve open and that lever (key 33) is in horizontal position.
6. Slowly open the isolation valve upstream of slam-shut valve completely. Then, slowly open the isolation valve downstream of regulator completely.

Slam-Shut Controller Adjustment

Perform the following steps to change the slam-shut controller setpoints (overpressure and/or underpressure).

1. Remove the spring closing cap of the controller.
2. Turn the adjusting screws clockwise to increase setpoint or counterclockwise to decrease setpoint. Monitor set pressure with a test gauge during the adjustment.

Shutdown

WARNING

To avoid personal injury resulting from sudden release of pressure, isolate the slam-shut valve from all pressure and release trapped pressure from the equipment and pressure line before disassembly of equipment. In case of disassembly of pressure retaining parts for checks and maintenance procedures, external and internal tightness tests have to be done according to applicable codes.

Maintenance

WARNING

Only a qualified person may perform maintenance procedures. If necessary, contact our local Sales Office for assistance.

Failure to test the slam-shut device for proper shutoff can result in a hazardous condition. Test the slam-shut device for operation per applicable federal, state, and local codes, rules and regulations, and manufacturer's instructions.

The slam shut valve and its accessories are subject to normal wear and therefore, they must be inspected periodically and replaced if necessary. The frequency of inspection and replacement depends on the severity of service conditions, test results found during the annual test, and applicable codes and regulations. In accordance with applicable National or Industry codes, standards and regulations/recommendations, all hazards covered by specific tests after final assembly

before applying the CE marking, shall also be covered after every subsequent reassembly at installation site, in order to ensure that the equipment will be safe throughout its intended life.

The slam-shut device should be tested for both under and overpressure shutoff activation and seat leak annually with test intervals not to exceed 15 months and at least one each calendar year. If the slam-shut device does not close at the desired set pressure(s) and/or leaks gas after closure, repair and/or replace the slam-shut device.

Slam-Shut Valve (See Figure 7)

WARNING

Only a qualified person may perform maintenance procedures. If necessary, contact our local Sales Office for assistance.

Before proceeding with any maintenance work, stop the fluid flow to the unit. Turn off the isolation valves upstream and downstream of the slam-shut valve. Release pressure from the equipment and control lines.

Disassembly

1. Disconnect all connections, remove slam-shut valve from the line and place it in vertical position (inlet flange at bottom and outlet flange at top). Use appropriate protection method to prevent damage to the flanges and their gasket surfaces.
2. Mark the position of the outlet flange (key 116) and inlet flange (key 100) to keep the same/correct alignment during reassembly.
3. Loosen the special screws (key 133) and dismount the slam-shut controller.
4. Loosen screws (key 135) and remove hub (key 124). Remove seeger ring (key 122) and dismount parts. Replace O-rings [keys 120, 125 and 126 (include key 130 for DN 150 / NPS 6)] and anti-friction rings (key 119). Check bearing [key 128 (include key 131 for DN 150 / NPS 6)] and replace if necessary.
5. Slowly loosen nuts (key 112) to decompress the spring (key 114).
6. Remove sleeve (key 117), disk (key 110) and pad holder (key 101); loosen screw (key 104) and replace pad unit (key 102). Replace O-ring [key 107 (include key 129 for DN 65 / NPS 2-1/2 to DN 150 / NPS 6)].

Type BM5A

7. Replace O-ring (key 115).
8. Check all moving parts, especially nickel plated surfaces. Replace any that are worn or damaged.
9. Clean all stripped-down parts.

Reassembly

Lubricate all seals with silicone-based lubricant and be careful not to damage the seals when reassembling.

Reassemble the parts in the reverse order of the above steps.

As you proceed, make sure that parts move freely and without too much friction.

In addition:

- Complete reassembly and make sure to tighten all screws uniformly.
- When reassembling the hub (key 124), make sure that the pawl of shaft unit (key 121) is facing the inlet flange (key 100).
- Check that slam-shut sleeve (key 117) opens when shaft unit (key 121) is rotated counterclockwise.
- Before reassembling the slam-shut controller, make sure that the pawl of shaft unit (key 121) is against the sleeve (key 117). Ensure that the slam-shut actuator is correctly mounted.
- After reassembling check if all parts are properly functioning. Check the valve with suds to ensure that there are no leaks.
- Reinstall slam shut valve on the line and reestablish all connections.

Slam-Shut Controller (See Figure 8)



WARNING

Only a qualified person may perform maintenance procedures. If necessary, contact our local Sales Office for assistance.

Before proceeding with any maintenance work, disconnect impulse connection (A) to release pressure inside the slam-shut controller.

After maintenance operation, check the tightness of the connections with suds.

Routine slam-shut controller maintenance entails periodic checking of the diaphragm on the Type OS/80X (the piston Gaco flex on the Type OS/84X) and the movement of the levers (the levers should move freely with minimum friction). If necessary, lubricate pins with silicone-based lubricant.

Disassembly

1. Remove screws (key 40) and casing (key 47).
2. Remove dowels (key 12) and bushing (key 13).
3. Slide off stem (key 6), lever assembly (keys 17 and 2), balls (key 10) or rollers for Type OS/80X-R and shim ring (key 15). Wash parts, replace any if worn-out.
4. Remove nuts (key 18), levers (keys 20 and 36) and springs (keys 37 and 21).
5. Remove nut (key 30), screw (key 29) and lever (key 33).
6. Remove minimum (UPSO) adjusting screw (key 49), maximum (OPSO) adjusting nut (key 50) and springs (keys 53 and 54).
7. Remove cover (key 61) on OS/80X Series or plug on Types OS/84X and OS/88X, and proceed as directed in replacing diaphragm/O-ring section.
8. Remove nut (key 70) and locknut (key 69), then slide off stem unit (key 57).
9. Loosen screw (key 3), unscrew nut (key 9), remove balls holder (key 5) and check seals (keys 4 and 8) for wear.
10. Clean all removed parts. Replace any that are worn or damaged.

Replacing Diaphragm (OS/80X Series only)

1. Remove screws (key 27) and cover (key 61).
2. Replace diaphragm (key 62).
3. To remount diaphragm, coat it with grease, set it in place around the edge of cover (key 61) and evenly tighten screws (key 27) to ensure proper sealing.

Replacing O-ring

(Types OS/84X and OS/88X only)

1. Remove plug (key 61) and extract piston (key 68) from body (key 60).
2. Replace O-ring (key 67) and Gaco flex (key 66).
3. Reassemble in the reverse order of the above procedures.

Reassembly

Reassemble all parts in the reverse order of the steps in the disassembly section.

As you proceed, make sure all parts move freely without too much friction. If necessary, lubricate them with silicone-based lubricant.

Make sure to:

1. Screw the nuts (keys 30 and 18) without overtightening them to allow the levers (keys 33, 36 and 20) to move freely without friction.
2. Before mounting minimum (UPSO) spring (key 54), register position of lever (key 33) by means of nut (key 70), locking it into place with locknut (key 69).

Note

The lever (key 33) is in proper position when it is exactly horizontal and in the center of the groove of lever (key 36).

3. Remount lever assembly (keys 17 and 2), balls (key 10) or rollers for Type OS/80X-R, keeping them in their seat with grease and stem (key 6), which is to be turned so the balls/rollers enter their seats. The stem and lever assembly should now be tightly fitted together.
4. Remount bushing (key 13); make sure that the dowels (key 12) are firmly set in the grooves of the stem (key 6).
5. Repeatedly check if pilot resets properly and, lastly, remount minimum (UPSO) spring (key 54).
6. Check controller setting.

Periodical Checks

Perform the following procedures to check that the slam-shut valve is working properly.

Cut-off Test

1. Cut-off the fluid flow to slam shut valve by closing upstream and downstream isolation valves and disconnect the pressure sensing line to port A of slam shut controller. The slam-shut controller should cut-off for minimum pressure (Underpressure Shut-off - UPSO), if set.
2. Through port A, using a small pump or other appropriate means, raise the pressure to normal operating level. Reset slam-shut controller if it was cut-off in step 1.
3. Simulate pressure increase until maximum pressure cutoff value (Overpressure Shut-off – OPSO) is reached. The slam-shut valve should cut-off at this point.
4. Connect the sensing line back to port A of the controller and return the slam shut valve to operating conditions by following the instructions described in the Startup section.

Valve-seal Check

1. Slowly close the downstream isolation valve.
2. Press the “EMERGENCY” button. The slam-shut controller should immediately close and cut-off the flow through the valve.
3. Loosen a connector in the downstream line of the slam-shut valve or of the regulator. Check the connector with soap and water, to make sure there are no leaks; repair the slam-shut valve if necessary.

Parts Ordering

When corresponding with our local Sales Office about this equipment or to order spare parts or kit, always refer to the type of slam-shut valve or slam-shut controller and its serial number.

When ordering replacement parts, reference the key number of each needed part as found in the following parts list.

Spare Parts

Store spare parts in compliance with national standard/rules to avoid over aging or any damage.

Type BM5A

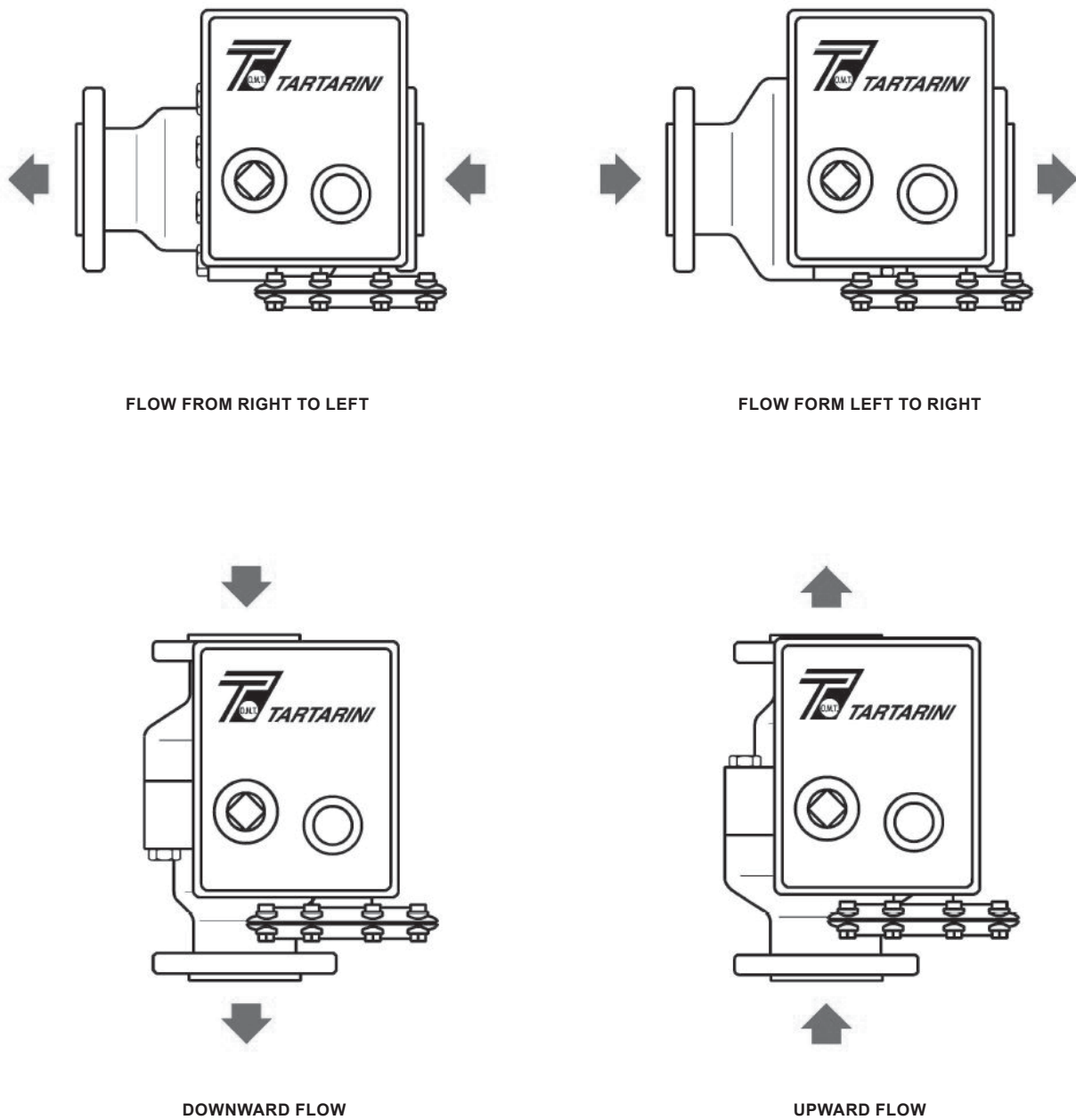

Figure 6. Type BM5A Slam-Shut Valve Flow Orientation

Table 3. Approximate Weights

END CONNECTION STYLE	DN 25 / NPS 1		DN 50 / NPS 2		DN 80 / NPS 3		DN 100 / NPS 4		DN 150 / NPS 6	
	kg	lbs	kg	lbs	kg	lbs	kg	lbs	kg	lbs
CL300 RF / CL600 RF	17	37.5	30	66	62	137	105	231	280	617

Table 4. Troubleshooting Guide for Type BM5A Slam-Shut Valve

SYMPTOMS	POSSIBLE CAUSE	RECOMMENDED ACTIONS
Slam-shut device does not remain set.	The sensing line to port (A) of slam-shut controller is not connected properly.	Check the sensing line connections (A).
	Downstream pressure coincides with the maximum or minimum (OPSO or UPSO) slam-shut settings.	Check slam-shut settings.
	Diaphragm (key 62) [or Gaco flex (key 66) on Types OS/84X and OS/88X] is damaged.	Replace the diaphragm or Gaco Flex.
Sleeve does not seal properly.	Seal gaskets are worn out.	Check gaskets and replace as necessary.
	Sleeve has dirt deposits.	Check sleeve and clean as necessary.
	Shaft unit (key 121) is damaged.	Check shaft unit and repair or replace as necessary.

Parts List

Type BM5A Slam-Shut Valve (See Figure 7)

Key	Description	Key	Description
100	Inlet flange	119*	Anti-friction ring
101	Pad holder	120*	O-ring
102*	Pad unit	121	Shaft unit
103	Pad retainer	122	Seeger ring
104	Screw	123	Pin
105	Label	124	Hub
106	Rivet	125*	O-ring
107*	O-ring	126*	O-ring
108	Label support	127	Disk
109	Label	128	Bearing
110	Disk	129*	O-ring
111	Washer	130*	O-ring
112	Nut	131	Bearing
113	Stud bolt	132	Spacer
114	Spring	133	Special screw
115*	O-ring	134	Bushing
116	Outlet flange	135	Screw
117	Sleeve	136	Eyebolt
118	Screw	137	Lever unit

* Rubber parts are supplied in the "spare parts kit", recommended as stock.

Type BM5A

OS/80X Series Slam-Shut Controller (See Figure 8)

Key	Description	Key	Description
1	Plate	40	Screw
2	Releasing bushing	41	Indicator pin
3	Screw	42	On-Off indicator
4*	Gasket	43	Button
5	Balls holder	44*	O-ring
6	Stem	45	Spring
7	Roller	46	Gasket
8*	O-ring	47	Casing
9	Reloading nut	48	Screw
10	Ball (Roller for Type OS/80X-R)	49	Minimum pressure (UPSO) adjusting screw
11	Roller	50	Maximum pressure (OPSO) adjusting nut
12	Dowels	51	Pipe assembly
13	Reloading bushing	52	Washer
14*	O-ring	53	Spring
15	Ring	54	Spring
17	Reloading lever unit	55	Lower spring holder unit
18	Self-locking nut	56	Seeger ring
19	Washer	57	Stem unit
20	Return lever	58	Spring
21	Spring	59	Plate holding stem unit
22	Fulcrum	60	Top cover (Body for Types OS/84X and OS/88X)
24	Label	61	Lower cover (Plug for Types OS/84X and OS/88X)
26	Nut	62*	Diaphragm
27	Screw	63	Screw
28	Reloading pin	64	Block
29	Screw	65*	O-ring
30	Self-locking nut	66*	Gaco flex
31	Washer	67*	O-ring
32	Plate fulcrum	68	Piston
33	Lever	69	Locknut
34	Screw	70	Nut
35	Cone	71	Microswitch
36	Releasing lever	73*	Gasket (only for Types OS/80X-BP, -BPA-D and -MPA-D)
37	Spring	74	Filter
38	Plug		
39	Locking pin		

* Rubber parts are supplied in the "spare parts kit", recommended as stock.

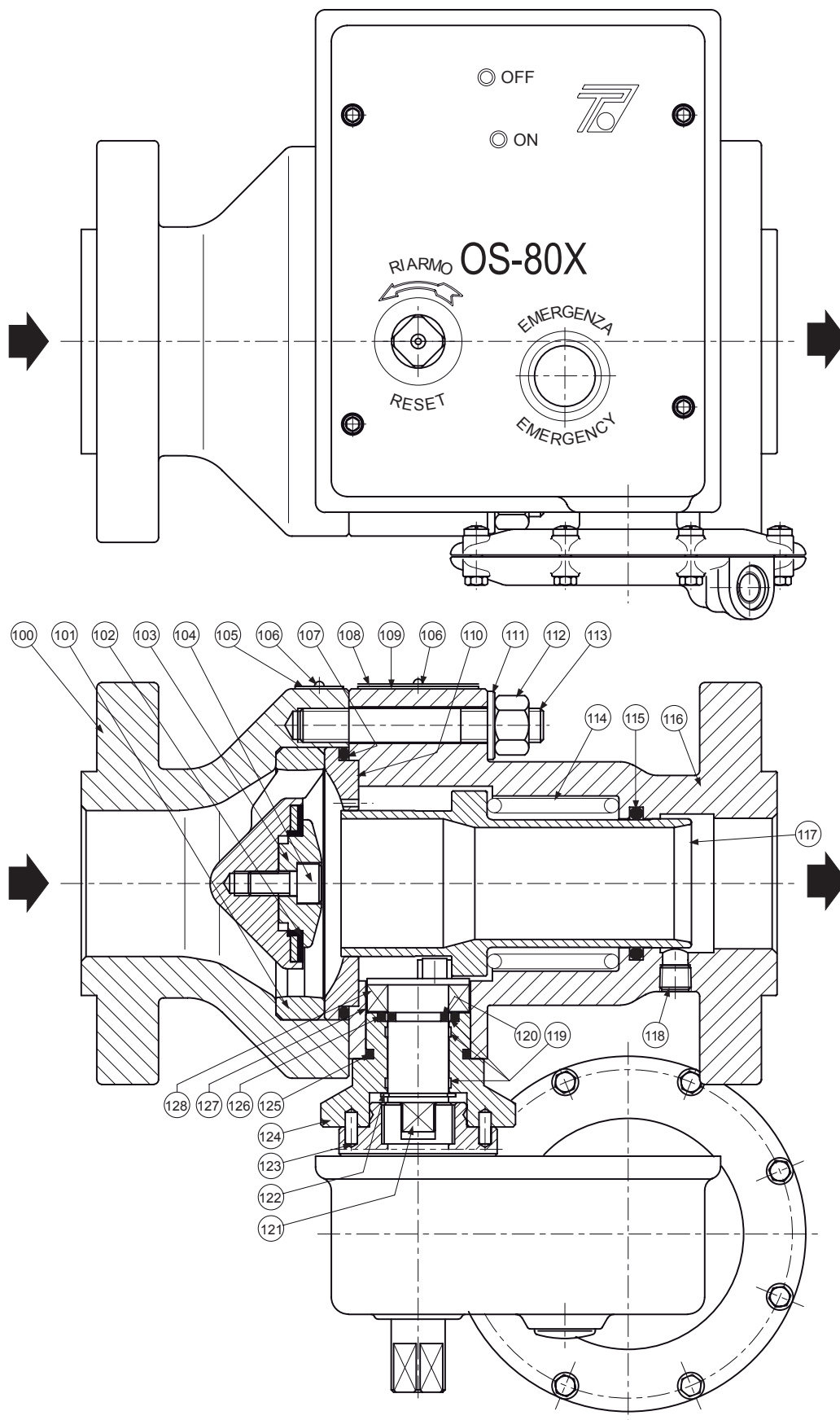
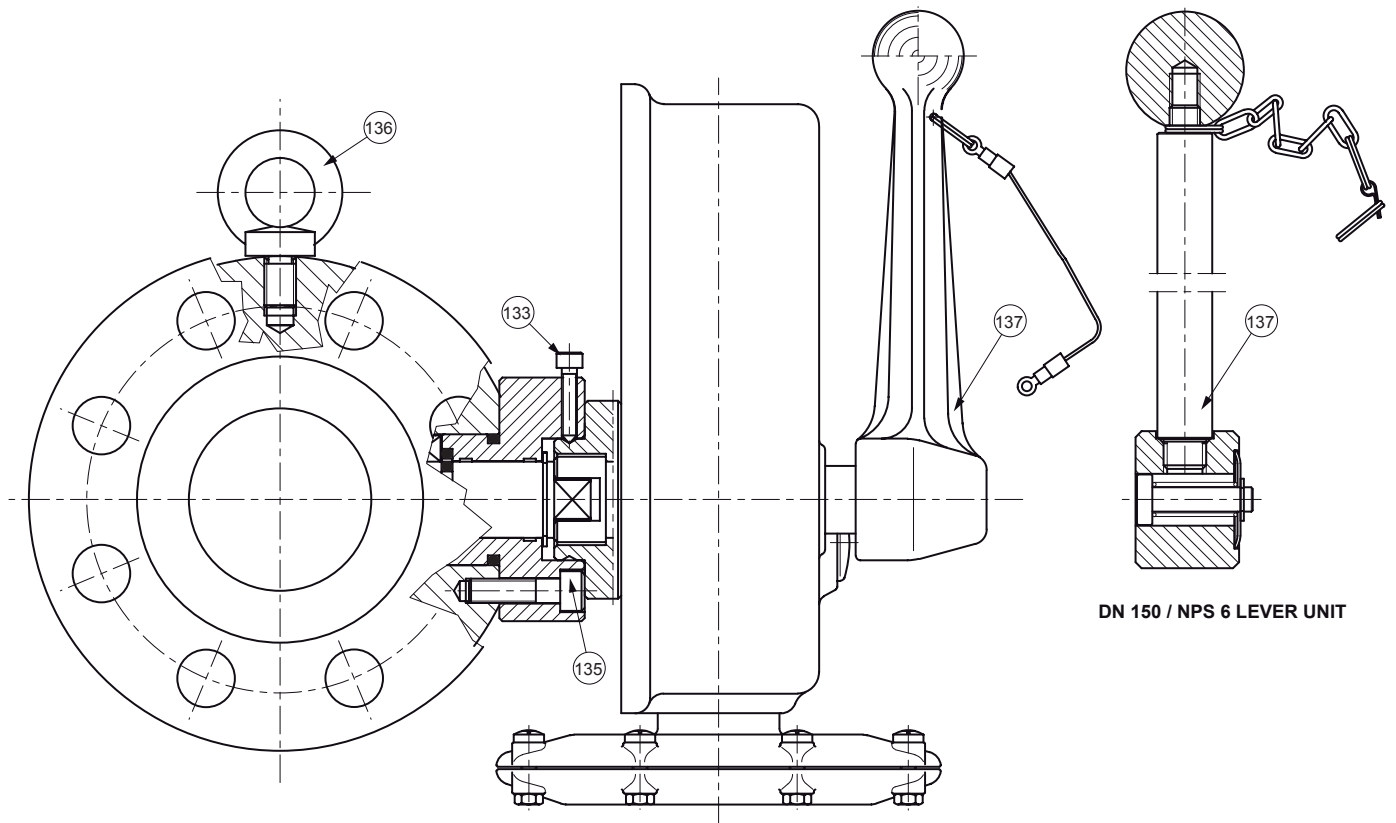

Figure 7. Type BM5A Slam-Shut Valve Assembly

Type BM5A



DN 150 / NPS 6 LEVER UNIT

DN 150 / NPS 6 REOPENING HUB

PAD HOLDER
DN 65 / NPS 2-1/2 TO
DN 150 / NPS 6

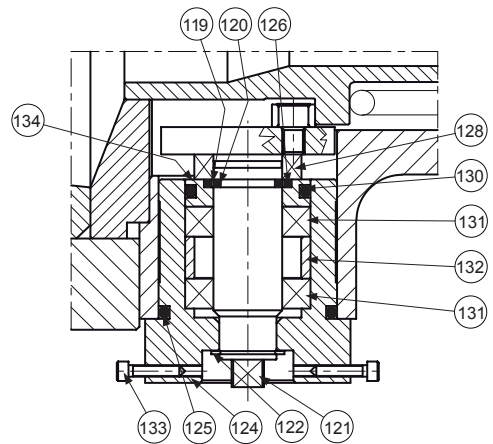
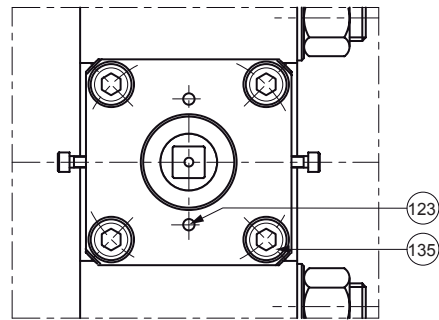
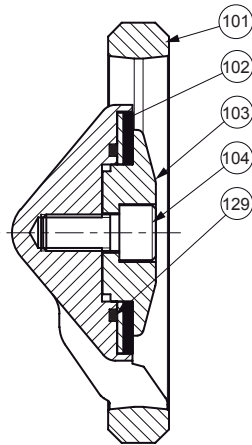

MLM1499

Figure 7. Type BM5A Slam-Shut Valve Assembly (continued)

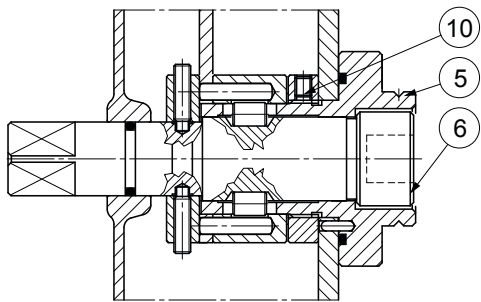

DETAIL OF TYPE OS/80X-R REINFORCED
FOR TYPE BM5A DN 150 / NPS 6

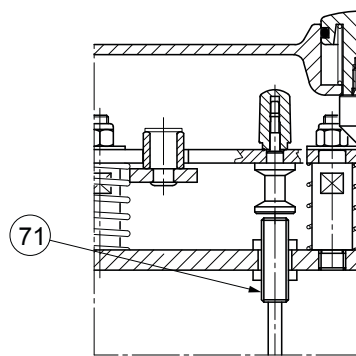

DETAIL OF OS/80X SERIES
WITH PROXIMITY SWITCH

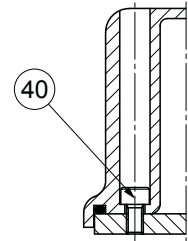

SECTION D-D

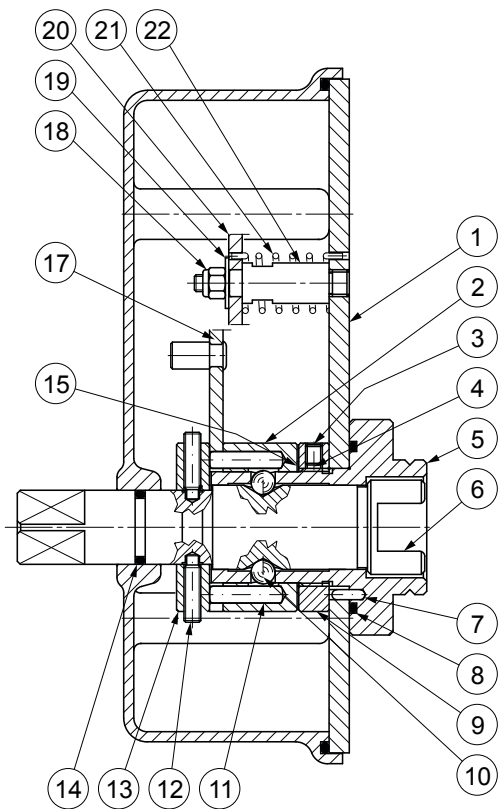

SECTION C-C

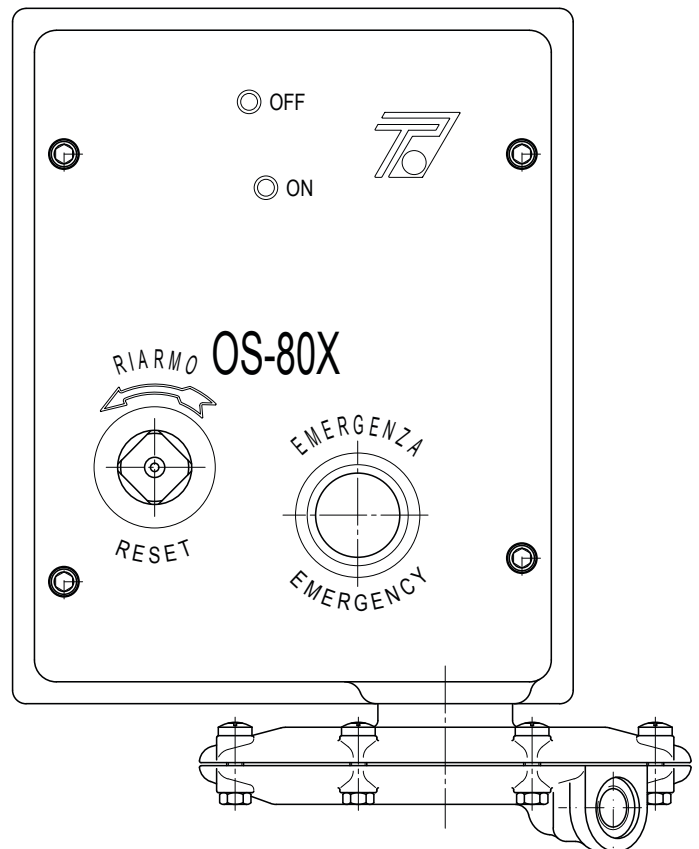

MLM1389

Figure 8. OS/80X Series Slam-Shut Controller Assembly (Standard Version)

Type BM5A

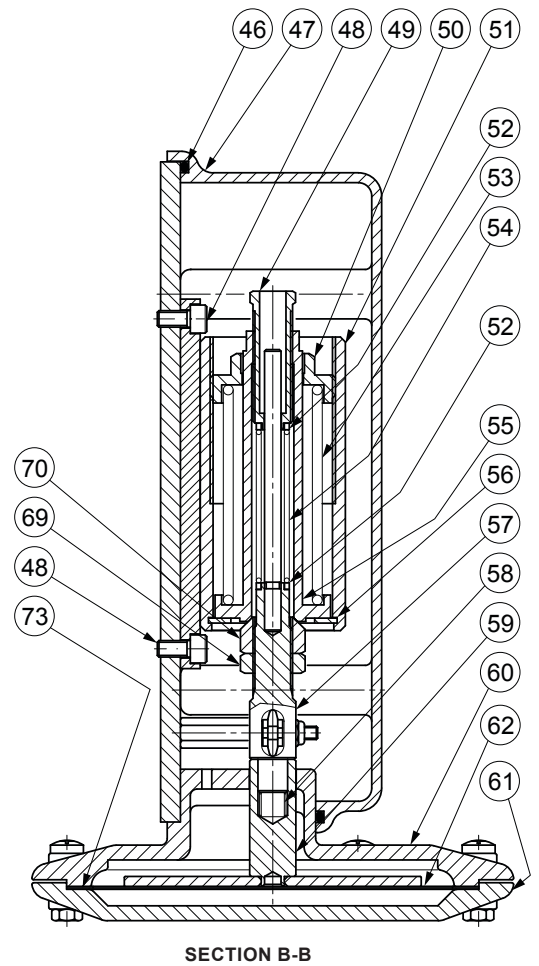
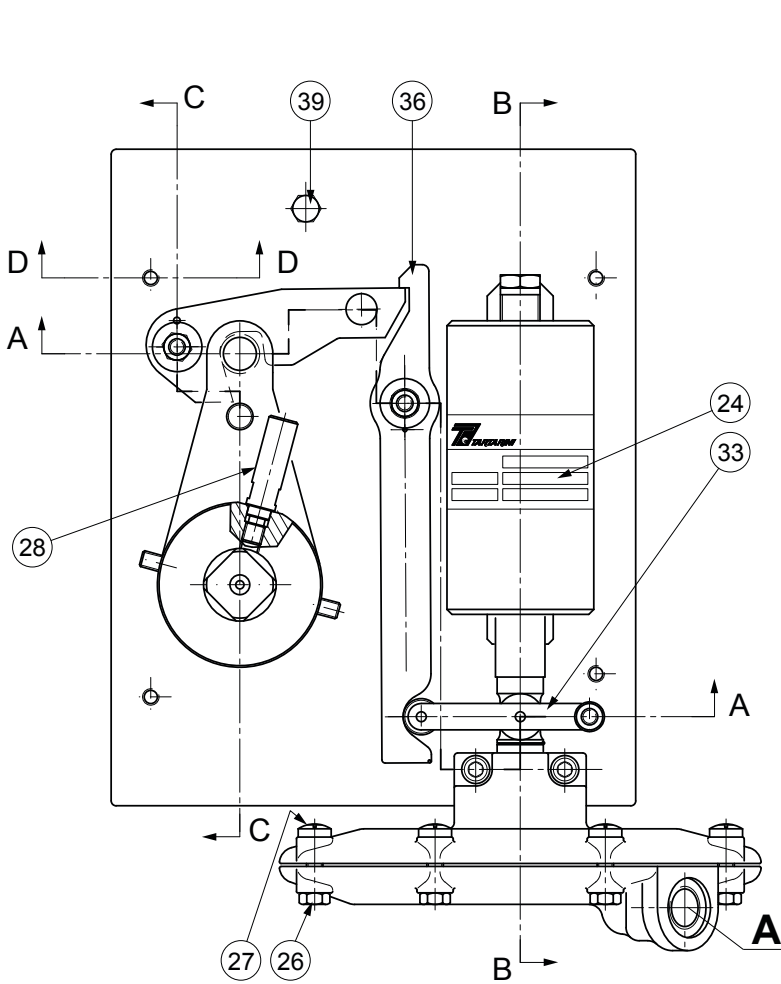
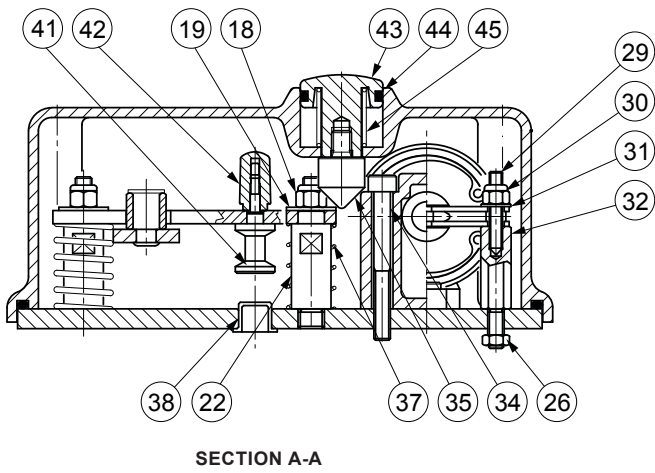
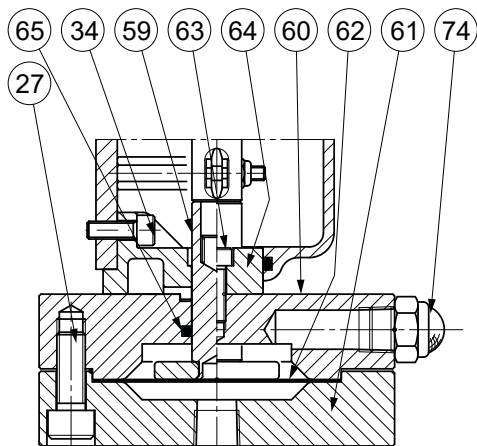
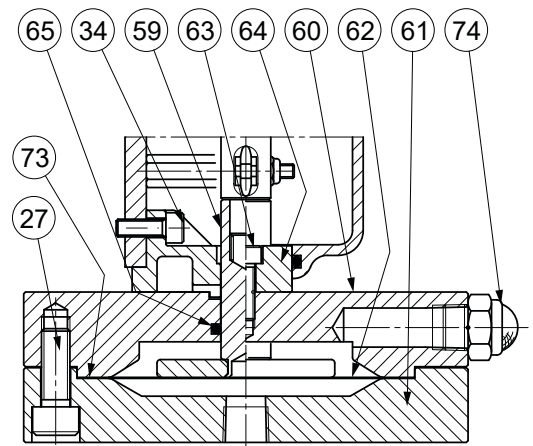

Figure 8. OS/80X Series Slam-Shut Controller Assembly (Standard Version) (continued)

MLM1389



TYPE OS/80X-APA-D DETAIL



TYPE OS/80X-MPA-D DETAIL

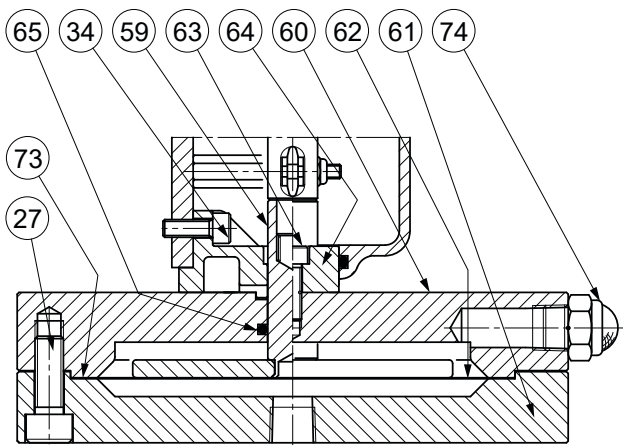

TYPE OS/80X-BPA-D DETAIL

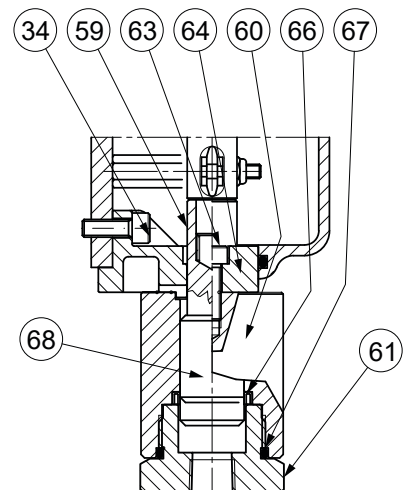

TYPE OS/84X DETAIL

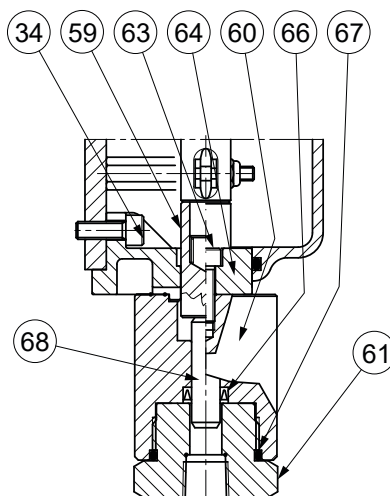

TYPE OS/88X DETAIL

MLM1389

Figure 8. OS/80X Slam-Shut Controller Assembly (Standard Version) (continued)

Type BM5A

 Webadmin.Regulators@emerson.com

 Tartarini-NaturalGas.com

 Facebook.com/EmersonAutomationSolutions

 LinkedIn.com/company/emerson-automation-solutions

 Twitter.com/emr_automation

Emerson Automation Solutions

Americas

McKinney, Texas 75070 USA
T +1 800 558 5853
+1 972 548 3574

Europe

Bologna 40013, Italy
T +39 051 419 0611

Asia Pacific

Singapore 128461, Singapore
T +65 6777 8211

Middle East and Africa

Dubai, United Arab Emirates
T +971 4 811 8100

D103580X012 © 2020, 2021 Emerson Process Management Regulator Technologies, Inc. All rights reserved. 09/21.

The Emerson logo is a trademark and service mark of Emerson Electric Co. All other marks are the property of their prospective owners. Tartarini™ is a mark owned by one of the companies in the Emerson Automation Solutions business unit of Emerson Electric Co.

The contents of this publication are presented for informational purposes only, and while every effort has been made to ensure their accuracy, they are not to be construed as warranties or guarantees, express or implied, regarding the products or services described herein or their use or applicability. All sales are governed by our terms and conditions, which are available upon request. We reserve the right to modify or improve the designs or specifications of such products at any time without notice.

Emerson Process Management Regulator Technologies, Inc does not assume responsibility for the selection, use or maintenance of any product. Responsibility for proper selection, use and maintenance of any Emerson Process Management Regulator Technologies, Inc. product remains solely with the purchaser.

Emerson Process Management s.r.l.

Emerson Automation Solutions - Stabilimento di/Site of: Castel Maggiore - Bologna
Sede Legale/Legal Entity: Piazza Meda 5, 20121 Milano, Italy
Sede Amministrativa/Administrative Headquarters: OMT Tartarini, Via Clodoveo Bonazzi 43,
40013 Castel Maggiore (Bologna), Italy
C.F. - P.I. e R.I. di MI 13186130152 - REA di MI/n.1622916
Direz. e Coord. (art. 2497 bis CC): EMERSON ELECTRIC CO. St. Louis (USA) Socio Unico

