

## Introduction

This installation guide provides instructions for installation, startup and adjustment. To receive a copy of the instruction manual, contact your local Sales Office or view a copy at [www.fisher.com](http://www.fisher.com). For further information refer to: Type Y696 Instruction Manual, D101770X012.

## PED/PE(S)R Categories

This product may be used as a safety accessory with pressure equipment in the following categories. It may also be used outside of these Directives using Sound Engineering Practice (SEP) per table below. For information on the current PED/PE(S)R revision, see Bulletin: [D103053X012](#).

PRODUCT SIZE	CATEGORIES	FLUID TYPE
DN 40 and 50 / NPS 1-1/2 and 2	I	1

## Specifications

### Body Sizes and End Connection Styles<sup>(1)</sup>

See Table 1

### Maximum Allowable Inlet and Outlet Pressures<sup>(1)</sup>

1.0 bar / 15 psig

### Proof test Pressure

All Pressure Retaining Components have been proof tested per Directive.

### Control Pressure Ranges<sup>(1)</sup>

See Table 2

### Temperature Capabilities<sup>(1)</sup>

**Nitrile (NBR):** -29 to 82°C / -20 to 180°F

**Fluorocarbon (FKM):** 4 to 149°C / 40 to 300°F

**Perfluoroelastomer (FFKM):** -18 to 149°C / 0 to 300°F

**Ethylenepropylene (EPDM):** -29 to 135°C / -20 to 275°F

## Installation



### WARNING

Only qualified personnel should install or service a backpressure regulator. Backpressure regulators should be installed, operated and maintained in accordance with international and applicable codes and regulations and Emerson Process Management Regulator Technologies Inc. instructions.

If the regulator vents fluid or a leak develops in the system, it indicates that service is required. Failure to take the backpressure regulator out of service immediately may create a hazardous condition.

Personal injury, equipment damage or leakage due to escaping fluid or bursting of pressure-containing parts may result if this backpressure regulator is overpressured or is installed where service conditions could exceed the limits given in the Specifications section, or where conditions exceed any ratings of the adjacent piping or piping connections.

To avoid such injury or damage, provide pressure-relieving or pressure-limiting devices (as required by the appropriate code, regulation or standard) to prevent service conditions from exceeding limits.

Additionally, physical damage to the backpressure regulator could result in personal injury and property damage due to escaping fluid. To avoid such injury and damage, install the backpressure regulator in a safe location.

Clean out all pipelines before installation of the regulator and check to be sure the regulator has not been damaged or has collected foreign material during shipping. For NPT bodies, apply pipe compound to the external pipe threads. For flanged bodies, use suitable line gaskets and approved piping and bolting practices. Install the backpressure regulator in any position desired, unless otherwise specified, but be sure flow through the body is in the direction indicated by the arrow on the body.

### Note

It is important that the backpressure regulator be installed so that the vent hole in the spring case is unobstructed at all times. For outdoor installations, the backpressure regulator should be located away from vehicular traffic and positioned so that water, ice and other foreign materials cannot enter the spring case through the vent. Avoid placing the backpressure regulator beneath eaves or downspouts, and be sure it is above the probable snow level.

1. The pressure/temperature limits in this installation guide and any applicable standard or code limitation should not be exceeded.

# Type Y696

**Table 1. Body Sizes and End Connection Styles**

BODY SIZE		BODY MATERIAL			
DN	In.	Cast Iron	Steel	Stainless Steel	Hastelloy® C
40 and 50	1-1/2 and 2	NPT	NPT, SWE, CL150 RF, CL300 RF, PN 16/25/40	NPT, SWE, CL150 RF, CL300 RF, PN 16/25/40	CL150 RF

**Table 2. Control Pressure Ranges**

CONTROL PRESSURE RANGE		SPRING COLOR
mbar	In. w.c.	
5 to 12 <sup>(1)(2)</sup> 12 to 37 <sup>(1)(2)</sup> 20 to 69	2 to 5 <sup>(1)(2)</sup> 5 to 15 <sup>(1)(2)</sup> 8 in. w.c. to 1 psig	Red Gray Dark Green
69 mbar to 0.19 bar 0.14 to 0.24 bar 0.28 to 0.48 bar	1 to 2.8 psig 2 to 3.5 psig 4 to 7 psig	Orange Green stripe Red

1. Spring ranges based on spring case installed pointed down. When installed pointed up, spring range increases 5 mbar / 2 in. w.c.  
2. Do not use Fluorocarbon (FKM) diaphragm with these springs at diaphragm temperatures lower than 16°C / 60°F.

## Overpressure Protection

Maximum inlet pressures depend upon body materials and temperatures. Refer to the nameplate for the maximum inlet pressure of the valve. The valve should be inspected for damage after any overpressure condition. **Fisher™ backpressure regulators are not ASME safety relief valves.**

## Startup

The backpressure regulator is factory set at approximately the midpoint of the spring range or the pressure requested, so an initial adjustment may be required to give the desired results. With proper installation completed and relief valves properly adjusted, slowly open the upstream and downstream shutoff valves.

## Adjustment

To change the control pressure, remove the closing cap or loosen the locknut and turn the adjusting screw clockwise to increase control pressure or counterclockwise to decrease pressure. Monitor the control pressure with a test gauge during the adjustment. Replace the closing cap or tighten the locknut to maintain the desired setting.

## Taking Out of Service (Shutdown)



**To avoid personal injury resulting from sudden release of pressure, isolate the backpressure regulator from all pressure before attempting disassembly.**

## Parts List

Key	Description
1	Control Spring
2	Adjusting Screw
3	Closing Cap
4	Lower Control Spring Seat
5*	Diaphragm
6	Lower Diaphragm Plate
7	Diaphragm Plate Gasket
8	Pusher Post
9	Lever Assembly
11	Machine Screw
13	Stem
14*	Cotter Pin
16*	Body Gasket
17	Split Ring
19	Union Nut
20	Lower Casing
21	Diaphragm Case Cap Screw
22	Hex Nut
23	Spring Case
24	Diaphragm Plate
25*	Disk Assembly
27	Orifice
28	Body
29	Pipe Plug
30	Diaphragm Cap Screw
35*	Closing Cap Gasket
38	Body Cap Assembly
40	Disk Shut-Off Stem
41	Disk Spring
44	Upper Spring Seat
46	Valve Disk Washer
47	Disk Screw
50	Nameplate
51	Drive Screws
75	Bushing
78	Pipe Plug

\*Recommended spare part

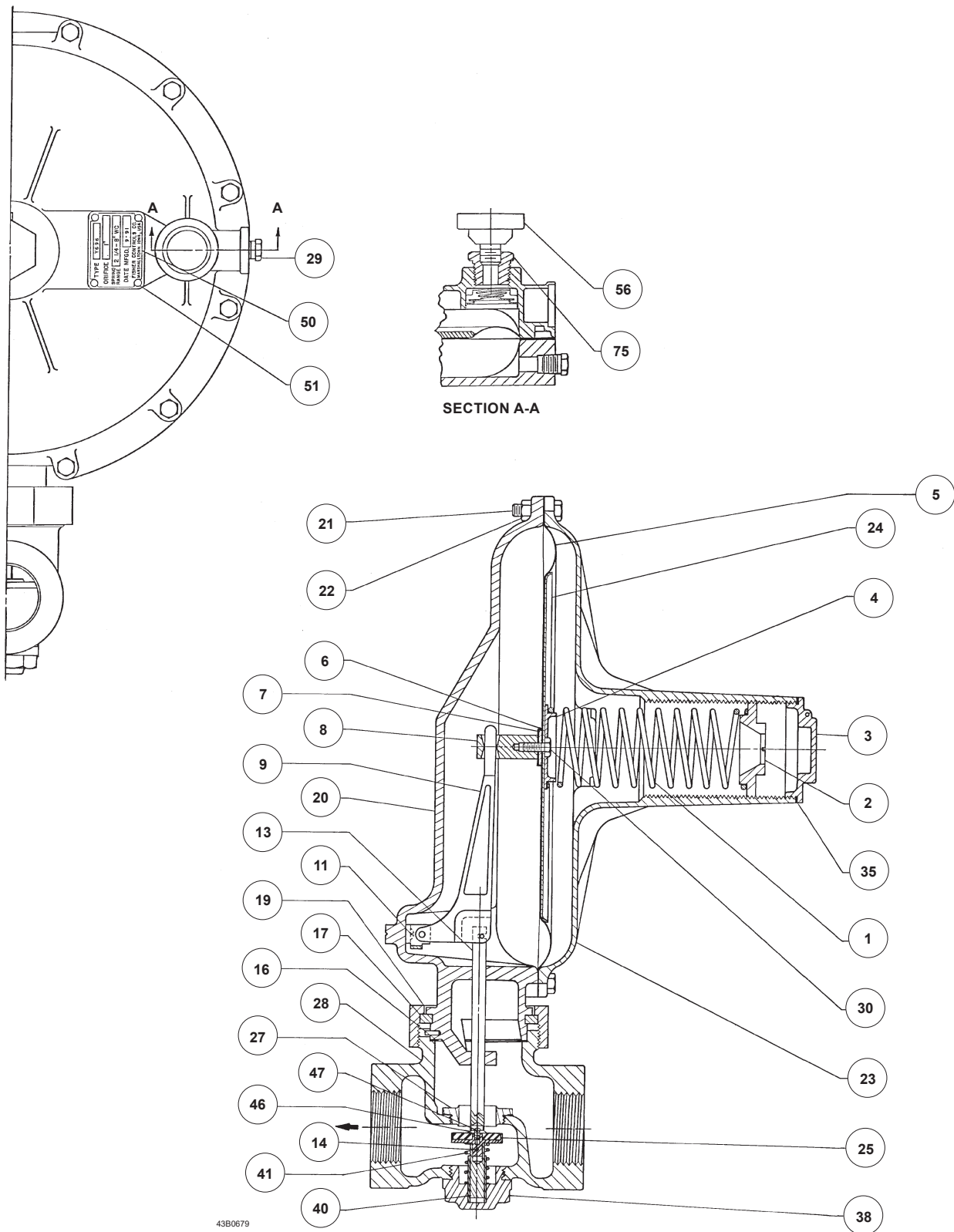

Figure 1. Type Y696 Assembly

# Type Y696

---

✉ [Webadmin.Regulators@emerson.com](mailto:Webadmin.Regulators@emerson.com)

🔍 [Fisher.com](http://Fisher.com)

📘 [Facebook.com/EmersonAutomationSolutions](https://Facebook.com/EmersonAutomationSolutions)

🌐 [LinkedIn.com/company/emerson-automation-solutions](https://LinkedIn.com/company/emerson-automation-solutions)

🐦 [Twitter.com/emr\\_automation](https://Twitter.com/emr_automation)

## Emerson Automation Solutions

### Americas

McKinney, Texas 75070 USA  
T +1 800 558 5853  
+1 972 548 3574

### Europe

Bologna 40013, Italy  
T +39 051 419 0611

### Asia Pacific

Singapore 128461, Singapore  
T +65 6777 8211

### Middle East and Africa

Dubai, United Arab Emirates  
T +971 4 811 8100

D101770X014 © 2002, 2018 Emerson Process Management Regulator Technologies, Inc. All rights reserved. 12/18.  
The Emerson logo is a trademark and service mark of Emerson Electric Co. All other marks are the property of their prospective owners. Fisher™ is a mark owned by Fisher Controls International LLC, a business of Emerson Automation Solutions.

The contents of this publication are presented for informational purposes only, and while every effort has been made to ensure their accuracy, they are not to be construed as warranties or guarantees, express or implied, regarding the products or services described herein or their use or applicability. All sales are governed by our terms and conditions, which are available on request. We reserve the right to modify or improve the designs or specifications of our products at any time without notice.

Emerson Process Management Regulator Technologies, Inc does not assume responsibility for the selection, use or maintenance of any product. Responsibility for proper selection, use and maintenance of any Emerson Process Management Regulator Technologies, Inc. product remains solely with the purchaser.



For further information on the current PED/PE(S)R revision see Bulletin: [D103053X012](#) or scan the QR code.

