

Assembly & Operating Instructions

Compact Rotary Modules

CR 12 | CR 16 | CR 20



Translation of the Original Assembly Instructions EN

- CR 12 ⇒ Order no.: 50112939
- CR 12-ZA ⇒ Order no.: 50112940
- CR 16 ⇒ Order no.: 50112941
- CR 16-ZA ⇒ Order no.: 50112942
- CR 20 ⇒ Order no.: 50112943
- CR 20-ZA ⇒ Order no.: 50112945

Dear Customer,

Thank you for choosing our products and placing your trust and confidence in our company!

These assembly and operating instructions contain all essential information you need about your product. Our aim is to provide the required information as concisely and clearly as possible. If, however, you still have any questions on the contents or suggestions, please do not hesitate to contact us. We are always grateful for any feedback.

Our team will also be glad to answer any further question you may have regarding the rotary module or other options.

We wish you every success with our products!

With kind regards

Your Afag team

© Subject to modifications

The rotary modules have been designed by Afag Automation AG according to the state of the art. Due to the constant technical development and improvement of our products, we reserve the right to make technical changes at any time.

Updates of our documentations



Unlike the printed documents, our digital instructions manuals, product data sheets and catalogues are being continuously updated on our website.

Please keep in mind that the digital documents on our website are always the latest versions.

© Copyright 2021 Afag Automation AG

All contents of the present assembly and operating instructions, in particular the texts, photographs and graphics, are protected by copyright. All rights reserved. No part of these assembly and operating instructions may be reproduced, distributed (made available to third parties), or transmitted in any form or by any means, including photocopying, recording, or other electronic or mechanical methods, without the prior written permission of Afag Automation AG.

Afag Automation AG
Luzernstrasse 32
CH-6144 Zell (Switzerland)
Tel.: +41 62 959 86 86
e-mail: sales@afag.com
Internet: www.afag.com

Table of contents

1	General	6
1.1	Contents and purpose of these assembly instructions.....	6
1.2	Explanation of symbols.....	6
1.3	Additional symbols.....	7
1.4	Applicable documents	8
1.5	Warranty	8
1.6	Liability.....	8
2	Safety instructions	9
2.1	General	9
2.2	Intended use.....	9
2.3	Foreseeable misuse	9
2.4	Obligations of the operator and the personnel	10
2.4.1	Observe the assembly instructions	10
2.4.2	Obligations of the operating company.....	10
2.4.3	Obligations of the personnel	11
2.5	Personnel requirements	11
2.5.1	Personnel qualification	11
2.6	Personal protective equipment (PPE)	12
2.7	Changes and modifications	12
2.8	General hazards / Residual Risks	13
2.8.1	General hazards at the workplace	13
2.8.2	Danger due to electricity	14
2.8.3	Mechanical hazards	14
2.8.4	Danger due to pneumatics	15
2.8.5	Danger caused by omitting maintenance work	15
3	Technical data	16
3.1	Rotary module CR 12.....	16
3.1.1	Dimensional drawing CR 12.....	16
3.1.2	Technical data CR 12.....	17
3.1.1	Preferred combinations CR 12.....	18
3.1.2	Module loads CR 12.....	19
3.1.3	Load diagrams CR 12	20
3.2	Rotary module CR 16.....	21
3.2.1	Dimensional drawing CR 16.....	21
3.2.2	Technical data CR 16.....	22
3.2.3	Preferred combinations CR 16.....	23
3.2.4	Module loads CR 16.....	24
3.2.5	Load diagrams CR 16	25
3.3	Rotary module CR 20.....	26
3.3.1	Dimensional drawing CR 20.....	26

3.3.2	Technical data CR 20.....	27
3.3.3	Preferred combinations CR 20.....	28
3.3.4	Module loads CR 20.....	29
3.3.5	Load diagrams CR 20.....	30
4	Transport, Packaging and Storage	31
4.1	Safety instructions for transport.....	31
4.2	Scope of supply	31
4.3	Transport	32
4.4	Packaging.....	32
4.5	Storage	33
5	Structure and description	34
5.1	Construction rotary modules	34
5.2	Product description.....	34
5.3	Accessories	35
5.3.1	Accessories CR 12, CR 16, CR 20	35
5.3.2	Other accessories CR 12, CR 16, CR 20	35
5.4	Fields of application.....	36
6	Installation, assembly & setting	37
6.1	Safety instructions for installation & assembly	37
6.2	Installation and assembly	38
6.2.1	Assembly and attachment.....	38
6.2.2	Tightening torques for screws	40
6.2.3	Connection to the pneumatic system.....	40
6.2.4	Assembling, monitoring, replacement of the sensors	42
6.3	Settings.....	44
6.3.1	Safety notes for settings.....	44
6.3.2	Adjusting the angle of rotation.....	45
6.3.3	Setting of the end positions	46
6.3.4	Setting of the end position damping.....	46
6.3.5	Adjusting the shock absorber	47
6.3.6	Setting of intermediate positions	48
6.3.7	Approaching the intermediate positions	49
7	Commissioning	50
7.1	Safety instructions for commissioning	50
7.2	Commissioning of the modules	50
8	Fault elimination.....	51
8.1	General notes	51
8.2	Safety instructions for troubleshooting	51
8.3	Table Fault causes and remedy	51
8.3.1	Troubleshooting table.....	51

9	Maintenance and repair	52
9.1	General notes	52
9.2	Safety instructions for maintenance and repair	52
9.3	Maintenance activities and maintenance intervals	53
9.3.1	Overview of the maintenance points	53
9.3.2	Compressed air specifications	54
9.3.3	Further maintenance	55
9.4	Spare parts and repair work	55
10	Decommissioning, disassembly, disposal.....	56
10.1	Safety instructions for decommissioning, disassembling and disposal.....	56
10.2	Decommissioning	56
10.3	Disassembly	56
10.4	Disposal.....	57
11	Declaration of incorporation	58

1 General

1.1 Contents and purpose of these assembly instructions

These assembly instructions contain important information on assembly, commissioning, functioning and maintenance of the rotary modules **CR 12**, **CR 16**, **CR 20** to ensure safe and efficient handling and operation.

Consistent compliance with these assembly instructions will ensure:

- permanent operational reliability of the rotary module,
- optimal functioning of the rotary module,
- timely detection and elimination of defects (thereby reducing maintenance and repair costs),
- prolongation of the rotary module service life.

The illustrations in this manual shall provide you with a basic understanding of the module and may vary from the actual design of your module.

1.2 Explanation of symbols

The safety notes are marked by a pictogram and a signal word. The safety notes describe the extent of the hazard.

DANGER



Danger!

This safety note indicates an imminently hazardous situation which, if not avoided, will result in death or serious injury.

WARNING



Warning!

This safety note points out a potentially hazardous situation which, if not avoided, could result in death or serious injury.

CAUTION



Caution!

This safety note points out a potentially dangerous situation which, if not avoided, can result in minor or slight injuries.

NOTICE

This safety note points out a potentially dangerous situation which, if not avoided, can cause substantial damage to property and the environment.



This note contains important additional information as well as useful tips for safe, efficient and trouble-free operation of the module.

Further warning signs:

Where applicable, the following standardised symbols are used in this manual to point out the various potential health risks.

	Warning - Dangerous electrical voltage.
	Warning - Risk of injury from contact with hot surfaces.
	Warning - Risk of hand and finger injury due to uncontrolled movements of components.
	Warning - Magnetic field.
	Warning - back injury due to heavy lifting.
	Warning - Risk of injury as a result of parts being flung out!
	Warning - high noise levels.

1.3 Additional symbols

In these assembly instructions the following symbols are used to highlight instructions, results, references, etc.

Symbol	Description
1.	Instructions (steps ...)
⇒	Results of actions
↻	References to sections
■	Enumerations not ordered

1.4 Applicable documents

In addition to the assembly instructions, the following documents must be observed:

- Safety data sheets etc.
- Instructions for integrated components ( supplier documentation)



Each rotary module is accompanied by a safety information sheet. This information sheet must be read carefully by every person who carries out work on and with the rotary module.

1.5 Warranty

The warranty terms for Afag handling components and handling systems are the following:

- 24 months from initial operation and up to a maximum of 27 months from delivery.
- Wear parts (e.g. shock absorbers) are excluded from the warranty.*

The warranty covers the replacement or repair of defective Afag parts. Further claims are excluded.

* *However, a customer has a right to a defect-free product. This does also apply to defective accessories and wear parts. Normal wear and tear is excluded from the warranty.*

The warranty shall expire in the following cases:

- Improper use of the module
- Non-observance of the instructions regarding assembly, commissioning, operation and maintenance of the module
- Improper assembly, commissioning, operation and maintenance
- Repairs and design changes carried out without prior technical instructions of Afag Automation AG
- Removing the serial number from the product
- Using the module without shock absorbers or with defective shock absorbers
- Inadequate checking of wear parts
- Non-observance of the EC Machinery Directive, the Accident Prevention Regulations, the Standards of the German Electrotechnology Association (VDE) and these safety and assembly instructions

1.6 Liability

No changes shall be made to the rotary modules CR 12, CR 16, CR 20 unless described in this instructions manual or approved in writing by Afag Automation AG.

Afag Automation AG accepts no liability for unauthorized changes or improper assembly, installation, commissioning, operation, maintenance or repair work.

2 Safety instructions

2.1 General

This chapter provides an overview of all important safety aspects to ensure safe and proper use of the rotary module and optimal protection of personnel.



Failure to follow the directions and safety instructions given in this instructions manual may result in serious hazards.

2.2 Intended use

The CR 12, CR 16, CR 20 rotary modules are used for shock-free gripping/rotating of loads in non-hazardous atmospheres under the ambient and operating conditions defined for these modules.

The rotary modules are designed exclusively for gripping payloads that do not pose any danger to persons, property or the environment during manipulation. In combination with other modules the rotary modules can be used as a pick & place Station.



In the chemical industry and in potentially explosive areas, the use of rotary modules is not permitted without additional safety measures. In such cases, please consult with the Afag technical department.

The intended use of the module also includes:



- observance of all instructions given in this instructions manual,
 - compliance with the inspection and maintenance work and the specifications in the data sheets,
 - using only original spare parts.
-

2.3 Foreseeable misuse

Any use other than or beyond the intended use described above is considered a misuse of the rotary module.

Especially the following use is considered a misuse:

- Use in potentially explosive atmospheres

WARNING



Risk of injury if the module is not used as intended!

The improper use of the rotary modules poses a potential hazard to the personnel.

- The rotary module may only be used in a technically perfect condition in accordance with its intended use and the instructions in this manual and in compliance with the safety requirements!
- Any malfunctions, particularly those that could impair safety, must be eliminated immediately!



Risks can occur if the module is not used as intended. In the event of damages caused by improper use the following shall apply:

- the operating company shall be solely responsible for such damage, and
- Afag does not accept any liability for damages caused by improper use.

2.4 Obligations of the operator and the personnel

2.4.1 Observe the assembly instructions

A basic prerequisite for safe and proper handling of the rotary modules is a good knowledge of the basic safety instructions.



These assembly instructions, in particular the safety instructions contained therein, must be observed by all persons working with the rotary modules.

2.4.2 Obligations of the operating company

In addition to the safety instructions given in this manual, the operating company must comply with the safety, accident prevention and environmental protection regulations valid for the field of application of the rotary modules.

The operating company is required to use only personnel who:

- have the necessary professional qualifications and experience,
- are familiar with the basic rules regarding occupational safety and accident prevention,
- have been instructed in the correct handling of the rotary modules,
- have read and understood these assembly instructions.

The operating company is also required to:

- monitor on an ongoing basis that the personnel work safely considering any potential hazard involved and the assembly instructions are observed,
- ensure that the assembly instructions are always kept at hand at the installation in which the modules are mounted,
- observe and communicate universally applicable laws and regulations regarding accident prevention and environmental protection,
- provide the necessary personal protective equipment (e.g. protective gloves) and instruct the personnel to wear it and
- update the related safety data sheets.

2.4.3 Obligations of the personnel

All personnel working with the rotary modules are required to:

- read and observe these assembly instructions, especially the chapter on safety,
- observe the occupational safety and accident prevention regulations,
- observe all safety and warning signs on the rotary modules,
- refrain from any activity that might compromise safety and health.



In addition, the personnel must wear the personal protective equipment required for carrying out their work. (👉Chapter 0).

2.5 Personnel requirements

2.5.1 Personnel qualification

The activities described in the assembly instructions require specific requisites at the level of professional qualifications of the personnel.

Personnel not having the required qualification will not be able to assess the risks that may arise from the use of the rotary modules thus exposing himself and others to the risk of serious injury. Therefore, only qualified personnel may be permitted to carry out the described activities on the rotary modules.

Persons whose ability to react is restricted due to the intake of medication or the like must not interact with the rotary modules.

These installation instructions are intended for skilled personnel (installers, system integrators, maintenance personnel, technicians), electricians and operating personnel.

The following is a description of the professional skills (qualifications) required for carrying out the different activities:

Qualified personnel:

Qualified personnel with appropriate training who are qualified due to their special know-how and fully familiar with the machine and who have been given instructions on how to carry out the task entrusted to them safely.

Qualified electrician:

Persons who have obtained their electrical qualifications through appropriate professional training and complementary courses that enables them to identify risks and prevent possible hazards resulting from electricity.

Operator (trained personnel):

Authorized persons who due to their specialized professional training, expertise and experience are capable of identifying risks and preventing possible hazards arising from the use of the machine.





2.6 Personal protective equipment (PPE)

The personal protective equipment serves to protect the personnel from hazards affecting their safety and health at work.

When working on/with the rotary modules, the personnel must wear the personal protective equipment assigned by the safety officer of the operating company or as required by safety regulations. In addition, the personnel is required to:

- wear the personal protective equipment provided by the operating company (employer),
- check the personal protective equipment for proper condition, and
- immediately notify the person responsible on site of any defects found on the personal protective equipment.

Personal protective equipment and the respective mandatory signs:

	<p><i>Protective clothing</i> is a close-fitting clothing specifically designed to protect personnel from hazards during work.</p>
	<p><i>Protective gloves</i> are specifically designed to protect the personnel against hand injuries (such as cuts, abrasion, burns).</p>
	<p><i>Safety shoes</i> are specifically designed to protect the personnel against foot injuries from crushing, falling objects or slipping on slippery surfaces.</p>
	<p>Hearing <i>protectors</i> are required to protect the personnel against excessive noise levels to prevent noise-induced hearing loss.</p>

2.7 Changes and modifications

No changes may be made to the rotary modules which have not been described in these assembly instructions or approved in writing by Afag Automation AG.

Afag Automation AG accepts no liability for unauthorised changes or improper assembly, installation, commissioning, maintenance or repair work.



The rotary modules may not be changed or modified in any way, except with the prior written consent of Afag Automation AG.

2.8 General hazards / Residual Risks

Despite the safe design of the machine and the technical protective measures taken, there still remain residual risks that cannot be avoided, and which present a non-obvious residual risk when operating the rotary modules.

Observe the safety instructions in this chapter and in the other sections of this manual to avoid damage to property and dangerous situations for the personnel,

2.8.1 General hazards at the workplace

The rotary module has been built according to the state-of-the-art and the applicable health and safety requirements. However, improper use of the rotary modules may cause the following hazards to the personnel:

- danger to life and limb of the operator or third parties,
- on the rotation modules themselves,
- Property damage.



Always keep the assembly instructions ready at hand at the workplace! Please, also observe:

- the general and local regulations on accident prevention and environmental protection.
- the safety information sheet for the rotary modules.



WARNING

Danger - Do not use in unsuitable environment!

The rotary modules are designed for use in **non** explosive atmospheres.

- Do **not** use the rotary modules in potentially explosive atmospheres!



CAUTION

Danger of injury in the working area of the rotary modules!

Due to the decentralised control system, the operator of the rotary modules must not necessarily stand next to the rotary modules during operation so that he may not have a complete view of the working area. Persons in the working area may be injured.

- When operating the rotary modules, ensure a good overview of the entire working area.
- Unauthorized persons must not stay within the working area during operation.

CAUTION



Risk of injuries due to uncontrolled parts movements!

When operating the rotary modules uncontrolled movements may occur which can cause personal injury or property damage.

- Only qualified personnel may work with or on the rotary modules.
- Read the assembly instructions carefully before carrying out any work on or with the rotary modules.

CAUTION



Risk of noise-induced hearing loss!

When the rotary modules are installed in a machine or plant, the permissible noise level may be exceeded depending on the various components, the environment and the resonance.

- The operating company is responsible for ensuring that the permissible noise levels are observed.
- If the noise level exceeds 85 dB(A) in normal operation, the operator must wear hearing protectors at the workplace.

2.8.2 Danger due to electricity

WARNING



Danger! Risk of electric shock!

If work on electrical components is required, ensure that the work is carried out properly, failure to do so will cause serious or fatal injuries.

- Work on the machine's electrical equipment may only be performed by skilled electrician or trained personnel under the supervision of a skilled electrician in accordance with all relevant electrical regulations.

2.8.3 Mechanical hazards

CAUTION



Danger of injury by moving components!

Limbs can be crushed by moving components!

- Work on and with the rotary modules may only be carried out by qualified personnel.

WARNING



Risk of injury - Do not reach into the system during operation!

There is a risk of injury if the personnel reach into the system during normal operation.

- Never reach into the system during normal operation!

2.8.4 Danger due to pneumatics

WARNING



Risks by the pneumatic system!

The pneumatic system can pose various hazards that can cause serious or fatal injuries if the work is carried out improperly.

- Only qualified personnel may work with or on the pneumatic system!
 - The necessary personal protective equipment must be provided and used.
-

2.8.5 Danger caused by omitting maintenance work

CAUTION



Danger of injury!

Poor or not regularly performed maintenance work may cause malfunction of the components which may result in injuries.

- The due diligence obligations of the operating company include ensuring that the personnel carrying out maintenance work is appropriately trained and qualified.
-

3 Technical data

3.1 Rotary module CR 12

3.1.1 Dimensional drawing CR 12

Type	CR 12	CR 12 - ZA
A	Bore fitting	Bore fitting
P	M5	M5
P1	Clockwise	Clockwise
P2	Counterclockwise	Counterclockwise

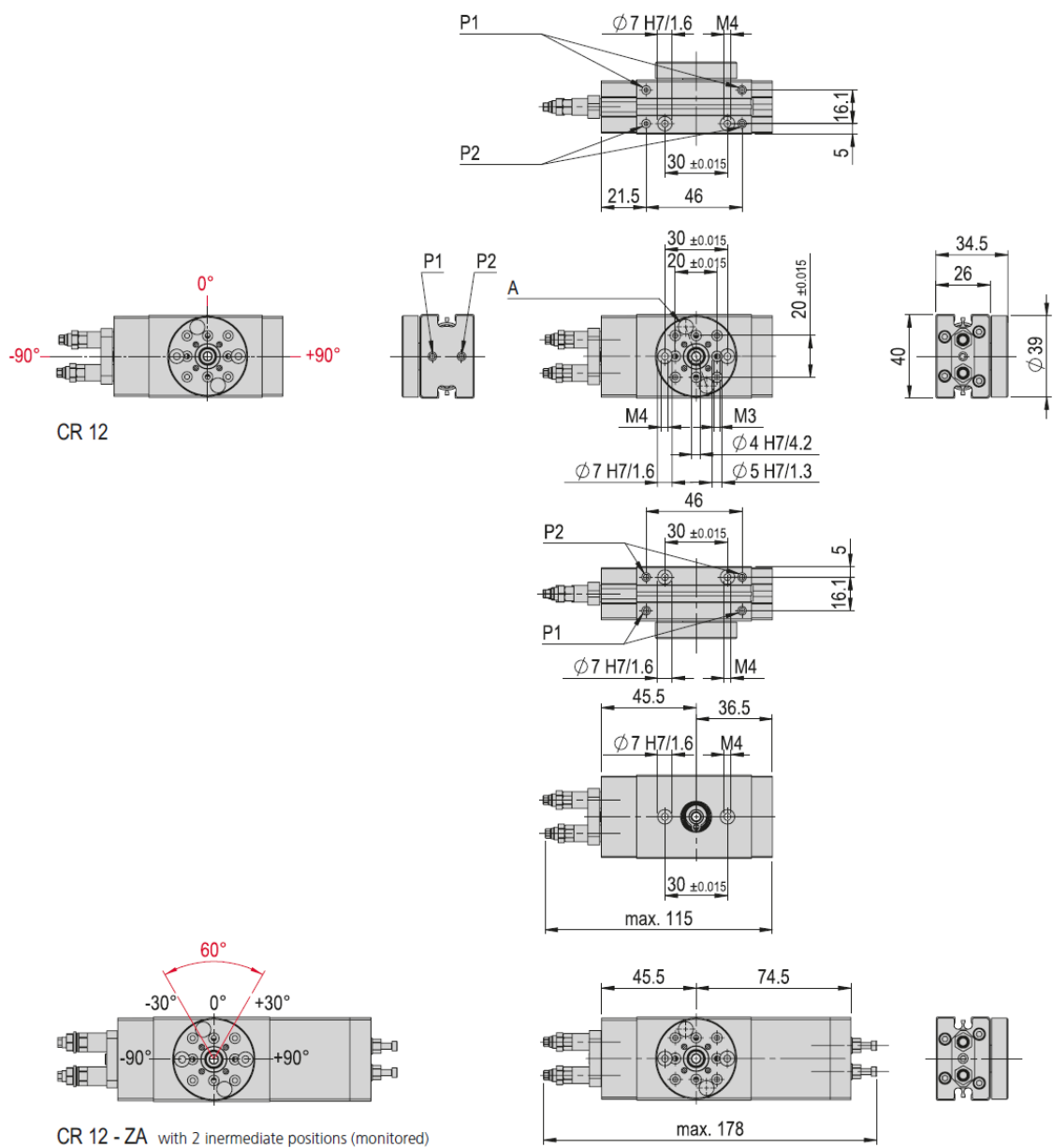



The flange hole patterns shown are in the 0° position for all modules. The flange rotates 95° to the left and 95° to the right.

Fig. 1 Dimensional drawing - Rotary module CR 12

Technical data

3.1.2 Technical data CR 12

CR 12		
Attachment grid	48 mm	
Attachment grid alternative	30 mm	
Attachment thread	M6	
Attachment thread alternative	M4	
Operating pressure	6 +/- 2 bar	
Air connection P	M5	
Operating temperature	0 - 50 °C	
Storage temperature	0 - 50 °C	
Humidity	< 90 %	
Medium filtered compressed air	10 - 40 µm	

Type	CR 12	CR 12 - ZA
Order number	50112939	50112940
Net weight	0.324 kg	0.42 kg
Air consumption (180°)	0.0009 NL	0.0009 NL
Angle of rotation	0-180 °	0-180 °
Min. rotation time 180°	0.15 s	0.15 s
Noise level	54 dB (A)	54 dB (A)
Angle accuracy	+/- 0.06 °	+/- 0.06 °
Torque	0.45 Nm	0.45 Nm
Max. moment of inertia	*10 kgcm ²	*10 kgcm ²
Positions	2	4
Mounting position		

The technical data refer to a nominal pressure of 6 bar under Afag standard test conditions.

Note: If a turning force acts against the direction of rotation in the end position, a drive with twice the theoretical torque should be selected.
The module can be operated with lubricated or dry air. It is possible to switch from dry to lubricated but not vice versa.
Cleanroom class ISO 14644-1, class ISO 7

*Observe rotation time diagram

Included in the delivery (Catalogue HT accessories)

- 2x Centering bushing Ø7x3
- 2x Special screw M4 x 30/8.5
- 2x Shock absorber SD M6x0.5 -2

Accessories

- (Catalogue HT accessories)
- INI c10x28.5-Em-PNP-NO-M8x1

Fig. 2 Table technical data CR 12

* In the end position, only half the torque is achieved, since in this position the pressure is exerted by one piston only (↪chapter **Fehler! Verweisquelle konnte nicht gefunden werden.**).

3.1.1 Preferred combinations CR 12

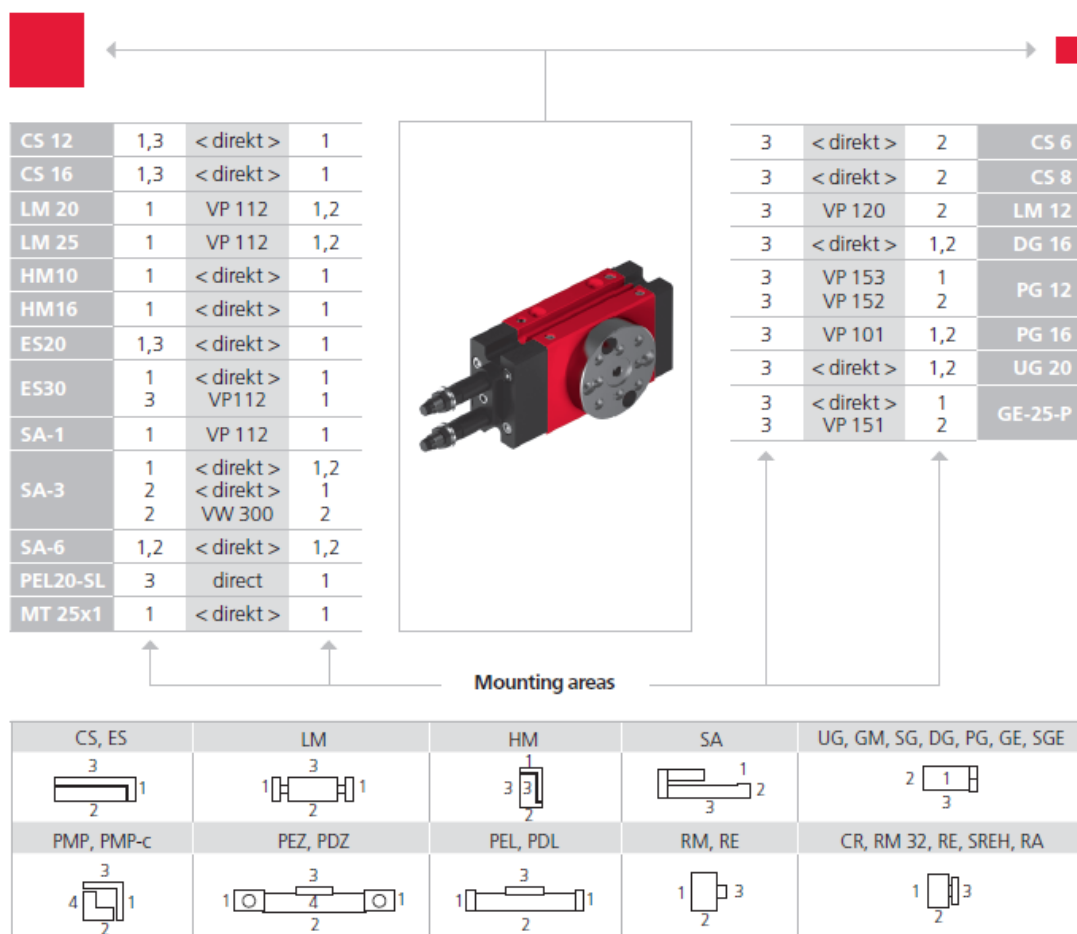

Note that there might be different mounting positions from one module to another one.

The required connection elements and the range of support columns are depicted in the catalogue HT accessories.

3.1.2 Module loads CR 12

Type	CR 12	CR 12 - ZA
Max. force, axial pushing static	200 N	200 N
Max. force, axial pulling static	100 N	100 N
Max. force, axial pushing dynamic	80 N	80 N
Max. force, axial pulling dynamic	40 N	40 N
Max. payload, radial dynamic	130 N	130 N
Max. payload, radial static	340 N	340 N

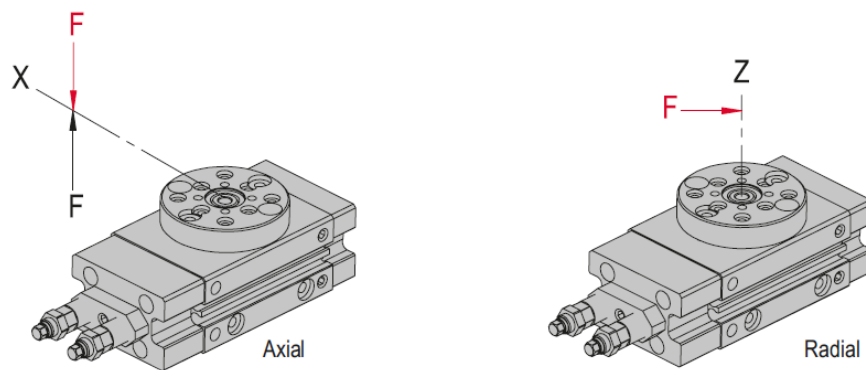
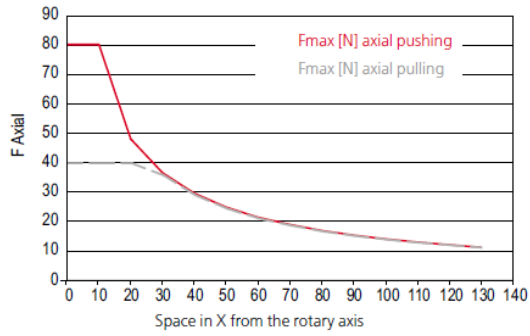

Fig. 3 Table module loads CR 12

3.1.3 Load diagrams CR 12

Load diagrams

Axial dynamic



Axial dynamic

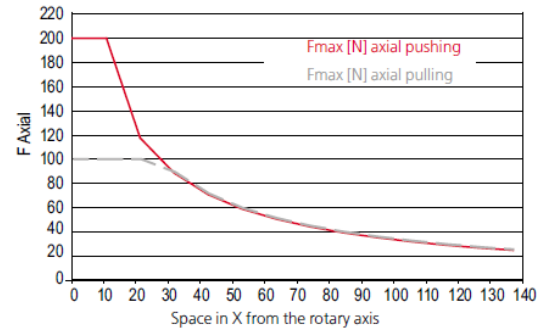

Axial dynamic

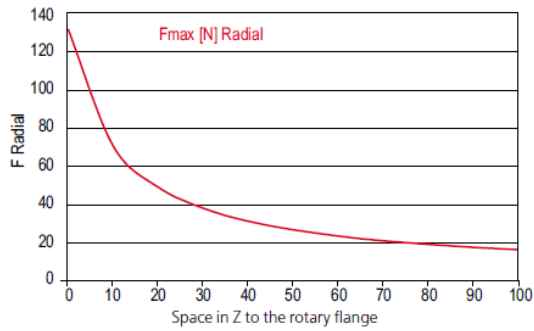

Axial dynamic

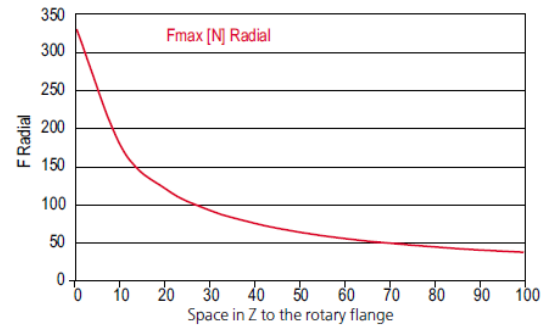

Axial dynamic

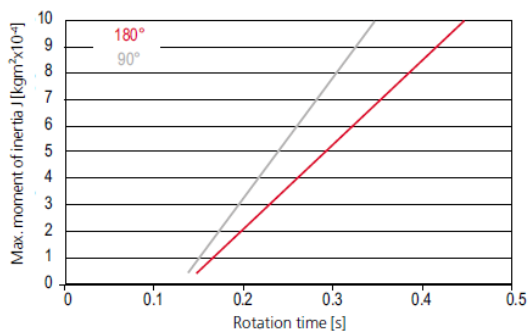
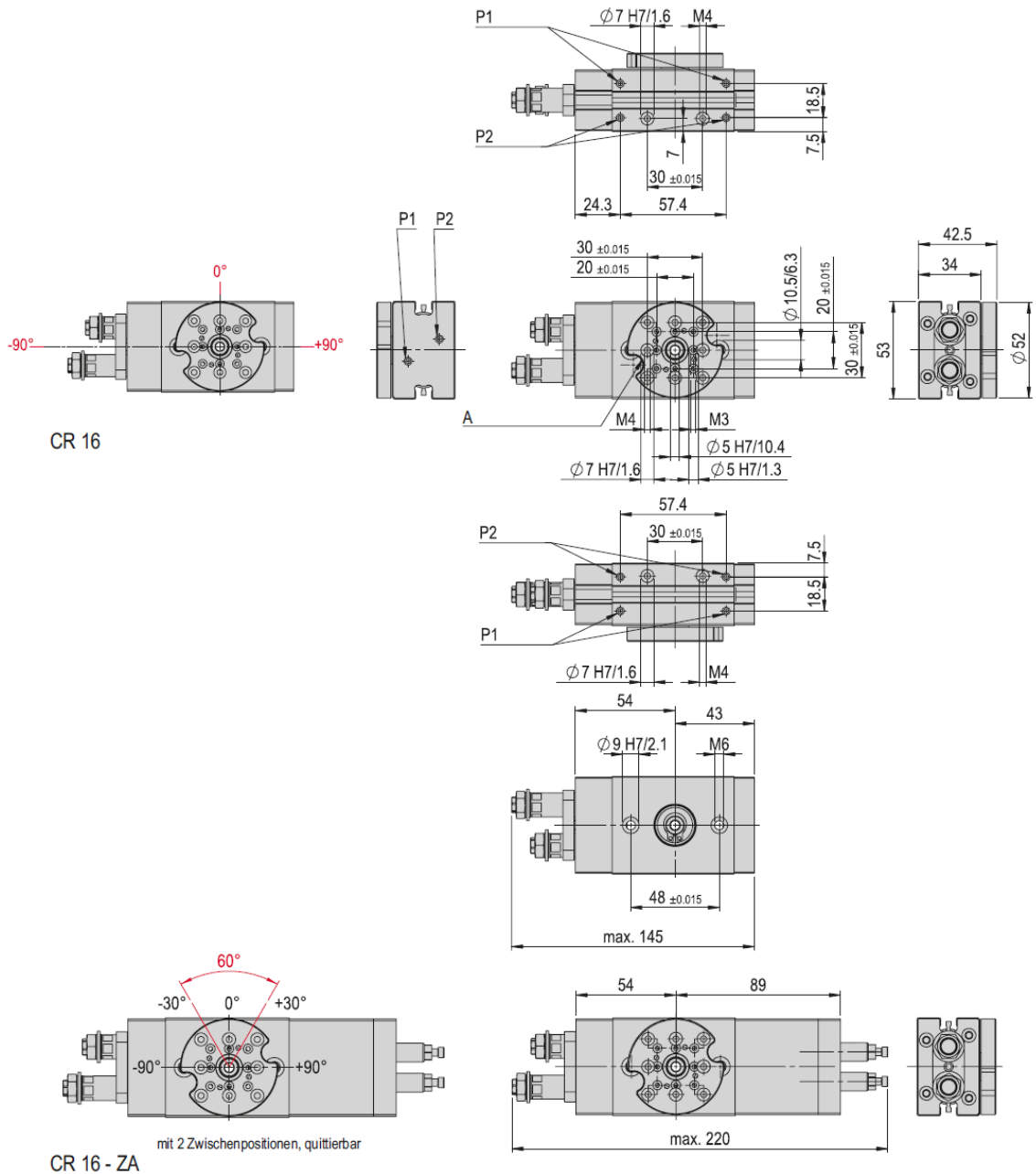

Fig. 4 Load diagrams CR 12

3.2 Rotary module CR 16

3.2.1 Dimensional drawing CR 16

Type	CR 16	CR 16 - ZA
A	Bore fitting	Bore fitting
P	M5	M5
P1	Clockwise	Clockwise
P2	Anti-clockwise	Anti-clockwise





The flange hole patterns shown are in the 0° position for all modules. The flange rotates 95° to the left and 95° to the right.

Fig. 5 Dimensional drawing - Rotary module CR 16

3.2.2 Technical data CR 16

CR 16	
Attachment grid	48 mm
Attachment grid alternative	30 mm
Attachment thread	M6
Attachment thread alternative	M4
Operating pressure	6 +/- 2 bar
Air connection P	M5
Operating temperature	0 - 50 °C
Storage temperature	0 - 50 °C
Humidity	< 90 %
Medium filtered compressed air	10 - 40 µm

Type	CR 16	CR 16 - ZA
Order number	50112941	50112942
Net weight	0.69 kg	0.9 kg
Air consumption (180°)	0.0018 NL	0.0018 NL
Angle of rotation	0-180 °	0-180 °
Min. rotation time 180°	0.27 s	0.27 s
Noise level	54 dB (A)	54 dB (A)
Angle accuracy	+/- 0.05 °	+/- 0.05 °
Torque	1.25 Nm	1.25 Nm
Max. moment of inertia	*70 kgcm ²	*70 kgcm ²
Positions	2	4
Mounting position		

The technical data refer to a nominal pressure of 6 bar under Afag standard test conditions.

Note: If a turning force acts against the direction of rotation in the end position, a drive with twice the theoretical torque should be selected.

The module can be operated with lubricated or dry air. It is possible to switch from dry to lubricated but not vice versa.

Cleanroom class ISO 14644-1, class ISO 7

* Observe swivel time diagram

Included in the delivery
 (Catalogue HT accessories)

- 2x Centering bushing Ø7x3
- 2x Centering bushing Ø9x4
- 2x Special screw M6 x 3/8
- 2x Shock absorber SD M10x1 -4

Accessories

(Catalogue HT accessories)

- INI c10x28.5-Em-PNP-NO-M8x1

Fig. 6 Table technical data CR 16

* In the end position, only half the torque is achieved, since in this position the pressure is exerted by one piston only).

Technical data

3.2.3 Preferred combinations CR 16

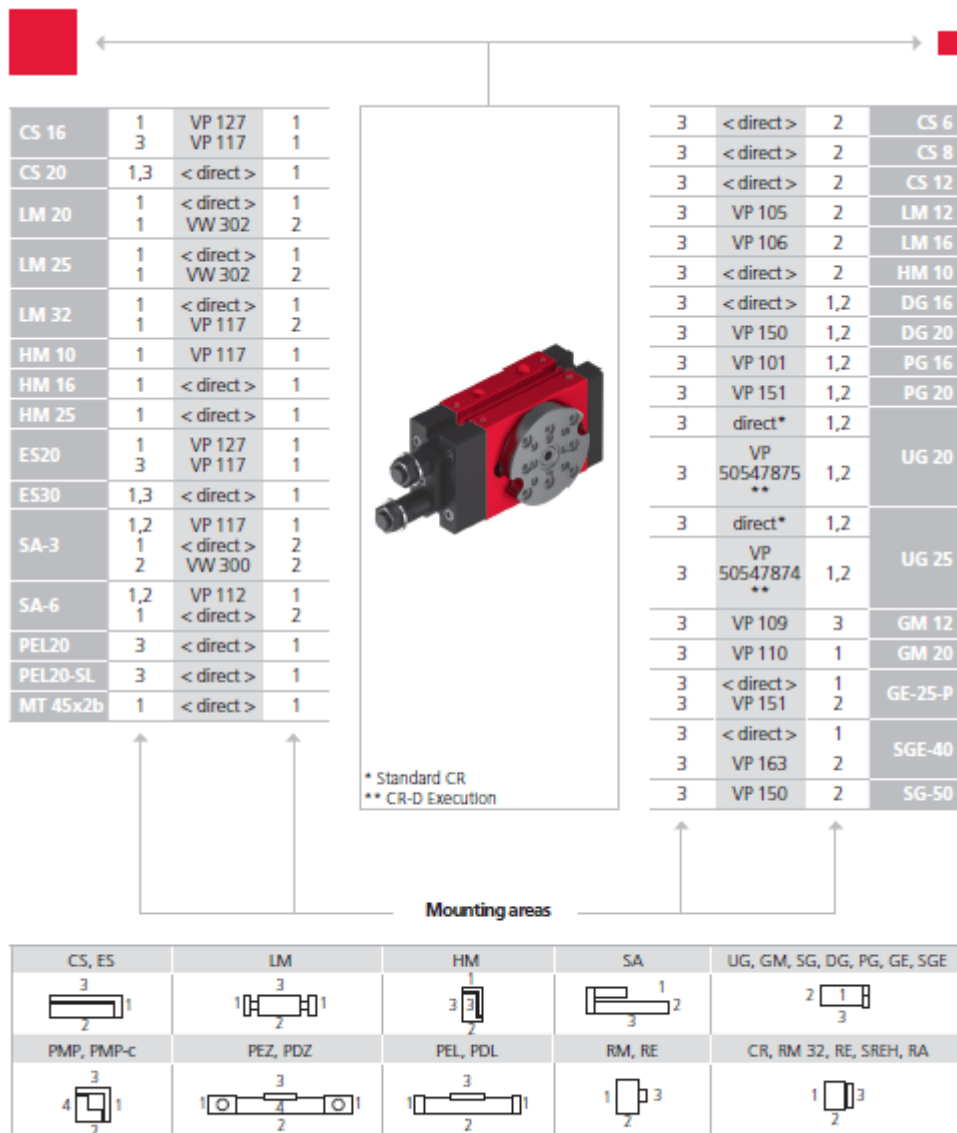

Note that there might be different mounting positions from one module to another one.

The required connection elements and the range of support columns are depicted in the catalogue HT accessories.

3.2.4 Module loads CR 16

Type	CR 16	CR 16 - ZA
Max. force, axial pushing (static)	500 N	500 N
Max. force, axial pulling (static)	220 N	220 N
Max. force, axial pushing (dynamic)	200 N	200 N
Max. force, axial pulling (dynamic)	100 N	100 N
Max. payload, radial dynamic	350 N	350 N
Max. payload, radial static	800 N	800 N

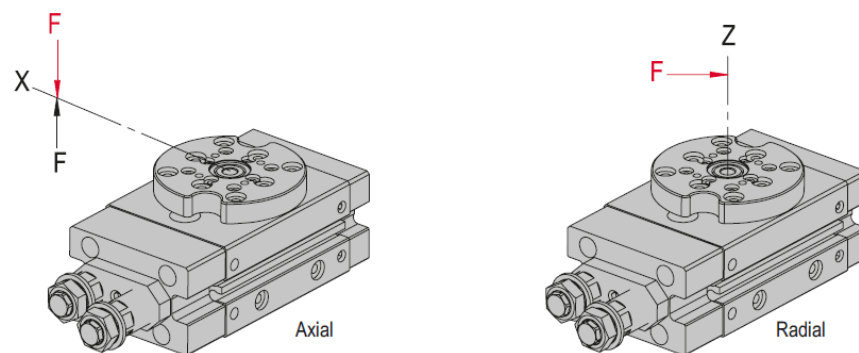

Fig. 7 Table module loads CR 16

3.2.5 Load diagrams CR 16

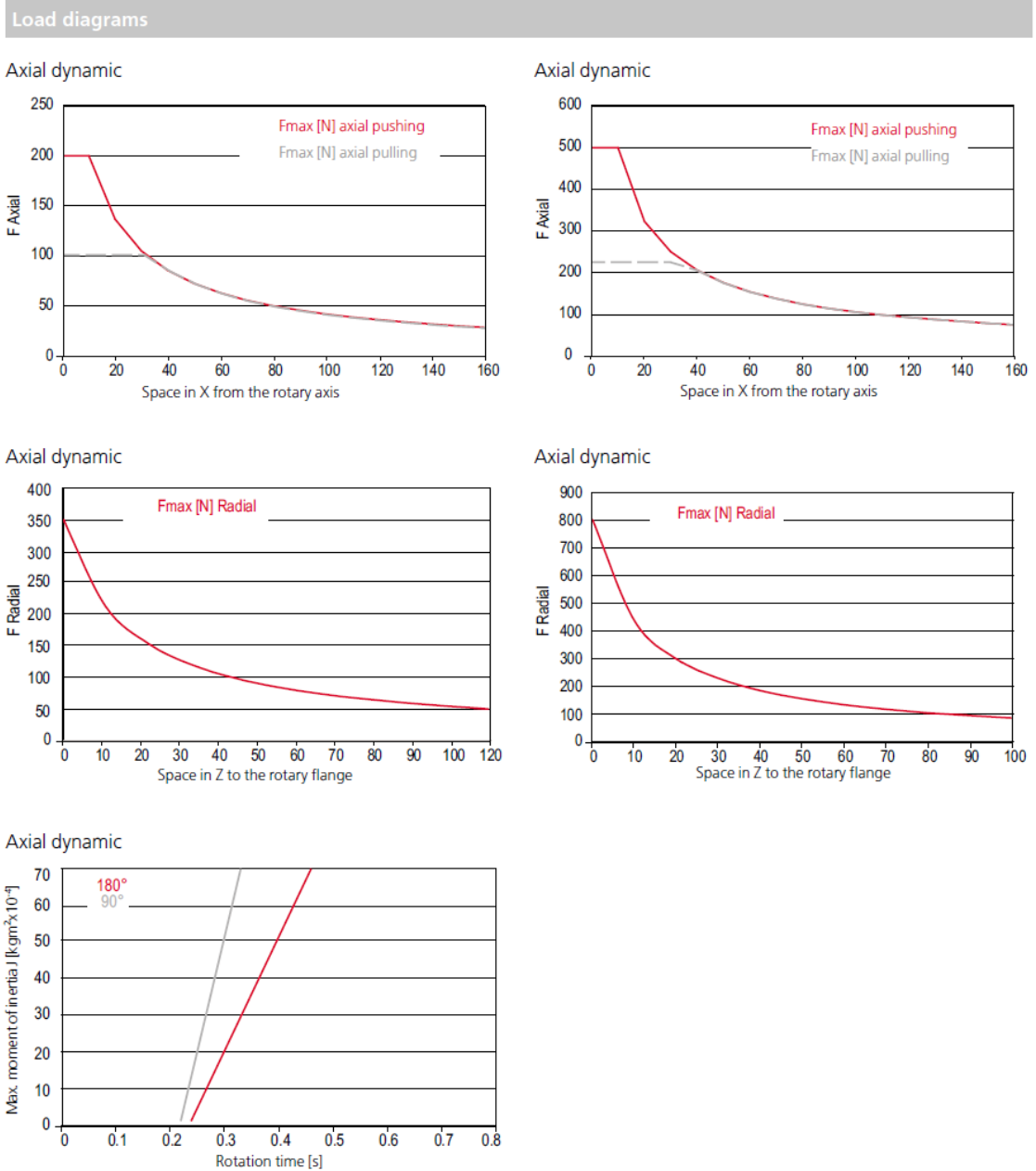

Fig. 8 Load diagrams CR 16

3.3 Rotary module CR 20

3.3.1 Dimensional drawing CR 20

Type	CR 20	CR 20 - ZA
A	Bore fitting	Bore fitting
P	M5	M5
P1	Clockwise	Clockwise
P2	Anti-clockwise	Anti-clockwise

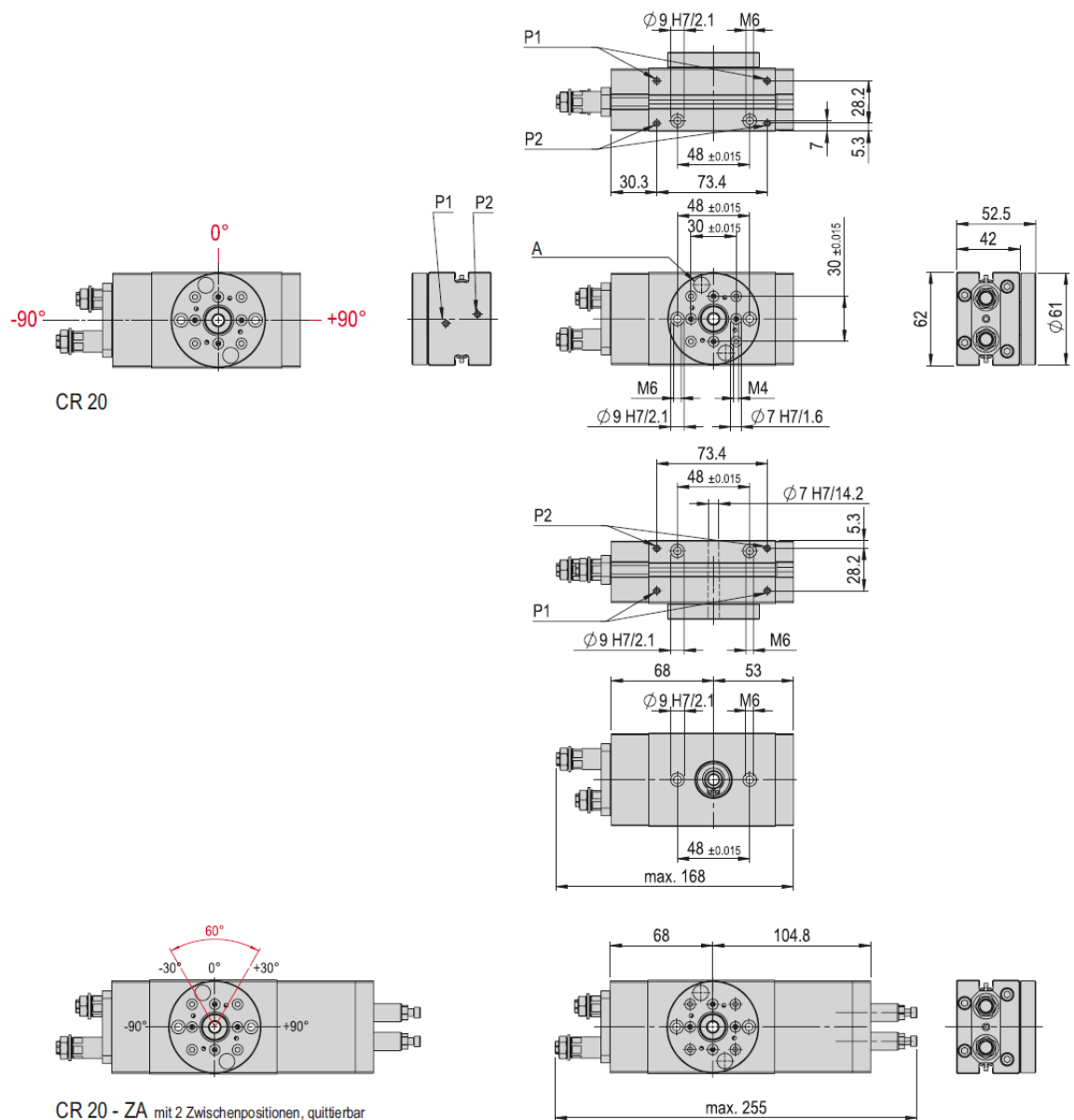



Fig. 9 Dimensional drawing - Rotary module CR 20

3.3.2 Technical data CR 20

CR 20	
Attachment grid	48 mm
Attachment thread	M6
Operating pressure	6 +/- 2 bar
Air connection P	M5
Operating temperature	0 - 50 °C
Storage temperature	0 - 50 °C
Humidity	< 90 %
Medium filtered compressed air	10 - 40 µm

Type	CR 20	CR 20 - ZA
Order number	50112943	50112945
Net weight	1.28 kg	1.6 kg
Air consumption (180°)	0.003 NL	0.003 NL
Angle of rotation	0-180 °	0-180 °
Min. rotation time 180°	0.35 s	0.35 s
Noise level	54 dB (A)	54 dB (A)
Angle accuracy	+/- 0.05 °	+/- 0.05 °
Torque	2.2 Nm	2.2 Nm
Max. moment of inertia	*350 kgcm ²	*350 kgcm ²
Positions	2	4
Mounting position		

The technical data refer to a nominal pressure of 6 bar under Afag standard test conditions.

Note: If a turning force acts against the direction of rotation in the end position, a drive with twice the theoretical torque should be selected. The module can be operated with lubricated or dry air. It is possible to switch from dry to lubricated but not vice versa. Cleanroom class ISO 14644-1, class ISO 7

* Observe swivel time diagram

Included in the delivery
(Catalogue HT accessories)

- 2x Centering bushing Ø7x3
- 2x Centering bushing Ø9x4
- 2x Special screw M6 x 36/8
- 2x Shock absorber SD M10x1 -4
- 4x O-ring 2.5x0.62 mm
- 2x Set screw M5x4

Accessories

(Catalogue HT accessories)

- INI c10x28.5-Em-PNP-NO-M8x1

Fig. 10 Table technical data CR 20

* In the end position, only half the torque is achieved, since in this position the pressure is exerted by one piston only).

3.3.3 Preferred combinations CR 20

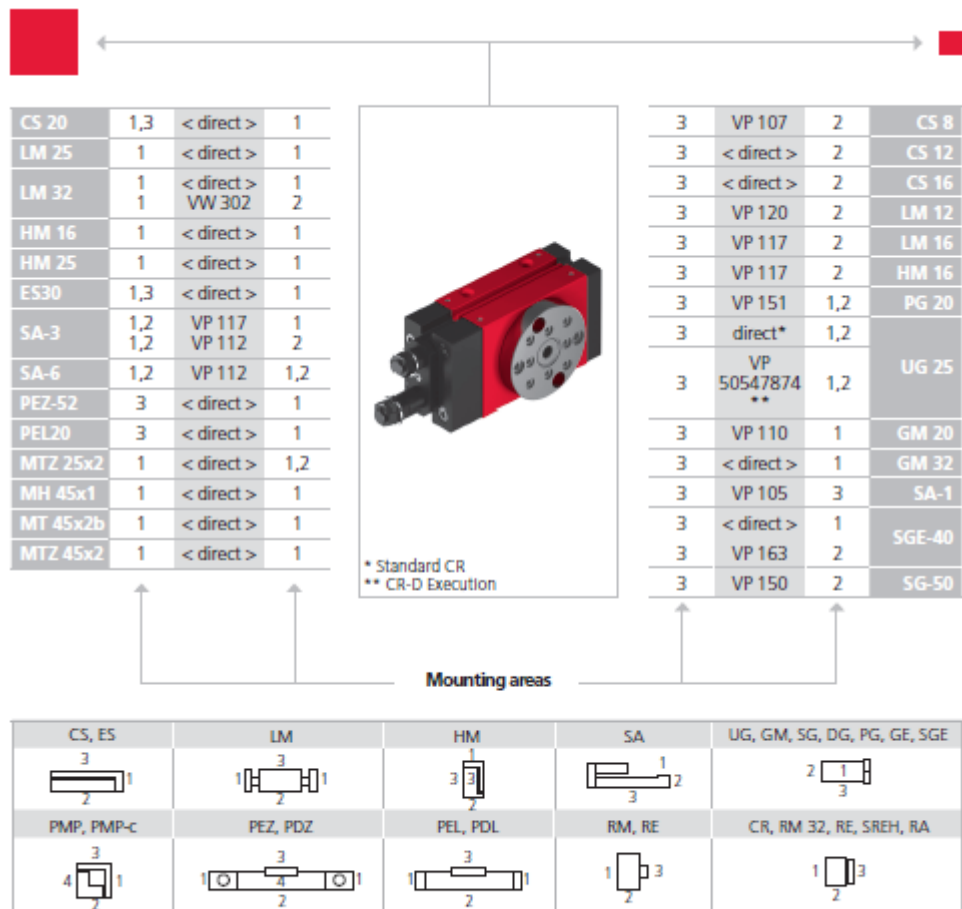

Note that there might be different mounting positions from one module to another one.

The required connection elements and the range of support columns are depicted in the catalogue HT accessories.

3.3.4 Module loads CR 20

Type	CR 20	CR 20 - ZA
Max. force, axial pushing (static)	900 N	900 N
Max. force, axial pulling (static)	250 N	250 N
Max. force, axial pushing (dynamic)	250 N	250 N
Max. force, axial pulling (dynamic)	120 N	120 N
Max. payload, radial dynamic	400 N	400 N
Max. payload, radial static	1000 N	1000 N

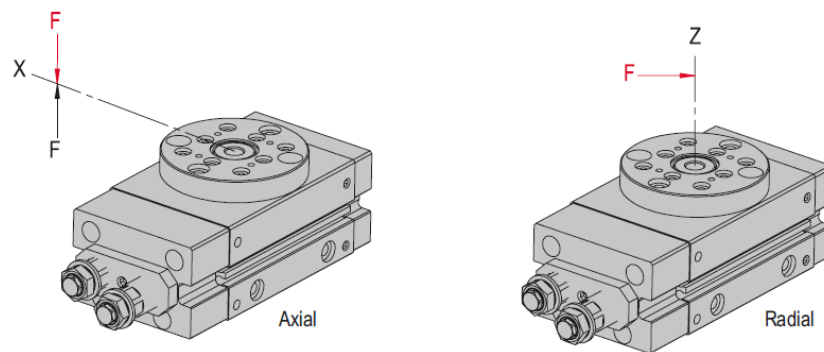

Fig. 11 Table module stresses CR 20

3.3.5 Load diagrams CR 20

Load diagrams

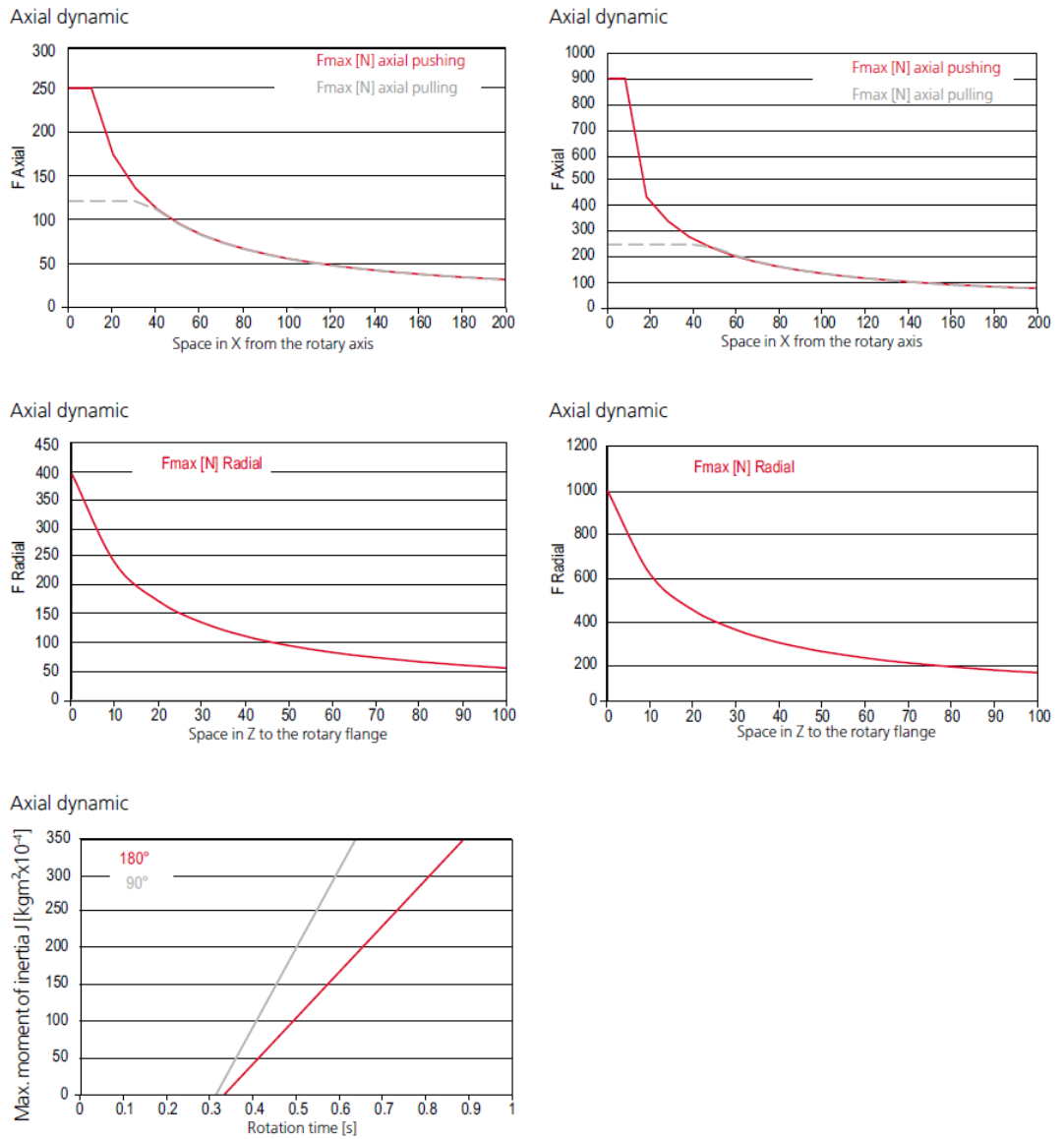

Fig. 12 Load diagrams CR 20

4 Transport, Packaging and Storage

This chapter provides information regarding proper transport, packaging and storage of the rotary modules.

4.1 Safety instructions for transport

CAUTION



Danger of injury when unpacking the rotary modules!

The rotary modules are packed in the original packaging (cardboard box). If handled incorrectly, the module may fall out of the box when unpacked and cause limb injuries.

- Carefully unpack the rotary modules.



Also observe the safety instructions in  chap. 2 „Safety instructions“ in this manual.

4.2 Scope of supply

The rotary modules are supplied with an operating and assembly manual and a safety data sheet (see scope of supply below).



Fig. 13 Scope of delivery rotary modules CR 12 / CR 16 / CR 20

[Unt]	CR 12	[Unt]	CR 16, CR 20
2 x	Centering bushing Ø7x3 mm	2 x	Centering bushing Ø7x3 mm
2 x	Special screw M6x30/8.5 mm	2 x	Centering bushing Ø9x4 mm
2 x	Shock absorber SD M6x0.5-2	2 x	Special screw M6x36/8 mm
		2 x	Shock absorber SD M10x1-4

4.3 Transport



No liability can be assumed for damages caused by improper installation on the part of the operating company.







The following conditions must be complied with for transport and storage:

- Storage temperature: 0-50 °C
- Relative air humidity: < 90%, non condensing

4.4 Packaging

The rotary modules are packed in the most appropriate manner.

Standardized symbols for packages

Symbol	Note	Explanation
	Top	The package shall be transported, handled and stored with the arrows always pointing upwards (top side of the package).
	Fragile	Products marked with this symbol shall be handled with care and may never be turned upside down or tied up.
	Protect against moisture	The packages shall be protected against moisture and kept dry (keep covered during storage).
	Attachment points	The hosting equipment (chain, etc.) may only be attached to the points marked by this symbol.
	Centre of gravity	This symbol marks the centre of gravity of the packages (pay attention to the position of the centre of gravity).

NOTICE

Risk to the environment due to incorrect disposal of the packaging material!

Environmental damage can be caused by incorrect disposal of the packaging material.

- Dispose of the packaging material in an environmentally sensitive way in accordance with the local environmental regulations.

4.5 Storage

If the rotary modules are stored for an extended period, observe the following:

- Do not store the rotary modules outdoors or expose them to weather conditions.
- The storage space must be dry and dust free.
- Room temperature of the storage space: 0-50 °C.
- Relative air humidity: < 90% non condensing
- Clean the rotary modules and protect the blank metal parts against corrosion using the appropriate means.
- Protect the rotary modules from dirt and dust.

5 Structure and description

This chapter provides an overview of the rotary modules' structure and functioning.

5.1 Construction rotary modules

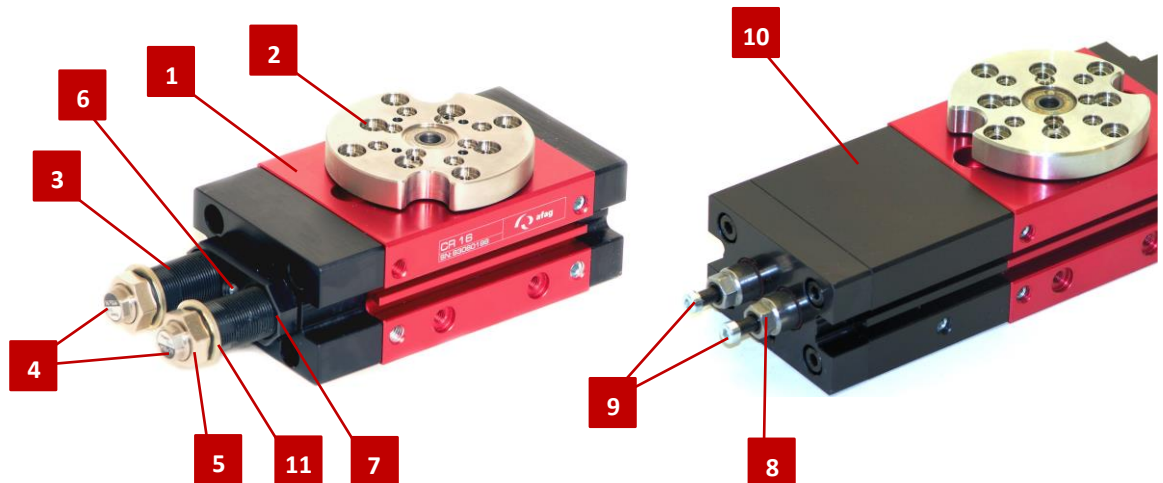

Fig. 14 Structure of the rotary module CR

- | | |
|--------------------------------|--|
| 1. Housing | 7. Clamping plate |
| 2. Flange | 8. Lock nut for positioning pin |
| 3. Stop sleeve AS | 9. Positioning pins Intermediate stop ZA |
| 4. Shock absorber SD | 10. Housing for intermediate stop |
| 5. Lock nut for shock absorber | 11. Seal for shock absorber |
| 6. Clamping screw | |

5.2 Product description

Rotary modules of the CR 12 / CR 16 / CR 20 series are precision devices. In order to ensure safe and reliable operation it is important that the modules are handled with care.

The rotary modules are highly compact, pneumatic modules and are used for the shock-free rotation of permanently mounted loads in the defined ambient and operating conditions.

The assembly position of the rotary modules can be vertical or horizontal.

Structure and description

5.3 Accessories

5.3.1 Accessories CR 12, CR 16, CR 20

Initiator - INI c10x28.5-Em-PNP-NO-M8x1	
Order Number	50033432
Net weight	0.02 kg
Operating voltage	10 – 30 VDC

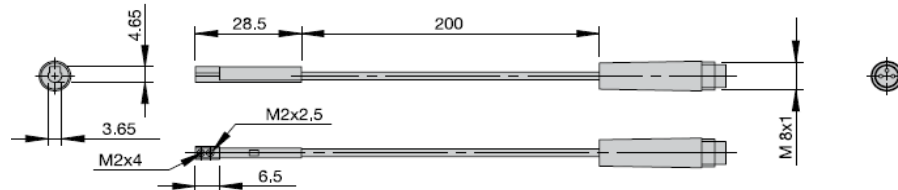

5.3.2 Other accessories CR 12, CR 16, CR 20

Shock absorber SD M 6x0.5-2	
Order Number	50310020
Stroke H	4 mm
Net weight	0.007 kg
Max. Energy consumpt./stroke	1.5 Nm
Max. Energy consumption/h	3 200 Nm
Suitable for	CR 12

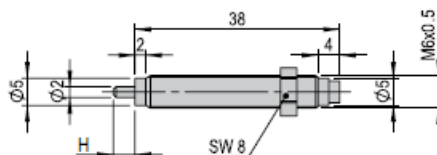

Seal for SD M6x0.5-2	
Order Number	50310021
Net weight	0.001 kg
Suitable for	SD M6x0.5-2

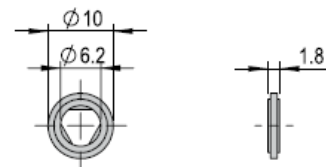

Shock absorber SD M 10x1-4	
Order Number	50279077
Stroke H	8 mm
Net weight	0.038 kg
Max. Energy consumpt./stroke	12 Nm
Max. Energy consumption/h	20,000 Nm
Suitable for	CR 16, CR 20

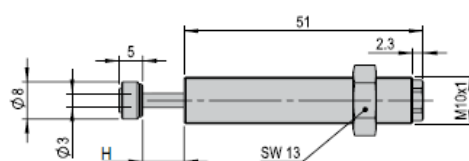

Seal for SD M10x1-4	
Order Number	50300442
Net weight	0.002 kg
Suitable for	SD M10x1-4

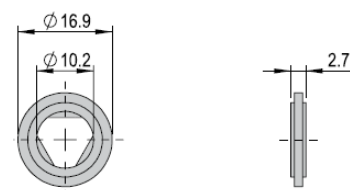

You will find more information on the accessories for the rotary modules on our website www.afag.com.

5.4 Fields of application

The CR rotary modules are exclusively designed for rotational movements for the following payloads (➔chapter 3):

- CR 12: 10 kg/cm²
- CR 16: 70 kg/cm²
- CR 20: 350 kg/cm²



In combination with other modules the rotary modules can be used as a pick & place Station.

However, the permissible payloads must not be exceeded.

Note regarding the torque:

The specified torque depends on the piston position. If a piston is in its end position, only half the torque is achieved. In this case the pressure is only exerted by the piston which is not in its end position.

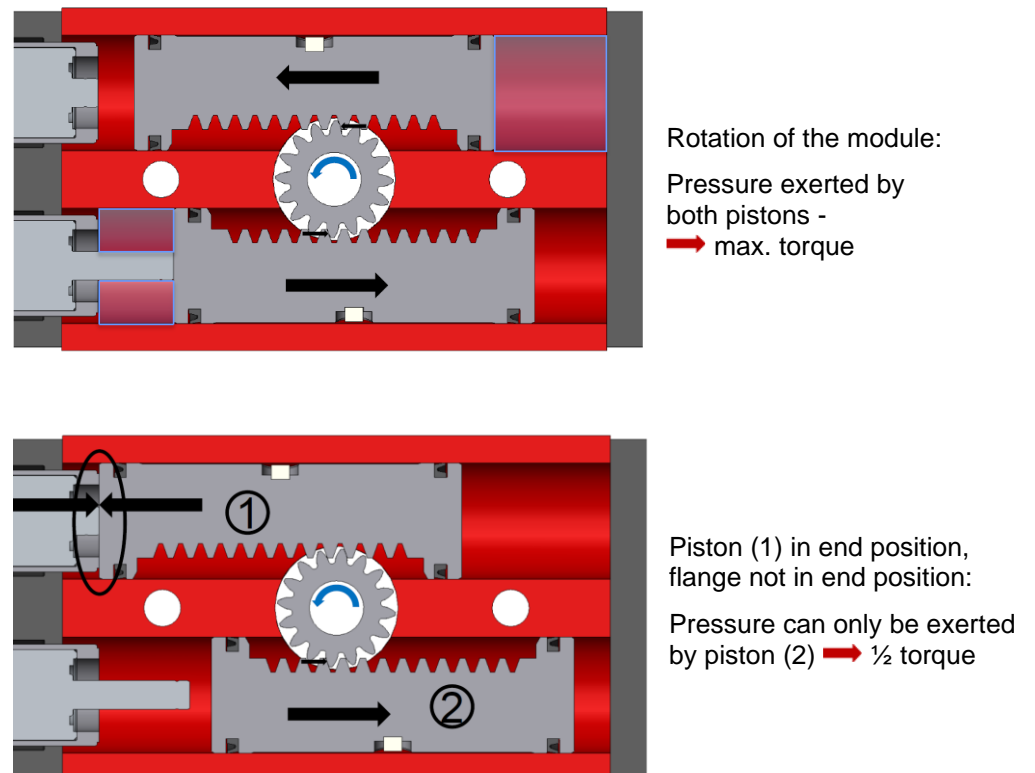

Fig. 15 Exerted pressure of the pistons as a function of the piston position

6 Installation, assembly & setting

This chapter contains specific safety instructions and information regarding proper installation, assembly and setting of the rotary modules including their connection to the control unit and the pneumatic system.

6.1 Safety instructions for installation & assembly

CAUTION



Danger of injury when connecting the rotary modules to the control unit and the compressed-air system!

When connecting the rotary modules to the control unit or the compressed-air system sudden, unpredictable movements may occur which can cause personal injury or property damage.

- The connecting work may only be carried out by qualified personnel!
 - Read carefully the assembly and safety instructions before working with or on the rotary modules.
-

CAUTION



Danger of injury when handling the rotary modules!

Careless handling of the rotary modules can cause personal injuries and damage to the rotary modules.

- Only qualified personnel may work with or on the module!
 - Observe the assembly instructions!
-

NOTICE

No liability for damages can be assumed for damages caused by improper installation/assembling work on the part of the operator.



Also observe the safety instructions in  chap. 2 „Safety instructions“ in this manual.

6.2 Installation and assembly

6.2.1 Assembly and attachment

In order to ensure high and repetitive accuracy of fit during assembling, operation and exchanging of a module, the components of the Afag modules are provided with a precise module centering unit.



The rotary modules can be mounted both in horizontal and vertical position.

Attachment options

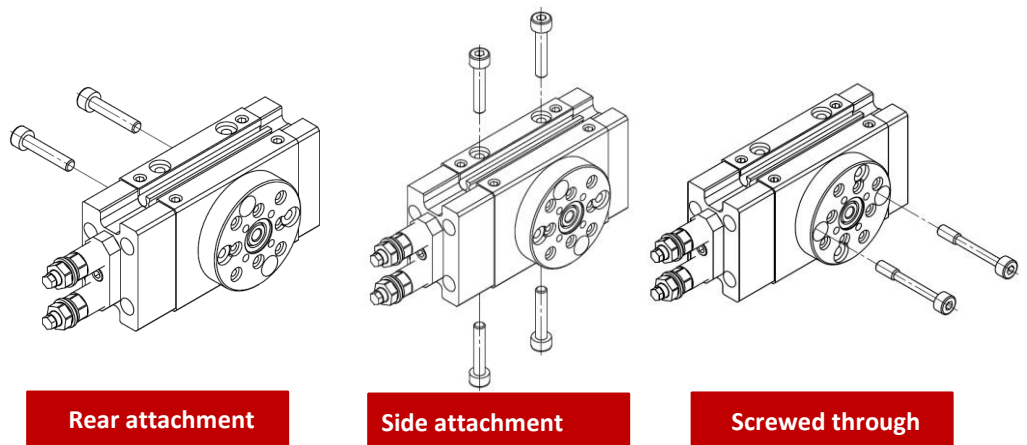

Fig. 16 Attachment options rotary modules

Centring bushing and hole grid

Designation	CR 12	CR 16 / CR 20
Hole grid	30 mm	48 mm (30)
Thread/Bore	2 x M4	2 x M6
Centering bushing	7x3 mm	7x3 mm, 9x4 mm



Order numbers of the special screws:

Rotary module CR 12: M4x30, Order no.: 50001374

Rotary module CR16 / CR 20: M6x36, Order no.: 11005014



Use the supplied centering bushings to position the rotary modules. Insert the centering bushings in two diagonally opposite holes of the attachment grid.

The dimensions of the mounting holes and the distances between holes are indicated in the dimensional drawings in chap. 3 „Technical data“.

Installation, assembly & setting

Centering bushings	Ø4x2	Ø5x2.5	Ø7x3	Ø8x3.5	Ø9x4	Ø12x4.8	Ø19x5.8
Order number	50332257	50035831	11016850	50263565	11004942	50187424	50189497
Net weight	0.001 kg	0.001 kg	0.001 kg	0.001 kg	0.001 kg	0.002 kg	0.006 kg
A	4 mm	5 mm	7 mm	8 mm	9 mm	12 mm	19 mm
B	2 mm	2.5 mm	3 mm	3.5 mm	4 mm	4.8 mm	5.8 mm
C	2.6 mm	3.2 mm	4.3 mm	5.4 mm	6.5 mm	8.5 mm	13 mm

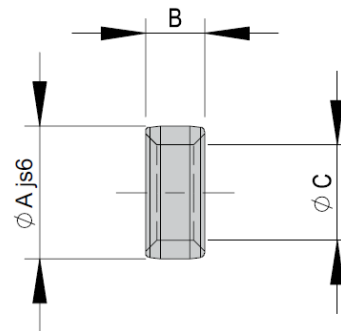

Bores							
Ø A*	19H7	12H7	9H7	8H7	7H7	5H7	4H7
Ø B	13	8.5	6.5	5.4	4.3	3.2	2.6
Ø C	M12	M8	M6	M5	M4	M3	M2.5
D	3.0 (+0.1/0)	2.5 (+0.1/0)	2.1 (+0.1/0)	1.8 (+0.1/0)	1.6 (+0.1/0)	1.3 (+0.1/0)	1.1 (+0.1/0)

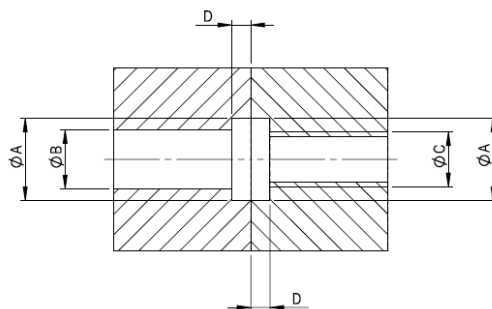

*for several old modules, the bores are still K7 tolerated.

Attachment grid	16x16 mm	20x20 mm	30x30 mm	38x38 mm	48x48 mm	60x60 mm	75x75 mm	96x96 mm
A	16 mm	20 mm	30 mm	38 mm	48 mm	60 mm	75 mm	96 mm
B	8 mm	10 mm	15 mm	19 mm	24 mm	30 mm	37.5 mm	48 mm
C	4x1.1 mm	5x1.3 mm	7x1.6 mm	8x1.8 mm	9x2.1 mm	12x2.5 mm	15x2.7 mm	19x3 mm
D	M2.5	M3	M4	M5	M6	M8	M10	M12

Module-centering, centering bushings

In order to guarantee a high and repetitive fit accuracy during installation, operation or replacement of a module, all components of the entire program are consequently provided with a precise module centering. Centering bushings or pins are supplied as standard with each module.

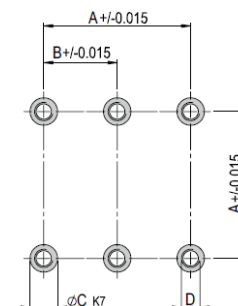

6.2.2 Tightening torques for screws

For assembling use screws with the following minimum specifications:

Standard	VDI 2230
Screw strength	Category 8.8
Surface:	Galvanized blue, oiled or greased

Thread	Tightening torque
M3	1.1 ... 1.4 Nm
M4	2.6 ... 3.3 Nm
M5	5.2 ... 6.5 Nm
M6	9.0 ... 11.3 Nm
M8	21.6 ... 27.3 Nm

6.2.3 Connection to the pneumatic system

WARNING



Danger when connecting to pneumatics!

The pneumatic system can pose various hazards that can cause serious or fatal injuries if the work is carried out improperly.

- Only qualified personnel may work with or on the pneumatic system!
- The necessary personal protective equipment must be provided and used.

NOTICE

Functional impairment to leaking compressed air connections!

Unused air connections that are not hermetically sealed lead to a pressure loss and thus to functional impairment.

- Before installing the module in a system, all unused compressed air connections must hermetically sealed.
- Perform a leak test!



When connecting the compressed air supply for the first time, make sure that all compressed air throttles are closed.

Vent the system slowly!



The minimum compressed air quality shall comply with the specifications of ISO 8573-1:2010.

Pneumatic connections rotary modules CR 12, CR 16 and CR 20

The CR rotation module has 5 selectable pneumatic connection options for each direction of rotation.

(1) Upper module half: 5 connections, clockwise direction of rotation

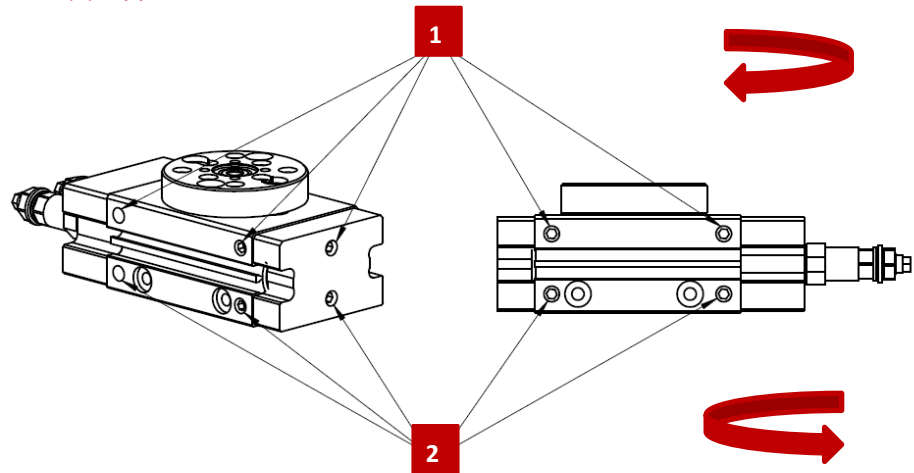

(2) Lower module half: 5 Connections, counterclockwise direction of rotation

Fig. 17 Pneumatic connection CR & CR-ZA

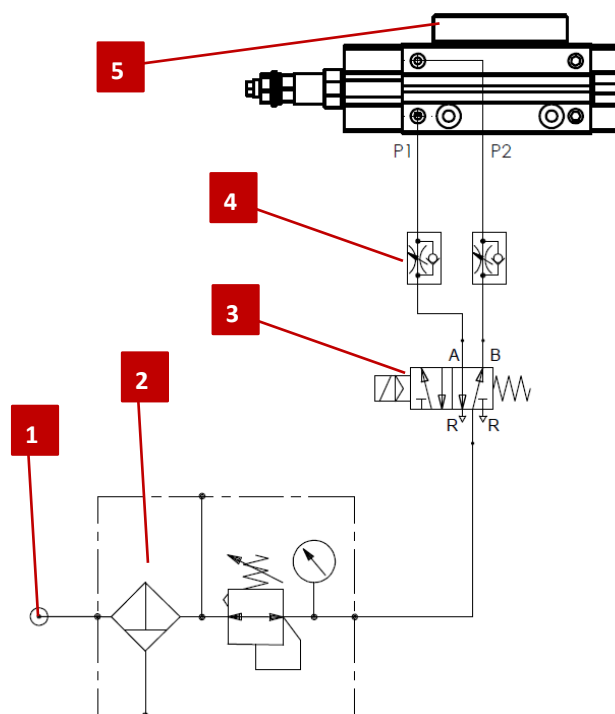

Fig. 18 Pneumatic circuit diagram CR rotary modules

- | | |
|------------------------------|---------------------|
| 1. Compressed air connection | 4. Throttle valve |
| 2. Maintenance unit | 5. Rotary module CR |
| 3. 4/2 (5/2) Way-valve | |

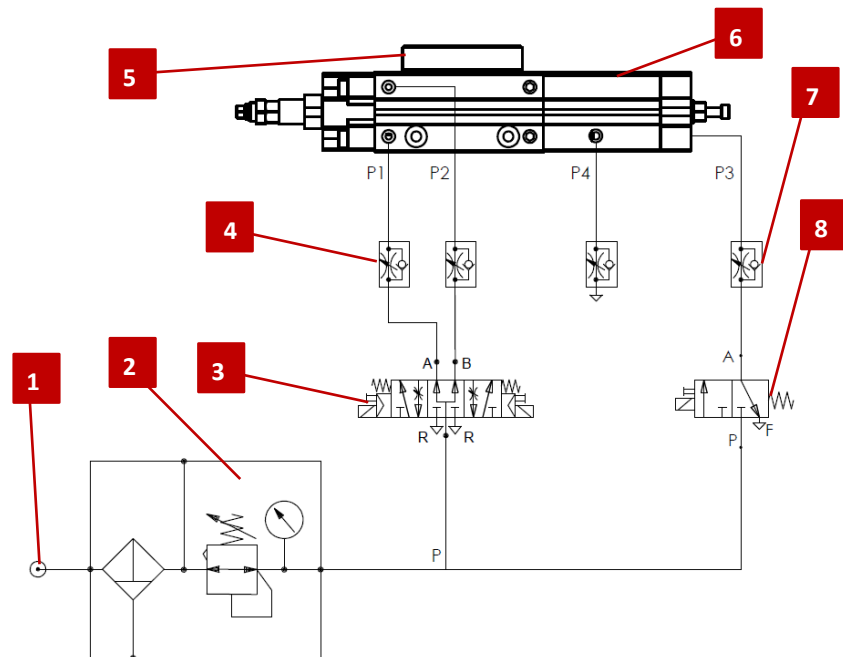

Fig. 19 Pneumatic circuit diagram CR-ZA with intermediate positions

- | | |
|------------------------------|---|
| 1. Compressed air connection | 5. Rotary module CR |
| 2. Maintenance unit | 6. Intermediate position cylinder for CR |
| 3. 5/3 Way-valve | 7. Throttle check valve (damping intermediate pos.) |
| 4. Throttle check valve | 8. 3/2 Way-valve |

6.2.4 Assembling, monitoring, replacement of the sensors

On both sides of the module there are two C-slots for the magnetic field sensors (accessories see ➔ chapter 5.3). The end positions are scanned with two magnetic field sensors.

The intermediate position module (CR-ZA) also has two C-slots on each side. Here, the intermediate positions are scanned with one magnetic field sensor.

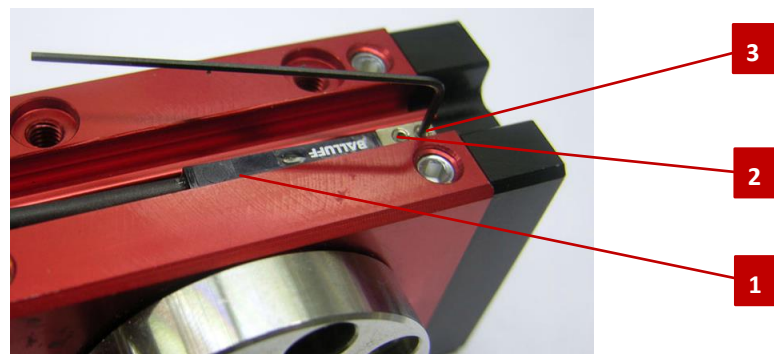

Fig. 20 Illustration of magnetic field sensors

1. Sensor (accessories)
2. Clamping screws (sensor and slot nut)
3. Fixing screw for sensor in the C-slot

Installation of the sensors

Proceed as follows to install the sensors:

1. Insert the sensor (Fig. 20, 1) with the mounted slot nut into the C-slot.
2. Connect the sensor to the control system.
3. Carry out a function check on the rotary module and check whether the sensor switches correctly.
4. Adjust the position of the rotary module.
5. Set the sensor to the desired position.
6. Securely fasten the sensor with the fastening screw (Fig. 20, 3).
⇒ The sensor is mounted.

Monitoring of the sensors

The end position monitoring of the rotary modules is carried out by clampable magnetic field sensors. These accessories are listed in ➔ chapter 5.3.

A LED on the sensor is used for function monitoring during end position monitoring.

If the LED does not change its switching state during end position monitoring, the sensor is defective and must be replaced!

NOTICE

Make sure that only the prescribed magnetic field sensors are used!



In combination with magnetic field producing modules, interference may occur when using the magnetic sensors.

Replacing the sensors

Proceed as follows to replace the sensors:

1. Loosen screw (Fig. 21, 2).
2. Remove the built-in sensor (Fig. 21, 1).
3. Assembly the new sensor as described in this chapter.
⇒ The sensor is replaced.



Fig. 21 Magnetic field sensor (example illustration)

6.3 Settings

This chapter contains information on the adjustment work to be carried out on the rotary modules.

NOTICE

No liability can be assumed for damages caused by improper work carried out on the rotary modules on the part of the operator.

6.3.1 Safety notes for settings

WARNING



Danger of injury due to uncontrolled movement of the equipment!

Uncontrolled movements of parts can cause injury to third parties and damage to property.

- Ensure that there are no persons in the working area of the rotary modules.

CAUTION



Danger of injury from uncontrolled restarting of the system/equipment!

Unintentional restarting of the controller or the pneumatic system can cause injuries and material damage.

- When working on the rotary modules, make sure that the control unit and the pneumatic system are switched off and secured against being switched on again.

CAUTION



Danger arising from work carried out improperly!

Improper adjustment work can cause injuries and damage to property.

- Adjustment and conversion work may only be carried out by qualified personnel!



Also observe the safety instructions in  chap. 2 „Safety instructions“ in this manual.

6.3.2 Adjusting the angle of rotation

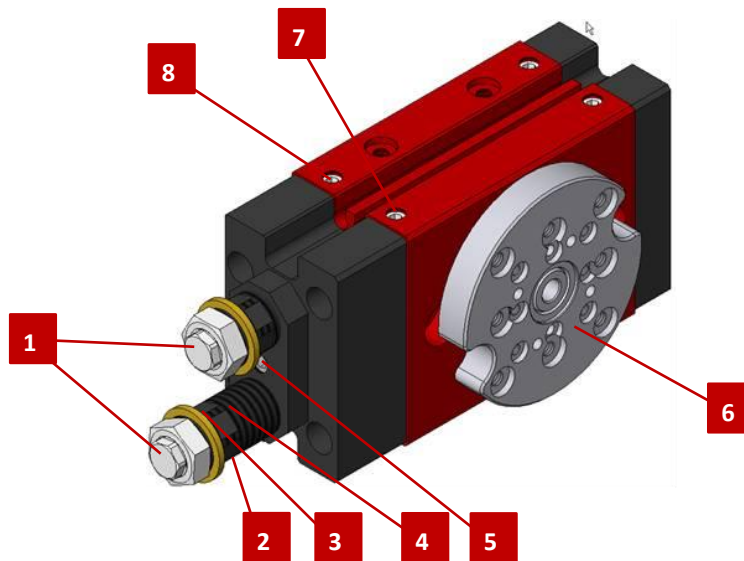

Fig. 22 Example illustration

- | | |
|-------------------|--|
| 1. Shock absorber | 5. Clamping screw |
| 2. Lock nut | 6. Rotary flange |
| 3. Seal | 7. Compr. air connection P2 (clockwise) |
| 4. Stop sleeve | 8. Compressed air connection P1 (counterclockwise) |

Angle of rotation

Maximum rotation angle = 180°

On all modules the hole patterns of the flange are set to 0° position. The flange thus turns 90° to the left and 90° to the right.

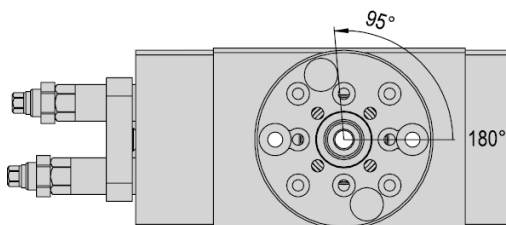
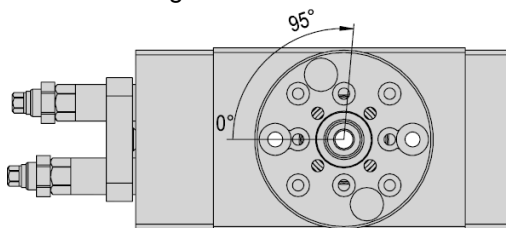
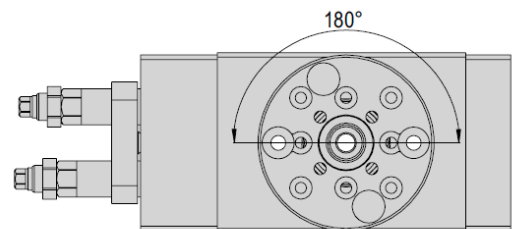

Reduction of the angle of rotation

The end positions can be reduced by max. 95° starting from the 0° or 180° position.

1. Fixation by screwing in the corresponding stop screw.



If the angle of rotation is reduced by more than 95°, a compressed air leakage occurs due to the design. Turn the stop screw back to eliminate the leakage that has occurred.

6.3.3 Setting of the end positions



The exact setting of an end position depends on the stop sleeve, the shock absorber and the adjusted compressed air.

To set the end positions proceed as follows:

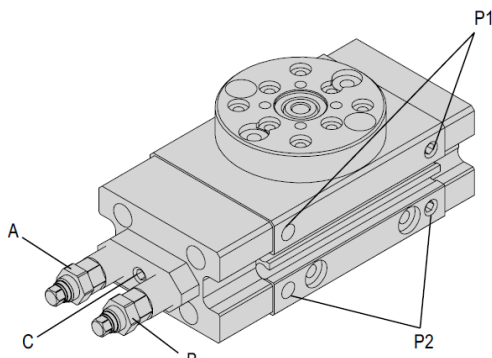

1. Compressed air at P1: Flange rotates clockwise.
 2. Loosen the clamping screw of the of the stop sleeve (Fig. 22, 5).
 3. Turn the hexagon of the stop sleeve (Fig. 22, 4) until the end position is correctly adjusted.
 4. Compressed air at P2: Flange rotates counter-clockwise.
 5. Turn the hexagon of the stop sleeve (Fig. 22, 4) until the desired end position is reached.
 6. Tighten the clamping of the stop sleeves with the clamping screw (Fig. 22, 5).
- ⇒ The end positions are set.

6.3.4 Setting of the end position damping

To adjust the end position damping proceed as follows:

1. Loosen the hexagon nut (Fig. 22, 2) on the shock absorber.
 2. Screw in or out both shock absorbers (Fig. 22, 1) with the small hexagon:
 - the damping becomes harder when screwed in
 - the damping becomes softer when screwed out
- ⇒ The end position damping is set.



If the damping function is not yet optimal, it can also be adjusted with a compressed air throttle.

6.3.5 Adjusting the shock absorber

Maximum damping effect

The maximum damping effect is achieved when the shock absorbers are fully screwed into the stop sleeve (mechanical stopper).

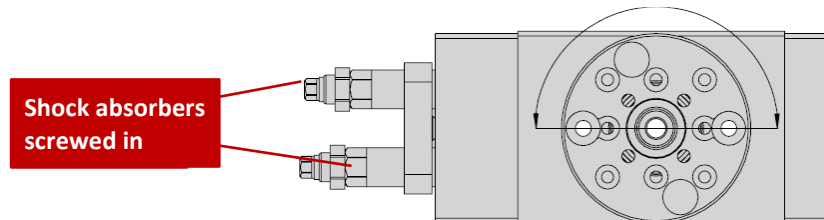

Reduced damping effect

The damping effect is reduced by turning back the shock absorbers. This is useful for low loads and/or slow rotation speeds.

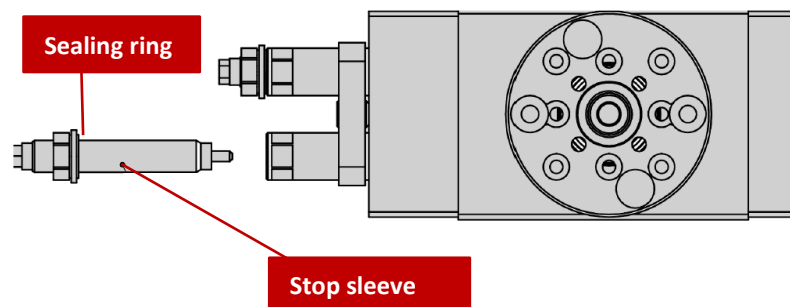

NOTICE

Material damage due to operation without shock absorbers!

Operation of the rotary modules without shock absorbers leads to mechanical damage and loss of warranty.

- Always operate the rotary modules with shock absorbers!

NOTICE

Material damage due to improper assembly!

Do not push the threaded sealing ring onto the shock absorber as the sealing lips will be damaged and the rotary module will become leaky.

- Carefully screw the threaded sealing ring onto the shock absorber!



When removing or mounting a shock absorber, make sure that the sealing ring fits exactly against the stop sleeve before tightening the lock nut!

6.3.6 Setting of intermediate positions

Legend	
	Retracted
	Lock nut
	Positioning pin 1
	Positioning pin 2
	extended

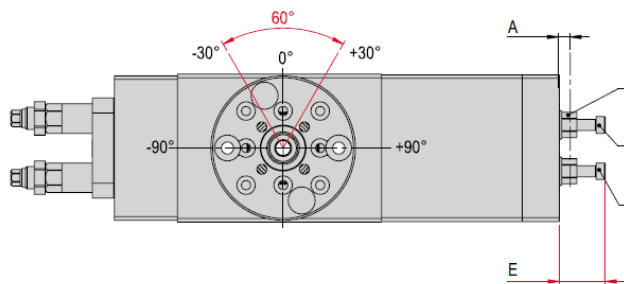

Intermediate positions

With the intermediate stop module ZA, up to two intermediate positions can be approached.

Adjustment range of the intermediate position(s)

The maximum setting range is 60° (30° to the left and 30° to the right) when viewed from the 0° position.

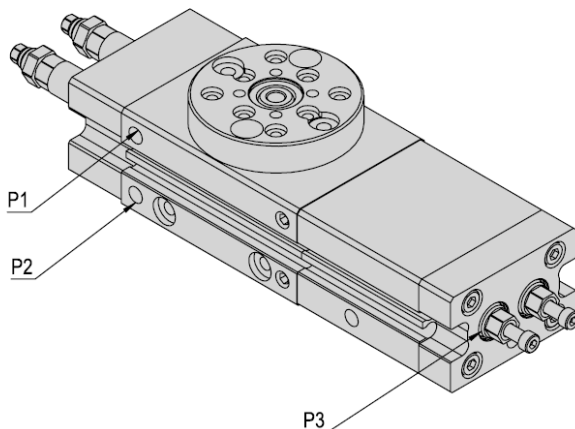

Setting of intermediate positions:

1. Loosen both lock nuts B and unscrew both position pins C and D completely (up to the mechanical stop).
2. Insert the lock nuts B to ensure tightness during subsequent ventilation.
3. Insert position pins C, D manually and ventilate at P3 with operating pressure.
4. Venting of P1. The shaft rotates clockwise.
5. Set the desired intermediate position with position pin 1.
6. Counter the position pin 1.
7. Venting of P2. The shaft rotates counterclockwise.
8. Screw in position pin 2 until resistance can be felt.
9. Counter the position pin 2. Both position pins now touch the pistons of the rotary module.



For the CR rotary modules with intermediate position, an exhaust air throttle must be installed on the ZP (intermediate position) side.

The exhaust air throttle also regulates the damping behaviour of the intermediate position.

6.3.7 Approaching the intermediate positions

Position	P1*	P2*	P3*
-90°	0	1	0
-15°	0	1	1
+20°	1	0	1
+90°	1	0	0

*P1, P2, P3=Air connections 0=unpressurised 1=pressurised

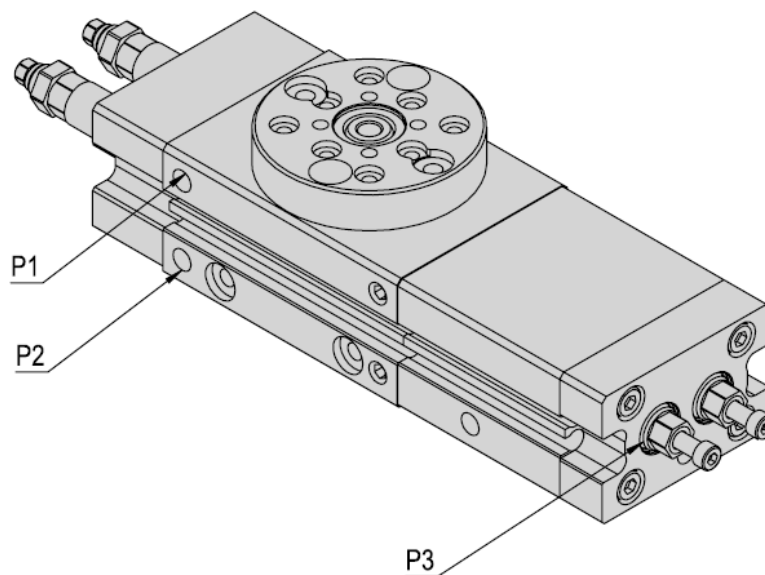
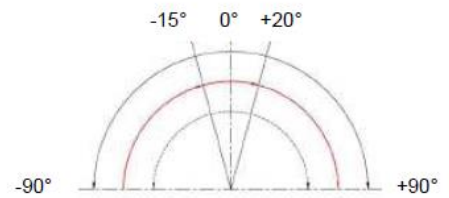

Fig. 23 Positions (example illustration)

7 Commissioning

This chapter contains information on how to commission the rotary modules. After connection to the pneumatic system and mounting of the sensors, the rotary modules are commissioned for the first time via the system control.

7.1 Safety instructions for commissioning

CAUTION



Danger of injury by moving components!

Limbs can be crushed by moving components!

- Work on and with the rotary modules may only be carried out by qualified personnel.
- Make sure that there are no persons or tools in the working area of the rotary modules.

CAUTION



Danger of injury in the working area of the rotary modules!

During operation of the rotary modules, persons within the working area of the modules may be injured.

- When operating the rotary modules, ensure a good overview of the entire working area.
- Unauthorized persons must not stay within the working area during operation.



Also observe the safety instructions in  chap. 2 „Safety instructions“ in this manual.

7.2 Commissioning of the modules



Before commissioning, adjust the shock absorbers and stop sleeves so that the desired angle of rotation is damped correctly.

Proceed carefully and follow the instructions step by step when commissioning the modules for the first time:

1. Slowly ventilate the entire system.
 2. Note the permissible values of the rotary module ( Chapter 3) for:
 - payload
 - movement frequency
 - mechanical stress
 3. Make sure that there are no persons or tools within the working area of the rotary module.
 4. Perform test run:
 - Start with slow traversing movements,
 - then continue under normal operating conditions.
- ⇒ Commissioning is completed.

8 Fault elimination

8.1 General notes

This chapter contains general information and safety instructions for troubleshooting.

8.2 Safety instructions for troubleshooting

WARNING



Danger of injury due to improper work!

Poorly performed troubleshooting work can lead to serious injuries and damage to property.

- The due diligence obligations of the user include ensuring that the personnel working on eliminating faults appropriately trained and qualified.



Also observe the safety instructions in  chap. 2 „Safety instructions“ in this manual.

8.3 Table Fault causes and remedy

The following table contains an overview of possible fault causes and how to proceed to eliminate them. Defective components must be replaced exclusively by Afag original spare parts.

8.3.1 Troubleshooting table

Fault	Possible cause	Remedy:
Module does not rotate	<ul style="list-style-type: none"> ▪ No compressed air ▪ Module incorrectly connected to pneumatics 	<ul style="list-style-type: none"> ▪ Check connections ▪ Check connections
End position signal not clear	<ul style="list-style-type: none"> ▪ Limit stop incorrectly adjusted ▪ Initiator defect ▪ Cable break in sensor cable ▪ Initiator incorrectly positioned 	<ul style="list-style-type: none"> ▪ Readjust limit stop ▪ Replace initiator ▪ Replace initiator cable ▪ Position the initiator correctly
Module hits the end positions	<ul style="list-style-type: none"> ▪ Shock absorber incorrect adjusted ▪ Shock absorber defective ▪ No shock absorber available ▪ Exhaust flow control defective ▪ Lifting speed too high 	<ul style="list-style-type: none"> ▪ Readjust shock absorber ▪ Replace shock absorber ▪ Retrofitting of shock absorber ▪ Replace exhaust flow control ▪ Adjust exhaust flow control

9 Maintenance and repair

9.1 General notes

The rotary modules are almost maintenance-free. Nevertheless, some maintenance work must be carried out to ensure an optimum operating condition of the modules. This chapter describes the required maintenance activities.



Each rotary module is accompanied by a safety information sheet. This information sheet must be read carefully by every person who carries out work on and with the rotary module.

9.2 Safety instructions for maintenance and repair

WARNING

Danger of injury due to improper maintenance!

Improperly carried out maintenance activities can cause considerable damage to property and serious injury.

- The operator must exercise due care and only use trained maintenance personnel to carry out the activities.
 - Always wear personal protective equipment when carrying out maintenance and repair work!
-



WARNING

Risk of injury due to uncontrolled movements of the rotary modules!

Signals from the control system can trigger unintentional movements of the rotary modules, which can cause injury.

- Before starting any work on the rotary modules, switch off the control unit and secure it from being switched on again. Observe the operating instructions of the controller used!
 - Before starting any activities, switch off the media supply (pneumatics) and secure it from being switched on again!
-



Also observe the safety instructions in  chap. 2 „Safety instructions“ in this manual.

9.3 Maintenance activities and maintenance intervals

The rotary modules are almost maintenance-free. Nevertheless, some maintenance work must be carried out to ensure an optimum operating condition of the rotary modules.

9.3.1 Overview of the maintenance points

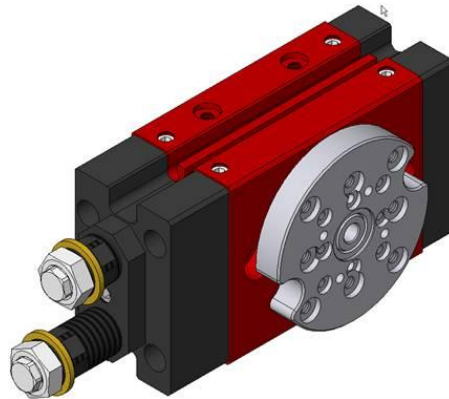





Fig. 24 Maintenance points rotary module

No.	Maintenance point	Maintenance work	Interval	System [On/Off]	Remarks
1	Entire rotary module	Cleaning and checking 	As required	[Off]	- <ul style="list-style-type: none">▪ Clean the rotary module with a dry, lint-free cloth.- Do not spray rotary modules with water, do not use aggressive cleaning agents.▪ Perform a visual inspection of the rotary module.
2	Shock absorber*	Check functioning 	Monthly	[Off]	<ul style="list-style-type: none">▪ Check function of shock absorbers, replace if necessary
3	Stop screws	Check functioning 	Monthly	[Off]	- <ul style="list-style-type: none">▪ Check function of stop screws, replace if necessary
4	Rotary module	Check 	Monthly	[On]	- <ul style="list-style-type: none">▪ Check rotary module for unusual noise generation.



*Shock absorbers and stop screws must be checked regularly for correct function and replaced if necessary. We recommend replacing the shock absorbers after max. 5 million load cycles.

Incorrectly adjusted, missing or defective shock absorbers impair the function of the module and can lead to its destruction!

NOTICE

Risk of damage to property!

Torx-type hexagon socket screws may only be loosened by the manufacturer Afag. Otherwise the rotary modules could be damaged.

- Only **Inbus**-type hexagon socket screw may be loosened by the operator.

NOTICE

Risk of corrosion due to ionized air environment

If the rotary modules are used in an ionised air environment, there is a risk that exposed parts could corrode.

- Always grease exposed parts e.g. flanges, shafts, guides and jaws regularly.
- Afag standard lubrication: Staburax NBU8EP (flat guides), Blasolube 301 (piston rods)

9.3.2 Compressed air specifications

The rotary modules are lifetime lubricated and can be operated with lubricated or non-lubricated compressed air.



Before operating the rotary module CR with oil-free compressed air, make sure that the module has never been operated with oil-lubricated compressed air!

Compressed air specification
Dry (condensation-free)
Filtered (40 µm filter for lubricated air)
Filtered (5 µm filter non-lubricated air)

If the rotary modules are operated with lubricated compressed air, we recommend that you use the following types of oil:

oil type	
Festo Special Oil	Shell Tellus Oel C 10
Avia Avilub RSL 10	Mobil DTE 21
BP Energol HPL 10	Blaser Blasol 154
Esso Spinesso 10	

Oil quantity: 5-10 drops of oil per 1000 ltr. Compressed air

Viscosity range: 9 to 11 mm²/s (= cST) at 40°C, ISO class VG 10 according to ISO 3448

NOTICE

Risk of damage to property!

The operation of the rotary modules with oil-lubricated compressed air causes the factory primary lubrication to be washed out. Therefore, it is absolutely essential that the rotary modules continue to be operated with oil-lubricated compressed air in order to avoid damage to the rotary modules.

- Once the rotary modules have been operated with oil-lubricated compressed air, they **may never be operated without oil-lubricated compressed air**.
-

9.3.3 Further maintenance

Further maintenance is not required, if the ambient conditions listed below are complied with:

- Clean working area
- No use of splash water
- No abrasive or process dust and vapours
- Climate and temperature as specified in the technical data

9.4 Spare parts and repair work

Afag Automation AG offers a reliable repair service. Defective modules can be sent to Afag for warranty repair within the warranty period.

After the warranty period has expired, the customer can replace or repair defective modules or wear parts himself or send them to the Afag repair service.



Please note that Afag does not assume any warranty for modules that have not been replaced or repaired by Afag!

CAUTION

Risk of injury when removing the rotary modules due to uncontrolled movements of the rotary modules!

When disassembling the rotary modules from a system, there is a danger of uncontrolled movements.

- Disconnect the media supply (electrics, pneumatics) before removing the modules!
 - Disassembly should only be carried out by qualified personnel!
 - Bleed and deactivate the equipment before removing the rotary module!
 - Before removing the rotary module, switch off the control unit and secure it against being switched on again!
-



10 Decommissioning, disassembly, disposal

The rotary modules must be properly dismantled after use and disposed of in an environmentally friendly manner.

10.1 Safety instructions for decommissioning, disassembling and disposal

WARNING



Risk of injury due to improper decommissioning, disassembly and disposal!

Improperly carried out activities can result in considerable material damage and serious injury.

- The operator must exercise due care and only use specially trained and qualified personnel for this work.



Also observe the safety instructions in ↻ chap. 2 „Safety instructions“ in this manual.

10.2 Decommissioning

If the rotary modules are not used for a longer period of time, they must be properly commissioned and stored as described in ↻ chapter 4.5.

10.3 Disassembly

The rotary modules may only be dismantled by qualified personnel.

CAUTION



Risk of injury due to uncontrolled movements of the rotary modules!

When disassembling the rotary modules from a system, there is a danger of uncontrolled movements. If pneumatic connections are disconnected under pressure, serious bodily injury may result.

- Disconnect the media supply (electrics, pneumatics) before removing the rotary modules!
- Disassembling should only be carried out by qualified personnel!
- Only remove the rotary module when the control unit is switched off and secured!

10.4 Disposal

The rotary modules must be disposed of properly at the end of their service life and the raw materials used must be recycled. Observe the legal regulations and company requirements.

The rotary modules must not be disposed of as a complete unit. Dismantle the rotary module into individual parts and separate the various components according to type of material and dispose of them properly:

- Scrap the metallic materials.
- Hand over plastic parts for recycling.
- Sort the rest of the components by their material properties and dispose of them accordingly.

NOTICE

Risk to the environment due to incorrect disposal of the packaging material!

Environmental damage can be caused by incorrect disposal of the packaging material.

- Electronic parts, electrical scrap, auxiliary and operating materials must be disposed of by approved specialist companies.
 - Information on proper disposal can be obtained from the responsible local authorities.
-

11 Declaration of incorporation

Declaration of incorporation

for partly completed machinery according to the Machinery Directive 2006/42/EC, Annex II, 1.B

The manufacturer hereby declares:

Afag Automation AG, Luzernstrasse 32, CH-6144 Zell

that the partly completed machine:

Product description	Compact rotary module (pneumatic)
Type:	CR 12, CR 16, CR 20
Consecutive serial no.	50XXXXXX

complies with the following essential health and safety requirements of the Machinery Directive 2006/42/EC at the time of declaration: 1.1; 1.1.1; 1.1.2; 1.2.3; 1.2.4.4; 1.3; 1.3.5; 1.3.6; 1.3.7; 1.3.9; 1.4.1; 1.5; 1.5.3; 1.5.5; 1.6; 1.6.1; 1.6.3; 1.6.4; 1.7; 1.7.4; 1.7.4.1; 1.7.4.2

Harmonised standards applied, in particular:	
EN ISO 12100:2010	Safety of machinery - General principles for design - Risk assessment and risk reduction.

Note: The partly completed machinery must not be put into service until the machinery into which it is to be incorporated has been declared in conformity with the provisions of Machinery Directive 2006/42/EC.

The manufacturer undertakes to transmit, in response to a reasoned request by the national authorities, relevant technical documentation for the partly completed machinery.

The relevant technical documentation has been created according to Annex VII, Part B of the above-mentioned Directive.

Authorised representative for compiling the technical documentation:

Niklaus Röthlisberger, Product Manager, Afag Automation AG, CH-6144 Zell

Zell, 31.05.2023

Adrian Fuchser



CEO Afag Gruppe

Klaus Bott



CTO Afag Gruppe

Afag Automation AG
Luzernstrasse 32
6144 Zell
Switzerland
T +41 62 959 86 86
sales@afag.com

Afag GmbH
Wernher-von-Braun-Straße 1
92224 Amberg
Germany
T +49 9621 650 27-0
sales@afag.com

Afag Engineering GmbH
Gewerbestraße 11
78739 Hardt
Germany
T +49 7422 560 03-0
sales@afag.com

Afag Automation Americas
Schaeff Machinery & Services LLC.
883 Seven Oaks Blvd, Suite 800
Smyrna, TN 37167
USA
T +1 615 730 7515
nashville@afag.com

Afag Automation APAC
Afag Automation Technology (Shanghai) Co., Ltd.
Room 102, 1/F, Bldg. 56, City Of Elite
No.1000, Jinhai Road, Pudong New District
Shanghai, 201206
China
T +86 021 5895 8065
shanghai@afag.com