

Assembly and operating instructions

Linear Module LM 20 | LM 25

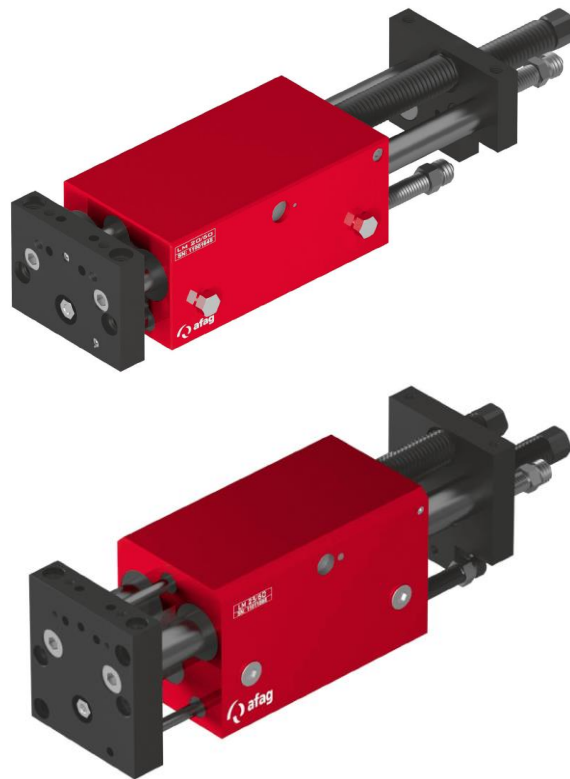

Translation of the Original Assembly Instructions EN

- | | |
|-----------------------------------|-----------------------------------|
| ■ LM 20/30 ⇒ Order no.: 11001720 | ■ LM 25/60 ⇒ Order no.: 11011895 |
| ■ LM 20/60 ⇒ Order no.: 11001645 | ■ LM 25/120 ⇒ Order no.: 11011896 |
| ■ LM 20/90 ⇒ Order no.: 11001646 | ■ LM 25/200 ⇒ Order no.: 11011897 |
| ■ LM 20/120 ⇒ Order no.: 11001647 | |
| ■ LM 20/150 ⇒ Order no.: 11001648 | |
| ■ LM 20/200 ⇒ Order no.: 11009043 | |

Dear Customer

Thank you for choosing our products and placing your trust and confidence in our company!

These assembly and operating instructions contain all essential information you need about your product. Our aim is to provide the required information as concisely and clearly as possible. If, however, you still have any questions on the contents or suggestions, please do not hesitate to contact us. We are always grateful for any feedback.

Our team will also be glad to answer any further question you may have regarding the linear module or other options.

We wish you every success with our products!

With kind regards

Your Afag team

© Subject to modifications

The linear modules have been designed by Afag Automation AG according to the state of the art. Due to the constant technical development and improvement of our products, we reserve the right to make technical changes at any time.

Updates of our documentations



Unlike the printed documents, our digital instructions manuals, product data sheets and catalogues are being continuously updated on our website.

Please keep in mind that the digital documents on our website are always the latest versions.

© Copyright 2023 Afag Automation AG

All contents of the present assembly and operating instructions, in particular the texts, photographs and graphics, are protected by copyright. All rights reserved. No part of these assembly and operating instructions may be reproduced, distributed (made available to third parties), or transmitted in any form or by any means, including photocopying, recording, or other electronic or mechanical methods, without the prior written permission of Afag Automation AG.

Afag Automation AG
Luzernstrasse 32
CH-6144 Zell (Switzerland)
Tel.: +41 62 959 86 86
e-mail: sales@afag.com
Internet: www.afag.com

Table of contents

1	General	5
1.1	Contents and purpose of these assembly instructions.....	5
1.2	Explanation of symbols.....	5
1.3	Additional symbols.....	6
1.4	Applicable documents	7
1.5	Warranty	7
1.6	Liability.....	7
2	Safety instructions	8
2.1	General.....	8
2.2	Intended use.....	8
2.3	Foreseeable misuse	8
2.4	Obligations of the operator and the personnel	9
2.4.1	Observe the assembly instructions	9
2.4.2	Obligations of the operating company.....	9
2.4.3	Obligations of the personnel	10
2.5	Personnel requirements	10
2.5.1	Personnel qualification	10
2.6	Personal protective equipment (PPE)	11
2.7	Changes & Modifications	11
2.8	General hazards / residual risks.....	12
2.8.1	General hazards at the workplace	12
2.8.2	Mechanical hazards	12
2.8.3	Danger due to electricity	13
2.8.4	Danger due to pneumatics	13
2.8.5	Noise hazards	13
3	Technical data	14
3.1	Linear module LM 20.....	14
3.1.1	Dimensional drawing LM 20.....	14
3.1.2	Technical data LM 20	15
3.1.3	Preferred combinations LM 20	16
3.1.4	Slide loads LM 20.....	17
3.2	Linear module LM 25.....	18
3.2.1	Dimensional drawing LM 25.....	18
3.2.2	Technical data LM 25	19
3.2.3	Preferred combinations LM 25	20
3.2.4	Slide loads LM 25.....	21
4	Transport, packaging and storage	22
4.1	Safety instructions for transport.....	22
4.2	Scope of supply	23
4.3	Transport	23
4.4	Packaging.....	24
4.5	Storage	24
5	Design and description	25

5.1	Structure linear module	25
5.2	Product description.....	25
5.3	Accessories	26
5.3.1	Accessories LM 20.....	26
5.3.2	Accessories LM 25.....	26
6	Installation, assembly and setting	27
6.1	Safety Instructions for installation and assembly	27
6.2	Assembly and attachment	28
6.2.1	Attachment options.....	28
6.2.2	Mounting the modules	29
6.2.3	Tightening torques.....	29
6.3	Pneumatic connections	30
6.4	Mounting of initiators	31
6.4.1	Mounting the initiator 6.5 mm.....	32
6.4.2	Mounting initiator 8x8 mm	32
6.5	Mounting 3. position	33
6.6	Attachment intermediate stop.....	34
6.6.1	Attachment intermediate stop	34
6.6.2	Pneumatic connections intermediate stop (ZA 20/25)	35
6.7	Mounting bracket or intermediate plate - LM 25.....	36
6.8	Combination of linear modules	37
7	Commissioning	38
7.1	Safety instructions for commissioning	38
7.2	Preparatory activities for commissioning.....	38
7.2.1	Adjustment of stroke and stop screws (with stop pin).....	39
7.3	Commissioning of the modules	41
8	Fault elimination.....	42
8.1	Safety instructions for troubleshooting	42
8.2	Fault causes and remedy	42
9	Maintenance and repair	43
9.1	General notes	43
9.2	Safety instructions for Maintenance and Repair	43
9.3	Maintenance activities and maintenance intervals.....	44
9.3.1	Overview of the maintenance points	44
9.3.2	Further maintenance	44
9.3.3	Compressed air specification	45
9.4	Spare parts and repair.....	46
9.4.1	Spare and wear parts (LM 20 and LM 25)	46
9.4.2	Replace wear parts	47
10	Decommissioning, disassembly, disposal.....	49
10.1	Safety instructions	49
10.2	Decommissioning	49
10.3	Disposal.....	49
11	Declaration of incorporation.....	50

1 General

1.1 Contents and purpose of these assembly instructions

These assembly instructions contain important information on assembly, commissioning, functioning and maintenance of the linear module LM 20 and LM 25 to ensure safe and efficient handling and operation.

Consistent compliance with these assembly instructions will ensure:

- permanent operational reliability of the module,
- optimal functioning of the module,
- timely detection and elimination of defects (thereby reducing maintenance and repair costs),
- prolongation of the module service life.

The illustrations in this manual shall provide you with a basic understanding of the module and may vary from the actual design of your module.

1.2 Explanation of symbols

The safety notes are marked by a pictogram and a signal word. The safety notes describe the extent of the hazard.

DANGER



Danger!

This safety note indicates an imminently hazardous situation which, if not avoided, will result in death or serious injury.

WARNING



Warning!

This safety note points out a potentially hazardous situation which, if not avoided, could result in death or serious injury.

CAUTION



Caution!

This safety note points out a potentially dangerous situation which, if not avoided, can result in minor or slight injuries.

NOTICE





This safety note points out a potentially dangerous situation which, if not avoided, can cause substantial damage to property and the environment.



This note contains important additional information as well as useful tips for safe, efficient and trouble-free operation of the module.

Further warning signs:

Where applicable, the following standardised symbols are used in this manual to point out the various potential health risks.

	Warning - Dangerous electrical voltage.
	Warning - Risk of injury from contact with hot surfaces.
	Warning - Risk of hand and finger injury due to uncontrolled movements of components.
	Warning - Risk of injury as a result of parts being flung out!
	Warning -high noise levels

1.3 Additional symbols

In these assembly instructions the following symbols are used to highlight instructions, results, references, etc..

Symbol	Description
1.	Instructions (steps ...)
⇒	Results of actions
↻	References to sections
■	Enumerations not ordered

1.4 Applicable documents



Each linear module is accompanied by a safety information sheet. This information sheet must be read carefully by every person who carries out work on and with the module.

1.5 Warranty

The warranty terms for Afag handling components and handling systems are the following:

- 24 months from initial operation and up to a maximum of 27 months from delivery.
- Wear parts are excluded from the warranty (The customer is entitled to a product free of defects. *This does also apply to defective accessories and wear parts. Normal wear and tear are excluded from the warranty.*)

The warranty covers the replacement or repair of defective Afag parts. Further claims are excluded.

The warranty shall expire in the following cases:

- Improper use of the module.
- Non-observance of the instructions regarding assembly, commissioning, operation and maintenance of the module.
- Improper assembly, commissioning, operation and maintenance.
- Repairs and design changes carried out without prior technical instructions of Afag Automation AG.
- Removing the serial number from the product.
- Inadequate checking of wear parts.
- Non-observance of the EC Machinery Directive, the Accident Prevention Regulations, the Standards of the German Electrotechnology Association (VDE) and these safety and assembly instructions.

1.6 Liability

No changes shall be made to the linear module unless described in this instructions manual or approved in writing by Afag Automation AG.

Afag Automation AG accepts no liability for unauthorized changes or improper assembly, installation, commissioning, operation, maintenance or repair work.

2 Safety instructions

2.1 General

This chapter provides an overview of all important safety aspects to ensure safe and proper use of the linear module and optimal protection of personnel. Safe handling and trouble-free operation of the linear module requires knowledge of the basic safety regulations.

Every person carrying out installation, commissioning, maintenance work or operating the module must have read and understood the complete user manual, especially the chapter on safety instructions.

Beyond this, there are rules and regulations regarding accident prevention that are applicable to the place of installation which must be observed.

Improper use may result in danger to life and limb of the user or third parties or in damage to the automation system or other material assets.



Failure to follow the directions and safety instructions given in this instructions manual may result in serious hazards.

2.2 Intended use

The LM 20/ LM 16 module is used for ambient or fixed mounted loads in **non-hazardous** environments in the ambient/application conditions defined (→ chap. 3 "Technical data").

The modules are designed exclusively for the linear movement of payloads **in any position**. The max. permissible payloads on the face plate:

LM 20: 2 to 8 kg, LM 25: 4 to 9 kg (→ chap. 3 "Technical data").

The modules LM 20 and LM 25 can be used in combination with other modules as a pick converted place station, whereby the permissible load capacity must not be exceeded.

Any use beyond the described purpose is considered to be not in accordance with the intended use.

The intended use of the module also includes:

- observance of all instructions given in this instructions manual.
 - compliance with the inspection and maintenance work and the specifications in the data sheets,
 - using only original spare parts.
-



2.3 Foreseeable misuse

Any use other than or beyond the intended use described above is considered a misuse of the linear compensation.

Especially the following use is considered a misuse:

- Use in potentially explosive atmospheres.

WARNING



Risk of injury if the module is not used as intended!

The improper use of the linear modules poses a potential hazard to the personnel.

- The linear modules may only be used in a technically perfect condition in accordance with its intended use and the instructions in this manual as well as in compliance with the safety requirements!
- Any malfunctions, particularly those that could impair safety, must be eliminated immediately!



Risks can occur if the module is not used as intended. In the event of damages caused by improper use the following shall apply:

- the operating company shall be solely responsible for such damage, and
- Afag does not accept any liability for damage caused by improper use.

2.4 Obligations of the operator and the personnel

2.4.1 Observe the assembly instructions

A basic prerequisite for safe and proper handling of the linear module is a good knowledge of the basic safety instructions.



These assembly instructions, in particular the safety instructions contained therein, must be observed by all persons working with the linear module.

2.4.2 Obligations of the operating company

In addition to the safety instructions given in this manual, the operating company must comply with the safety, accident prevention and environmental protection regulations valid for the field of application of the linear module.

The operating company is required to use only personnel who :

- have the necessary professional qualifications and experience,
- are familiar with the basic rules regarding occupational safety and accident prevention,
- have been instructed in the correct handling of the stroke linear module,
- have read and understood these assembly instructions.

The operating company is also required to:

- monitor on an ongoing basis that the personnel work safely considering any potential hazard involved and the assembly instructions are observed,
- ensure that the assembly instructions are always kept at hand at the installation in which the modules are mounted,
- observe and communicate universally applicable laws and regulations regarding accident prevention and environmental protection,
- provide the necessary personal protective equipment (e.g., protective gloves) and instruct the personnel to wear it.

2.4.3 Obligations of the personnel

All personnel working with the are required to:

- read and observe these assembly instructions, especially the chapter on safety,
- observe the occupational safety and accident prevention regulations,
- observe all safety and warning signs on the module,
- refrain from any activity that might compromise safety and health.



In addition, the personnel must wear the personal protective equipment required for carrying out their work (➔chap. 2.6).

2.5 Personnel requirements

2.5.1 Personnel qualification

The activities described in the assembly instructions require specific requisites at the level of professional qualifications of the personnel.

Personnel not having the required qualification will not be able to assess the risks that may arise from the use of the module thus exposing himself and others to the risk of serious injury. Therefore, only qualified personnel may be permitted to carry out the described activities on the linear module. Persons whose ability to react is restricted due to the intake of medication or the like must not interact with the linear module.

These installation instructions are intended for skilled personnel (installers, system integrators, maintenance personnel, technicians), electricians and operating personnel.

The following is a description of the professional skills (qualifications) required for carrying out the different activities:

Qualified personnel:

Qualified personnel with appropriate training who are qualified due to their special know-how and fully familiar with the machine and who have been given instructions on how to carry out the task entrusted to them safely.

Operator (trained personnel):

Authorized persons who due to their specialized professional training, expertise and experience are capable of identifying risks and preventing possible hazards arising from the use of the machine.





2.6 Personal protective equipment (PPE)

The personal protective equipment serves to protect the personnel from hazards affecting their safety and health at work.

When working on/with the linear, the personnel must wear the personal protective equipment assigned by the safety officer of the operating company or as required by safety regulations. In addition, the personnel are required to:

- wear the personal protective equipment provided by the operating company (employer),
- check the personal protective equipment for proper condition, and
- immediately notify the person responsible on site of any defects found on the personal protective equipment.

Personal protective equipment and the respective mandatory signs:

	<p><i>Protective clothing</i> is a close-fitting clothing specifically designed to protect personnel from hazards during work.</p>
	<p><i>Protective gloves</i> are specifically designed to protect the personnel against hand injuries (such as cuts, abrasion, burns).</p>
	<p><i>Safety shoes</i> are specifically designed to protect the personnel against foot injuries from crushing, falling objects or slipping on slippery surfaces.</p>
	<p>Hearing protectors are required to protect the personnel against excessive noise levels to prevent noise-induced hearing loss.</p>

2.7 Changes & Modifications

No changes may be made to the linear module which have not been described in these assembly instructions or approved in writing by Afag Automation AG.

Afag Automation AG accepts no liability for unauthorised changes or improper assembly, installation, commissioning, maintenance or repair work.



The linear module may not be changed or modified in any way, except with the prior written consent of Afag Automation AG.

2.8 General hazards / residual risks

Despite the safe design of the linear module and the technical protective measures taken, there still remain residual risks that cannot be avoided, and which present a non-obvious residual risk when operating the module.

Observe the safety instructions in this chapter and in the other sections of this manual to avoid damage to property and dangerous situations for the personnel.

2.8.1 General hazards at the workplace

The modules has been built according to the state-of-the-art and the applicable health and safety requirements. However, improper use of the linear module may cause the following hazards to the personnel:

- danger to life and limb of the operator or third parties,
- on the linear modules themselves,
- property damage.



Always keep the assembly instructions ready at hand at the workplace! Please, also observe:

- the general and local regulations on accident prevention and environmental protection,
- the safety information sheet for the linear module.

WARNING



Danger - Do not use in unsuitable environment !

The linear modules are designed for the application and environmental conditions defined in chapter 3 "Technical data".

- **Only** use the linear module under the defined operating and ambient conditions!

2.8.2 Mechanical hazards

CAUTION



Risk of injuries by moving parts and unexpected movements!

When operating the linear module uncontrolled movements may occur which can cause personal injury or property damage. There is always a risk of injury by moving parts during normal operation.

- Only qualified personnel may work with or on the linear modules.
- Never reach into the system during normal operation!

2.8.3 Danger due to electricity

DANGER



Danger! Risk of electric shock!

If work on electrical components is required, ensure that the work is carried out properly, failure to do so will cause serious or fatal injuries.

- Work on the machine's electrical equipment may only be performed by skilled electrician or trained personnel under the supervision of a skilled electrician in accordance with all relevant electrical regulations.
-

2.8.4 Danger due to pneumatics

WARNING



Risks by the pneumatic system!

If work on electrical components is required, ensure that the work is carried out properly, failure to do so will cause serious or fatal injuries.

- Work on the machine's electrical equipment may only be performed by skilled electrician or trained personnel under the supervision of a skilled electrician in accordance with all relevant electrical regulations.
-

2.8.5 Noise hazards

CAUTION



Noise hazards!

The linear module generates 68 dB(A) during full-load operation. Depending on the add-ons, the environment and the resonance of the protective device these values may be exceeded and expose the operator to a higher noise level.

- It is the responsibility of the operating company to ensure that the permitted noise limit values are not exceeded.
 - If the permitted noise levels cannot be met it must be ensured that the operating personnel wears the required hearing protection.
-

3 Technical data

3.1 Linear module LM 20

3.1.1 Dimensional drawing LM 20

Typ	LM 20/30	LM 20/60	LM 20/90	LM 20/120	LM 20/150	LM 20/200
A	140 mm	200 mm	260 mm	320 mm	380 mm	480 mm
B	129 mm	189 mm	249 mm	309 mm	369 mm	469 mm
C	50 mm	79 mm	109 mm	139 mm	169 mm	219 mm
D	80 mm	110 mm	140 mm	170 mm	200 mm	250 mm
E	1	1	2	2	3	4
F	212 mm	272 mm	332 mm	392 mm	452 mm	552 mm
G			10 mm	24 mm		
H	30 mm	60 mm	90 mm	120 mm	150 mm	200 mm
P	M5	M5	M5	M5	M5	M5

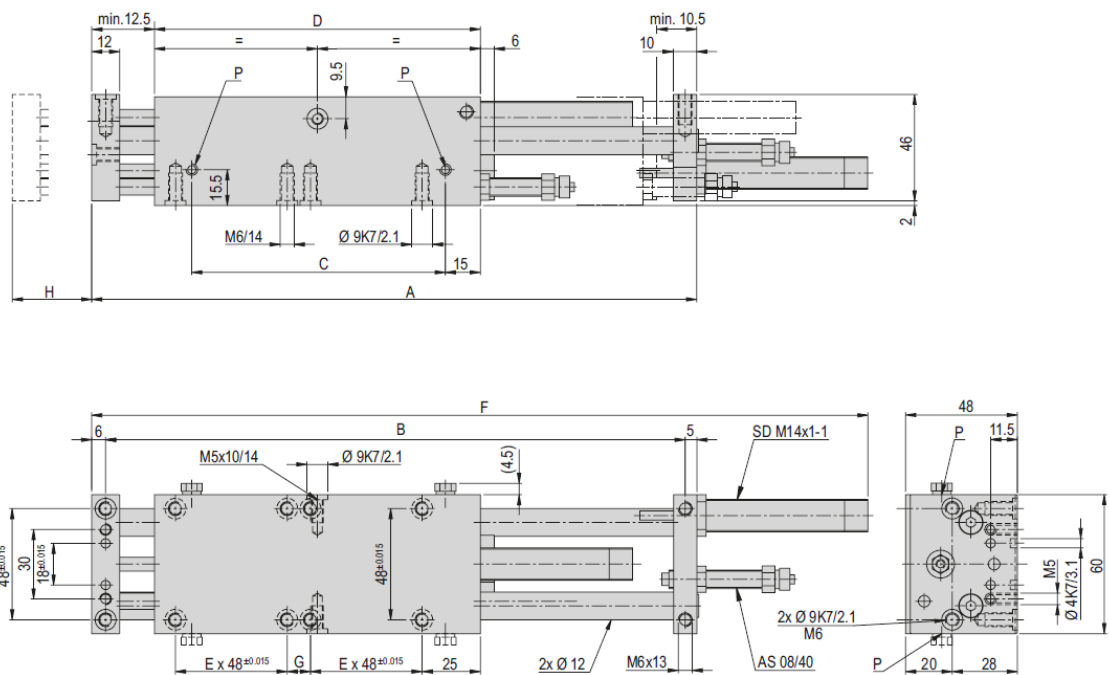







Fig. 1 Dimensional drawing LM 20

3.1.2 Technical data LM 20

LM 20	
Befestigungs raster	48 x 48 mm
Befestigungsgewinde	M6
Betriebsdruck	6 +/- 2 bar
Luftanschluss P	M5
Zylinder Ø	20 mm
Kolbenkraft einfahren	140 N
Kolbenkraft ausfahren	172 N
Betriebstemperatur	0 - 50 °C
Lagerungstemperatur	0 - 50 °C
Luftfeuchtigkeit	< 90 %
Medium gefilterte Druckluft	10 - 40 µm

Typ	LM 20/30	LM 20/60	LM 20/90	LM 20/120	LM 20/150	LM 20/200
Bestellnummer	11001720	11001645	11001646	11001647	11001648	11009043
Hub H	30 mm	60 mm	90 mm	120 mm	150 mm	200 mm
Hubbegrenzung	2 x 25 mm	2 x 25 mm	2 x 25 mm	2 x 25 mm	2 x 25 mm	2 x 25 mm
Nettogewicht	1.28 kg	1.55 kg	1.82 kg	2.1 kg	2.372 kg	2.82 kg
Gewicht bewegt	0.71 kg	0.84 kg	0.97 kg	1.11 kg	1.23 kg	1.44 kg
Luftverbrauch/Zyklus	0.065 NL	0.125 NL	0.19 NL	0.255 NL	0.32 NL	0.43 NL
Lärmpegel	65 dB (A)	65 dB (A)	65 dB (A)	65 dB (A)	65 dB (A)	65 dB (A)
Wiederholgenauigkeit	+/- 0.01 mm	+/- 0.01 mm	+/- 0.01 mm	+/- 0.02 mm	+/- 0.02 mm	+/- 0.02 mm
Anzahl Zwischenanschläge		1	1	1	1	1
Dämpfweg	15 mm	15 mm	15 mm	15 mm	15 mm	15 mm
Einbaulage						

Die technischen Daten beziehen sich auf einen Nenndruck von 6 bar und Afag Standard-Testbedingungen.
Das Modul kann mit geölter oder ölfreier Luft betrieben werden
Reinraumklasse ISO 14644-1, Klasse ISO 7

Im Lieferumfang inbegriffen
(Katalog HT Zubehör)

- 2x Zentrierhülse Ø9x4
- 2x Anschlagsschraube AS 08/40
- 2x Stoßdämpfer SD M14x1 -1

Zubehör

- Basisplatte LM 20 / LM 25 [S. 107]
 - 3. Position LM 20 [S. 107]
 - Zwischenanschlag ZA 20/25 [S. 109]
- (Katalog HT Zubehör)
- Anschlagsschraube AS 08/80
 - Anschlagsschraube AS 08/25
 - INI d6.5x44-Sn1.5-PNP-NO-M8x1

Alternatives Zubehör
(Katalog HT Zubehör)

- INI d6.5x35-Sn1.5-PNP-NO-M8x1

3.1.3 Preferred combinations LM 20

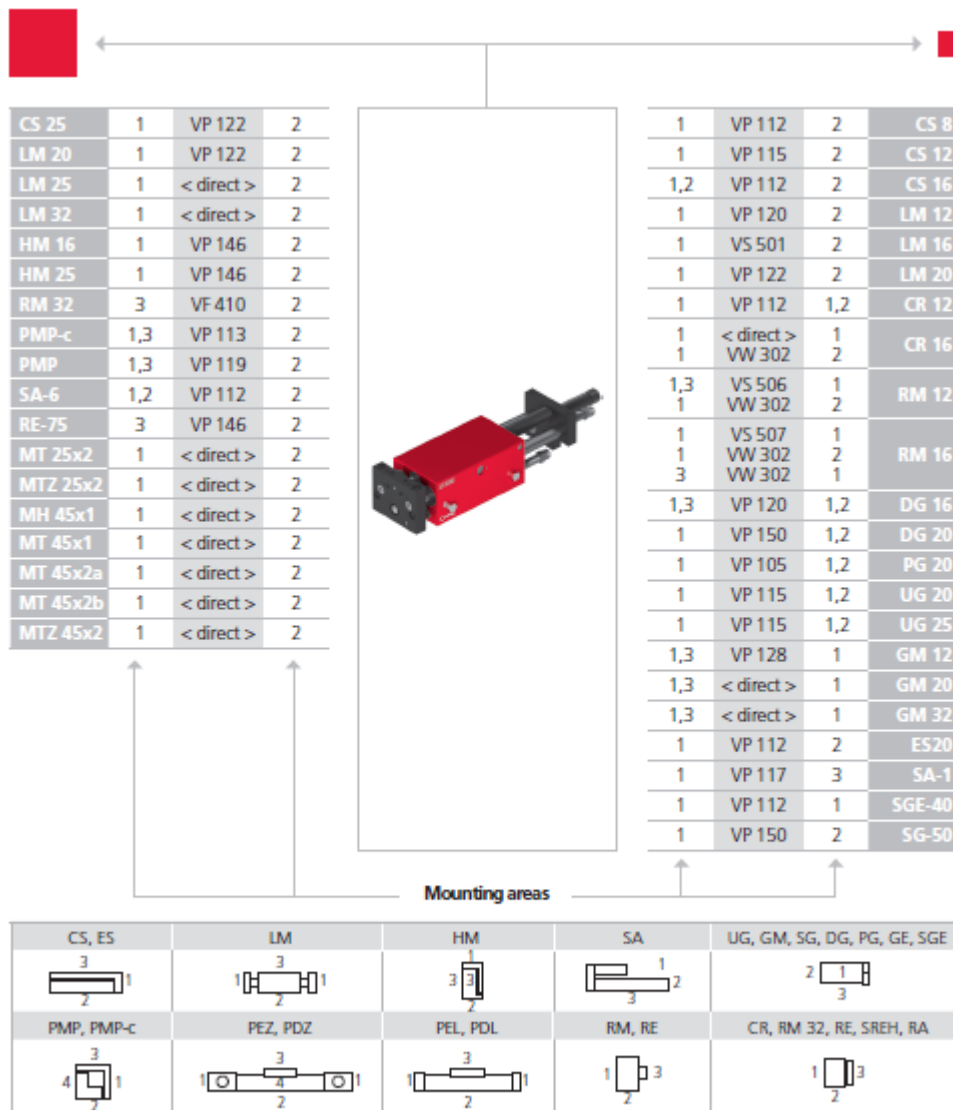

Note that there might be different mounting positions from one module to another one.

The required connection elements and the range of support columns are depicted in the catalogue HT accessories.

Technical data

3.1.4 Slide loads LM 20

Typ	LM 20/30	LM 20/60	LM 20/90	LM 20/120	LM 20/150	LM 20/200
Max statisches Moment Mx	11 Nm	11 Nm	11 Nm	11 Nm	11 Nm	11 Nm
Max statisches Moment My	11 Nm	17 Nm	23 Nm	29 Nm	35 Nm	45 Nm
Max statisches Moment Mz	11 Nm	17 Nm	23 Nm	29 Nm	35 Nm	45 Nm
Max dynamisches Moment Mx	3 Nm	3 Nm	3 Nm	3 Nm	3 Nm	3 Nm
Max dynamisches Moment My	5 Nm	8 Nm	10 Nm	13 Nm	16 Nm	20 Nm
Max dynamisches Moment Mz	5 Nm	8 Nm	10 Nm	13 Nm	16 Nm	20 Nm
Wirkabstand Wx	80 mm	110 mm	140 mm	170 mm	200 mm	250 mm

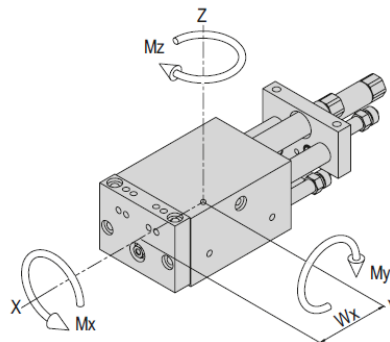

Maximale Nutzlast/Typ	LM 20/30	LM 20/60	LM 20/90	LM 20/120	LM 20/150	LM 20/200
Einbaulage horizontal bei Anbauseite 1	8 kg	7 kg	5 kg	4 kg	3 kg	2 kg
Einbaulage horizontal bei Anbauseite 3	8 kg	7 kg	5 kg	4 kg	3 kg	2 kg
Einbaulage vertikal bei Anbauseite 1	8 kg	7 kg	5 kg	4 kg	3 kg	2 kg
Einbaulage vertikal bei Anbauseite 3	8 kg	7 kg	5 kg	4 kg	3 kg	2 kg

Anbauseiten Moduleinbau

horizontal:



vertikal:



Verfahrzeit-Diagramme

Hubzeit LM 20 mit Stoßdämpfer

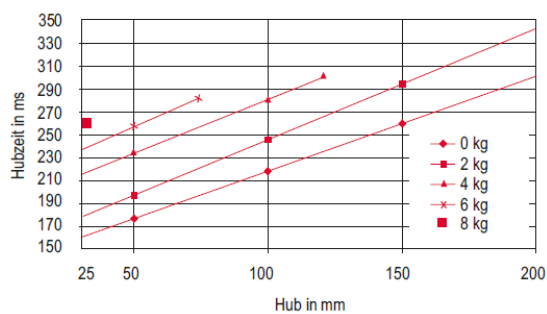

3.2 Linear module LM 25

3.2.1 Dimensional drawing LM 25

Typ	LM 25/60	LM 25/120	LM 25/200
A	202.5 mm	322.5 mm	482.5 mm
B	189 mm	309 mm	469 mm
C	80 mm	140 mm	220 mm
D	110 mm	170 mm	250 mm
E	1	2	4
F	277.5 mm	397.5 mm	557.5 mm
H	60 mm	120 mm	200 mm
P	G 1/8 "	G 1/8 "	G 1/8 "

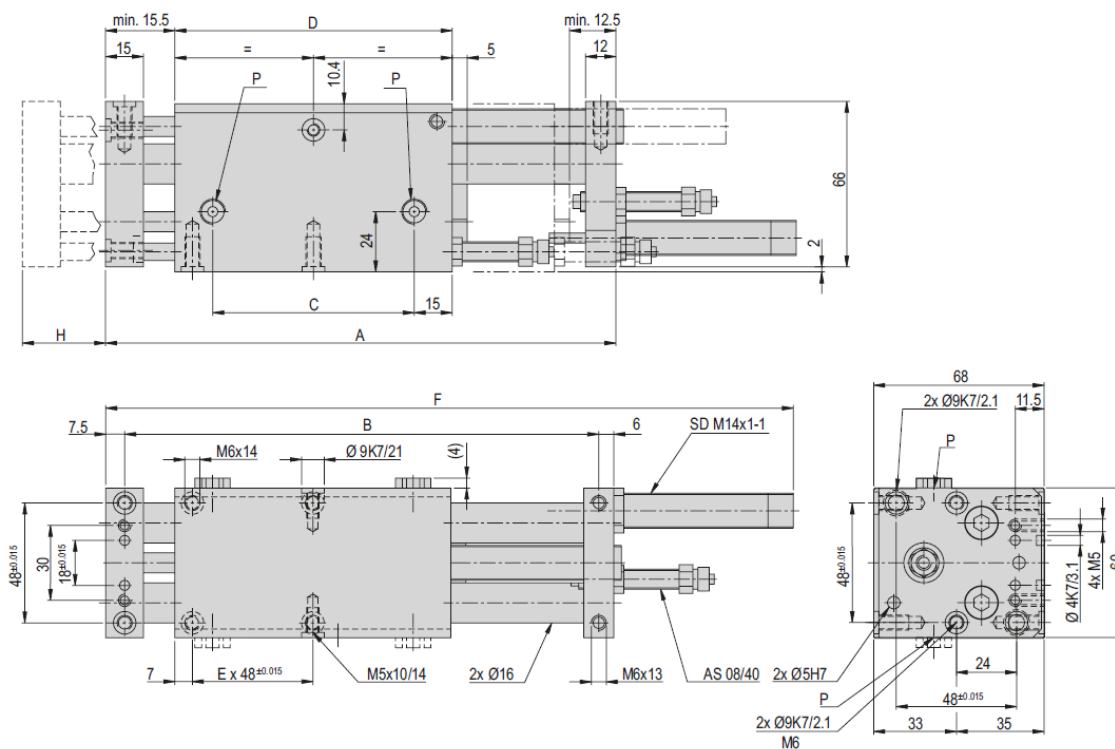

Fig. 2 Dimensional drawing LM 25

3.2.2 Technical data LM 25

LM 25	
Befestigungsraster	48 x 48 mm
Befestigungsgewinde	M6
Betriebsdruck	6 +/- 2 bar
Luftanschluss P	G1/8 "
Zylinder Ø	25 mm
Kolbenkraft einfahren	265 N
Kolbenkraft ausfahren	295 N
Betriebstemperatur	0 - 50 °C
Lagerungstemperatur	0 - 50 °C
Luftfeuchtigkeit	< 90 %
Medium gefilterte Druckluft	10 - 40 µm

Typ	LM 25/60	LM 25/120	LM 25/200
Bestellnummer	11011895	11011896	11011897
Hub H	60 mm	120 mm	200 mm
Hubbegrenzung	2x25 mm	2x25 mm	2x25 mm
Nettogewicht	1.965 kg	2.821 kg	3.944 kg
Gewicht bewegt	0.99 kg	1.43 kg	2.01 kg
Luftverbrauch/Zyklus	0.164 NL	0.33 NL	0.55 NL
Lärmpegel	65 dB (A)	65 dB (A)	65 dB (A)
Wiederholgenauigkeit	+/- 0.01 mm	+/- 0.02 mm	+/- 0.02 mm
Einbaulage	✦	✦	✦

Die technischen Daten beziehen sich auf einen Nenndruck von 6 bar und Afag Standard-Testbedingungen.
Das Modul kann mit geölter oder ölfreier Luft betrieben werden.
Reinraumklasse ISO 14644-1, Klasse ISO 7

Im Lieferumfang inbegriffen
(Katalog HT Zubehör)

- 2x Zentrierhülse Ø9x4
- 2x Anschlagsschraube AS 08/40
- 2x Stoßdämpfer SD M14x1 -1

Zubehör

- Basisplatte LM 20 / LM 25 [S. 107]
 - 3. Position LM 25 [S. 108]
 - Zwischenanschlag ZA 20/25 [S. 109]
- (Katalog HT Zubehör)
- INI d6.5x44-Sn1.5-PNP-NO-M8x1

Alternatives Zubehör
(Katalog HT Zubehör)

- INI d6.5x35-Sn1.5-PNP-NO-M8x1

3.2.3 Preferred combinations LM 25

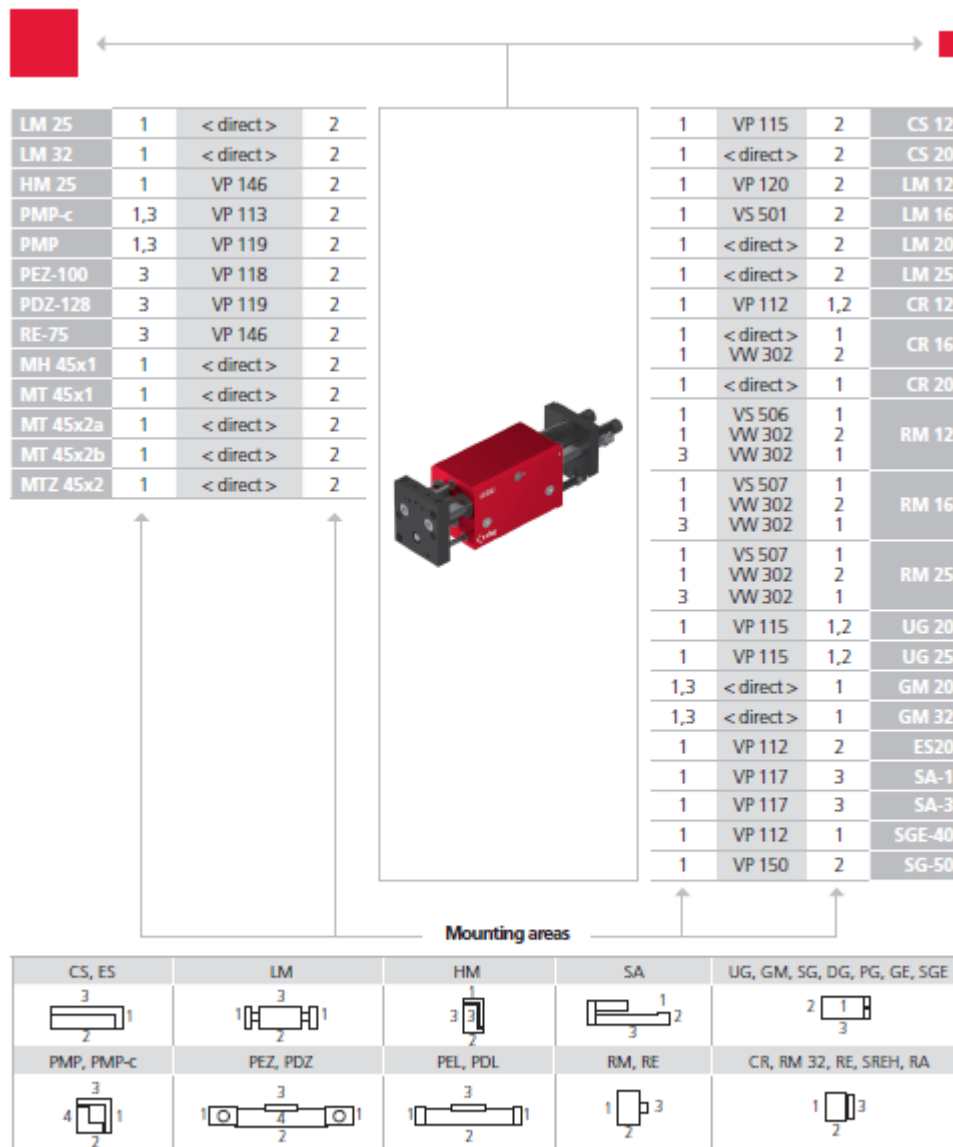

Note that there might be different mounting positions from one module to another one.

The required connection elements and the range of support columns are depicted in the catalogue HT accessories.

Technical data

3.2.4 Slide loads LM 25

Typ	LM 25/60	LM 25/120	LM 25/200
Max statisches Moment Mx	8 Nm	8 Nm	8 Nm
Max statisches Moment My	20 Nm	35 Nm	55 Nm
Max statisches Moment Mz	20 Nm	35 Nm	55 Nm
Max dynamisches Moment Mx	4 Nm	4 Nm	4 Nm
Max dynamisches Moment My	9 Nm	16 Nm	25 Nm
Max dynamisches Moment Mz	9 Nm	16 Nm	25 Nm
Wirkabstand Wx	85 mm	115 mm	145 mm

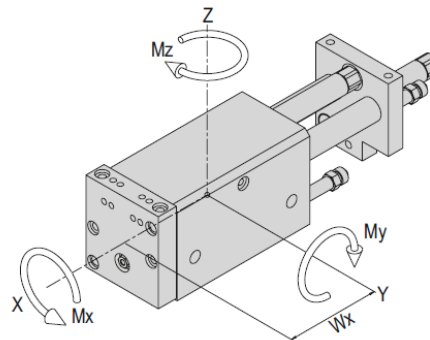

Maximale Nutzlast/Typ	LM 25/60	LM 25/120	LM 25/200
Einbaulage horizontal bei Anbauseite 1	9 kg	6 kg	4 kg
Einbaulage horizontal bei Anbauseite 3	9 kg	6 kg	4 kg
Einbaulage vertikal bei Anbauseite 1	9 kg	6 kg	4 kg
Einbaulage vertikal bei Anbauseite 3	9 kg	6 kg	4 kg

Anbauseiten Moduleinbau horizontal:

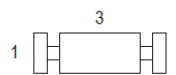

vertikal:

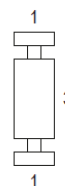

Verfahrzeit-Diagramme

Hubzeit LM 25 mit Stoßdämpfer

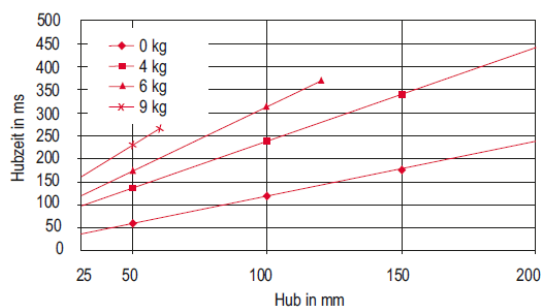

4 Transport, packaging and storage

4.1 Safety instructions for transport



The linear module is a fine mechanical unit and must be handled with the necessary care and cleanliness during transport and storage as well as when handling, setting up and assembling!

CAUTION



Risk of injury when unpacking the module!

The linear modules are packed in the original packaging (cardboard box). If handled incorrectly, the module may fall out of the box when unpacked and cause limb injuries.

- Carefully unpack the linear modules.

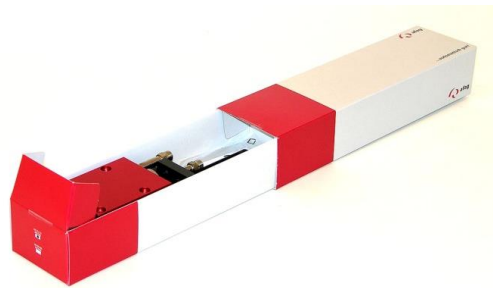

LM 20

Crushing hazard

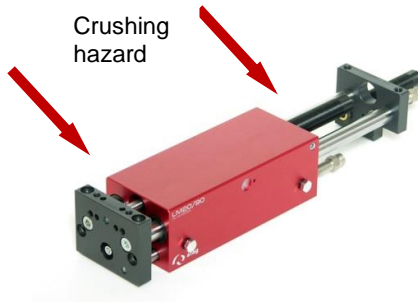

LM 25

Danger of crushing

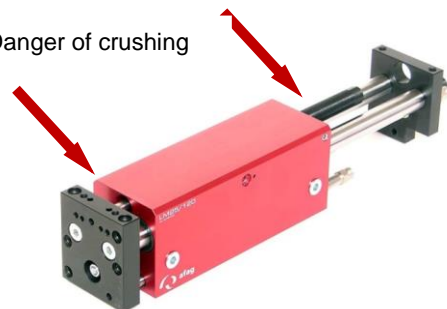

Fig. 3 Linear modules in original packaging and unpacked



Also observe the safety instructions in ↻ chap. 2 „Safety instructions“ in this manual.

4.2 Scope of supply



The scope of delivery of the modules includes assembly and operating instructions as well as a safety information sheet.

The assembly and safety information sheet must be read by every person who carries out work with and on modules!

[Unt]	LM 20 and LM 25
1 x	Linear module
2 x	Stop screws AS 08/40
2 x	Shock absorber SD M14x1-1
2 x	Centering bushing \varnothing 9x4 mm
1 x	Installation instructions

Variants of the linear modules:

The linear module is designed in such a way that it can be installed in any position with the available Afag modules (Fig. 4).

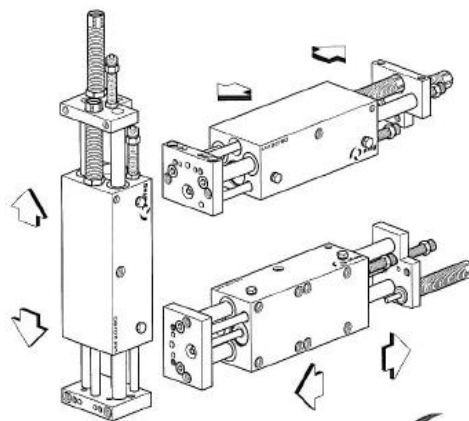

Fig. 4 Linear module (example illustration)

4.3 Transport



No liability can be assumed for damages caused by improper installation on the part of the operating company.



The following conditions must be complied with for transport and storage:

- Storage temperature: 0-50 °C.
- Relative air humidity: < 90%, non condensing.

4.4 Packaging

The linear module is transported in the Afag Automation packaging. If no Afag packaging is used, the linear module must be packed in such a way that it is protected against shocks and dust.

NOTICE

Risk to the environment due to incorrect disposal of the packaging material!

Environmental damage can be caused by incorrect disposal of the packaging material.

- Dispose of the packaging material in an environmentally sensitive way in accordance with the local environmental regulations.
-

4.5 Storage

If the linear module is stored for an extended period, observe the following:

- Store the module in the transport packaging.
- Do not store the telescope spindle axes outdoors or expose them to weather conditions.
- The storage space must be dry and dust free.
- Room temperature of the storage space: 0-50 °C.
- Relative air humidity: < 90% non condensing.
- Clean the module and protect the blank metal parts against corrosion using the appropriate means.
- Protect the linear module from dirt and dust.

5 Design and description

5.1 Structure linear module

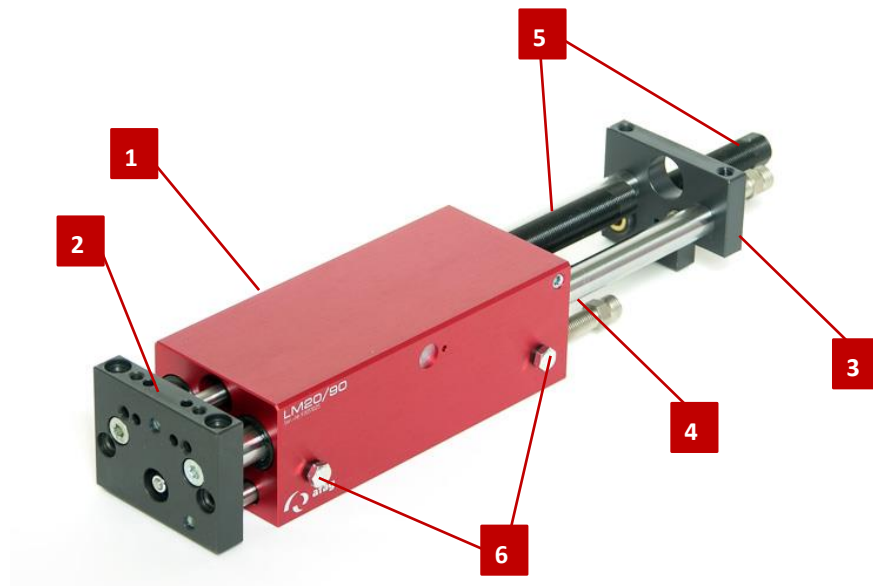

Fig. 5 Design of linear module (exemplary illustration)

- | | |
|----------------|--|
| 1. Base body | 4. Stop screw |
| 2. Front plate | 5. Shock absorber |
| 3. Rear plate | 6. Air connections LM 20=M5, LM 25=G1/8" |

The linear module consists of the base body (Fig. 5, 1) with connections (Fig. 5, 6), a cylinder, a movable front plate (Fig. 5, 2) and rear plate (Fig. 5, 3). The end positions are adjusted via a stop screw (Fig. 5, 4).

5.2 Product description

The linear modules are pneumatically operated devices for linear movements from 0 to 200 mm stroke. All modules are delivered ready for installation in accordance to the customer's order.

A double-acting piston driven by compressed air generates the longitudinal movement. Two guide shafts in the housing with bearing bushes lubricated for life connect the front and rear plates.

For sensing the end positions, the stop screw can be equipped with a holder and a proximity switch (6.5 mm) (not included in the scope of delivery → chap. 5.3 accessories). The movement into end positions is damped by a hydraulic shock absorber (Fig. 5, 5).

5.3 Accessories

5.3.1 Accessories LM 20

Cr.	Designation	Order Number
1	Base plate	➔ Technical catalogue
2	3. Position	➔ Technical catalogue
6	Intermediate stop	➔ Technical catalogue
7	Initiator INI d6.5x44-Sn1.5-PNP-NO-M8x1	11005439
8	Initiator INI 8x8x38.5-Sn2.0-PNP-NO-M8x1	50338170
9	Base plate for intermediate position	➔ Technical catalogue

5.3.2 Accessories LM 25

Cr.	Designation	Order Number
1	Base plate	➔ Technical catalogue
2	Intermediate stop	➔ Technical catalogue
3	Initiator INI d6.5x44-Sn1.5-PNP-NO-M8x1	11005439
4	Initiator INI 8x8x38.5-Sn2.0-PNP-NO-M8x1	50338170

6 Installation, assembly and setting



The system operator is responsible for the installation of the linear module in a system!

When integrating a linear module into an assembly system, the customer must provide an appropriate enclosure or safety barrier.

6.1 Safety Instructions for installation and assembly

The linear module is an incomplete machine.

For safe operation, the linear module must be integrated into the safety concept of the system in which they are installed.

During normal operation, it must be ensured that the user cannot interfere with the working area of the linear module.

CAUTION



Risk of injury when installing the linear module in a system!

Improperly performed work can lead to injuries and damage to property.

- The installation may only be carried out by a qualified specialist!

CAUTION



Risk of injuries due to uncontrolled parts movements!

When operating the linear module uncontrolled movements may occur which cause personal injury or property damage.

- When connecting the compressed air supply for the first time, make sure that all compressed air throttles are closed.
- Vent the system slowly!



No liability for damages can be assumed for damages caused by improper installation/assembling work on the part of the operator.



Also observe the safety instructions in ↻ chap. 2 „Safety instructions“ in this manual.

6.2 Assembly and attachment



The linear modules can be installed in **any** position with the modules of the AFAG range!

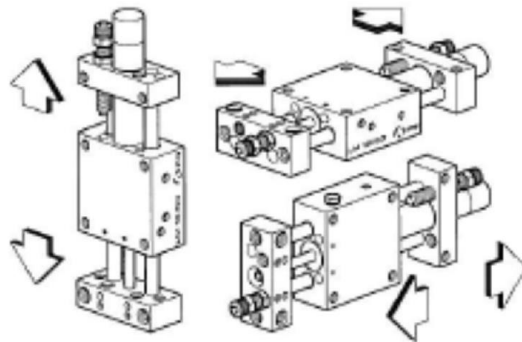

Fig. 6 Linear module (installation in various mounting positions)

6.2.1 Attachment options

Mounting is done on the base body (M6 thread). If the base body is used as a slide, it is attached to the end plates (M6 thread).

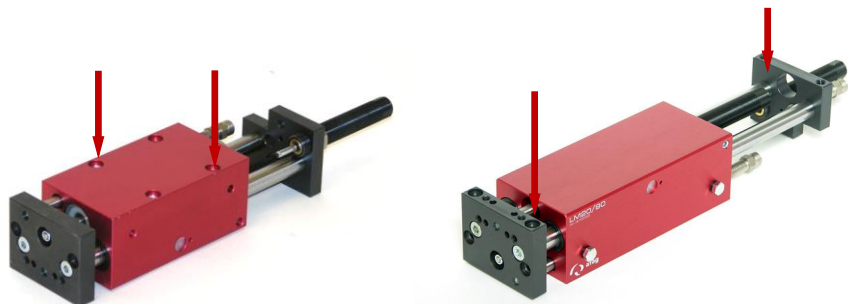

Fig. 7 Fastening options for the linear module

CAUTION



Risk of injury due to sudden movements when installed in vertical position!

When installed in a vertical position, unexpected movements may occur if the slide is not in its lowest position.

- Always move the slide to the lowest position before mounting.



Use the centring bushings included in the scope of delivery for positioning. Insert the centering sleeves into two diagonally lying holes of the attachment grid.

6.2.2 Mounting the modules

The module base body is screwed on from below.

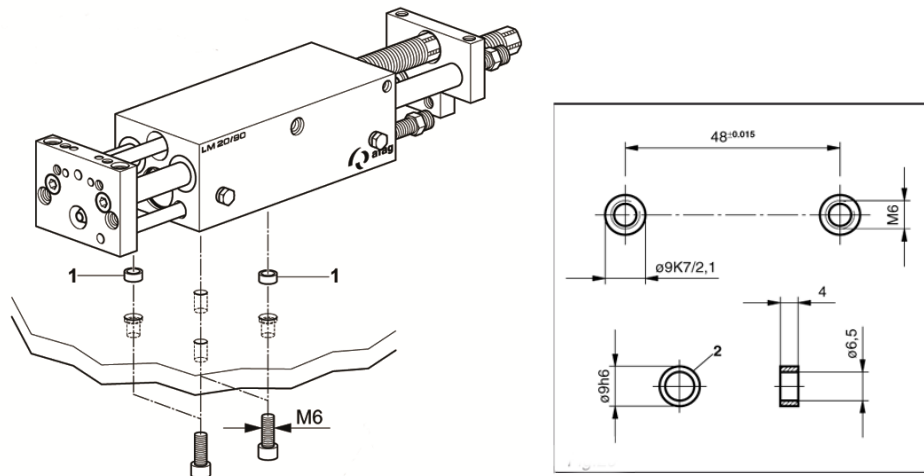

Fig. 8 Mounting base body from below



If the base body is used as a slide, the assembly is carried out on the end plates (M6 thread).

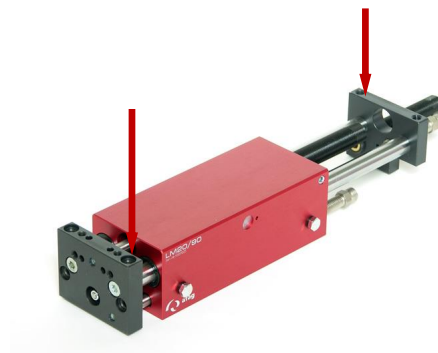

Fig. 9 Linear module - mounting on the end plates (exemplary)

6.2.3 Tightening torques

Use screws with the following minimum specifications for mounting:

Standard	VDI 2230
Strength:	Category 8.8
Surface:	Galvanized blue, oiled or greased

Thread	Tightening torque
M3	1.1 ... 1.3 Nm
M4	2.5 ... 2.9 Nm
M5	4.9 ... 5.8 Nm
M6	8.5 ... 9.9 Nm

6.3 Pneumatic connections

On the base body of the linear module there is 1 pneumatic connection M5 (LM 25) on the right and left side: G 1/8".



The unused pneumatic connections must be sealed airtight with the supplied screw plugs.

Operating pressure: 6 bar +/-2.

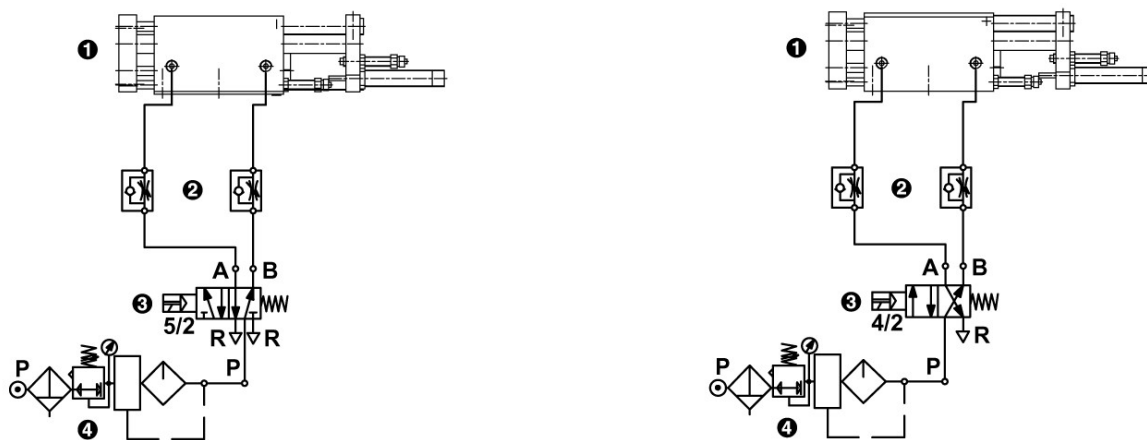

Fig. 10 Pneumatic connection linear module

1. Linear module
2. Throttle valve
3. Directional control valve (standard 5/2)
4. Maintenance unit

Air connection



Minimum compressed air requirements acc. to ISO 8573-1:2010 (7.4.4)!

6.4 Mounting of initiators

WARNING



Risk of explosion!

The initiators must not be used in an explosive environment!

- Only use linear modules and initiators in **non-hazardous** environments!

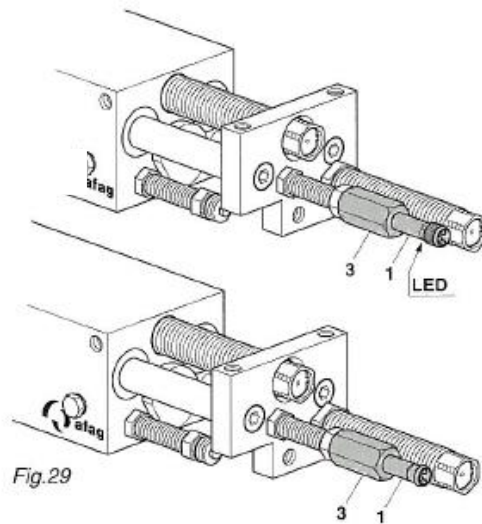

Fig. 29

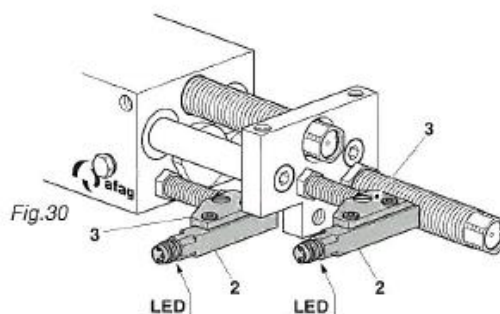

Fig. 30

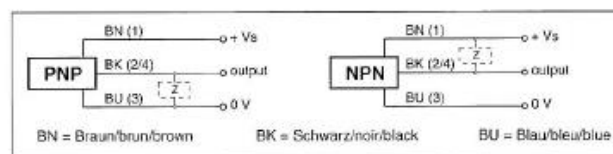

Fig. 31

Fig. 11 Mounting the initiators

Plug-in and screwable D 6.5 mm (Fig. 11, 1) or 8x8 mm (Fig. 11, 2) initiators with holders (Fig. 11, 3) are used for end position detection of the LM.

A LED on the Initiator is used for function monitoring during end position monitoring. If the LED does not change its switching state during end position monitoring, the Initiator is defective and must be replaced! Depending on the controller type, the switching type PNP or NPN of the initiators must be determined.



The 6,5 mm and 8x8 mm proximity switches can only be used with the stop screws of the AS series!

6.4.1 Mounting the initiator 6.5 mm

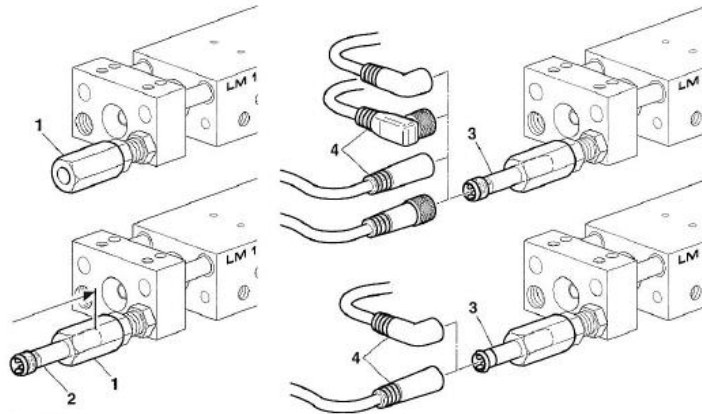

Fig. 12 Mounting initiator 6.5 mm

For assembly the initiator 6.5 mm proceed as proceed:

1. Screw the initiator holder (Fig. 12, 1) onto the stop screw.
2. Insert the initiator (Fig. 12, 2) into the initiator holder as far as it will go.
3. Slightly tighten the initiator holder (Fig. 12, 1).
4. Mount the connector (Fig. 12, 4).
5. Carry out function check.

⇒ The initiator 6.5 mm is mounted.

6.4.2 Mounting initiator 8x8 mm

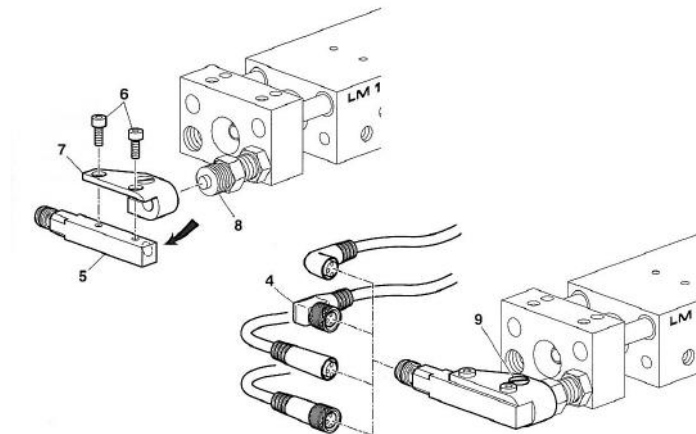

Fig. 13 Mounting initiator 8x8 mm

For assembly the initiator 8x8 mm proceed as proceed:

1. Screw the initiator (Fig. 13, 5) onto the holder (13, 7) with screws (6).
2. Push the holder (7) with initiator onto the stop screw (8) as far as it will go.
3. Clamp with screw (Fig. 13, 9).
4. Mount the connector (Fig. 13, 4).
5. Carry out function check.

⇒ The initiator 8x8 mm is mounted.

6.5 Mounting 3. position

The 3. position, provided there is a height difference "X" between the workpiece holder and the workpiece transfer.

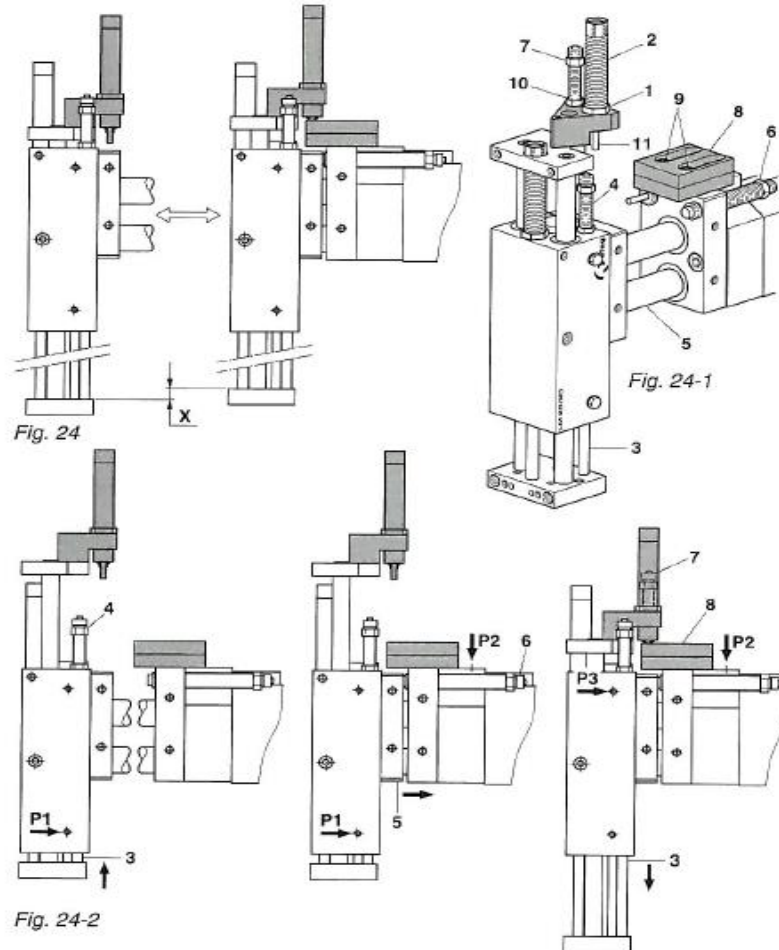

Fig. 14 Mounting of a 3. position (example illustration)

Procedure (example LM 20):

1. Loosen nut (1) and unscrew shock absorber (2) anticlockwise approx. 5 turns (Fig. 24-1).
 2. Apply compressed air at P1. The slide (3) moves upwards until it is limited by the stop screw (4) (Fig. 24-2).
 3. Apply compressed air at P2. The slide (5) moves to the rear position until it is limited by the stop screw (6).
 4. Release compressed air at P1 and apply to P3. The slide (3) moves downwards until it is limited by the stop screw (7) on the plate (8). Adjust the plate (8), if necessary by loosening the screw (9).
 5. Adjust the vertical position of the slide (3) by adjusting the stop screw (7) and then secure it with nut (10).
 6. Screw in the shock absorber (2) clockwise as far as it will go. The shock absorber pin (11) is pressed into the shock absorber.
 7. Now unscrew the shock absorber (2) two turns anticlockwise and secure it with the nut (1). (1 turn = 1 mm).
- ⇒ The 3. position is mounted.

6.6 Attachment intermediate stop

6.6.1 Attachment intermediate stop

The intermediate stop ZA 20/25 is an additional module for the LM 20 / LM 25, which enables a freely selectable intermediate position within the entire stroke range of the linear modules.

Due to the symmetrical design, the intermediate stop can be installed on the base plate ZA, acting both forwards and backwards (Fig. 27).

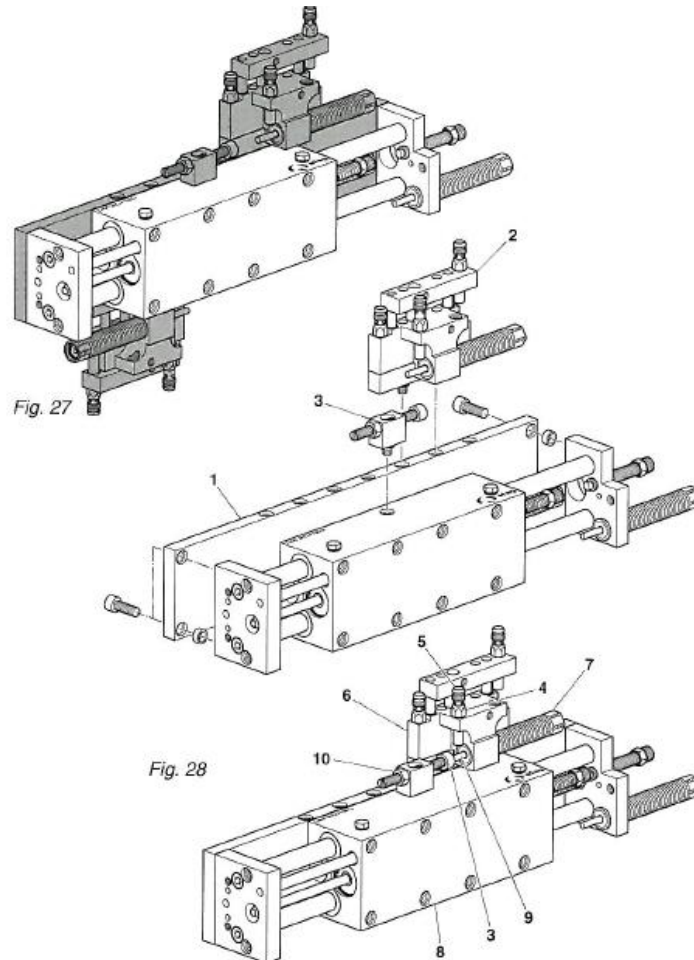

Fig. 15 Attachment of intermediate stop

Set intermediate stop (example: LM 20)

1. Insert base plate (Fig. 15, 1), intermediate stop (Fig. 15, 2) and stop screw (Fig. 15, 3).
2. Release the initiator holder (Fig. 15, 4) and remove the initiator (Fig. 15, 5).
3. Hold the slide (Fig. 15, 6) together with the shock absorber (Fig. 15, 7) in the lower position. Move the housing (Fig. 15, 8) of the LM 20/25 linear guide up to the limit in the direction of the shock absorber (Fig. 15, 7). The shock absorber pin (Fig. 15, 9) is pressed into the shock absorber by the stop screw (Fig. 15, 3).
4. Loosen the nut (Fig. 15, 10) of the stop screw and fix the position by fine adjustment of the stop screw. Then secure the stop screw (Fig. 15, 3) with the nut (Fig. 15, 10).

⇒ The intermediate stop is mounted.

6.6.2 Pneumatic connections intermediate stop (ZA 20/25)



The unused pneumatic connections must be sealed airtight with the supplied screw plugs.

Operating pressure: 6 bar +/-2.

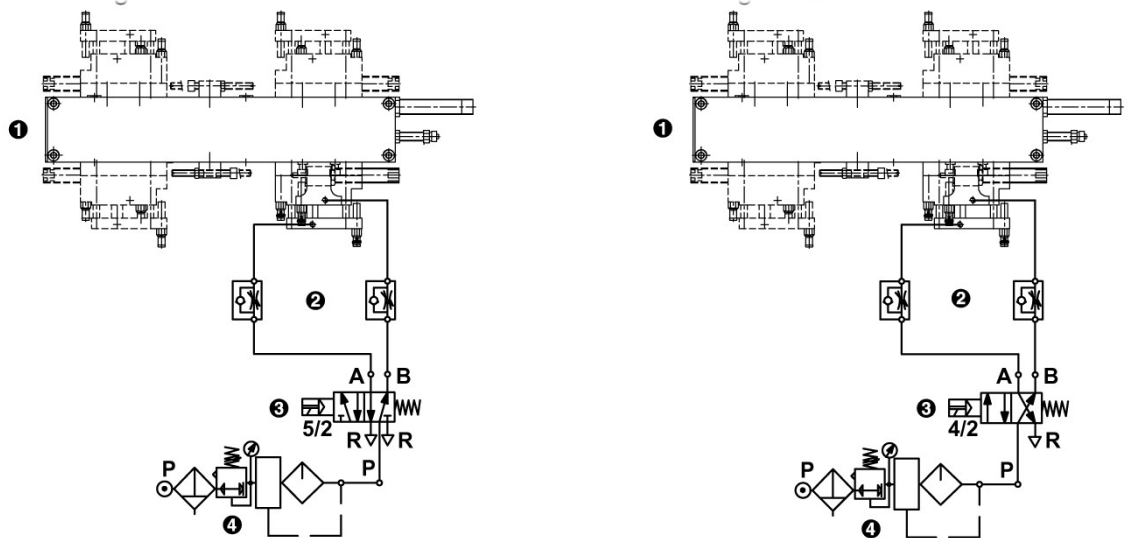

Fig. 16 Pneumatic connection intermediate stop (ZA 20/25)

- 1. Linear module
 - 2. Throttle valve
 - 3. Directional control valve (standard 5/2)
 - 4. Maintenance unit
- Air connection



Minimum compressed air requirements acc. to ISO 8573-1:2010 (7.4.4)!

6.7 Mounting bracket or intermediate plate - LM 25

The connection angle allows the combination of two LM 25.

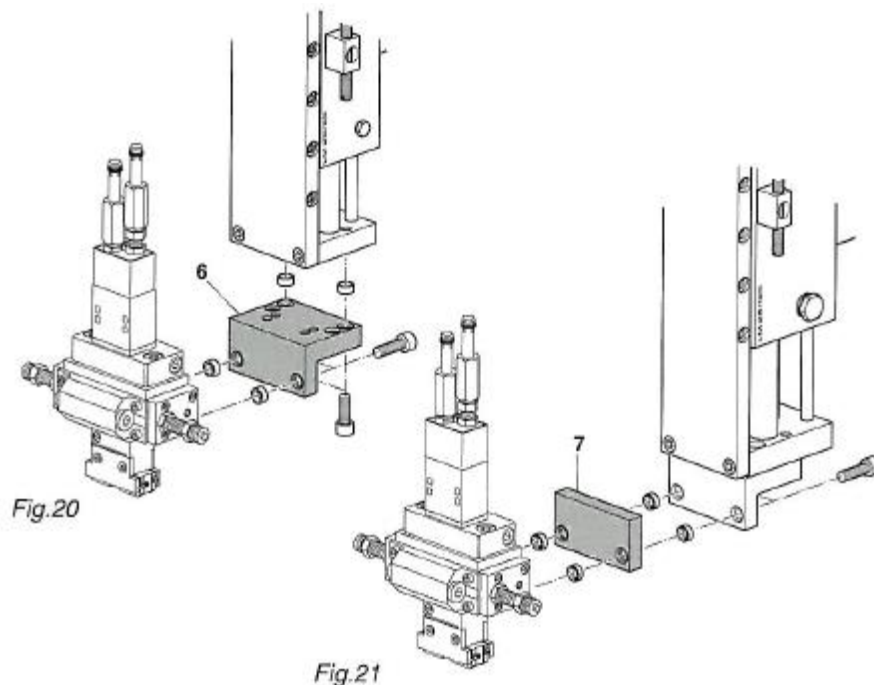

Fig. 17 Attachment of mounting bracket or intermediate plate (LM 25)

The connection plate enables the combination of an LM 20 with a GM 20 module.

Mounting bracket (Fig. 20)

The mounting bracket (6) can be used, for example, to attach an RM 12, RM 16 or RM 25 to the front plate of the LM 20 with the intermediate stop ZA attached.

Intermediate plate (Fig. 21)

The intermediate plate (7) is additionally required if an RM 12, RM 16 or RM 25 is to be attached to the front of an LM 25 with attached ZA.

6.8 Combination of linear modules

The linear modules can be supplied in various versions (Fig. 20).

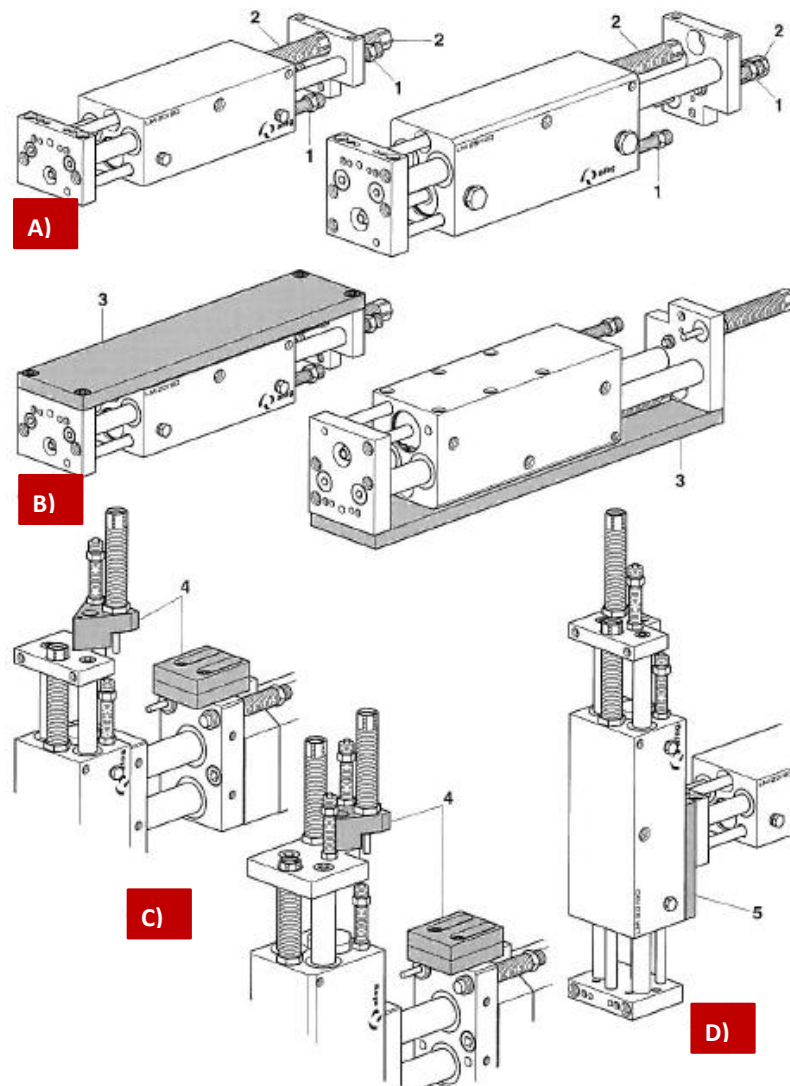

Fig. 18 Combinations with various linear modules

- (A) Linear module LM 20 /25: The standard equipment includes two stop screws AS 08/40 (Fig. 17, 1) and two shock absorbers SD 14/16 (Fig. 20, 2) for end position adjustment.
- (B) Base plate LM 20/25: A stroke module can be realised with the help of the base plate (Fig. 17, 3). The base plate also serves as stabilisation and can be machined by the customer.
- (C) 3. Position LM 20/25: In combination with the LM 32 modules, a simple solution of a 3. Position (Fig. 17, 4) can be realized. This can be used in the entire stroke range of the linear module and the end position is damped and can be acknowledged with an initiator.
- (D) Intermediate plate LM 20: The intermediate plate (Fig. 17, 5) enables an LM 20 to be combined with another LM 20 module.

7 Commissioning

After connection, the modules are put into operation for the first time via the system controller.

7.1 Safety instructions for commissioning

CAUTION



Risk of injuries due to uncontrolled parts movements!

When the control system is switched on, the linear module can make unpredictable movements and cause injury or damage to property.

- Before working on the module, make sure that the controller is switched off and secured against being switched on again.
- Connect or disconnect the cables only when the control is switched off.
- Ensure that there are no persons/tools in the working area!

CAUTION



Risk of injury by reaching into the working area!

During normal operation, it must be ensured that the user cannot interfere with the working area of the linear module.

- The operator can provide suitable protective measures such as enclosures, light barrier or disconnecting the drive from the power supply.

CAUTION



Danger of injury due to missing protective devices!

Operating the linear module without suitable safety devices can lead to considerable damage to property and injuries.

- Protective covers, safety doors or other safety devices must be provided by the user for operation!
- Provide protective devices according to safety guidelines and standards. The presence of persons in the danger zone must be prevented.
- As a matter of principle, the linear module may only be put into operation with closed and functioning protective devices!



Observe the safety instructions in ➔ Chapter 2 „Safety instructions“ of these assembly instructions!

7.2 Preparatory activities for commissioning



Before commissioning, adjust the stroke stop screw and the module absorbers so that the desired stroke is damped correctly.

7.2.1 Adjustment of stroke and stop screws (with stop pin)

The stroke adjustment of the linear module is done by adjusting the stop screws (1 + 2).

These stop screws can be combined with a initiator holder and initiator switch D 6.5 mm or with an angle initiator holder 8x8 mm for end position detection.

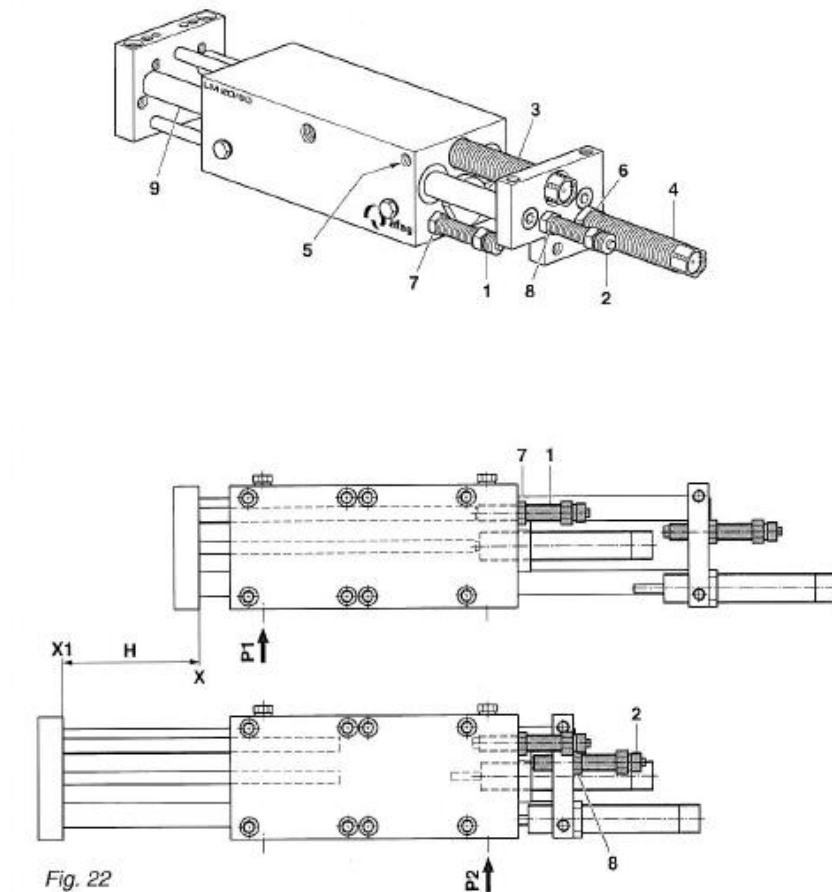

Fig. 19 Stroke adjustment with stop pin

Adjusting the stop screws (example LM 20)

1. Loosen stud bolt (5) or lock nut (6) and unscrew shock absorber (3, 4) approx. 5 turns anticlockwise.
2. Compressed air at P1. The slide (9) of the LM moves onto the stop screw (1).
3. Determine rear position X of stroke H by adjusting stop screw (1), then secure with lock nut (7). (1 turn = 1 mm)
4. Compressed air at P2. The slide (9) of the LM moves onto the stop screw (2).
5. Determine the front position X1 of the stroke by adjusting the stop screw (2), then secure with lock nut (88) (Fig. 22).

⇒ The stroke by means of stop screws is adjusted.

Adjusting the shock absorber

For a smooth stroke movement H, it is braked in the end positions against the stop screws (1+2) by means of Afag shock absorbers (3+4).

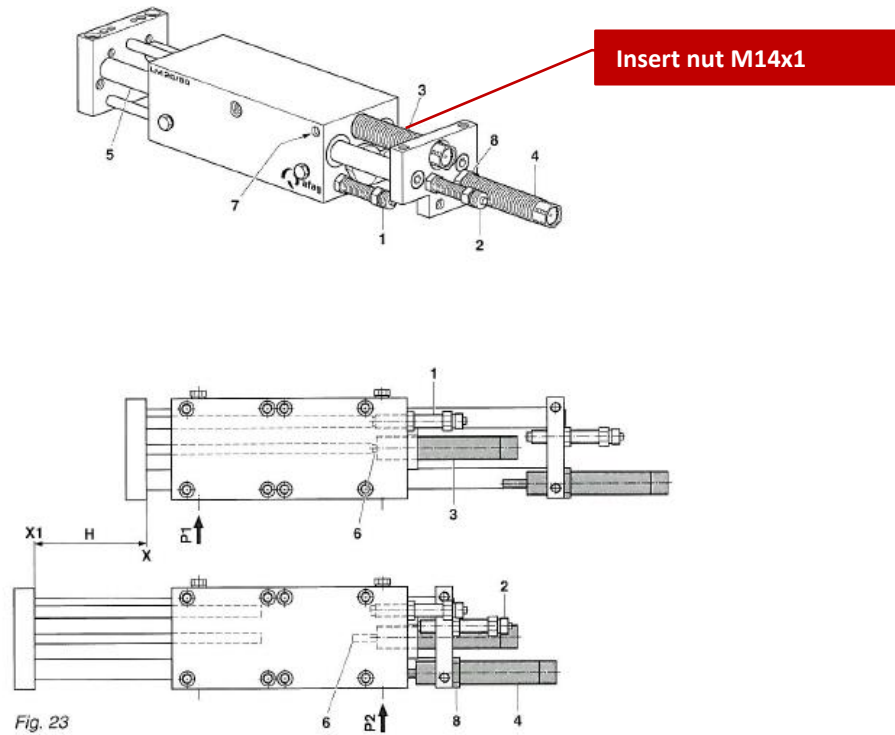

Fig. 20 Stroke adjustment with stop screws

NOTICE

Risk of damage to property!

The shock absorbers must not be used as a stop. They can be damaged.

- Do not use the shock absorbers as stops!

To set the shock absorbers, proceed as follows:

1. Adjust stroke H.
2. Compressed air at P1. The slide (5) of the LM moves to the right until it is limited by the stop screw (1) in position X.
3. Screw in the shock absorber (3) clockwise (the shock absorber pin (6) is pressed into the damper) until the slide (5) moves.
4. Now unscrew the shock absorber (3) two turns anticlockwise and secure it with the stud screw (7)*. (1 turn = 1 mm).
5. Apply compressed air at P2. The slide (5) of the LM moves to the left until it is limited by the stop screw (2) in position X1.
6. Repeat the same procedure as under point 3-4 with shock absorber (4). Then secure the shock absorber with the nut (8).

* From a stroke reduction of 25 mm it is recommended to fix the shock absorber with a nut M14x1 (art. no. 11012242) to avoid jamming of the SD ram.

7.3 Commissioning of the modules

Proceed carefully and follow the instructions step by step when commissioning the modules for the first time:

1. Slowly ventilate the entire system.
 2. Observe permissible values (⇒ chap. 3 Technical data):
 - Payload.
 - Operating pressure.
 - Movement frequency.
 - Load on the guidance system.
 3. Make sure that there are no persons or tools in the working area of the modules.
 4. Perform test run:
 - Start with slow movements.
 - Then continue under normal operating conditions.
- ⇒ Commissioning is completed.

8 Fault elimination

8.1 Safety instructions for troubleshooting



WARNING

Danger of injury due to faulty troubleshooting!

Poorly performed troubleshooting work can lead to serious injuries and damage to property.

- Only use trained specialist personnel for troubleshooting.
- All work on the module must be carried out with the power supply cut off!

NOTICE

Danger of material damage due to vibrations on the drive!

Risk of damage to the linear module and attached components if the moving part of the module oscillates very strongly after switching on the controller (strong vibrations at the drive).

- Switch off the linear module immediately!



Also observe the safety instructions in  chap. 2 „Safety instructions“ in this manual.

8.2 Fault causes and remedy

Fault	Possible cause	Remedy:
Module does not retract or extend	<ul style="list-style-type: none"> ▪ No compressed air ▪ Module incorrectly connected 	<ul style="list-style-type: none"> ▪ Check connections ▪ Check connections
End position no signal	<ul style="list-style-type: none"> ▪ Limit stop screw incorrectly adjusted ▪ Initiator defect ▪ Cable break in sensor cable 	<ul style="list-style-type: none"> ▪ Correct the setting of the stop screw ▪ Replace initiator ▪ Replace proximity switch cable
Module hits the end positions	<ul style="list-style-type: none"> ▪ Shock absorber incorrectly adjusted ▪ Shock absorber defective ▪ No shock absorber available ▪ Exhaust flow control defective ▪ Lifting speed too high 	<ul style="list-style-type: none"> ▪ Readjust shock absorber ▪ Replace shock absorber ▪ Retrofitting of shock absorber ▪ Replace exhaust air throttle ▪ Adjust exhaust flow control
Payload swings in the end position	<ul style="list-style-type: none"> ▪ Lifting speed too high ▪ Suboptimal damping ▪ Unfavourable installation position ▪ Unfavourable type 	<ul style="list-style-type: none"> ▪ Adjust exhaust flow control ▪ Optimise damper type, stroke ▪ Adaptation of the construction ▪ Use larger type

Note: Defective components must be replaced excl. by original spare parts.

9 Maintenance and repair

9.1 General notes

The following maintenance activities can ensure optimum operating condition of the linear modules.

9.2 Safety instructions for Maintenance and Repair

WARNING



Danger of injury due to improper maintenance!

Improperly carried out maintenance activities can cause considerable damage to property and serious injury.

- Only use trained specialist personnel to carry out the activities.
 - Always wear personal protective equipment when carrying out maintenance and repair work!
-

CAUTION



Risk of injury from pneumatics!

When operating the modules uncontrolled movements may occur which cause personal injury or property damage.

- Only work on the linear module when the system is vented and deactivated!
-



Also observe the safety instructions in ➔ chap. 2 „Safety instructions“ in this manual.

9.3 Maintenance activities and maintenance intervals

9.3.1 Overview of the maintenance points



Observe the specified maintenance and care intervals. The intervals apply to normal operating conditions and are to be shortened accordingly for other conditions.

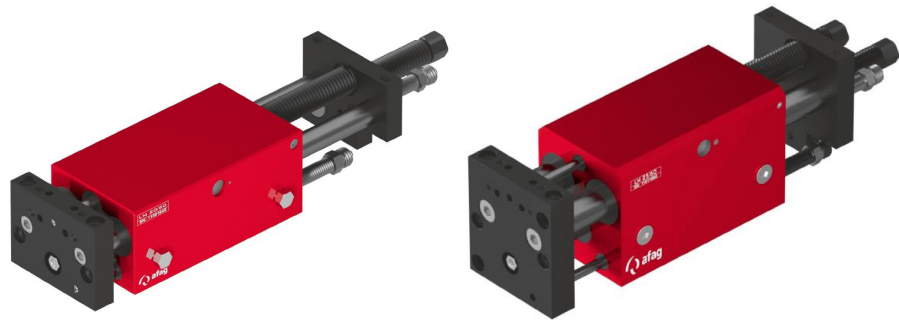





Fig. 21 Maintenance on linear module LM 20 or LM 25

No.	Maintenance point	Maintenance work	Interval	System [On/Off]	Remarks
1	Shock absorber and stop screws	check 	Regularly	[Off]	- <ul style="list-style-type: none">Check function and replace if necessary.Replacing after max. 5 Million load cycles is recommend
2	Linear module	Cleaning 	As required	[Off]	In particular observe cleanliness of measuring tape <ul style="list-style-type: none">With lint-free, dry clothDo not spray module with water, do not use aggressive cleaning agents.
3	Guides and piston rods	Clean and lubricate 	monthly	[Off]	Only when used in an ionized air environment! Afag - standard: - Staburax NBU8EP (flat guides) - Blasolube 301 (piston rods)

9.3.2 Further maintenance

Further maintenance is not required, if the ambient conditions listed below are complied with:

- Clean working area
- No use of splash water
- No abrasive or process dust and vapours
- Environmental conditions as specified in the technical data

9.3.3 Compressed air specification

The modules are lifetime lubricated and can be operated with lubricated or non-lubricated compressed air.

Compressed air specification
Dry (condensation-free)
Filtered (40 µm filter for oil-lubricated air)
Filtered (5 µm filter for oil-lubricated air)

If the modules are operated with lubricated compressed air, we recommend that you use the following types of oil:

oil type	
Festo Special Oil	Shell Tellus Oel C 10
Avia Avilub RSL 10	Mobil DTE 21
BP Energol HPL 10	Blaser Blasol 154
Esso Spinesso 10	

Oil quantity: 5-10 drops of oil per 1000 ltr. Compressed air

Viscosity range: 9 to 11 mm²/s (= cST) at 40°C, ISO class VG 10 according to ISO 3448.

NOTICE

Risk of damage to property!

The operation of the modules with oil-lubricated compressed air causes the factory primary lubrication to be washed out. Therefore, it is absolutely essential that the modules continue to be operated with oil-lubricated compressed air in order to avoid damage to the modules.

- Once the modules have been operated with oil-lubricated compressed air, they **may never** be operated without oil-lubricated compressed air.

NOTICE

Material damage due to incorrectly adjusted, defective or missing shock absorbers!

Incorrectly adjusted, missing or defective shock absorbers impair the function of the module and can lead to its destruction!

- Always operate the linear module with shock absorbers.
- Check shock absorbers for correct adjustment and function!

NOTICE

Risk of corrosion!

When used in ionised air environments (e.g., high voltage processors/corona ionisation), the modules may corrode.

- Regularly coat open flanges/shafts as well as guides and tongs with lubricant.
- We recommend monthly cleaning and lubrication according to Afag standard:
 - Staburax NBU8EP (flat guides)
 - Blasolube 301 (piston rod)

9.4 Spare parts and repair

Afag Automation AG offers a reliable repair service. Defective modules can be sent to Afag for repair within the warranty period.

After expiry of the warranty period, the customer may replace or repair defective modules or wear parts himself or send them to the Afag repair service.

CAUTION



Danger of injury when dismantling the linear module!

If pneumatic connections are disconnected under pressure, sudden rapid movements of moving parts can cause serious injuries!

- Only remove the modules when the system is vented and deactivated!



Damaged linear module may only be replaced or repaired by Afag!

Please note that AFAGF does not assume any warranty for modules that have not been replaced or repaired by AFAG!

9.4.1 Spare and wear parts (LM 20 and LM 25)

After expiry of the official warranty, wearing parts can also be replaced by the customer himself with the help of the corresponding wearing parts set (➔ chap. 9.4.1, chap. 0 "Wearing parts set").

When replacing the wearing parts, all wearing parts should be replaced together and properly so that the functional parts are not damaged.

Depending on the module stroke, the wear part sets are different. Make sure that the correct set of wearing parts is ordered and fitted!



Other defective components will be replaced exclusively by Afag AG.

The instructions for replacing the wearing parts are given without guarantee, as Afag uses special assembly aids for the replacement.

9.4.2 Replace wear parts

Wear parts set LM 20:

Mod. types	LM 20/30	LM 20/60	LM 20/90	LM 20/120	LM 20/150	LM 20/200
Order no.	11002502	11002502	11002502	11002502	11002502	11002502

Wear parts set LM 25:

Mod. types	LM 25/60	LM 25/120	LM 25/200
Order no.	11011243	11011243	11011243

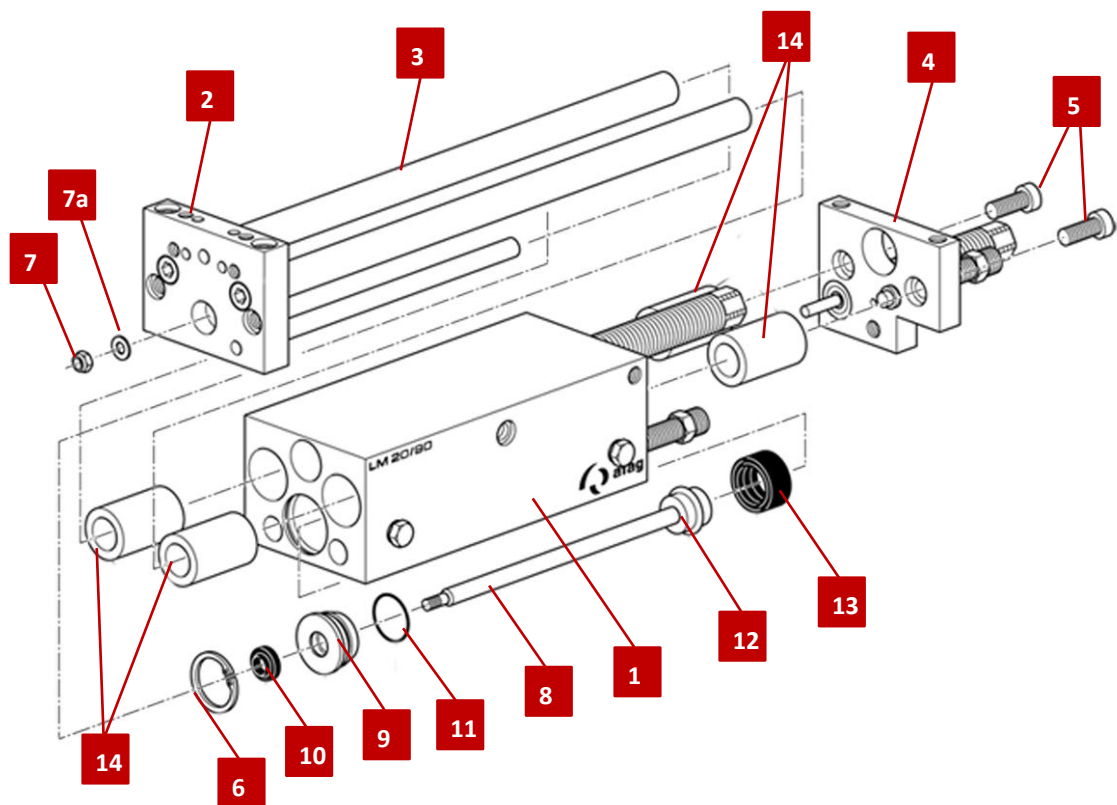

Fig. 22 Replacing wear parts (example)

- | | | |
|-----------------------|-------------------|-------------------|
| 1. Base body | 6. Retaining ring | 10. Wiper |
| 2. Mounting plate | 7a. Washer | 11. O-ring |
| 3. Guide rods | 7b. Stop nut | 12. Piston |
| 4. Stop support plate | 8. Piston rod | 13. Piston seal |
| 5. Screws | 9. Cylinder cover | 14. Ball bushings |



Special assembly aids are used for repairs by Afag technicians. Therefore, the following information (without special tools) only serves as an orientation for assembly or disassembly!

A) Dismounting:

1. Loosen the screws (5) on the stop support plate (4).
 2. Remove the retainer ring (6) from the front of the main body (1).
 3. Extend the mounting plate (2) with guide rods (3) and piston rod (8).
 4. Loosen piston rod stop nut (7b) - hold piston rod (8) with aluminium jaw pliers - then remove piston rod.
 5. Remove the pressure spring (9) with the O-ring (11) and the wiper (10).
 6. Press out piston rod (8) from piston(12) on hand press.
 7. Eject the ball bushings from the base body (1) on a hand press.
 8. Clean the guides on the main body.
 9. Clean the piston rod (8).
 10. Clean the guide rods (3).
- ⇒ The wear parts are dismantled.

B) Assembly:

1. Lubricate ball bush (14) with lubricant "Blasolube 301".
 2. Press the ball bush into the base body (Fig. 21, 1) from two sides.
Important: Wipers of the ball bushings (14) must always be on the outside!
 3. Carefully press the piston rod (8) flush into the pre-assembled piston (12).
 4. Wiper (10), O-ring (11) and cylinder cover are already pre-assembled. Place these pre-assembled parts in the correct position (wiper facing the thread) on the piston rod (8).
 5. Lubricate cylinder cover (9) and O-ring (lubricant: Blasolube 301).
 6. Insert the pre-assembled and lubricated piston rod (8) into the piston bore on the main body (1).
 7. Insert mounting plate (2) with guide rods (3) into ball bushings in the base body (1).
 8. Insert the stop support plate (4) onto the guide rods (3) and tighten with screws (5) (8.5 to 9.9 Nm).
 9. Insert the piston rod (8) into the end plate (2).
 10. Insert washer (7a) on piston rod (8) and tighten with piston rod stop nut (2 Nm). Make sure that the piston rod is held in place with the aluminium jaw pliers.
- ⇒ The wear parts are mounted.

Carry out a function check before installing the module!

1. Push the base body (1) back and forth on the guide rods. Provided the base body can be moved without much resistance, the module is ready for use again.
 2. Carry out a leak test with compressed air!
- ⇒ The function check has been carried out.

10 Decommissioning, disassembly, disposal

The linear modules must be properly dismantled after use and disposed of in an environmentally friendly manner.

10.1 Safety instructions

WARNING



Risk of injury due to improper decommissioning, disassembly and disposal!

Improperly carried out activities can result in considerable material damage and serious injury.

- Only use trained specialist personnel to carry out the activities.
- Disconnect the media supply (pneumatics) before removing the modules!
- Only remove module when the controller is switched off and secured!



Also observe the safety instructions in ➔ chap. 2 „Safety instructions“ in this manual.

10.2 Decommissioning

If the linear modules are not used for a longer period, they must be properly commissioned and stored as described in ➔ chapter 4.5.

10.3 Disposal

The module must be disposed of properly at the end of their service life and the raw materials used must be recycled. Observe the legal regulations and company requirements.

The linear modules must not be disposed of as a complete unit. Dismantle the linear module and separate the various components according to type of material and dispose of them properly:

- Scrap the metallic materials.
- Hand over plastic parts for recycling.
- Sort the rest of the components by their material properties and dispose of them accordingly.

NOTICE

Risk to the environment due to incorrect disposal of the packaging material of the module!

Environmental damage can be caused by improper disposal of the modules.

- Electronic parts, electrical scrap, auxiliary and operating materials must be disposed of by approved specialist companies.
- Information on proper disposal can be obtained from the responsible local authorities.

11 Declaration of incorporation

Declaration of incorporation

for partly completed machinery according to the Machinery Directive 2006/42/EC, Annex II, 1.B

The manufacturer hereby declares:

Afag Automation AG, Luzernstrasse 32, CH-6144 Zell

that the partly completed machine:

Product description	Linear module LM 20, LM 25
Type:	LM 20/30, LM 20/60, LM 20/90, LM 20/120, LM 20/150, LM 20/200, LM 25/60, LM 25/120, LM 25/200

complies with the following essential health and safety requirements of the Machinery Directive 2006/42/EC at the time of declaration: 1.1; 1.1.1; 1.1.2; 1.2.3; 1.3.3; 1.3.5; 1.3.6; 1.3.7; 1.3.9; 1.4.1; 1.5; 1.6; 1.6.1; 1.6.3; 1.6.4; 1.7; 1.7.4; 1.7.4.1; 1.7.4.2.

Harmonised standards applied, in particular:

EN ISO 12100:2010	Safety of machinery - General design principles - Risk assessment and risk reduction.
-------------------	---

Note: The partly completed machinery must not be put into service until the machinery into which it is to be incorporated has been declared in conformity with the provisions of Machinery Directive 2006/42/EC.

The manufacturer undertakes to transmit, in response to a reasoned request by the national authorities, relevant technical documentation for the partly completed machinery.

The relevant technical documentation was created according to Annex VII, Part B of the above-mentioned Directive .

Authorised representative for compiling the technical documentation:

Niklaus Röthlisberger, Product Manager, Afag Automation AG, CH-6144 Zell

Zell, 31.05.2023

Adrian Fuchser



CEO Afag Gruppe

Klaus Bott



CTO Afag Gruppe

Afag Automation AG
Luzernstrasse 32
6144 Zell
Switzerland
T +41 62 959 86 86
sales@afag.com

Afag GmbH
Wernher-von-Braun-Straße 1
92224 Amberg
Germany
T +49 9621 650 27-0
sales@afag.com

Afag Engineering GmbH
Gewerbestraße 11
78739 Hardt
Germany
T +49 7422 560 03-0
sales@afag.com

Afag Automation Americas
Schaeff Machinery & Services LLC.
883 Seven Oaks Blvd, Suite 800
Smyrna, TN 37167
USA
T +1 615 730 7515
nashville@afag.com

Afag Automation APAC
Afag Automation Technology (Shanghai) Co., Ltd.
Room 102, 1/F, Bldg. 56, City Of Elite
No.1000, Jinhai Road, Pudong New District
Shanghai, 201206
China
T +86 021 5895 8065
shanghai@afag.com