

## Operating & Installation Instructions

# Bowl feeder

WV401-1 / WV402-1



### Translation of the Original Assembly Instructions EN

- |                    |               |                       |
|--------------------|---------------|-----------------------|
| ■ WV 401-1 (Right) | 230 V / 50 Hz | ⇒ Order no.: 50177366 |
| ■ WV 401-1 (Left)  | 230 V / 50 Hz | ⇒ Order no.: 50177365 |
| ■ WV 401-1 (Right) | 115 V / 60 Hz | ⇒ Order no.: 50177373 |
| ■ WV 401-1 (Left)  | 115 V / 60 Hz | ⇒ Order no.: 50177372 |
| ■ WV 402-1 (Right) | 230 V / 50 Hz | ⇒ Order no.: 50103719 |
| ■ WV 402-1 (Left)  | 230 V / 50 Hz | ⇒ Order no.: 50103718 |
| ■ WV 402-1 (Right) | 115 V / 60 Hz | ⇒ Order no.: 50177371 |
| ■ WV 402-1 (Left)  | 115 V / 60 Hz | ⇒ Order no.: 50177368 |

### Dear Customer

Thank you for choosing our products and placing your trust and confidence in our company!

These operating and installation instructions contain all essential information you need about your product. Our aim is to provide the required information as concisely and clearly as possible. If, however, you still have any questions on the contents or suggestions, please do not hesitate to contact us. We are always grateful for any feedback.

Our team will also be glad to answer any further question you may have regarding the bowl feeder or other options.

We wish you every success with our products!

With kind regards

*Your Afag team*

### © Subject to modifications

The bowl feeders have been designed by Afag Automation AG according to the state of the art. Due to the constant technical development and improvement of our products, we reserve the right to make technical changes at any time.

### Updates of our documentations



Unlike the printed documents, our digital instructions manuals, product data sheets and catalogues are being continuously updated on our website.

Please keep in mind that the digital documents on our website are always the latest versions.

### © Copyright 2023 Afag Automation AG

All contents of the present operating and installation instructions, in particular the texts, photographs, and graphics, are protected by copyright. All rights reserved. No part of these assembly and operating instructions may be reproduced, distributed (made available to third parties), or transmitted in any form or by any means, including photocopying, recording, or other electronic or mechanical methods, without the prior written permission of Afag Automation AG.



**Afag Automation AG**  
**Werner-von-Braun Street 1**  
**D-92224 Amberg (Germany)**  
Tel.: +49 (0) 9621 65 027-0  
e-mail: sales@afag.com  
Internet: www.afag.com

**Afag Automation AG**  
**Luzernstrasse 32**  
**CH-6144 Zell (Switzerland)**  
Tel.: +41 62 959 86 86  
e-mail: sales@afag.com  
Internet: www.afag.com

## Table of contents

<b>1</b>	<b>General</b> .....	<b>5</b>
1.1	Contents and purpose of this manual.....	5
1.2	Explanation of symbols.....	5
1.3	Additional symbols.....	6
1.4	Warranty .....	7
1.5	Liability.....	7
<b>2</b>	<b>Safety instructions</b> .....	<b>8</b>
2.1	General .....	8
2.2	Intended use.....	8
2.3	Foreseeable misuse .....	9
2.4	Obligations of the operator and the personnel .....	9
2.4.1	Follow these instructions.....	9
2.4.2	Obligations of the operating company.....	9
2.4.3	Obligations of the personnel .....	10
2.5	Personnel requirements .....	10
2.5.1	Personnel qualification .....	10
2.6	Personal protective equipment (PPE).....	11
2.7	Changes and modifications .....	11
2.8	General hazards / residual risks.....	11
2.8.1	General hazards at the workplace .....	11
2.8.2	Danger due to electricity .....	12
2.8.3	Mechanical hazards .....	12
2.8.4	Danger due to alternating magnetic fields .....	13
2.8.5	Noise hazards .....	13
<b>3</b>	<b>Technical data</b> .....	<b>14</b>
3.1	Dimensional drawing WV401-1 / WV 402-1 .....	14
3.2	Technical data WV401-1 / WV 402-1 .....	15
3.3	Accessories .....	16
3.3.1	Mounting parts.....	16
3.3.2	Adjustment aids.....	16
3.3.3	Controller.....	16
<b>4</b>	<b>Transport, packaging and storage</b> .....	<b>17</b>
4.1	Safety instructions .....	17
4.2	Scope of supply .....	17
4.3	Transport .....	18
4.4	Packaging.....	18
4.5	Storage .....	18
<b>5</b>	<b>Design and description</b> .....	<b>19</b>
5.1	Structure of the WV401-1 – WV402-1.....	19

5.2	Description of the bowl feeder WV .....	20
<b>6</b>	<b>Installation, assembly and setting .....</b>	<b>21</b>
6.1	Safety instructions .....	21
6.2	Assembly .....	22
6.2.1	Tightening torques.....	22
6.2.2	Definition of the feed direction.....	22
6.2.3	Fixingbowl feeder .....	23
6.2.4	Mount the feeding bowl .....	24
6.3	Electrical connection.....	26
<b>7</b>	<b>Operation .....</b>	<b>27</b>
7.1	Safety instructions for commissioning .....	27
7.2	Preparatory activities for commissioning.....	27
7.2.1	Notes on the control unit used .....	27
7.2.2	Notes for trouble-free feeding .....	28
7.3	First commissioning.....	28
<b>8</b>	<b>Fault elimination.....</b>	<b>29</b>
8.1	Safety instructions .....	29
8.2	Fault causes and remedy .....	29
<b>9</b>	<b>Maintenance and repair.....</b>	<b>30</b>
9.1	General notes .....	30
9.2	Safety instructions .....	30
9.3	Maintenance activities and maintenance intervals.....	31
9.3.1	Overview of the maintenance points .....	31
9.3.2	Notes on cleaning.....	32
9.3.3	Remove or replace leaf springs .....	33
9.4	Settings.....	34
9.4.1	Set magnetic gap .....	34
9.5	Adjustment of the oscillation system .....	35
9.6	Further maintenance .....	36
9.7	Spare and wear parts, repairs .....	36
9.7.1	Spare parts.....	36
9.7.2	Wear parts.....	36
<b>10</b>	<b>Decommissioning and disposal .....</b>	<b>37</b>
10.1	Safety instructions .....	37
10.2	Decommissioning .....	37
10.3	Disposal.....	37

## 1 General

### 1.1 Contents and purpose of this manual

These operating and installation instructions contain important information on assembly, commissioning, functioning and maintenance of the bowl feeder WV to ensure safe and efficient handling and operation.

Consistent compliance with these operating instructions will ensure:

- permanent operational reliability of the bowl feeders,
- optimal functioning of the bowl feeders,
- timely detection and elimination of defects (thereby reducing maintenance and repair costs),
- prolongation of the bowl feeders service life.

The illustrations in this manual shall provide you with a basic understanding of the module and may vary from the actual design of your module.

### 1.2 Explanation of symbols

The safety notes are marked by a pictogram and a signal word. The safety notes describe the extent of the hazard.

#### DANGER

---



#### **Danger!**

This safety note indicates an imminently hazardous situation which, if not avoided, will result in death or serious injury.

---

#### WARNING

---



#### **Warning!**

This safety note points out a potentially hazardous situation which, if not avoided, could result in death or serious injury.

---

#### CAUTION

---



#### **Caution!**

This safety note points out a potentially dangerous situation which, if not avoided, can result in minor or slight injuries.

---

#### NOTICE

---

This safety note points out a potentially dangerous situation which, if not avoided, can cause substantial damage to property and the environment.



---



This note contains important additional information as well as useful tips for safe, efficient, and trouble-free operation of the bowl feeders.

**Further warning signs:**

Where applicable, the following standardised symbols are used in this manual to point out the various potential health risks.

	Warning - Dangerous electrical voltage.
	Warning - Risk of hand and finger injury due to uncontrolled movements of components.
	Warning - Magnetic field

**1.3 Additional symbols**

In these assembly instructions the following symbols are used to highlight instructions, results, references, etc.

Symbol	Description
1.	Instructions (steps ...)
⇒	Results of actions
↻	References to sections
■	Enumerations not ordered

### 1.4 Warranty

The warranty terms for Afag handling components and handling systems are the following:

- 24 months from initial operation and up to a maximum of 27 months from delivery.
- Wear parts are excluded from the warranty (The customer is entitled to a product free of defects. *This does also apply to defective accessories and wear parts. Normal wear and tear are excluded from the warranty.*)

The warranty covers the replacement or repair of defective Afag parts. Further claims are excluded.

**The warranty shall expire in the following cases:**

- Improper use of the handling system.
- Non-observance of the instructions regarding installation, commissioning, operation and maintenance.
- Improper assembly, commissioning, operation and maintenance.
- Repairs and design changes carried out without prior technical instructions of Afag Automation AG.
- Removing the serial number from the product.
- Non-observance of the EC Machinery Directive, the Accident Prevention Regulations, the Standards of the German Electrotechnology Association (VDE) and these safety and assembly instructions.

### 1.5 Liability

No changes shall be made to the bowl feeders unless described in this manual or approved in writing by Afag.

Afag accepts no liability for unauthorized changes or improper assembly, installation, commissioning, operation, maintenance or repair work.

## 2 Safety instructions

### 2.1 General

This chapter provides an overview of all important safety aspects to ensure safe and proper use of the bowl feeders and optimal protection of personnel.

Safe handling and trouble-free operation of the bowl feeder requires knowledge of the basic safety regulations.

Every person carrying out installation, commissioning, maintenance work or operating the bowl feeder must have read and understood the complete user manual, especially the chapter on safety instructions.

Beyond this, there are rules and regulations regarding accident prevention that are applicable to the place of installation which must be observed.



Failure to follow the directions and safety instructions given in this instructions manual may result in serious hazards.

---

### 2.2 Intended use

The Afag bowl feeders WV are exclusively designed for storing, conveying, separating and sorting workpieces of different dimensions, design forms and material variants.

The following uses of the WV are considered as **improper use** :

- Use in damp and wet areas
- Use at temperatures below 10°C or above 45°C
- Use in areas with highly flammable media
- Use in areas with explosive media
- Use in heavily polluted or dusty environments
- Use in aggressive environment (e.g., salty atmosphere)



The intended use of the module also includes:

- observance of all instructions given in this manual.
  - compliance with the inspection and maintenance work and the specifications in the data sheets,
  - using only original spare parts.
-



### 2.3 Foreseeable misuse

Any use other than or beyond the intended use described above is considered a misuse of the bowl feeder WV.

#### WARNING



**Risk of injury if the bowl feeder WV is not used for its intended use or if it is foreseeable used incorrectly!**

The improper use of the bowl feeder WV poses a potential hazard to the personnel.

- The bowl feeders may only be used in a technically perfect condition in accordance with its intended use and the instructions in this manual as well as in compliance with the safety requirements!

### 2.4 Obligations of the operator and the personnel

#### 2.4.1 Follow these instructions

A basic prerequisite for safe and proper handling of the bowl feeders is a good knowledge of the basic safety instructions.



This manual, in particular the safety instructions contained therein, must be observed by all persons working with the bowl feeder.

#### 2.4.2 Obligations of the operating company

In addition to the safety instructions given in this manual, the operating company must comply with the safety accident prevention and environmental protection regulations valid for the field of application of the bowl feeder.

The operating company is required to use only personnel who :

- have the necessary professional qualifications and experience,
- are familiar with the basic rules regarding occupational safety and accident prevention,
- have been instructed in the correct handling of the bowl feeder,
- have read and understood these operating instructions.

**The operating company is also required to:**

- monitor on an ongoing basis that the personnel work safely considering any potential hazard involved and the assembly instructions are observed,
- ensure that the assembly instructions are always kept at hand at the installation in which the bowl feeder is mounted,
- observe and communicate universally applicable laws and regulations regarding accident prevention and environmental protection,
- provide the necessary personal protective equipment (e.g., protective gloves) and instruct the personnel to wear it.

### 2.4.3 Obligations of the personnel

All personnel working with the modules are required to:

- read and observe these assembly instructions, especially the chapter on safety,
- observe the occupational safety and accident prevention regulations,
- observe all safety and warning signs on the modules,
- refrain from any activity that might compromise safety and health.



In addition, the personnel must wear the personal protective equipment required for carrying out their work (➔chap. 2.6).

## 2.5 Personnel requirements

### 2.5.1 Personnel qualification

The activities described in the assembly instructions require specific requisites at the level of professional qualifications of the personnel.

Personnel not having the required qualification will not be able to assess the risks that may arise from the use of the bowl feeder thus exposing himself and others to the risk of serious injury. Therefore, only qualified personnel may be permitted to carry out the described activities on the bowl feeder.

These operating instructions are intended for skilled personnel (installers, system integrators, maintenance personnel, technicians), electricians and operating personnel.

The following is a description of the professional skills (qualifications) required for carrying out the different activities:

#### Qualified personnel:

Qualified personnel with appropriate training who are qualified due to their special know-how and fully familiar with the machine and who have been given instructions on how to carry out the task entrusted to them safely.

#### Qualified electrician:

Persons who have obtained their electrical qualifications through appropriate professional training and complementary courses that enables them to identify risks and prevent possible hazards resulting from electricity.

#### Operator (trained personnel):

Authorized persons who due to their specialized professional training, expertise and experience can identify risks and preventing possible hazards arising from the use of the machine.

### 2.6 Personal protective equipment (PPE)

The personal protective equipment serves to protect the personnel from hazards affecting their safety and health at work.

When working on/with the bowl feeder, the personnel must use the protective equipment assigned by the safety officer of the operating company or as required by safety regulations. In addition, the personnel are required to:

- wear the personal protective equipment provided by the operating company (employer),
- check the personal protective equipment for proper condition, and
- immediately notify the person responsible on site of any defects found on the personal protective equipment.

### 2.7 Changes and modifications

No changes may be made to the WV which have not been described in these operating instructions or approved in writing Afag Automation AG.

Exceptions to this are the processes described in ↻chap. 6.2.4 "Assembly of the bowl" and ↻chap. 9.5 "Device-specific adjustment".

Afag Automation AG accepts no liability for unauthorised changes or improper assembly, installation, commissioning, maintenance or repair work.



The bowl feeders may not be changed or modified in any way, except with the prior written consent of Afag.

---

### 2.8 General hazards / residual risks

Despite the safe design of the WV and the technical protective measures taken, there still remain residual risks that cannot be avoided, and which present a non-obvious residual risk when operating the rotary modules.

Observe the safety instructions in this chapter and in the other sections of this manual to avoid damage to property and dangerous situations for the personnel.

#### 2.8.1 General hazards at the workplace

The bowl feeder WV has been built according to the state-of-the-art and the applicable health and safety requirements. However, improper use of the bowl feeder may cause the following hazards to the personnel:

- danger to life and limb of the operator or third parties,
- on the modules themselves,
- property damage.



Always keep the operating instructions ready at hand at the workplace!  
Please, also observe:

- the general and local regulations on accident prevention and environmental protection,
- the safety information sheet for the bowl feeder.

### WARNING



#### **Danger - Do not use in unsuitable environment !**

The WV are designed for use in **non**-explosive atmospheres.

- Do **not** use the WV feeders in potentially explosive atmospheres!

### CAUTION



#### **Risk of injuries due to uncontrolled parts movements!**

When operating the WV uncontrolled movements may occur which can cause personal injury or property damage.

- Only qualified personnel may work with or on the WV.
- Read this manual carefully before carrying out any work on or with the WV.

## 2.8.2 Danger due to electricity

### WARNING



#### **Danger! Risk of electric shock!**

If work on electrical components is required, ensure that the work is carried out properly, failure to do so will cause serious or fatal injuries.

- Work on the machine's electrical equipment may only be performed by skilled electrician or trained personnel under the supervision of a skilled electrician in accordance with all relevant electrical regulations.

## 2.8.3 Mechanical hazards

### CAUTION



#### **Danger of injury by moving components!**

Limbs can be crushed by moving components!

- Work on and with the WV may only be carried out by qualified personnel.
- Never reach into the system during normal operation!

### 2.8.4 Danger due to alternating magnetic fields



#### **DANGER**

##### **Danger due to alternating magnetic fields!**

The alternating magnetic fields occurring in the immediate vicinity of the HLF can affect the proper functioning of e.g., pacemakers and defibrillators.

- Persons with a pacemaker must keep a safe distance from WV (**15 cm outside the WV** and **20 cm above the WV**) (distance implant to field source).
- 

### 2.8.5 Noise hazards



#### **CAUTION**

##### **Noise hazards!**

In certain cases, an impermissible noise level may result (e.g., when opening the lid of the noise protection hood for filling or refilling the parts).

- Wear hearing protection during noise-critical activities!
-

### 3 Technical data

#### 3.1 Dimensional drawing WV401-1 / WV 402-1

Type	WV401-1	WV402-1
A1	440 mm	440 mm
A2	419 mm	419 mm
A3	300 mm	300 mm
D1	8 x 9 mm	8 x 9 mm
D2	4 x 8H7	4 x 8H7
D3	3 x M10	3 x M10
D4	12 x M6	12 x M6
D5	6 x M8	6 x M8
E1	400 mm	400 mm
E2	360 mm	360 mm
E3	350 mm	350 mm
E4	320 mm	320 mm
H	243 mm	243 mm
K	12.5 mm	12.5 mm
L	5 mm	5 mm
M	25 mm	25 mm
X1	15 °	15 °
X2	15 °	15 °
X3	30 °	30 °

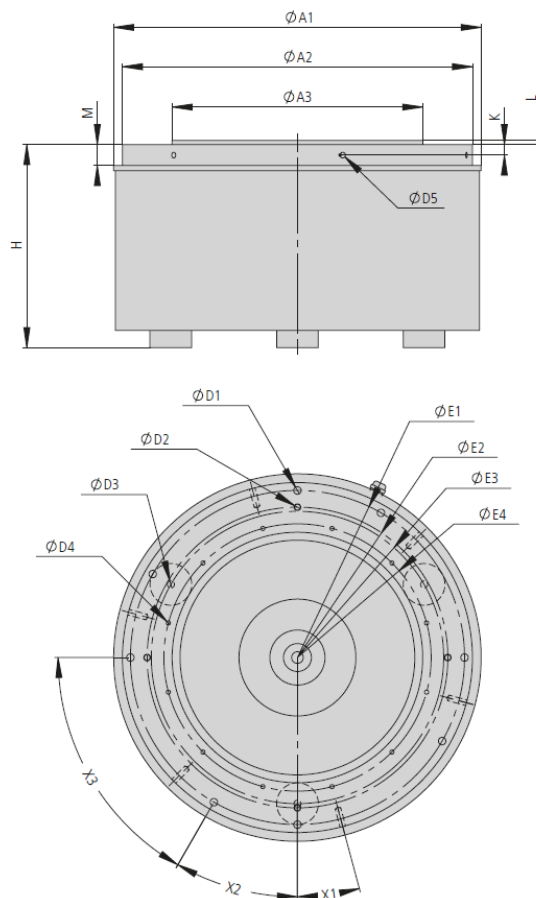

Fig. 1 Dimensional drawing - WV401-1 / WV402-1

**3.2 Technical data WV401-1 / WV 402-1**

WV401				
Operating temperature	10 - 45 °C			
Type	WV401-1	WV401-1	WV401-1	WV401-1
<b>Order number</b>	<b>50177366</b>	<b>50177365</b>	<b>50177373</b>	<b>50177372</b>
Mechanical vibration frequency	50 Hz	50 Hz	60 Hz	60 Hz
Mains connection (mains voltage/mains frequency)	230 V/50 Hz	230 V/50 Hz	115 V/60 Hz	115 V/60 Hz
Max. power consumption	1260 VA	1260 VA	1260 VA	1260 VA
Net weight	100.7 kg	100.5 kg	100.9 kg	100.8 kg
Admissible bowl weight $\pm 30\%$	30 kg	30 kg	30 kg	30 kg
Angle of the gradient of the leaf springs	15 °	15 °	15 °	15 °
Delivery direction	right	left	right	left
Protection type	IP54	IP54	IP54	IP54
Type	WV402-1	WV402-1	WV402-1	WV402-1
<b>Order number</b>	<b>50103719</b>	<b>50103718</b>	<b>50177371</b>	<b>50177368</b>
Mechanical vibration frequency	100 Hz	100 Hz	120 Hz	120 Hz
Mains connection (mains voltage/mains frequency)	230 V/50 Hz	230 V/50 Hz	115 V/60 Hz	115 V/60 Hz
Max. power consumption	1128 VA	1128 VA	1128 VA	1128 VA
Net weight	101 kg	101 kg	101.3 kg	101.3 kg
Admissible bowl weight $\pm 30\%$	30 kg	30 kg	30 kg	30 kg
Angle of the gradient of the leaf springs	15 °	15 °	15 °	15 °
Delivery direction	right	left	right	left
Protection type	IP54	IP54	IP54	IP54

**Included in delivery**

- 4x Leaf spring WV
- 8x Spacers WV

### 3.3 Accessories

#### 3.3.1 Mounting parts

Designation	Type	Order Number
Centring angle	-	50197375
Spacers	5mm	50021483
	10mm	50021486
	20mm	50021484

#### 3.3.2 Adjustment aids

Designation	Drive type	Order Number
Distance gauges	WV 401-1	50201935
	WV 402-1	50201938

#### 3.3.3 Controller

Type	Power supply	Order Number	Note
IRG1-S	230V/50Hz	50360105	Control without timer function
	-	-	External setpoint setting
MSG801	230V/50Hz - 115V/60Hz	50391818	Sensor feed, timer function, valve and interface outputs
MSG802	230V/50Hz - 115V/60Hz	50391819	Sensor feed



For more information on the controller, see ➔ chap. 6.3 and the controller manufacturer's instructions.



## 4 Transport, packaging and storage

### 4.1 Safety instructions



#### CAUTION

##### **Danger of injury due to improper transport equipment!**

The improper use of transport equipment such as industrial trucks, overhead cranes, slings) can lead to injuries (e.g., crushing)!

- Observe transport and assembly instructions.
- Use the means of transport properly!

#### NOTICE

##### **Damage to property due to improper lifting!**

The bowl feeder must not be lifted by the feed bowl or the arrangement elements! This can damage the bowl feeder!

- Lift the bowl feeder only at the base plate using suitable lifting equipment!
- Attach the lifting device to the threaded hole of the base plate.



The bowl feeders are packed in the original packaging (cardboard box). Carefully remove the bowl feeder from the original packaging.

### 4.2 Scope of supply



The corresponding documentation is supplied with each bowl feeder (e.g., operating and installation instructions, etc.).

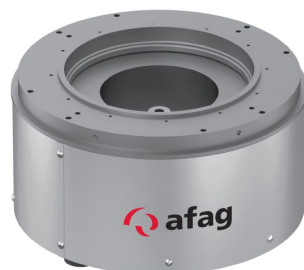

Fig. 2 Scope of delivery WV

[Unt]	Designation
1 x	Bowl feeder WV
1 x	Operating & Installation Instructions

### 4.3 Transport



---

No liability can be assumed for damages caused by improper installation on the part of the operating company.

---



---

The following conditions must be complied with for transport and storage:

- Storage temperature: 0-50 °C
  - Relative air humidity: < 90%, non condensing
- 

### 4.4 Packaging

The bowl feeder is transported in the Afag Automation AG transport packaging. If no Afag packaging is used, the bowl feeder must be packed in such a way that it is protected against shocks and dust.

#### NOTICE

##### **Risk to the environment due to incorrect disposal of the packaging material!**

Environmental damage can be caused by incorrect disposal of the packaging material.

- Dispose of the packaging material in an environmentally sensitive way in accordance with the local environmental regulations.
- 

### 4.5 Storage

If the bowl feeder is stored for an extended period, observe the following:

- Store the bowl feeder in the transport packaging.
- Do not store the telescope spindle axes outdoors or expose them to weather conditions.
- The storage space must be dry and dust free.
- Room temperature of the storage space: 0-50 °C.
- Relative air humidity: < 90% non condensing
- Protect the bowl feeder from dirt and dust.

## 5 Design and description

### 5.1 Structure of the WV401-1 – WV402-1

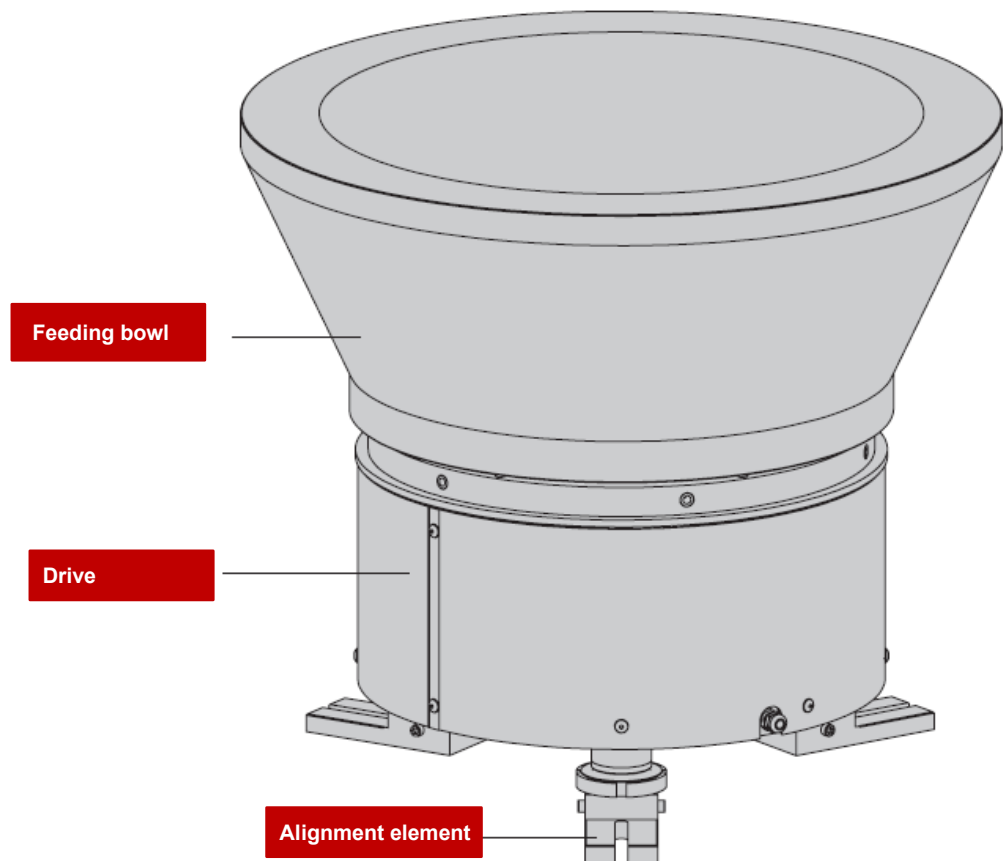

Fig. 3 Structure of the bowl feeder WV401-1/ WV402-1

The WV is a vibratory conveyor that converts electromagnetic vibrations and uses them to transport workpieces.

The WV works by exploiting resonance behaviour, which keeps energy consumption to a minimum.

The bowl feeder WV is used in conjunction with a bowl for storing, transporting, separating and sorting bulk goods.

The transport movement is generated by vibration. Here, the parts are moved in the transport direction by micro-jumps.



The bowl feeders are to be operated in combination with an Afag controller. Only in this combination can optimum conveying behaviour be guaranteed.

## 5.2 Description of the bowl feeder WV

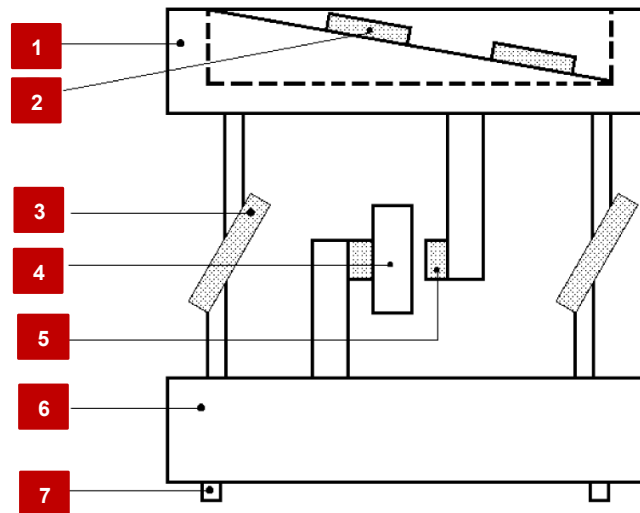

Fig. 4 Bowl feeder basic structure

- |                      |                  |
|----------------------|------------------|
| 1. Feeding bowl      | 5. Anchor        |
| 2. Conveyed material | 6. Counterweight |
| 3. Spring assembly   | 7. Rubber buffer |
| 4. Drive magnet      |                  |

The drive magnet (4) is connected to the counter mass (6) and generates a force that attracts or releases the anchor (5) depending on the oscillation frequency of the power supply.

As the magnetic anchor is connected to the feeding bowl, it also follows the frequenting movement. Due to the angle of inclination of the leaf spring, the conveyed material lifts off the conveyor track with each oscillation and performs small throwing movements (micro throwing) in a perpendicular direction to the leaf spring plane.

The WV performs 100 oscillations per second with an AC mains supply of 50Hz, as the vibrating solenoid attracts the magnetic anchor with both positive and negative current pulses. This 100 Hz oscillation is necessary to achieve a smooth or gentle transport.

However, for heavy or larger workpieces, it is necessary to use a vibration frequency of 50-Hz. A half wave of the mains supply is thereby blocked.

## 6 Installation, assembly and setting

For safe operation, the module must be integrated into the safety concept of the system in which it is installed.

During normal operation, it must be ensured that the user cannot interfere with the working area of the bowl feeder. This can be achieved through suitable protective measures (e.g., enclosure, light grid).

When the system is running in special operating modes, it must be ensured that there is no danger to the operator.



The system operator is responsible for the installation of the bowl feeder in a system!

### 6.1 Safety instructions

#### WARNING



#### Danger! Risk of electric shock!

If work on electrical components is required, ensure that the work is carried out properly, failure to do so will cause serious or fatal injuries.

- Work on the machine's electrical equipment may only be performed by skilled electrician or trained personnel under the supervision of a skilled electrician in accordance with all relevant electrical regulations.
- Disconnect the power supply before assembly and disassembly work and when making changes to the installation!



The noise level can be reduced by using noise protection hoods.



No liability for damages can be assumed for damages caused by improper installation on the part of the operator.



Observe the safety instructions in ↻chap. 2 "Safety instructions" of this manual as well as the instructions in ↻chap. 6.3.

## 6.2 Assembly

### 6.2.1 Tightening torques

Tightening torques  $M_{Sp}$  in [Nm] for shaft bolts with metric ISO standard threads and head rests according to DIN 912 or DIN 931.

Screw	Tightening torques $M_{Sp}$ in [Nm]		
	Strength class 8.8	Strength class 10.9	Strength class 12.9
M4	2.8	4.1	4.8
M5	5.5	8.1	9.5
M6	9.5	14.0	16.5
(M7)	15.5	23.0	27.0
M8	23.0	34.0	40.0
M10	46.0	68.0	79.0
M12	79.0	117.0	135.0
M14	125.0	185.0	215.0
M16	195.0	280.0	330.0
M18	280.0	390.0	460.0
M20	390.0	560.0	650.0
M22	530.0	750.0	880.0
M24	670.0	960.0	1120.0
M27	1000.0	1400.0	1650.0
M30	1350.0	1900.0	2250.0

### 6.2.2 Definition of the feed direction

For the bowl feeder, the feed directions are defined as follows:

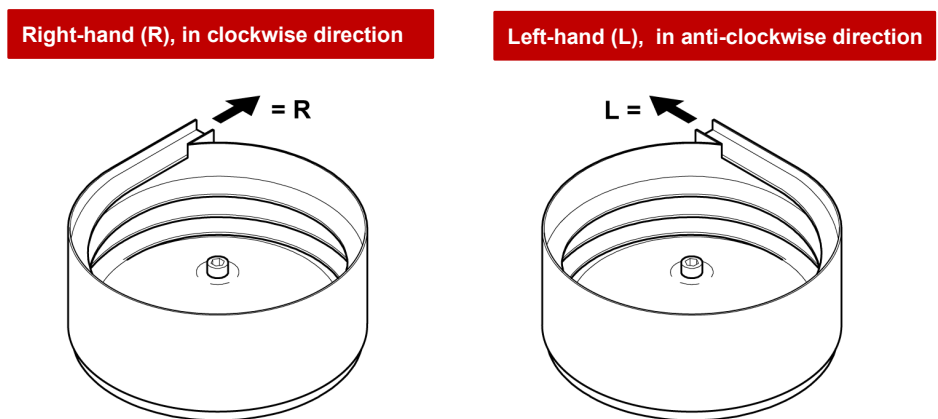

Fig. 5 Defined feed direction

### 6.2.3 Fixingbowl feeder

The bowl feeder must always be mounted on a sufficiently dimensioned substructure (observe dimensions) for operation.

The spiral conveyor can be fixed as follows:

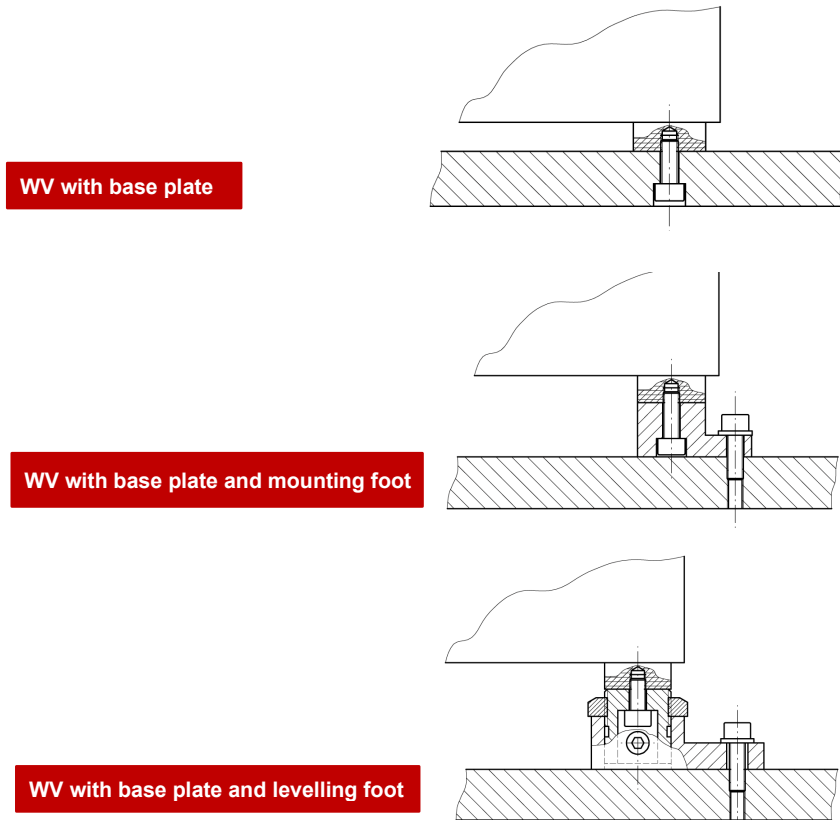

Fig. 6 Fastening of the bowl feeder



When mounting, make sure that the base is horizontal.

### 6.2.4 Mount the feeding bowl



To ensure proper functioning of the WV, the max. permissible mass of the feeding bowl must not be exceeded.

#### Fitting and threaded holes on the drive:

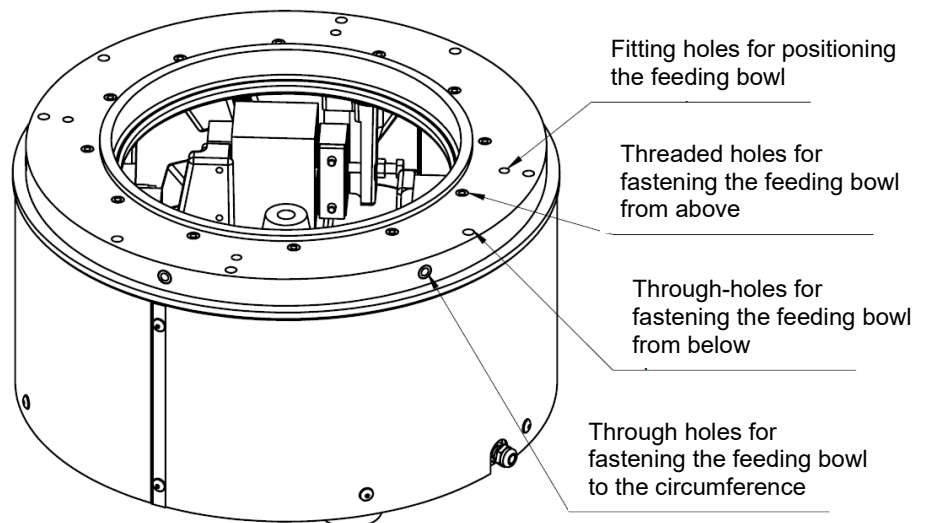

Fig. 7 Fitting and threaded holes for mounting the feeding bowl



Fitting holes are provided on the mounting plate through which the bowl can be precisely positioned on the WV drive.

This eliminates the need to set up the interface on the bowl discharge again when changing the bowl.



Fastening options on the drive:

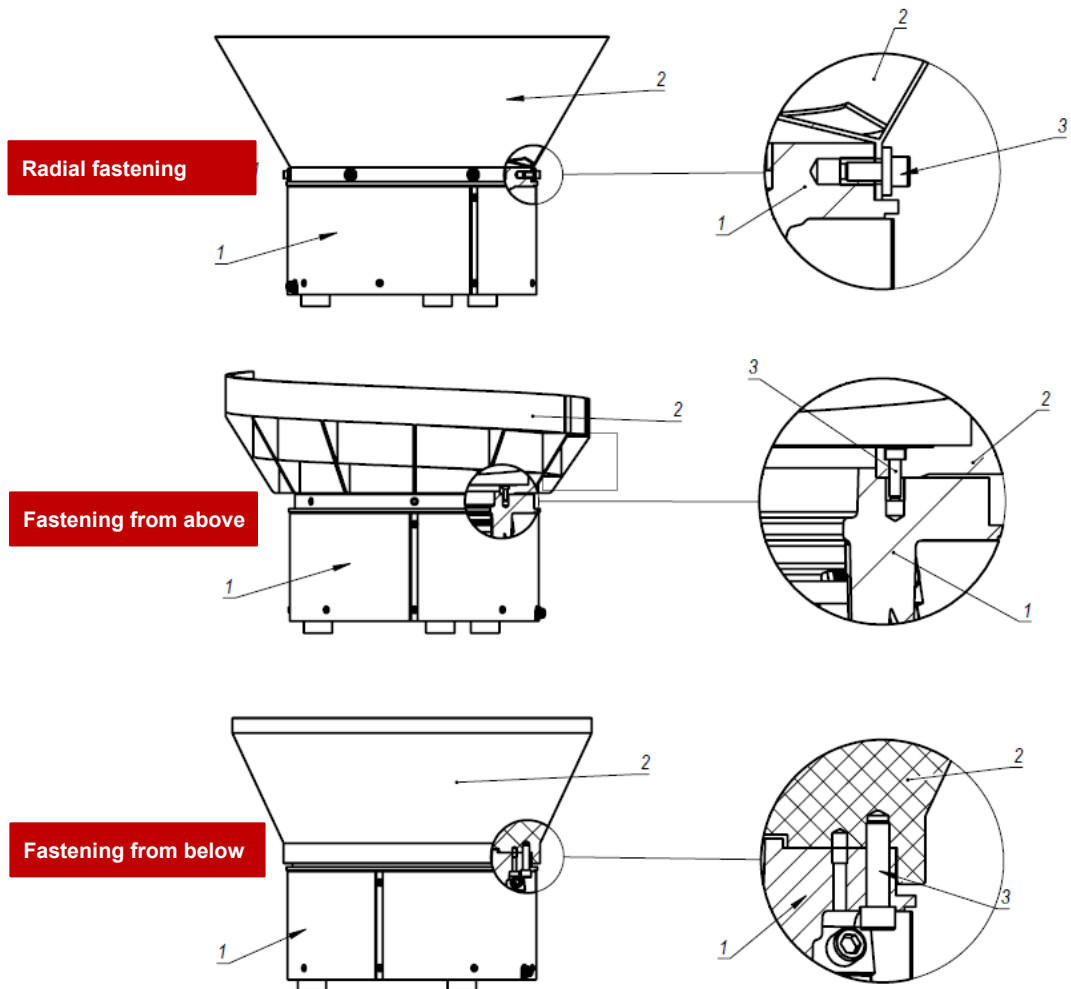

Fig. 8 Bowl attachment: radial, from above and on the circumference

### 6.3 Electrical connection

#### WARNING



#### Danger! Risk of electric shock!

Improperly performed work can result in serious or fatal injuries.

- Work on the machine's electrical equipment may only be performed by skilled electrician or trained personnel under the supervision of a skilled electrician in accordance with all relevant electrical regulations.

#### Important notes on the electrical connection

- The mains supply must be provided by the customer via a residual current circuit breaker!
- The feeder may only be operated with the mains supply specified on the type plate!
- Emergency-STOP devices must remain effective in all operating modes. Unlocking the Emergency-STOP devices must not cause an uncontrolled restart!

#### Power connection via controller

The WV is connected to the AC mains 230 V/50 Hz via a control unit type IRG. The design for other mains voltages and frequencies is possible, e.g. 115V/60Hz.

The IRG1-S controller is available for controlling the WV. The MSG801 or MSG802 can also be used. An additional CEE appliance plug is required for the MSG controls (order numbers no.: 11006982!).

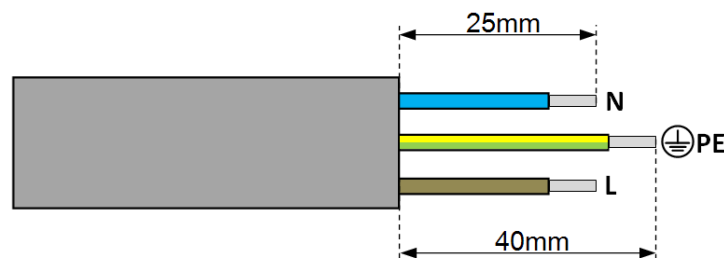

Fig. 9 Cable end additional plug

The bowl feeder operates in full-wave mode at twice the mains frequency, i.e., at 50Hz AC with a mechanical vibration frequency of 100Hz; for half-wave operation with the simple mains frequency, i.e., with 50Hz.

Vibration displacement and thus the transport speeds are infinitely adjustable due to magnet current and thus magnetic force variability. All IRG types operate with soft-starting and offer different options for mounting, attachment and control.



A detailed description of the controller can be found in the Afag general catalogue. Third-party control units can also be used, provided they meet the technical conditions.

## 7 Operation



After the control unit is switched on, no further settings are necessary in normal operation.

Only the refilling of the feed bowl must be ensured for uninterrupted running.

### 7.1 Safety instructions for commissioning

#### CAUTION



##### Noise hazards!

In certain cases, an impermissible noise level may result (e.g., when opening the lid of the noise protection hood for filling or refilling the parts).

- Wear hearing protection during noise-critical activities!

#### NOTICE

##### Material damage due to jamming of the parts!

If the bulk material is not filled into the centre of the feed bowl, the arrangement device can be damaged or the required output can no longer be achieved, as the falling parts can jam in the arrangement device!

- Fill bulk material into the centre of the feed bowl!

### 7.2 Preparatory activities for commissioning

#### 7.2.1 Notes on the control unit used

The bowl feeder is designed for operation with Afag - controllers. The modules can also be operated with other control systems.

The operation of the AFAG controllers is described in the separate installation manual for the respective controllers.

Perform a test run in preparation for commissioning. To turn de connectors, proceed as follows:

1. Connect the controller to the computer (operating software must be installed).
  - The use of the operating software is described in the installation instructions for the controllers used.
2. If the module is supplied with an Afag controller, no further action is required (operating parameters already stored in the controller).
3. When using a different controller, special cables must be made, and the operating parameters determined.
  - ⇒ The test operation can now be carried out.

### 7.2.2 Notes for trouble-free feeding

For trouble-free feeding, the workpieces must fulfil the following conditions:

- Oil, grease and burr-free
- Not sticky
- not statically charged
- non-magnetic (must not have any intrinsic magnetism)
- dirt-free and not mixed with foreign parts
- Rubber parts can be talcumised

### 7.3 First commissioning

Proceed carefully and follow the instructions step by step when commissioning the modules for the first time:

1. Observe the permissible technical values (➔ chap 2.8).
    - Payload, frequency, moment load
  2. First, make sure that there are no persons or tools in the working area.
  3. Perform test run:
    - Start with slow movements,
    - then continue under normal operating conditions.
- ⇒ Commissioning is completed.

# 8 Fault elimination

## 8.1 Safety instructions



Observe the safety instructions in ➔ chap. 2 "Safety instructions" of these installation instructions as well as the safety instructions of the controller manufacturer.

## 8.2 Fault causes and remedy



Faults caused by defective components may only be remedied by replacing these components.

Only Afag original spare and wear parts may be used!

Fault	Possible cause	Remedy:
Bowl feeder does not run after switching on	<ul style="list-style-type: none"> <li>▪ Plug not connected to mains</li> <li>▪ Connecting cable between bowl feeder and control unit not plugged in</li> <li>▪ Set the controller on controller to "0"</li> <li>▪ Fuse in controller defective</li> </ul>	<ul style="list-style-type: none"> <li>▪ Plug in the connector.</li> <li>▪ Plug in the connector.</li> <li>▪ Turn the controller to position.</li> <li>▪ Replace fuse.</li> </ul>
Bowl feeder does not provide the required performance after a certain running time	<ul style="list-style-type: none"> <li>▪ Fastening screws of the spring assemblies have loosened</li> <li>▪ Fixing screw between oscillating plate and bowl has loosened</li> <li>▪ Air gap between solenoid coil and yoke has formed</li> <li>▪ Spring broken</li> <li>▪ Controller on the control unit has been adjusted</li> </ul>	<ul style="list-style-type: none"> <li>▪ Remove the screw fitting and tighten the screw</li> <li>▪ Tighten the screws</li> <li>▪ Remove the housing and readjust the air gap (➔ chap. 9.4.1, )</li> <li>▪ Remove housing and replace broken spring (➔ chap. 9.3.3)</li> <li>▪ Readjust controller</li> </ul>
Bowl feeder generates strong noise	<ul style="list-style-type: none"> <li>▪ Housing has loosened</li> <li>▪ Solenoid coil or yoke have come loose</li> <li>▪ Foreign body between bowl outlet and linear section</li> <li>▪ The air gap between the bowl outlet and the linear path are too small</li> <li>▪ Air gap too small, solenoid coil and yoke touch each other</li> </ul>	<ul style="list-style-type: none"> <li>▪ Tighten the screws of the housing</li> <li>▪ Tighten the screws (➔ chap. 9.4.1)</li> <li>▪ Remove foreign body</li> <li>▪ Loosen the bowl and turn it a little. Then check the transitions between the bowl discharge and the linear section!</li> <li>▪ Adjust the air gap (➔ chap. 9.4.1)</li> </ul>
Bowl feeder does not run in certain ranges of the controller scale	<ul style="list-style-type: none"> <li>▪ Potentiometer defective</li> </ul>	<ul style="list-style-type: none"> <li>▪ Replace potentiometer (➔ Operating instructions of the control unit)</li> </ul>

## 9 Maintenance and repair

### 9.1 General notes

The bowl feeders type WV are practically maintenance-free. Nevertheless, some maintenance work must be carried out to ensure an optimum operating condition of the modules.

### 9.2 Safety instructions

#### DANGER



##### Risk of injury due to electric shock!

There is a risk of electric shock when working on the electrical equipment and when removing the housing!

- Pull out the mains plug before removing the housing!
  - Work on the electrical equipment may only be carried out by trained, authorized personnel!
- 

#### WARNING



##### Danger of injury due to improper maintenance!

Improperly carried out maintenance activities can cause considerable damage to property and serious injury.

- Only use trained specialist personnel to carry out the activities.
  - Always wear personal protective equipment when carrying out maintenance and repair work!
- 

#### WARNING



##### Risk of injuries due to uncontrolled parts movements!

Signals from the controller can trigger unintentional movements of the bowl feeder, which can cause injury.

- Before starting any work on the bowl feeder, switch off the controller and secure to prevent it from being switched on.
  - Observe the operating instructions of the controller used!
- 



Also observe the safety instructions in  chap. 2 „Safety instructions“ in this manual.

---

### 9.3 Maintenance activities and maintenance intervals



The maintenance intervals must be strictly observed. The intervals refer to a normal operating environment.

#### 9.3.1 Overview of the maintenance points

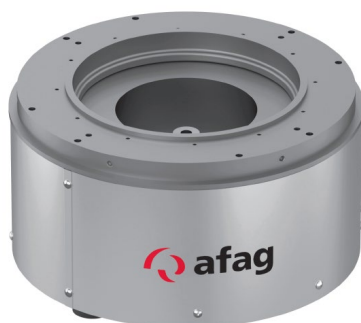





Fig. 10 Maintenance of bowl feeder WV

No.	Maintenance point	Maintenance work	Interval	System [On/Off]	Remarks
1	Leaf spring	Check 	Regularly	[Off]	-  ▪ Leaf springs for heavy soiling
2	Electrical equipment	Check 	Regularly	[Off]	-  ▪ Check for: - Loose connections, scorched or otherwise damaged cables - Replace damaged cables immediately!
3	Feeding bowl	Cleaning 	Regularly	[Off]	-  ▪ Clean the feeding bowl. Observe notes in  chap. 9.3.2!

9.3.2 Notes on cleaning

**NOTICE**

**Risk of material damage if the following instructions are not observed!**

If cleaning agents or cleaning methods other than those listed are used, there is a risk of permanent damage to components and the function of the bowl feeder can no longer be guaranteed.

- Only use the specified cleaning agents!
- It is essential to observe the cleaning methods!

**WARNING**

**Risk of injury from volatile substances!**

The cleaning agents to be used contain volatile substances that can cause irritation or injury to the eyes or respiratory tract.



- Wear safety glasses.
- Ensure sufficient ventilation!

**Cleaning the feeding bowl (according to its coating):**

Bowl coating:	Cleaning agent:	Cleaning method:
Hard anodised / Inox raw or polished	Benzine or spirit	Ultrasonic bath
Metaline	Soapy water	Wash off with a damp cloth, allow to dry
Habasite light green TS10	Hoover	Vacuum cleaning
Polyamide pot raw, Habasit white, dark green Polyurathan red, yellow, grooved Nextel coating	Benzine or spirit	Wipe out with a damp cloth and dry again, cleaning agent must not be poured into the feeding bowl. Feeding bowl must not be immersed in cleaning bath.
Teniferated, blue chromated	Nitro thinner	Dampen a rag with nitro thinner and rub with it
Colour sprayed / painted / powder coated	Soapy water / universal cleaner	Wipe with a damp cloth
PET / Makrolon / Plexi	Hoover and anti-static spray	Vacuum clean before rubbing down, then spray with an anti-static spray and rub off



### 9.3.3 Remove or replace leaf springs

The leaf springs should only be removed and cleaned if they are very dirty. In rare cases, the leaf springs must be completely replaced.



Do not oil or grease leaf springs! This would lead to the springs sticking together and negatively influence the oscillation behaviour

To remove the leaf springs, please proceed as follows:

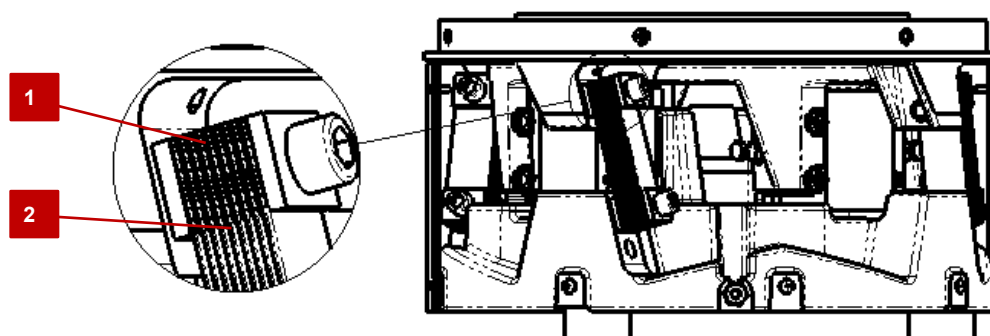

Fig. 11 Spring assembly



When removing the leaf springs, only one spring assembly may be loosened at a time to prevent the mounting plate from sagging or shifting.

1. Pull out the mains plug and remove the cover.
2. Remove the screws of the spring assembly to be replaced.
3. Reassemble the spring assembly.
  - Number of leaf springs (1) and structure of a spring assembly must correspond to the original spring assembly. This is the only way to ensure the function of the module!
4. Fit the spring assembly and tighten the screws (135 Nm).
  - Make sure that the spacers (2) are not twisted.
5. Check air gap between solenoid coil and yoke and readjust if necessary (→chap. 9.4.1).
6. Assemble the housing (1).
7. Perform test run.
  - ⇒ The process is completed.

## 9.4 Settings

### 9.4.1 Set magnetic gap

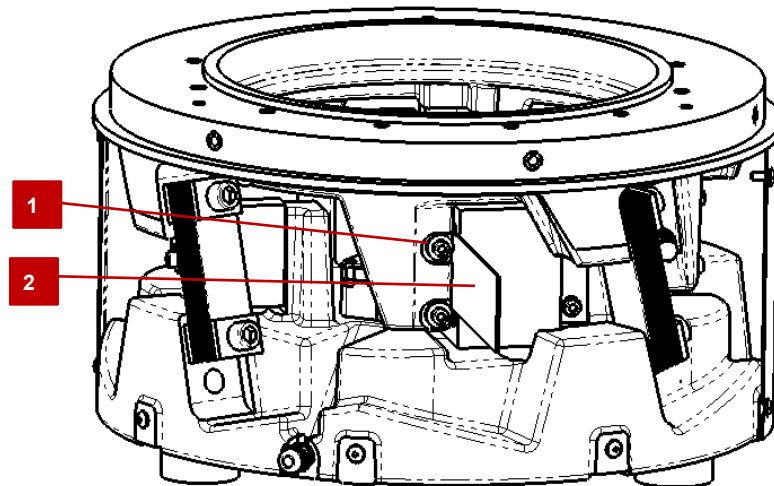

Fig. 12 Magnet gap adjustment with distance gauge

	WV 401-1	WV 402-1
Magnet gap	2.0mm	1.5mm
Tightening torque	9.5 Nm	9.5 Nm

#### To adjust the magnetic gap, proceed as follows:

1. Pull out the mains plug.
2. Remove the cover.
3. Loosen the fastening screws (1) for the magnetic anchor and the adjusting screws.
4. Insert the appropriate distance gauge (2) (→ chap. 3.3.2 Adjustment aids) between the magnetic anchor and the magnet core.
5. Press all magnetic anchors by hand against the spacer gauge and the magnet core and retighten the fastening screws (**9.5 Nm**).
6. Screw the adjusting screws into the magnetic anchors as far as they will go and secure them with hexagon nuts.
  - Make sure that the distance gauges can be easily removed but do not have too much play.
  - Otherwise, the magnetic gap is too large and the adjustment process must be repeated.
7. Refit the cover.
  - ⇒ The process is completed.

## 9.5 Adjustment of the oscillation system

The WV are equipped with a standard spring assembly at the factory. To achieve optimum conveying and sorting behaviour, the WV must be matched to the specific operating conditions. The WV is optimally tuned when the desired delivery speed is reached at a regulator position of 80% and the delivery speed always decreases when the fastening screw is loosened.



To prevent the fastening plate from sagging, only one spring assembly may be released at a time!

### To tune the WV, proceed as follows:

1. Unscrew the cover of the WV.
2. Check bolts for bowl fastening and leaf spring fastening for tightness and retighten if necessary (⇒ chap. 6.2.1).
3. Check the air gap of the magnets (correct if necessary (⇒ chap. 9.4.1)).
4. Switch on the WV and set the controller of the control unit to 80%.
5. Slowly loosen the lower fastening screw on a spring assembly.
  - The conveying speed changes:

### Procedure for decreasing conveying speed:

1. Install additional leaf springs (⇒ chap. 9.3.3).
2. Start with a spring in a spring assembly.
3. If the speed still decreases when the fastening screw is loosened again, remove one spring and intermediate layer at a time from the individual spring assemblies.
4. Distribute the number of leaf springs as evenly as possible among the spring assemblies.
  - ⇒ The process is completed.

### Procedure for increasing conveying speed:

1. Remove leaf springs (⇒ chap. 9.3.3).
2. Start with a spring in a spring assembly.
3. If the speed still decreases when the fastening screw is loosened again, gradually install a spring and intermediate layer on each of the spring assemblies.
4. Distribute the number of leaf springs as evenly as possible among the spring assemblies.
  - ⇒ The process is completed.



After the adjustment work, the magnetic gap must be checked, as it can easily become misaligned during spring installation and removal. If this is the case, the magnet gap must be readjusted (⇒ chap. 9.4.1).

## 9.6 Further maintenance

Further maintenance is not required, if the ambient conditions listed below are complied with:

- Clean working area
- No use of splash water.
- No abrasion or process dusts.
- Environmental conditions as specified in the technical data.

## 9.7 Spare and wear parts, repairs

Afag Automation AG offers a reliable repair service. Defective bowl feeders can be sent to AFAG for warranty repair within the warranty period.

After expiry of the warranty period, the customer may replace or repair defective modules or wear parts himself or send them to the Afag repair service.



Please note that Afag does not assume any warranty for modules that have not been replaced or repaired by Afag!

### 9.7.1 Spare parts

Type	Designation	Mains connection	Order Number
WV401-1	Vibrating magnet	230 V / 50 Hz	15211762
		115 V / 60 Hz	15018561
WV402-1	Vibrating magnet	230 V / 50 Hz	15031196
		115 V / 60 Hz	15160938

### 9.7.2 Wear parts

Type	Designation	Order Number
WV401-1	Leaf spring 2 mm	50201924
WV402-1	Leaf spring 1 mm	50111450
WV401-1	Rubber buffer B	50177631
WV402-1		

### 10 Decommissioning and disposal

The bowl feeder must be properly dismantled after use and disposed of in an environmentally friendly manner.

#### 10.1 Safety instructions

##### WARNING



##### **Risk of injury due to improper decommissioning and disposal!**

Improperly carried out activities can result in considerable material damage and serious injury.

- Only use trained specialist personnel to carry out the activities.
  - Disconnect the media supply before dismantling the module!
  - Only remove the bowl feeder when the controller is switched off and secured!
- 

#### 10.2 Decommissioning

If the bowl feeders are not used for a longer period, they must be properly commissioned and stored as described in ↻ chap. 4.5.

#### 10.3 Disposal

The bowl feeders must be disposed of properly at the end of their service life and the raw materials used must be recycled. Observe the legal regulations and company requirements.

The bowl feeder must not be disposed of as a complete unit. Dismantle the bowl feeder and separate the various components according to type of material and dispose of them properly:

- Scrap the metallic materials.
- Hand over plastic parts for recycling.
- Sort the rest of the components by their material properties and dispose of them accordingly.

##### NOTICE

##### **Risk to the environment due to incorrect disposal of the bowl feeder!**

Environmental damage can be caused by improper disposal.

- Electronic parts, electrical scrap, auxiliary and operating materials must be disposed of by approved specialist companies.
  - Information on proper disposal can be obtained from the responsible local authorities.
-

