



**EMERSON**<sup>™</sup>

Original Instructions  
4000847 - REV. 02



# DCX F-EIP

## Power Supply

# Operating Manual

**Branson Ultrasonics Corp.**  
120 Park Ridge Road  
Brookfield, CT 06804  
(203) 796-0400  
<http://www.bransonultrasonics.com>

**BRANSON**

## Manual Change Information

At Branson, we strive to maintain our position as the leader in ultrasonics plastics joining, metal welding, cleaning and related technologies by continually improving our circuits and components in our equipment. These improvements are incorporated as soon as they are developed and thoroughly tested.

Information concerning any improvements will be added to the appropriate technical documentation at its next revision and printing. Therefore, when requesting service assistance for specific units, note the Revision information found on this document, and refer to the printing date which appears on this page.

## Copyright and Trademark Notice

Copyright © 2023 Branson Ultrasonics Corporation. All rights reserved. Contents of this publication may not be reproduced in any form without the written permission of Branson Ultrasonics Corporation.

Mylar is a registered trademark of DuPont Teijin Films.

Loctite is a registered trademark of Loctite Corporation.

WD-40 is a registered trademark of WD-40 Company.

Windows 7, Windows Vista, and Windows XP are registered trademarks of Microsoft Corporation.

Other trademarks and service marks mentioned herein are held by their respective owners.

## Foreword

Congratulations on your choice of a Branson Ultrasonics Corporation system!

The Branson DCX F-EIP Power Supply system is process equipment for the joining of plastic parts using ultrasonic energy. It is the newest generation of product using this sophisticated technology for a variety of customer applications. This Operating Manual is part of the documentation set for this system, and should be kept with the equipment.

Thank you for choosing Branson!

## Introduction

This manual is arranged into several structured chapters which will help you find the information you may need to know to safely handle, install, set up, program, operate, and/or maintain this product. Please refer to the [Table Of Contents](#) and/or the [Index](#) of this manual to find the information you may be looking for. In the event you require additional assistance or information, please contact our Product Support department (see [1.4 How to Contact Branson](#) for information on how to contact them) or your local Branson representative.



---

# Table Of Contents

---

**Chapter 1: Safety and Support**

1.1	Safety Requirements and Warnings . . . . .	2
1.2	General Precautions . . . . .	4
1.3	Warranty . . . . .	7
1.4	How to Contact Branson . . . . .	8
1.5	Returning Equipment for Repair . . . . .	9
1.6	Obtaining Replacement Parts . . . . .	12

**Chapter 2: Introduction**

2.1	Models Covered . . . . .	14
2.2	Compatibility with other Branson Products . . . . .	16
2.3	Features . . . . .	17
2.4	Controls and Indicators . . . . .	20
2.5	Welding Systems . . . . .	26
2.6	Glossary . . . . .	27

**Chapter 3: Delivery and Handling**

3.1	Shipping and Handling . . . . .	30
3.2	Receiving . . . . .	31
3.3	Unpacking the Power Supply . . . . .	32
3.4	Take Inventory of Small Parts . . . . .	33
3.5	Returning Equipment . . . . .	34

**Chapter 4: Technical Specifications**

4.1	Technical Specifications . . . . .	36
4.2	Physical Description . . . . .	39
4.3	EU Declaration of Conformity . . . . .	40
4.4	UK Declaration of Conformity . . . . .	41
4.5	Declaration of Conformity to the EtherNet/IP Specification . . . . .	42

**Chapter 5: Installation and Setup**

5.1	About Installation . . . . .	44
5.2	Installation Requirements . . . . .	45
5.3	Installation Steps . . . . .	51
5.4	Power Supply Setup . . . . .	74
5.5	Assembling the Acoustic Stack . . . . .	75
5.6	Converter Cooling . . . . .	80
5.7	Testing the Installation . . . . .	82
5.8	Still Need Help? . . . . .	83

**Chapter 6: Converters and Boosters**

6.1	Converters and Boosters . . . . .	86
-----	-----------------------------------	----

**Chapter 7: Operation**

7.1	Setting Primary Parameters . . . . .	98
7.2	Setting the Amplitude . . . . .	109
7.3	Resetting the Power Supply Alarms . . . . .	111
7.4	Configuring the Power Supply Registers . . . . .	112
7.5	LCD Bar-Graph . . . . .	117

7.6	Ultrasonics Test Procedure . . . . .	120
7.7	Using the I/O Connections . . . . .	122
<b>Chapter 8: EtherNet/IP Operation</b>		
8.1	EtherNet/IP . . . . .	124
8.2	EtherNet/IP Overview . . . . .	127
8.3	Message Type Definitions . . . . .	128
8.4	Communication to the CompactLogix Via EtherNet/IP . . . . .	129
8.5	Implicit Messaging . . . . .	133
8.6	Explicit Messaging . . . . .	146
8.7	Implicit Messaging . . . . .	153
8.8	Implicit Messaging Live Channel . . . . .	163
<b>Chapter 9: Maintenance</b>		
9.1	General Maintenance Considerations . . . . .	168
9.2	DCX F-EIP Power Supply Preventive Maintenance . . . . .	170
9.3	Recommended Spare Stock . . . . .	176
9.4	Circuit Diagram . . . . .	182
9.5	Troubleshooting . . . . .	183
9.6	Cold Start Procedure . . . . .	187
<b>Appendix A: Alarms</b>		
A.1	Overload Alarms (Group 0) . . . . .	190
A.2	Cutoff Alarms (Group 1) . . . . .	192
A.3	Setup Alarms (Group 2) . . . . .	193
A.4	Cycle Modified Alarms (Group 3) . . . . .	194
A.5	Warning Alarms (Group 4) . . . . .	195
A.6	Limit Alarms (Group 5) . . . . .	196
A.7	Equipment Failure Alarms (Group 6) . . . . .	197
A.8	No Cycle Alarms (Group 7) . . . . .	199
A.9	Communication Failure Alarms (Group 8) . . . . .	200
A.10	Hardware Alarms (Group A) . . . . .	201
A.11	Non-Cycle Overload Alarms (Group B) . . . . .	202
<b>Appendix B: EtherNet/IP Commands</b>		
B.1	Parameter Set Class 100 (32 Instances) . . . . .	206
B.2	Weld Data Class 101 (32 Instances) . . . . .	209
B.3	Stack Parameter Class 102 (16 Instances) . . . . .	211
B.4	Common Stack Parameters (16 Instances) . . . . .	212
B.5	Stack Status Class 103 (16 Instances) . . . . .	213
B.6	Alarm Data Class 104 (1 Instances) . . . . .	216
B.7	System Information Class 105 (1 Instances) . . . . .	217
B.8	Other Information Class 112 (1 Instances) . . . . .	218
B.9	Identity Object 1 (1 Instance) . . . . .	219
<b>Appendix C: Timing Diagrams</b>		
C.1	Timing Diagrams . . . . .	222
<b>Appendix D: Signal Diagrams</b>		
D.1	Signal Diagrams . . . . .	230

# List Of Figures

## Chapter 1: Safety and Support

Figure 1.1	Safety-related Labels found on the DCX F-EIP Power Supply. . . . .	3
------------	--	---

## Chapter 2: Introduction

Figure 2.1	The DCX F-EIP Power Supply (Horizontal) . . . . .	15
Figure 2.2	The DCX F-EIP Power Supply (Vertical) . . . . .	15
Figure 2.3	DCX F-EIP Power Supply Front Panel Controls and Indicators . . . . .	20
Figure 2.4	LCD Description. . . . .	22
Figure 2.5	DCX F-EIP Power Supply Back Panel (Horizontal) . . . . .	25
Figure 2.6	DCX F-EIP Power Supply Bottom Panel (Vertical). . . . .	25

## Chapter 3: Delivery and Handling

## Chapter 4: Technical Specifications

Figure 4.1	EU Declaration of Conformity . . . . .	40
Figure 4.2	UK Declaration of Conformity . . . . .	41
Figure 4.3	Declaration of Conformity to the EtherNet/IP Specification . . . . .	42

## Chapter 5: Installation and Setup

Figure 5.1	DCX F-EIP Power Supply Benchtop Dimensional Drawing . . . . .	46
Figure 5.2	DCX F-EIP Power Supply Vertical Mount dimensional drawing (400 W, 750 W & 800 W) . . . . .	47
Figure 5.3	DCX F-EIP Power Supply Vertical Mount dimensional drawing (1.25 kW and 1.5 kW) . . . . .	48
Figure 5.4	DCX F-EIP Power Supply Vertical Mount dimensional drawing (2.5 kW and 4 kW) . . . . .	49
Figure 5.5	LCD Viewing Angle . . . . .	53
Figure 5.6	DCX F-EIP Power Supply Connections (Horizontal Model) . . . . .	54
Figure 5.7	DCX F-EIP Power Supply Connections (Vertical Model) . . . . .	55
Figure 5.8	User I/O Cable Identification and Wire Color Diagram . . . . .	57
Figure 5.9	Typical Digital I/O Wiring Examples . . . . .	70
Figure 5.10	Typical Analog I/O Wiring Examples. . . . .	70
Figure 5.11	RF Cable Connection . . . . .	71
Figure 5.12	Assembling the Acoustic Stack . . . . .	76
Figure 5.13	Connecting Tip to Horn. . . . .	79

## Chapter 6: Converters and Boosters

Figure 6.1	20 kHz typical Converter Dimensions. . . . .	86
Figure 6.2	20 kHz Booster Dimensions . . . . .	87
Figure 6.3	20 kHz Converter/Booster/Horn, Typical Dimensions . . . . .	88
Figure 6.4	30 kHz Converter Dimensions . . . . .	89
Figure 6.5	30 kHz Booster Dimensions . . . . .	90
Figure 6.6	30 kHz Converter/Booster/Horn, Typical Dimensions . . . . .	91
Figure 6.7	40 kHz, 4TR Converter Dimensions . . . . .	92
Figure 6.8	40 kHz Booster Dimensions . . . . .	93
Figure 6.9	40 kHz Converter/Booster/Horn, Typical Dimensions . . . . .	94

## Chapter 7: Operation

Figure 7.1	LCD at Power Up . . . . .	109
Figure 7.2	LCD when in External Amplitude Control Mode . . . . .	110
Figure 7.3	Test Connections. . . . .	122

## Chapter 8: EtherNet/IP Operation

Figure 8.1	LED Status Indicator . . . . .	124
Figure 8.2	I/O Setup for EtherNet/IP Module With Standard Configuration . . . . .	133
Figure 8.3	RSLogix 5000 Implementation of Token . . . . .	147
Figure 8.4	Web Page Indication of Token Being Established . . . . .	147
Figure 8.5	RSLogix 5000 Implementation of Token Release. . . . .	148
Figure 8.6	Web Page Indication of Token Being Released . . . . .	148
Figure 8.7	RSLogix 5000 Implementation of Get Energy Value . . . . .	150
Figure 8.8	RSLogix 5000 Implementation of Set Energy Value. . . . .	152
Figure 8.9	PLC Output STW1/STW2 = 0 . . . . .	155
Figure 8.10	PLC Input ZSW1= 16, ZSW2=1024 . . . . .	155
Figure 8.11	DCX Fieldbus Diagnostic . . . . .	155
Figure 8.12	DCX Weld Mode - Sending a 513 Command - Weld Time . . . . .	156
Figure 8.13	DCX Fieldbus Diagnostic Page . . . . .	156
Figure 8.14	DCX Weld Mode - Sending a 513 Command - Hold Time . . . . .	157
Figure 8.15	DCX Fieldbus Diagnostic . . . . .	157
Figure 8.16	DCX Weld Mode - Sending a 0 Command - Changeover State . . . . .	158
Figure 8.17	DCX Fieldbus Diagnostic Page . . . . .	158
Figure 8.18	DCX Weld Mode - Sending a 513 and Holding It to Create a "Start Input is Active" Alarm . . . . .	159
Figure 8.19	DCX Fieldbus Diagnostics. . . . .	159
Figure 8.20	DCX Weld Mode - Alarm Reset . . . . .	160
Figure 8.21	DCX Weld Mode - Alarm Reset (Cont) . . . . .	161
Figure 8.22	DCX Fieldbus Diagnostic . . . . .	161
Figure 8.23	DCX Weld Mode - Alarm Reset (Cont) . . . . .	162
Figure 8.24	DCX Fieldbus Diagnostic . . . . .	162
Figure 8.25	Implicit Messaging . . . . .	163
Figure 8.26	Data Going to the DCX (Control) . . . . .	163
Figure 8.27	Data Coming from the DCX (Status) . . . . .	164
Figure 8.28	DCX Status Word . . . . .	165
Figure 8.29	Status Word (Web Page Interface) . . . . .	165
Figure 8.30	DCX Control Word. . . . .	166
Figure 8.31	DCX Control Word (Web Page Interface) . . . . .	166

## Chapter 9: Maintenance

Figure 9.1	Reconditioning Stack Mating Surfaces . . . . .	173
Figure 9.2	Interconnect Diagram, Power Supply . . . . .	182

## Appendix A: Alarms

## Appendix B: EtherNet/IP Commands

## Appendix C: Timing Diagrams

Figure C.1	RF Switching Direct With Feedback, With And Without Alarm . . . . .	222
Figure C.2	RF Switching I/O Direct With Feedback, With And Without Alarm . . . . .	222
Figure C.3	RF Switching I/O Direct With Feedback With And Without Alarm And Load On Start . . . . .	223
Figure C.4	RF Switching I/O With Off, With And Without Alarm, And Load On Start . . . . .	223
Figure C.5	RF Switching I/O With Off, With Feedback, With And Without Alarm . . . . .	224
Figure C.6	RF Switching With Off, With Feedback, With And Without Alarm. . . . .	224
Figure C.7	Timing Diagram For All Other Modes With Actuator. . . . .	225
Figure C.8	Timing Diagram For Cycle Abort With Actuator. . . . .	226
Figure C.9	Timing Diagram For Ground Detect With Actuator. . . . .	227

## Appendix D: Signal Diagrams

Figure D.1	Continuous Mode . . . . .	230
Figure D.2	Time Mode. . . . .	231
Figure D.3	AE Actuator . . . . .	232



# List Of Tables

## Chapter 1: Safety and Support

Table 1.1	Branson Contacts	11
-----------	------------------	----

## Chapter 2: Introduction

Table 2.1	Models Covered in this Manual	14
Table 2.2	Power Supply Compatibility with Branson Converters	16
Table 2.3	DCX F-EIP Power Supply Front Panel Controls and Indicators	20
Table 2.4	LCD Description	22
Table 2.5	Connections to the DCX F-EIP Power Supply	25

## Chapter 3: Delivery and Handling

Table 3.1	Shipping Specifications	30
Table 3.2	Inspect the Power Supply	31
Table 3.3	Unpacking the Power Supply	32
Table 3.4	Small Parts included: Power Supply Assemblies	33
Table 3.5	DCX F-EIP Power Supply System Cables	33

## Chapter 4: Technical Specifications

Table 4.1	Environmental Specifications	36
Table 4.2	Electrical Input Operating Voltages	37
Table 4.3	Input Current and Circuit Breaker Specifications	38
Table 4.4	Continuous Duty Maximum Power	38
Table 4.5	DCX F-EIP Power Supply	39

## Chapter 5: Installation and Setup

Table 5.1	DCX F-EIP Power Supply Benchtop Dimensional Drawing	46
Table 5.2	DCX F-EIP Power Supply Vertical Mount dimensional drawing (400 W, 750 W & 800 W)	47
Table 5.3	DCX F-EIP Power Supply Vertical Mount dimensional drawing (1.25 kW and 1.5 kW)	48
Table 5.4	DCX F-EIP Power Supply Vertical Mount dimensional drawing (2.5 kW and 4 kW)	49
Table 5.5	Environmental Requirements	50
Table 5.6	Input Current and Circuit Breaker Specifications	50
Table 5.7	DCX F-EIP Power Supply Connections (Horizontal Model)	54
Table 5.8	DCX F-EIP Power Supply Connections (Vertical Model)	55
Table 5.9	User I/O Cable Identification and Wire Color Diagram	57
Table 5.10	User I/O Cable Pin Assignments	58
Table 5.11	Digital Input Functions	60
Table 5.12	Digital Output Functions	62
Table 5.13	Analog Input Functions	64
Table 5.14	Analog Output Functions	65
Table 5.15	Default Branson User I/O Connector PIN Assignments, V6.0	66
Table 5.16	Default Branson User I/O Connector PIN Assignments, V6.5	68
Table 5.17	RF Cable Connection	71
Table 5.18	Input Power Connection	72
Table 5.19	Acoustic Stack Description	76
Table 5.20	Stack Torque Values	77
Table 5.21	Tools	77
Table 5.22	20 kHz System	78
Table 5.23	30 kHz System	78

Table 5.24	40 kHz System . . . . .	78
Table 5.25	Tip to horn torque values. . . . .	79
Table 5.26	Continuous Duty Max. Power & Full Power Duty Cycle . . . . .	80
Table 5.27	Converter Cooling Procedure . . . . .	81

## Chapter 6: Converters and Boosters

Table 6.1	20 kHz Converter . . . . .	86
Table 6.2	20 kHz Booster. . . . .	87
Table 6.3	20 kHz Converter/Booster/Horn . . . . .	88
Table 6.4	30 kHz Converter . . . . .	89
Table 6.5	30 kHz Booster. . . . .	90
Table 6.6	30 kHz Converter/Booster/Horn . . . . .	91
Table 6.7	40 kHz, 4TR Converter . . . . .	92
Table 6.8	40 kHz Booster. . . . .	93
Table 6.9	40 kHz Converter/Booster/Horn . . . . .	94

## Chapter 7: Operation

Table 7.1	Summary of Weld Modes . . . . .	98
Table 7.2	Continuous Mode Operational Sequence . . . . .	99
Table 7.3	Time Mode Parameters . . . . .	101
Table 7.4	Selecting Time Mode . . . . .	101
Table 7.5	Setting Time Mode Parameters. . . . .	102
Table 7.6	Energy Mode Parameters. . . . .	103
Table 7.7	Selecting Energy Mode . . . . .	103
Table 7.8	Setting Energy Mode Parameters . . . . .	104
Table 7.9	Peak Power Mode Parameters . . . . .	105
Table 7.10	Selecting Peak Power Mode . . . . .	105
Table 7.11	Setting Peak Power Mode Parameters . . . . .	106
Table 7.12	Ground Detect Mode Parameters . . . . .	107
Table 7.13	Selecting Ground Detect Mode . . . . .	107
Table 7.14	Setting Ground Detect Mode Parameters . . . . .	108
Table 7.15	Setting the Amplitude Using the Front Panel Controls . . . . .	109
Table 7.16	Resetting the DCX F-EIP Power Supply . . . . .	111
Table 7.17	Steps to Configure the Power Supply Registers . . . . .	112
Table 7.18	Power Supply Registers . . . . .	114
Table 7.19	Power Bar-Graph Interpretation Examples . . . . .	117
Table 7.20	Frequency Bar-Graph Interpretation - 20 kHz (50 Hz Segment) . . . . .	118
Table 7.21	Frequency Bar-Graph Interpretation - 30 kHz (76 Hz Segment) . . . . .	118
Table 7.22	Frequency Bar-Graph Interpretation - 40 kHz (100 Hz/Segment) . . . . .	119
Table 7.23	Frequency Bar-Graph Interpretation Examples. . . . .	119
Table 7.24	Power Supply Ultrasonic Test Procedure (Front Panel) . . . . .	120
Table 7.25	Power Supply . . . . .	122

## Chapter 8: EtherNet/IP Operation

Table 8.1	DCX F-EIP Power Supply LED Status Indicator . . . . .	124
Table 8.2	DCX Inputs/PLC Outputs (8 bytes) . . . . .	134
Table 8.3	Control Word (STW1) . . . . .	135
Table 8.4	HFS Bit (Control Word) . . . . .	136
Table 8.5	PSN Bit (Control Word) . . . . .	136
Table 8.6	Control Word (STW2) . . . . .	138
Table 8.7	DCX Outputs/PLC Inputs (20 bytes) . . . . .	139
Table 8.8	Status Word (ZSW1) . . . . .	140
Table 8.9	HFS Bit (Status Word) . . . . .	141
Table 8.10	PSN Bit (Status Word) . . . . .	141
Table 8.11	Status Word (ZSW2) . . . . .	143
Table 8.12	Stack Function . . . . .	144
Table 8.13	Implicit Message for Run . . . . .	144

Table 8.14	Implicit Message for Seek	144
Table 8.15	Implicit Message for Scan	145
Table 8.16	Implicit Message for Reset	145
Table 8.17	Establishing Token	146
Table 8.18	Attribute ID	146
Table 8.19	Common Services	146
Table 8.20	RSLogix 5000 Implementation of Token	147
Table 8.21	RSLogix 5000 Implementation of Token Release	148
Table 8.22	Get Energy Value Example	149
Table 8.23	Attribute ID	149
Table 8.24	Common Services	149
Table 8.25	RSLogix 5000 Implementation of Get Energy Value	150
Table 8.26	Get Energy Value Example	151
Table 8.27	Attribute ID	151
Table 8.28	Common Services	151
Table 8.29	RSLogix 5000 Implementation of Set Energy Value	152
Table 8.30	Control/Status Word (Time Mode)	153
Table 8.31	DCX Outputs/PLC Inputs (20 bytes)	153
Table 8.32	DCX Input	154

## Chapter 9: Maintenance

Table 9.1	Stack Reconditioning Procedure	172
Table 9.2	Reconditioning Stack Mating Surfaces	173
Table 9.3	Stack Torque Values	173
Table 9.4	Stack Reassembly for a 20 kHz System	174
Table 9.5	Stack Reassembly for a 30 kHz System	174
Table 9.6	Stack Reassembly for a 40 kHz System	175
Table 9.7	Stud Torque Values	175
Table 9.8	DCX F-EIP Power Supply System Cables	176
Table 9.9	Suggested Spares	177
Table 9.10	Converters Compatible with the DCX F-EIP Power Supply	178
Table 9.11	DCX F-EIP Power Supply Compatible Boosters	179
Table 9.12	Other Items used with the DCX F-EIP Power Supply	181
Table 9.13	Troubleshooting	183
Table 9.14	Troubleshooting Common Electrical Problems	184
Table 9.15	Troubleshooting Ultrasonic Power Problems	185
Table 9.16	Troubleshooting Weld Cycle Problems	186
Table 9.17	Steps to Perform a Cold Start	187

## Appendix A: Alarms

Table A.1	Overload Alarms (Group 0)	190
Table A.2	Cutoff Alarms (Group 1)	192
Table A.3	Cycle Modified Alarms (Group 2)	193
Table A.4	Cycle Modified Alarms (Group 3)	194
Table A.5	Warning Alarms (Group 4)	195
Table A.6	Limit Alarms (Group 5)	196
Table A.7	Equipment Failure Alarms (Group 6)	197
Table A.8	No Cycle Alarms (Group 7)	199
Table A.9	Communication Failure Alarms (Group 8)	200
Table A.10	Hardware Alarms (Group A)	201
Table A.11	Non-Cycle Overload Alarms (Group B)	202

## Appendix B: EtherNet/IP Commands

Table B.1	Parameter Set Class	206
Table B.2	Common Services	208
Table B.3	Weld Data Class	209
Table B.4	Common Services	210

Table B.5	Stack Parameter Class (Seek Results)	211
Table B.6	Stack Parameter Class (Test Results)	211
Table B.7	Common Services	211
Table B.8	Common Stack Parameters	212
Table B.9	Stack Status Class (Seek)	213
Table B.10	Stack Status Class (Test)	213
Table B.11	Stack Status Class (Scan)	214
Table B.12	Common Services	215
Table B.13	Alarm Data Class	216
Table B.14	Common Services	216
Table B.15	System Information Class	217
Table B.16	Common Services	217
Table B.17	Other Information Class	218
Table B.18	System Configuration Parameters	218
Table B.19	Common Services	218
Table B.20	Identity Object (1 - 1 Instance)	219
Table B.21	Common Services	219

## **Appendix C: Timing Diagrams**

## **Appendix D: Signal Diagrams**

---

# Chapter 1: Safety and Support

---



1.1	Safety Requirements and Warnings . . . . .	2
1.2	General Precautions . . . . .	4
1.3	Warranty. . . . .	7
1.4	How to Contact Branson . . . . .	8
1.5	Returning Equipment for Repair. . . . .	9
1.6	Obtaining Replacement Parts. . . . .	12

## 1.1 Safety Requirements and Warnings

This chapter contains an explanation of the different Safety Notice symbols and icons found both in this manual and on the product itself and provides additional safety information for ultrasonic welding. This chapter also describes how to contact Branson for assistance.

### 1.1.1 Symbols Found in this Manual

These symbols used throughout this manual warrant special attention:

<b>WARNING</b>	<b>Indicates a possible danger</b>
	If these risks are not avoided, death or severe injury might result.
<b>CAUTION</b>	<b>Indicates a possible danger</b>
	If these risks are not avoided, slight or minor injury might result.
<b>NOTICE</b>	<b>Indicates a possible damaging situation</b>
	If this situation is not avoided, the system or something in its vicinity might get damaged. Application types and other important or useful information are emphasized.

## 1.1.2 Symbols Found on the Product

The DCX F-EIP Power Supply has several safety-related labels on it to indicate the presence of hazardous voltages inside the unit.

**Figure 1.1** Safety-related Labels found on the DCX F-EIP Power Supply

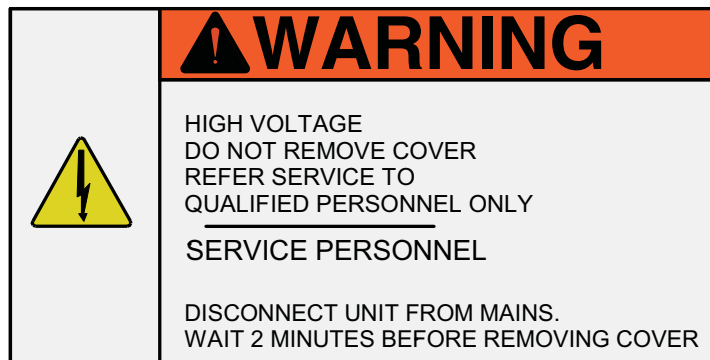

## 1.2 General Precautions

Take the following precautions before servicing the power supply:

- Be sure the power switch is in the off position before making any electrical connections
- To prevent the possibility of an electrical shock, always plug the power supply into a grounded power source
- To prevent the possibility of an electrical shock, ground the power supply by securing an 8 gauge grounded conductor to the ground screw located next to the air outlet
- Power supplies produce high voltage. Before working on the power supply assembly, do the following:  
Turn off the power supply;  
Unplug main power; and  
Allow at least 2 minutes for capacitors to discharge
- High voltage is present in the power supply. Do not operate with the cover removed
- High line voltages exist in the ultrasonic power supply assembly. Common points are tied to circuit reference, not chassis ground. Therefore, use only non-grounded, battery-powered multimeters when testing the power supply assembly. Using other types of test equipment can present a shock hazard
- Keep hands from under the horn. Down force (pressure) and ultrasonic vibrations can cause injury
- Do not cycle the welding system if either the RF cable or converter is disconnected
- When using larger horns, avoid situations where fingers could be pinched between the horn and the fixture
- Ensure power supply installation is performed by qualified personnel and in accordance with local standards and regulations

CAUTION	Loud Noise Hazard
	<p>Sound level and frequency of the noise emitted during the ultrasonic assembly process may depend upon a. type of application, b. size, shape and composition of the material being assembled, c. shape and material of the holding fixture, d. welder setup parameters and e. tool design.</p> <p>Some parts vibrate at an audible frequency during the process. Some or all of these factors may result in an uncomfortable noise being emitted during the process.</p> <p>In such cases operators may need to be provided with personal protective equipment. See 29 CFR (Code of Federal Regulations) 1910.95 Occupational Noise Exposure.</p>

NOTICE	
	<p>When the battery is worn out, dispose it under the ordinance of each local government.</p>



CAUTION	Corrosive Material Hazard
	<p>First aid measures (in case of electrolyte leakage from the battery):</p> <p><b>Eye Contact:</b> Flush the eyes with plenty of clean water for at least 15 minutes immediately, without rubbing. Get immediate medical treatment. If appropriate procedures are not taken, this may cause eye injury.</p> <p><b>Skin Contact:</b> Wash the affected area under tepid running water using a mild soap. If appropriate procedures are not taken, this may cause sores on the skin. Get medical attention if irritation develops or persists.</p> <p><b>Inhalation:</b> Remove to fresh air immediately. Get medical treatment immediately.</p>

## 1.2.1 Intended Use of the System

The DCX F-EIP Power Supply and components are designed to be used as part of an ultrasonic welding system. These are designed for a wide variety of welding or processing applications.

If the equipment is used in a manner not specified by Branson, the protection provided by the equipment may be impaired.

Branson Ultrasonics Corporation designs and manufactures machines giving the first priority to safety precautions, to allow customers to use the machines safely and effectively. Only trained operators should run and service the equipment. Untrained operators can misuse the equipment or ignore safety instructions that can result in personal injury or equipment damage. It is most essential that all operators and service personnel pay attention to safety instructions when operating and servicing the equipment.

## 1.2.2 Emissions

Because of the various types of toxic or injurious gases that may be liberated during the welding based on the material being processed, sufficient ventilation should be provided to prevent a concentration of these gases in excess of 0.1 ppm. Check with your materials suppliers for recommended protection when processing their materials.

CAUTION	Corrosive Material Hazard
	Processing of many materials, such as PVC, can be hazardous to an operator's health and could cause corrosion/damage to the equipment. Use proper ventilation and take protective measures.

## 1.2.3 Setting up the Workplace

Measures for setting up a workplace for safe operation of the ultrasonic welder are outlined in [Chapter 5: Installation and Setup](#).

## 1.2.4 Regulatory Compliance

This product meets electrical safety requirements and EMC (Electromagnetic Compliance) requirements for North America, Great Britain and the European Union.

## 1.3 Warranty

For warranty information please reference the warranty section of Terms and Conditions found at: [www.emerson.com/branson-terms-conditions](http://www.emerson.com/branson-terms-conditions).

## 1.4 How to Contact Branson

Branson is here to help you. We appreciate your business and are interested in helping you successfully use our products. To contact Branson for help, use the following telephone numbers, or contact the field office nearest you (business hours from 8 a.m. to 4 p.m. Central and Eastern Time Zones):

- **North American Headquarters (all Departments):** (203) 796-0400
- **Parts Store (direct number):** (877) 330-0406
- **Repair department:** (877)-330-0405
- **For emergency after-hours service (5 p.m. – 8 a.m. EST):** (203) 796-0500 (US phone numbers only)

Tell the operator which product you have and which person or department you need ([Table 1.1 Branson Contacts](#)). If after hours, please leave a voice message with your name and return telephone number.

### 1.4.1 Before Calling Branson for Assistance

This manual provides information for troubleshooting and resolving problems that could occur with the equipment (see [Chapter 9: Maintenance](#)). If you still require assistance, Branson Product Support is here to help you. To help identify the problem, use the following questionnaire which lists the common questions you will be asked when you contact the Product Support department.

Before calling, determine the following information:

1. Your company name and location.
2. Your return telephone number.
3. Have your manual with you. If troubleshooting a problem, refer to [Chapter 9: Maintenance](#).
4. Know your equipment model and serial numbers (found on a gray data label on the units). Information about the horn (part number, gain, etc.) or other tooling may be etched into the tooling. Software- or firmware-based systems may provide a BOS or software version number, which may be required.
5. What tooling (horn) and booster are being used?
6. What are the setup parameters and mode?
7. Is your equipment in an automated system? If so, what is supplying the “start” signal?
8. Describe the problem; provide as much detail as possible. For example, is the problem intermittent? How often does it occur? How long before it occurs if you are just powering up? If an error is occurring, which error (give error number or name)?
9. List the steps you have already taken.
10. What is your application, including the materials being processed?
11. Have a list of service or spare parts you have on hand (tips, horns, etc.)
12. Notes:

---

---

---

---

## 1.5 Returning Equipment for Repair

Before sending equipment for repair, provide as much information with the equipment to help determine the problem with the system. Use the following page to record necessary information.

NOTICE	
	<p>To return equipment to Branson, you must first obtain an RGA number from a Branson representative, or the shipment may be delayed or refused.</p>

If you are returning equipment to Branson for repair, you must first call the Repair department to obtain a **Returned Goods Authorization (RGA)** number. (If you request it, the repair department will fax a Returned Goods Authorization form to fill out and return with your equipment).

Branson Repair Department, C/O Zuniga Logistics, LTD

12013 Sara Road, Killam Industrial Park

Laredo, Texas 78045 U.S.A.

Direct telephone number: (877) 330-0405

Fax number: (877) 330-0404

- Provide as much information as possible that will help identify the need for repair
- Carefully pack the equipment in original packing cartons
- Clearly label all shipping cartons with the RGA number on the outside of cartons as well as on your packing slip, along with the reason for return
- Return general repairs by any convenient method. Send priority repairs by air freight
- You must prepay the transportation charges FOB Laredo, Texas, U.S.A.

### 1.5.1 Get an RGA Number

RGA#

---

If you are returning equipment to Branson, please call the Repair Department to obtain a Returned Goods Authorization (RGA) number. (At your request, the Repair Department will fax an RGA form to fill out and return with the equipment.)

## 1.5.2 Record Information About the Problem

Before sending equipment for repair, record the following information and send a copy of it with the equipment. This will greatly increase Branson's ability to address the problem.

1. Describe the problem; provide as much detail as possible. For example, is the problem intermittent? How often does it occur? How long before it occurs after powering up?

---

---

---

2. Is your equipment in an automated system?

---

---

3. If the problem is with an external signal, which signal?

---

---

4. If known, include plug/pin # (e.g., P29, pin #3) for that signal:

---

---

5. What are the Weld Parameters?

---

---

---

6. What is your application (type of weld, plastic material, etc.)?

---

---

---

7. Name and phone number of the person most familiar with the problem:

---

---

---

Contact the Branson office prior to shipping the equipment.

For equipment not covered by warranty, to avoid delay, include a Purchase Order.

Send a copy of this page with the equipment being returned for repair.

## 1.5.3 Departments to Contact

Call your local Branson Representative, or contact Branson by calling and asking for the appropriate department, as indicated in [Table 1.1 Branson Contacts](#) below.

**Table 1.1** Branson Contacts

What you need help with or information about	Whom to Call	At this Phone Number...
Information about new welding systems or components	Your local Branson Rep or Branson Customer Service	203-796-0400 Ext 384
Application and setup questions on the welding system	Welding Applications Lab	203-796-0400 Ext 368
Application assistance on the horns and tooling	ATG Lab	203-796-0400 Ext 495
Technical questions about the welding system	Welding Product Support	203-796-0400 Ext 355, 551
Technical questions about horns and tooling	ATG Lab	203-796-0400 Ext 495
Ordering new parts	Parts Store	877-330-0406
RGA's, request for repair, status of a repair	Welding Repair Department	877-330-0405
System automation/hookup information	Product Support	203-796-0400 Ext 355, 551

My Local Branson Representative's name is:

---



---

I can reach this representative at:

---



---

## 1.5.4 Pack and Ship the Equipment

- Carefully pack the system in original packing material to avoid shipping damage. Plainly show the RGA number on the outside of cartons as well as inside the carton along with the reason for return. Make a list of all components packed in the box. KEEP YOUR MANUAL.
- Return general repairs by any convenient method. Send priority repairs by air freight. Prepay the transportation charges FOB the repair site.

NOTICE	
	Items that are sent Freight Collect will be refused.

## 1.6 Obtaining Replacement Parts

You can reach Branson Parts Store at the following telephone numbers:

Branson Part Store

Direct telephone number: 877-330-0406

Fax number: 877-330-0404

Many parts can be shipped the same day if ordered before 2:30 p.m., Eastern time.

A parts list is found in [Chapter 9: Maintenance](#) of this manual, listing descriptions and EDP part numbers. If you need replacement parts, coordinate the following with your purchasing agent:

- Purchase order number
- Ship to information
- Bill to information
- Shipping instructions (air freight, truck, etc.)
- Any special instructions (for example, "Hold at the airport and call"). Be sure to give a name and phone number
- Contact name information



---

## Chapter 2: Introduction

---

2.1	Models Covered . . . . .	14
2.2	Compatibility with other Branson Products . . . . .	16
2.3	Features . . . . .	17
2.4	Controls and Indicators . . . . .	20
2.5	Welding Systems . . . . .	26
2.6	Glossary . . . . .	27

## 2.1 Models Covered

This manual covers all models of the DCX F-EIP Power Supply.

**Table 2.1** Models Covered in this Manual

Frequency	Power	Model	EDP
20 kHz	1250 W	Horizontal	101-132-1836
		Vertical	101-132-1843
	2500 W	Horizontal	101-132-1837
		Vertical	101-132-1844
	4000 W	Horizontal	101-132-1838
		Vertical	101-132-1845
30 kHz	750 W	Horizontal	101-132-1839
		Vertical	101-132-1846
	1500 W	Horizontal	101-132-1840
		Vertical	101-132-1847
40 kHz	400 W	Horizontal	101-132-1835
		Vertical	101-132-1842
	800 W	Horizontal	101-132-1841
		Vertical	101-132-1848

## 2.1.1 Overview of these Models

**Figure 2.1** The DCX F-EIP Power Supply (Horizontal)



**Figure 2.2** The DCX F-EIP Power Supply (Vertical)



## 2.2 Compatibility with other Branson Products

**Table 2.2** Power Supply Compatibility with Branson Converters

DCX F-EIP Model	Converter
20 kHz / 1250 W 20 kHz / 2500 W 20 kHz / 4000 W	CR-20
	CR-20S
	CR-20C
	CH-20S (932 AH SPL)
	CH-20C
	CS-20S CS-20C
30 kHz / 750 W 30 kHz / 1500 W	CR-30S
	CR-30C
	CH-30S
	CH-30C
	CS-30S CS-30C
40 kHz / 400 W 40 kHz / 800 W	CR-40S (4TH)
	CR-40C
	4TP
	4TR

NOTICE	
	<p>Special adaptor cables are available to connect to MS-style converters (CR20 and 4TR). See <a href="#">Table 9.8 DCX F-EIP Power Supply System Cables</a>.</p>

## 2.3 Features

### 2.3.1 The Welding System

The DCX F-EIP Power Supply generates ultrasonic energy through an ultrasonic converter for welding plastics. Several models are available, depending on the desired frequency (for example, 20 kHz), the desired power range (for example, 2.5 kW), and the intended mounting arrangement (horizontal or vertical). The power supply also contains a microprocessor-based controller module that provides for control and monitoring of welding operations.

The welding system consists of a DCX F-EIP Power Supply and a converter-booster-horn stack. The system can perform ultrasonic welding, inserting, staking, spot welding, swaging, degating, and continuous ultrasonic operations. It is designed for automated, semi-automated and/or manual production operations.

### 2.3.2 The Power Supply

The DCX F-EIP Power Supply consists of an ultrasonic power supply assembly with a system controller and user interfaces. The ultrasonic power supply assembly converts conventional 50/60 Hz line current to 20 kHz, 30 kHz or 40 kHz electrical energy. The system controller controls the welding system.

Listed below are the control features of the Branson DCX F-EIP Power Supply ultrasonic welding system

- **Autotuning:** Branson power supply tuning ensures that the system is running at peak efficiency
- **Digital Amplitude Setting:** This feature allows you to set the exact amplitude necessary for your application, allowing increased range and setting repeatability over analog systems
- **EtherNet/IP:** Provides plant-wide network systems using open, industry-standard networking technologies. This combination of well-accepted standards provides the functionality required to support both information data exchange as well as control applications
- **Frequency Offset:** This process feature allows a user to set an offset relative to the starting frequency, for certain specific applications, where the force imparted on the fixture or anvil causes a frequency shift in the stack's operation. You should only use this feature when advised to do so by Branson
- **Horn Signature:** Using the DCX F-EIP Power Supply Web Page Interface, you may scan your ultrasonic stack to view its operating frequency on your computer, using digital readouts to give you the best picture of the stack's operation
- **LCD (Liquid Crystal Display):** Provides a clear visual interface to monitor and configure the system
- **Line Regulation:** Maintains converter amplitude by regulating for variances in the line voltages
- **Load Regulation:** Maintains converter amplitude over the full range of rated power
- **Membrane Keys:** Front panel controls are designed for high reliability and immunity from factory dust and oils
- **User ID and Passcodes:** Allows for keeping track of user access to the DCX F-EIP Power Supply Web Page Interface
- **Ramp Starting:** The starting of the DCX F-EIP Power Supply and horn is done at a rate that helps reduce electrical and mechanical stress on the system. The horn start rate may be adjusted for some tough-to-start applications
- **Seek:** Ensures operation at resonance; minimizes tuning errors; and operates the stack at low amplitude (10%), then provides a means of sensing and storing the resonant operating frequency value
- **Start-up Diagnostics:** At start-up, the controls test the major internal components
- **System Protection:** Protects the power supply by providing six levels of protection: Voltage, Current, Phase, Temperature, Power and Frequency

- **Timed Seek:** When enabled, will do a Seek once every minute to update horn resonant frequency to memory. This is especially useful when the welding process affects the actual temperature of the horn, causing a resonant frequency shift
- **True Wattmeter:** The controls on the power supply include a true wattmeter for accurate measurement of power and energy
- **Web Page Interface:** Provides access, via Ethernet connection, to power supply information, diagnostics, and configuration web pages

### 2.3.3 The Actuator

The DCX F-EIP Power Supply can interface with actuator signals, only when operating in manual mode.

### 2.3.4 Converter/Booster/Horn Assembly

#### The Converter

The ultrasonic electrical energy from the power supply is applied to the converter (sometimes called the transducer). This transforms the high frequency electrical oscillations into mechanical vibrations at the same frequency as the electrical oscillations. The heart of the converter is piezoelectric ceramic elements. When subjected to an alternating voltage, these elements alternately expand and contract, resulting in better than 90% conversion of electrical to mechanical energy.

#### The Booster

Success in ultrasonic assembly depends on the right amplitude of movement at the horn face. Amplitude is a function of horn shape, which is largely determined by the size and form of the parts to be assembled. The booster can be used as a mechanical transformer to increase or decrease the amplitude of vibrations applied to the parts through the horn.

The booster is a resonant half-wave section of aluminum or titanium. It is mounted between the converter and the horn, as part of the ultrasonic stack. It also provides a clamping point for rigid stack mounting.

Boosters are designed to resonate at the same frequency as the converter with which they are used. Boosters are usually mounted at a nodal (minimum vibration) point of axial motion. This minimizes the loss of energy and prevents vibration from being transmitted to the stack supporting structure.

## **The Horn**

The horn is selected or designed for a specific application. Each horn is tuned typically as a half-wave section that applies the necessary force and vibration uniformly to the parts to be assembled. It transfers ultrasonic vibrations from the converter to the workpiece. The horn is mounted to the booster as part of the ultrasonic stack.

Depending on their profile, horns are referred to as stepped, conical, exponential, bar, or catenoidal. The shape of the horn determines the amplitude at the face of the horn. Depending on the application, horns can be made from titanium alloys, aluminum, or steel. Titanium alloys are the best materials for horn fabrication due to their high level of strength and low loss. Aluminum horns are usually chrome- or nickel-plated or hard-coated to reduce wear. Steel horns are for low amplitude requiring hardness, such as ultrasonic insertion applications.



## 2.4 Controls and Indicators

### 2.4.1 DCX F-EIP Power Supply Front Panel

Figure 2.3 DCX F-EIP Power Supply Front Panel Controls and Indicators

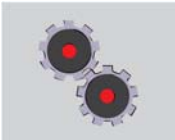

Table 2.3 DCX F-EIP Power Supply Front Panel Controls and Indicators

Reference	Description
	<p><b>LCD</b></p> <p>For detailed information refer to <a href="#">Figure 2.4 LCD Description</a> and <a href="#">Table 2.4 LCD Description</a>.</p>
	<p><b>Up/Down Keys</b></p> <p>Use to adjust the amplitude of ultrasonic vibrations (10% to 100%). Also used to adjust weld mode parameters, select registers and edit register values.</p>
	<p><b>Alarm Reset Key</b></p> <p>Use the Reset key to reset alarms.</p> <p>When changing system registers, use the Reset key to set a register back to its default value after entering the register and before editing the value.</p>
	<p><b>Configuration Key</b></p> <p>Use the Configuration key to change system registers. For information on using the Configuration key to set system registers see <a href="#">7.4 Configuring the Power Supply Registers</a>.</p>



**Table 2.3** DCX F-EIP Power Supply Front Panel Controls and Indicators





Reference	Description
	<p><b>Ultrasonics Test Key</b></p> <p>Use the Test key to perform an ultrasonic test. Test performs a seek and then ramps the amplitude to the current setting.</p>
	<p><b>EtherNet/IP Connectors</b></p> <p>Use the EtherNet/IP Connector to connect the DCX F-EIP Power Supply to a master/slave EtherNet/IP network. For more information, refer to <a href="#">Chapter 5: Installation and Setup</a> and <a href="#">Chapter 7: Operation</a></p>
	<p><b>Ethernet Port</b></p> <p>Use the Ethernet Port to connect to the DCX F-EIP Power Supply Web Page Interface.</p>
	<p><b>Power-On Indicator</b></p> <p>Lights when the power supply is connected to main power and the power switch is on.</p>
	<p><b>24 V Indicator</b></p> <p>Lights when 24 V DC are supplied to the DCX F-EIP Power Supply.</p>
	<p><b>EtherNet/IP Status Indicator</b></p> <p>Indicate the status of the EtherNet/IP module. For more information see <a href="#">Chapter 7: Operation</a>.</p>

Figure 2.4 LCD Description

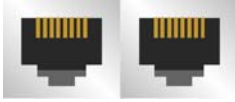
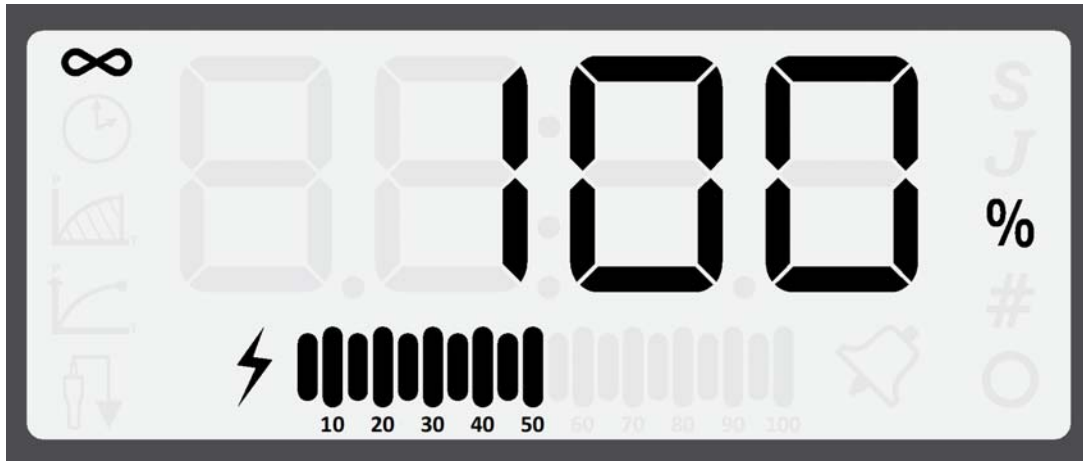

Table 2.4 LCD Description











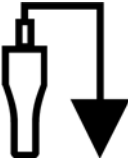

Reference	Description
	<p><b>Numeric Display</b></p> <p>Displays the Power Supply amplitude settings, weld time settings, weld energy settings, peak power settings, scrub time settings, register numbers, register values or alarm numbers.</p>
	<p><b>Continuous Mode Icon</b></p> <p>Indicates the power supply is running in Continuous mode. When in Continuous mode, the amplitude setting is shown on the numeric display in conjunction with the % icon. The amplitude setting may range from 10% to 100%. For more information see <a href="#">Chapter 7: Operation</a>.</p>
	<p><b>Time Mode Icon</b></p> <p>Indicates the power supply is running in Time mode. When in Time mode, the weld time setting is shown on the numeric display in conjunction with the S icon. The weld time setting can range from 10 ms to 30 seconds. For more information see <a href="#">Chapter 7: Operation</a>.</p>
	<p><b>Energy Mode Icon</b></p> <p>Indicates the power supply is running in Energy mode. When in Energy mode, the weld energy setting is shown on the numeric display in conjunction with the J icon. The energy setting may range from 1 Joule to 9999 Joules. For more information see <a href="#">Chapter 7: Operation</a>.</p>

Table 2.4 LCD Description

Reference	Description
	<p><b>Peak Power Icon</b></p> <p>Indicates the power supply is running in Peak Power mode. When in Peak Power mode, the peak power percentage is shown on the numeric display in conjunction with the % icon. The peak power setting may range from 1% to 100% of the maximum power supply output power. For more information see <a href="#">Chapter 7: Operation</a>.</p>
	<p><b>Ground Detect Icon</b></p> <p>Indicates the power supply is running in Ground Detect mode. When in Ground Detect mode, the scrub time setting will be shown on the numeric display in conjunction with the S icon. Scrub time setting may range from 1 millisecond to 500 milliseconds. For more information see <a href="#">Chapter 7: Operation</a>.</p>
	<p><b>Sonics Active Indicator</b></p> <p>Indicates ultrasonics is running.</p>
	<p><b>Time Icon</b></p> <p>Indicates that the value shown on the numeric display represents time in seconds.</p>
	<p><b>Joule Icon</b></p> <p>Indicates that the value shown on the numeric display represents energy.</p>
	<p><b>Percentage Icon</b></p> <p>Indicates that the value shown on the numeric display represents a percentage. When in Peak Power mode, the value shown on the numeric display represents a percentage of the power supply rated power. If not in Peak Power mode, the value shown on the numeric represents the amplitude setting.</p>
	<p><b>Number Sign Icon</b></p> <p>Indicates that the value shown on the numeric display is a register number. Use up and down keys to select a register. For more information see <a href="#">7.4 Configuring the Power Supply Registers</a>.</p>

**Table 2.4** LCD Description

Reference	Description
	<p><b>Circle Icon</b></p> <p>Indicates that the value shown on the numeric display is a register value. Use up and down keys to modify the register value. For more information see <a href="#">7.4 Configuring the Power Supply Registers</a>.</p>
	<p><b>Alarm Icon</b></p> <p>A flashing icon which indicates and alarm condition.</p>
	<p><b>Power/Frequency Bar-Graph</b></p> <p>Shows the true percentage of ultrasonic power during a weld cycle. The bar-graph can be configured to show the peak power or the memory frequency at the end of each weld or test cycle. For instructions on how to modify this setting see <a href="#">7.4 Configuring the Power Supply Registers</a>.</p> <p>For detailed bar-graph description and bar-graph reading examples, see <a href="#">7.5.2 Frequency Bar-Graph Interpretation</a>.</p>

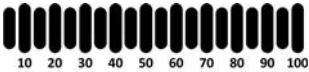
## 2.4.2 DCX F-EIP Power Supply Connections

**Figure 2.5** DCX F-EIP Power Supply Back Panel (Horizontal)



**Figure 2.6** DCX F-EIP Power Supply Bottom Panel (Vertical)

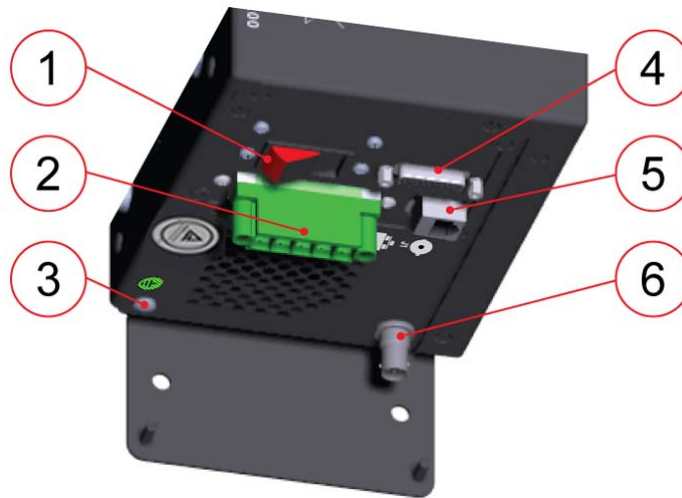

**Table 2.5** Connections to the DCX F-EIP Power Supply

Item	Name	Function
1	Circuit Breaker / Power Switch	Turns the AC main power on or off.
2	Line Input Connector	Detachable connector block for connecting the input power. For wiring details refer to <a href="#">Chapter 5: Installation and Setup</a> .
3	Ground Screw	Ground screw to serve as a redundant safety measure.
4	User I/O Connector	Provides the necessary input/output signals to interface with actuators, user automation or control interfaces. For detailed information on interfacing with the DCX F-EIP Power Supply refer to <a href="#">Chapter 5: Installation and Setup</a> .
5	Ethernet Port	Use the Ethernet Port to connect to the DCX F-EIP Power Supply Web Page Interface.
6	RF Connector	SHV connector for RF cable, which provides ultrasonic energy to the converter.

## 2.5 Welding Systems

### 2.5.1 Principle of Operation

Thermoplastic parts are welded ultrasonically by applying high frequency vibrations to the parts being assembled. The vibrations, through surface and intermolecular friction, produce a sharp rise in temperature at the welding interface.

When the temperature is high enough to melt the plastic, there is a flow of material between the parts. When the vibrations stop, the material solidifies under pressure and a weld results.

### 2.5.2 Weld System Applications

DCX F-EIP Power Supply weld systems can be used for the following applications:

- Ultrasonic welding
- Cutting and sealing thermoplastic fabric and film
- Staking, spot welding, swaging, and degating thermoplastic parts
- Other ultrasonic processing applications

## 2.6 Glossary

The following terminology may be encountered when using or operating a DCX F-EIP Power Supply ultrasonic welding system:

- **Actuator:** The unit which houses the converter/booster/horn stack assembly in a rigid mounting, allowing the stack to move up and down, either mechanically or pneumatically, applying force to the part at a user-adjustable force and velocity
- **Alarm:** Visual indication of error
- **Amplitude Control:** The ability to set amplitude digitally or by an external control
- **Amplitude:** The peak-to-peak movement at the horn face. Always expressed as a percentage of the maximum
- **Booster:** A one-half-wavelength-long resonant metal section mounted between the converter and horn, sometimes having a change in cross-sectional area between the input and output surfaces. The booster mechanically alters the amplitude of vibrations received from the converter, and imparts the new amplitude to the horn
- **Clamping Force:** The pounds or kilograms exerted by the horn onto the workpiece
- **Cold Start:** Restores the settings of the power supply back to its original condition
- **Converter:** The device that converts electrical energy into mechanical vibrations at a high frequency (an ultrasonic rate)
- **Counters:** A record of the number of preset cycles recorded in the power supply
- **Degating:** Removing a molded part from its runner system
- **Energy Director:** A triangular-shaped projection of plastic material which concentrates the ultrasonic energy at the joint interface of a plastic part
- **EtherNet/IP (Ethernet Industrial Protocol):** A communications protocol designed for use in process control and industrial automation applications
- **External Amplitude Control:** Enables you to access real-time amplitude control directly via the user I/O connector
- **External Frequency Control:** Enables you to access real-time frequency offset control directly via the user I/O connector
- **Fieldbus:** Computer network protocols for industrial two way communications used for real-time distributed control
- **Fixture:** A device for holding a part in position for assembly
- **Flash:** Material displaced from the joint area
- **Forming:** Reshaping a section of thermoplastic
- **Fretting Corrosion:** A black surface condition, that results from friction between metal parts, that appears on the converter-booster-horn stack mating surfaces
- **Frequency:** The operating frequency of the ultrasonic stack. The frequency stored is measured at the end of the ultrasonic portion of the cycle (when ultrasonics are terminated)
- **Frequency Offset:** An offset factor applied to the ultrasonic frequency stored in the power supply
- **Gain:** The ratio of output to input amplitude of a horn or booster
- **Horn:** A bar or metal section, usually one half-wavelength-long which transfers vibratory energy to the workpiece
- **Horn Amplitude:** The peak-to-peak displacement of a horn at its work face
- **Horn Signature:** A scan to enhance selection of operating frequency and control parameters
- **Insertion:** The process of embedding a metal component in plastic
- **Interface:** 1. The contact surface of two mating parts. 2. The connection between two pieces of equipment
- **Joint:** The weld surfaces
- **Parameter:** A unique factor or element which affects the welding operation in a particular mode
- **Parameter Range:** Valid range of parameters accepted for a particular setup

- **Power Supply:** The electronic instrument in an ultrasonic assembly system which changes conventional 50/60 Hz electrical power into high frequency electrical power at 20 kHz, 30 kHz or 40 kHz
- **Seek:** The activation of ultrasonics at a low-level (10 %) amplitude, for the purpose of finding the resonant frequency of the stack
- **Staking:** The process of melting and reforming a plastic stud to mechanically lock a dissimilar material in place
- **Swaging:** The process of capturing another component of an assembly by melting and reforming a ridge of plastic
- **Thermoplastic:** A polymer which undergoes a reversible change of state when subjected to heat
- **Thermoset:** A polymer which undergoes an irreversible change when subjected to heat
- **Token:** Token is a concept that applies to who can make a change to the preset. If the fieldbus has gotten the token, then only the fieldbus can perform a change. However, if fieldbus has not gotten the token (or has released the token), then the preset can be changed by any other means, for example, via Web Page or front panel controls
- **Ultrasonic Power:** Presence of ultrasonic power at the horn face
- **Ultrasonic Welding:** The use of ultrasonic vibrations to generate heat and subsequently melt the mating surfaces of two thermoplastic parts. When ultrasonic vibrations stop, the molten material resolidifies, and a weld occurs
- **User ID:** A unique 12 character long alphanumeric ID used to keep track of user access to the web page interface
- **Weld System:** A combination of components required to perform an ultrasonic operation. Usually consists of a power supply, converter, booster, and horn, with either an actuator or a handheld device, or in a fixed, mounted location



---

## Chapter 3: Delivery and Handling

---

<b>3.1</b>	<b>Shipping and Handling</b> . . . . .	<b>30</b>
<b>3.2</b>	<b>Receiving</b> . . . . .	<b>31</b>
<b>3.3</b>	<b>Unpacking the Power Supply</b> . . . . .	<b>32</b>
<b>3.4</b>	<b>Take Inventory of Small Parts</b> . . . . .	<b>33</b>
<b>3.5</b>	<b>Returning Equipment</b> . . . . .	<b>34</b>

## 3.1 Shipping and Handling

CAUTION	Heavy Object
	<p>The power supply may be heavy. Handling, unpacking, and installation may require the assistance of a colleague or the use of lifting platforms or hoists.</p>

### 3.1.1 Environmental Specifications

The DCX F-EIP Power Supply is an electronic unit that converts line voltage to ultrasonic energy and responds to user input for regulating the weld process. Its internal components are sensitive to static discharge, and many of its components can be harmed if the unit is dropped, shipped under improper conditions, or otherwise mishandled.

The following environmental guidelines should be respected in the shipping of the power supply.

**Table 3.1** Shipping Specifications

Environmental Condition	Acceptable Range
Storage / Shipping Temperature	-25° C / -13° F to +55° C / +131° F (+70° C / +158° F for 24 hours)
Shock / Vibration (transit)	45 g shock / 0.5 g and (3 to 100 Hz) vibration per ASTM 3332-88 and 3580-90
Drop Test	ISTA Procedure 1 & 2A (while packaged)
Humidity	Maximum 95%, non-condensing

## 3.2 Receiving

The DCX F-EIP Power Supply is a sensitive electronic device. Many of its components can be harmed if the unit is dropped or otherwise mishandled.

### Scope of Delivery

Branson equipment is carefully checked and packed before dispatch. It is recommended, however, that you follow the procedure below upon receiving your DCX F-EIP Power Supply.

**Inspect the Power Supply when it is delivered, take the following steps.**

**Table 3.2** Inspect the Power Supply

Step	Action
1	Verify that all parts are complete according to the packing slip.
2	Check the packing and the unit for damage (visual inspection).
3	Report any damage claims to your carrier immediately.
4	Determine if any component has become loose during shipping and, if necessary, tighten screws.

NOTICE	
	<p>If the goods delivered have been damaged during shipping, please contact the forwarding agent immediately. Retain packing material (for possible inspection or for sending back the unit).</p>

## 3.3 Unpacking the Power Supply

NOTICE	
	<p>If there are any visible signs of damage to the shipping containers or the product, or you later discover hidden damage, NOTIFY YOUR CARRIER IMMEDIATELY. Save the packing material.</p>

The power supply is fully assembled. It is shipped in a sturdy cardboard box. Some additional items are shipped in the box with the power supply. Note orientation of packaging material in case return/repack is necessary. When unpacking the power supply, take the following steps:

**Table 3.3** Unpacking the Power Supply

Step	Action
1	Unpack the power supply as soon as it arrives. Save the packing material
2	Verify you have all of the equipment ordered. Some components are packed inside other boxes.
3	Inspect the controls, indicators, and surface for signs of damage.
4	Remove the cover of the power supply to check if any components became loose during shipping.

## 3.4 Take Inventory of Small Parts

**Table 3.4** Small Parts included: Power Supply Assemblies

Part or Kit	20 kHz	30 kHz	40 kHz
Mylar®* plastic film Washer Kit	X	X	
Silicone Grease			X
Spanners (2)	X	X	X

\* Mylar is a registered trademark of DuPont Teijin Films.

### 3.4.1 Cables

The RF cable connects the power supply to the converter. For automated systems you will also need a user I/O cable to monitor and control the power supply. Check your invoice for cable types and cable lengths.

**Table 3.5** DCX F-EIP Power Supply System Cables

P/N	Description
100-240-383	Cable, RF 8 ft (2.5 m)
100-240-384	Cable, RF 15 ft (4.5 m)
100-240-385	Cable, RF 25 ft (7.5 m)
100-240-387	Cable, RF right angle 8 ft (2.5 m)
100-240-388	Cable, RF right angle 15 ft (4.5 m)
100-240-389	Cable, RF right angle 25 ft (7.5 m)
100-240-391	Cable, RF adaptor for CR20 converter 3 ft (0.9 m)
100-240-392	Cable, User I/O 25 ft (7.5 m)
100-240-393	Cable, User I/O 50 ft (15 m)
200-240-396	Cable Ethernet Cat 5e 7 ft (2.1 m)
100-240-397	Cable, RF adaptor for 4TR converter 3 ft (0.9 m)

## 3.5 Returning Equipment

If you are returning equipment to Branson Ultrasonic Corporation, please call your Customer Service Representative to receive approval to return the goods. Refer to [1.4 How to Contact Branson](#).

---

## Chapter 4: Technical Specifications

---

4.1	Technical Specifications . . . . .	36
4.2	Physical Description . . . . .	39
4.3	EU Declaration of Conformity . . . . .	40
4.4	UK Declaration of Conformity . . . . .	41
4.5	Declaration of Conformity to the EtherNet/IP Specification . . . . .	42

## 4.1 Technical Specifications

NOTICE	
	All specifications are subject to change without notice.

### 4.1.1 Environmental Specifications

The DCX F-EIP Power Supply has the following environmental specifications:

**Table 4.1** Environmental Specifications

Environmental Condition	Acceptable Range
Ambient Operating Temperature	+41° F to +104° F (+5° C to +40° C)
Storage / Shipping Temperature	-13° F to +131° F (-25° C to +55° C)
Humidity	Maximum 95%, non-condensing
IP Rating	2X
Altitude	Up to 3280ft (1000m)
Pollution degree	2
Overvoltage category	II

NOTICE	
	Cooling fan is the thermostat controller.

### 4.1.2 Electrical Specifications

The following tables list input voltage and current requirements for the DCX F-EIP Power Supply.



## Electrical Input Operating Voltages

**Table 4.2** Electrical Input Operating Voltages

Power Supply Rating	Input Operating Voltage
All Models	200 V to 240 V Nominal (180 V Min.* to 253 V Max.), 50 Hz or 60 Hz, Single Phase
	24 VDC, 2.5 A

\* 200 V Min. for 4 kW units.

## Input Current and Circuit Breaker Specifications

**Table 4.3** Input Current and Circuit Breaker Specifications

Model	Power	Current Rating
20 kHz	1250 W	7 A Max. @ 200 - 240 V / 15 A Breaker
	2500 W	14 A Max. @ 200 - 240 V / 25 A Breaker
	4000 W	25 A Max. @ 200 - 240 V / 25 A Breaker
30 kHz	750 W	5 A Max. @ 200 - 240 V / 10 A Breaker
	1500 W	10 A Max. @ 200 - 240 V / 15 A Breaker
40 kHz	400 W	3 A Max. @ 200 - 240 V / 10 A Breaker
	800 W	5 A Max. @ 200 - 240 V / 10 A Breaker

## Continuous Duty Maximum Power

**Table 4.4** Continuous Duty Maximum Power

Model	Power	Continuous Duty Max. Power
20 kHz	1250 W	800 W
	2500 W	1600 W
	4000 W	2000 W
30 kHz	750 W	300 W
	1500 W	800 W
40 kHz	400 W	300 W
	800 W	400 W

NOTICE	
	<p>High duty cycles require additional cooling for the converter. For information on converter cooling refer to <a href="#">5.6 Converter Cooling</a> in <a href="#">Chapter 5: Installation and Setup</a>.</p>

NOTICE	
	<p>System average power must be limited to the specified continuous maximum. Higher peak power, up to the maximum acceptable power limit, with an on time of up to 10 seconds may be obtained if appropriate off time ensures that, on average, the Continuous Duty Maximum Power is not exceeded.</p>

Cycle Rate – up to 200 cpm. Cycle rate including off time is application and stack dependent.

## 4.2 Physical Description

This section describes the physical dimensions of the DCX F-EIP Power Supply.

NOTICE	
	Dimensions are nominal.

**Table 4.5** DCX F-EIP Power Supply

Size	Width	Height	Depth	Weight
Small (Benchtop)	14" 356 mm	5.5" 132 mm	7.4" 187 mm	16 lb 7.2 kg
Small (Vertical)	5.2" 132 mm	14" 356 mm		
Medium (Benchtop)	14" 356 mm	5.5" 132 mm	8.6" 219 mm	18 lb 8.2 kg
Medium (Vertical)	5.2" 132 mm	14" 356 mm		
Large (Benchtop)	14" 356 mm	5.5" 132 mm	10.6" 270 mm	22 lb 10 kg
Large (Vertical)	5.2" 132 mm	14" 356 mm		

For detailed dimensional information refer to [Chapter 5: Installation and Setup](#).

## 4.3 EU Declaration of Conformity

Figure 4.1 EU Declaration of Conformity

DocuSign Envelope ID: B0909E8A-D9E3-4295-81B6-06331CD21321

**EU DECLARATION OF CONFORMITY**  
According to Low Voltage Directive 2014/35/EU,  
EMC Directive 2014/30/EU,  
and RoHS Directive 2011/65/EU.



We, the manufacturer

**BRANSON ULTRASONICS CORPORATION**  
120 Park Ridge Rd  
Brookfield, CT 06804  
USA

represented in the community by

BRANSON ULTRASONICS, a.s.  
Piestanska 1202  
91501 Nove Mesto nad Vahom  
Slovak Republic

expressly declare under our sole responsibility that the following electrical equipment product:

Ultrasonic Assembly System consisting of an Ultrasonic Power Supply, model:

0.40DCX(s, v, a, f-dp or f-eip)40(VRT, V, H or HOR)  
0.80DCX(s, v, a, f-dp or f-eip)40(VRT, V, H or HOR)  
0.75DCX(s, v, a, f-dp or f-eip)30(VRT, V, H or HOR)  
1.50DCX(s, v, a, f-dp or f-eip)30(VRT, V, H or HOR)  
1.25DCX(s, v, a, f-dp or f-eip)20(VRT, V, H or HOR)  
2.50DCX(S+, s, v, a, f-dp or f-eip)20(VRT, V, H or HOR)  
4.00DCX(S+, s, v, a, f-dp or f-eip)20(VRT, V, H or HOR)  
4.00DCXs20HD -V  
P/S 0.8 DCX S HD 40 VRT  
1.50 DCX-S HD 30 HOR  
1.50 DCX-S HD 30 VRT  
4.00DCXs20HD -H  
P/S 0.8 DCX S HD 40 HOR  
P/S 4.0KW 20KHZ DCX S LIM RES

used with converter model: CR-20, CR-20S, CR-20C, CH-20C, CS-20S, CS-20C, CR-30, CR-30C, CH-30, CH-30C, CS-30S, CS-30C, CR-40C, 4TR, 4TH, 4TP or 932, and associated cables.

in the state in which it was placed on the market, fulfills all the relevant provisions of:

Low Voltage Directive **2014/35/EU**  
EMC Directive **2014/30/EU**  
RoHS Directive **2011/65/EU**

The object of this declaration is in conformity with relevant Union harmonization legislation. The electrical equipment product, to which this declaration relates, is in conformity with the following standards:

EN 61010-1:2010+A1:2019  
EN 55011:2016/A11:2020  
EN 61000-6-2:2005/AC:2005

Brookfield, CT, USA  
March 29, 2022

DocuSigned by:  
*Luis Benavides*  
018235BF CDE147C...  
Luis Benavides  
Product safety Officer

## 4.4 UK Declaration of Conformity

Figure 4.2 UK Declaration of Conformity

DocuSign Envelope ID: CBF9A5E3-CFF5-43C8-B1AA-6F0C89C3A63B



### UK DECLARATION OF CONFORMITY

We, the manufacturer

**BRANSON ULTRASONICS CORPORATION**  
120 Park Ridge Rd.  
Brookfield, CT 06804  
USA

expressly declare under our sole responsibility that the following electrical equipment product:

Ultrasonic Assembly System consisting of an Ultrasonic Power Supply, model:

0.40DCX(s, v, a, f-dp or f-eip)40(VRT, V, H or HOR)  
0.80DCX(s, v, a, f-dp or f-eip)40(VRT, V, H or HOR)  
0.75DCX(s, v, a, f-dp or f-eip)30(VRT, V, H or HOR)  
1.50DCX(s, v, a, f-dp or f-eip)30(VRT, V, H or HOR)  
1.25DCX(s, v, a, f-dp or f-eip)20(VRT, V, H or HOR)  
2.50DCX(S+, s, v, a, f-dp or f-eip)20(VRT, V, H or HOR)  
4.00DCX(S+, s, v, a, f-dp or f-eip)20(VRT, V, H or HOR)  
4.00DCXs20HD -V  
P/S 0.8 DCX S HD 40 VRT  
1.50 DCX-S HD 30 HOR  
1.50 DCX-S HD 30 VRT  
4.00DCXs20HD -H  
P/S 0.8 DCX S HD 40 HOR  
P/S 4.0KW 20KHZ DCX S LIM RES

used with converter model: CR-20, CR-20S, CR-20C, CH-20C, CS-20S, CS-20C, CR-30, CR-30C, CH-30, CH-30C, CS-30S, CS-30C, CR-40C, 4TR, 4TH, 4TP or 932, and associated cables.

in the state in which it was placed on the market, fulfills all the relevant provisions of:

Electrical Equipment (Safety) Regulations **2016**  
Electromagnetic Compatibility Regulations **2016**  
Restriction of the Use of Certain Hazardous Substances in Electrical and Electronic Equipment Regulations **2012**.

The electrical equipment product, to which this declaration relates, is in conformity with the following designated standards:

BS EN 61010-1:2010+A1:2019  
BS EN 55011:2016/A11:2020  
BS EN 61000-6-2:2005/AC:2005

Brookfield, CT, USA  
March 22, 2022

DocuSigned by:  
*Luis Benavides*  
0182358FCDE147C...  
Luis Benavides  
Product safety Officer

## 4.5 Declaration of Conformity to the EtherNet/IP Specification

Figure 4.3 Declaration of Conformity to the EtherNet/IP Specification



### Declaration of Conformity to the EtherNet/IP™ Specification

ODVA hereby issues this Certificate of Declarations of Conformity to the EtherNet/IP™ Specification for the product(s) described below. The Vendor listed below (the "Vendor") has holds a valid the Terms of Usage Agreement for the EtherNet/IP Technology from ODVA, which is incorporated herein by reference, thereby agreeing that it is the Vendor's ultimate responsibility to assure that its EtherNet/IP Compliant Products conform to the EtherNet/IP Specifications and that the EtherNet/IP Specifications are provided by ODVA to the vendor on an AS IS basis without warranty. NO WARRANTIES, EXPRESSED OR IMPLIED, INCLUDING WITHOUT LIMITATION ANY WARRANTIES OF MERCHANTABILITY OR FITNESS FOR A PARTICULAR PURPOSE, ARE BEING PROVIDED BY ODVA.

In recognition of the below EtherNet/IP Compliant Product(s) having been EtherNet/IP Conformance Tested at ODVA-authorized Test Service Provider and having received a passing result from ODVA at the Composite Test Revision Level specified below, this Declaration of Conformity authorizes the Vendor to use the EtherNet/IP Certification Marks in conjunction with the specific EtherNet/IP Compliant Product(s) described below, for so long as the Vendor's Terms of Usage Agreement for the EtherNet/IP Technology remains valid.



EtherNet/IP CONFORMANCE TESTED™

Certification Logo Mark

Certification Word Mark

This Certificate is issued on **January 15, 2014** on behalf of ODVA by:

Katherine Voss  
Executive Director

Test Information				
Vendor Name		Branson Ultrasonics		
Test Information				
Test Date		January 10, 2014		
Composite Test Revision		CT10		
ODVA File Number		11245.02		
Product Information				
Identity Object Instance				
Vendor ID (Attribute 1)		1283		
Device Type (Attribute 2)		0x2B		
Device Profile Name		Generic Device (keyable)		
Products Covered under this Declaration of Conformity (Identity Object Instance)				
No.	Product Code (Attribute 3)	Product Name (Attribute 7)	Product Revision (Attribute 4)	SOC File Name
1	2	DCX-FE	2.001	DCX_STC

EtherNet/IP and EtherNet/IP CONFORMANCE TESTED logo mark and word mark are trademarks of ODVA.

---

## Chapter 5: Installation and Setup

---

5.1	About Installation. . . . .	44
5.2	Installation Requirements . . . . .	45
5.3	Installation Steps . . . . .	51
5.4	Power Supply Setup . . . . .	74
5.5	Assembling the Acoustic Stack. . . . .	75
5.6	Converter Cooling. . . . .	80
5.7	Testing the Installation . . . . .	82
5.8	Still Need Help? . . . . .	83

## 5.1 About Installation

This chapter is intended to help the installer with the basic installation and setup of your new DCX F-EIP Power Supply.

CAUTION	Heavy Object
	The power supply, and related components are heavy. Handling, unpacking, and installation may require the assistance of a colleague or the use of lifting platforms or hoists.

International safety-related labels are found on the power supply. Those that are of importance during installation of the system are identified in [Figure 1.1 Safety-related Labels found on the DCX F-EIP Power Supply](#).



## 5.2 Installation Requirements

This section covers the location requirements, mounting options, power supply dimensions, environmental requirements, and electrical requirements, to help you plan and execute your installation successfully.

### 5.2.1 EtherNet/IP Wiring Considerations

It is recommended to use as a minimum Cat5 Ethernet cable on new installations with a maximum cable length of 100 m (328 ft). If existing cabling is of lower category, maximum data rate may be limited.

### 5.2.2 Location

The DCX F-EIP Power Supply comes in two different models Horizontal (benchtop) and Vertical (which may be back mounted or side mounted).

The power supply should be accessible for parameter changes and settings, and it can be placed in a horizontal or vertical orientation (depending on your selected model). The power supply should be located in an area away from radiators or heating vents and positioned so it does not draw in dust, dirt or material via its cooling fan.

The DCX F-EIP Power Supply must not be positioned so that is difficult to plug in or unplug the main power plug.

A cable clamp can be used to secure wires in place.

NOTICE	
	Cable clamp is not included with the unit.

Refer to the illustrations on the pages that follow for dimensional drawings of both models. All dimensions are approximate and may vary slightly:

[Figure 5.1 DCX F-EIP Power Supply Benchtop Dimensional Drawing.](#)

[Figure 5.2 DCX F-EIP Power Supply Vertical Mount dimensional drawing \(400 W, 750 W & 800 W\).](#)

[Figure 5.3 DCX F-EIP Power Supply Vertical Mount dimensional drawing \(1.25 kW and 1.5 kW\).](#)

[Figure 5.4 DCX F-EIP Power Supply Vertical Mount dimensional drawing \(2.5 kW and 4 kW\).](#)

**Figure 5.1** DCX F-EIP Power Supply Benchtop Dimensional Drawing

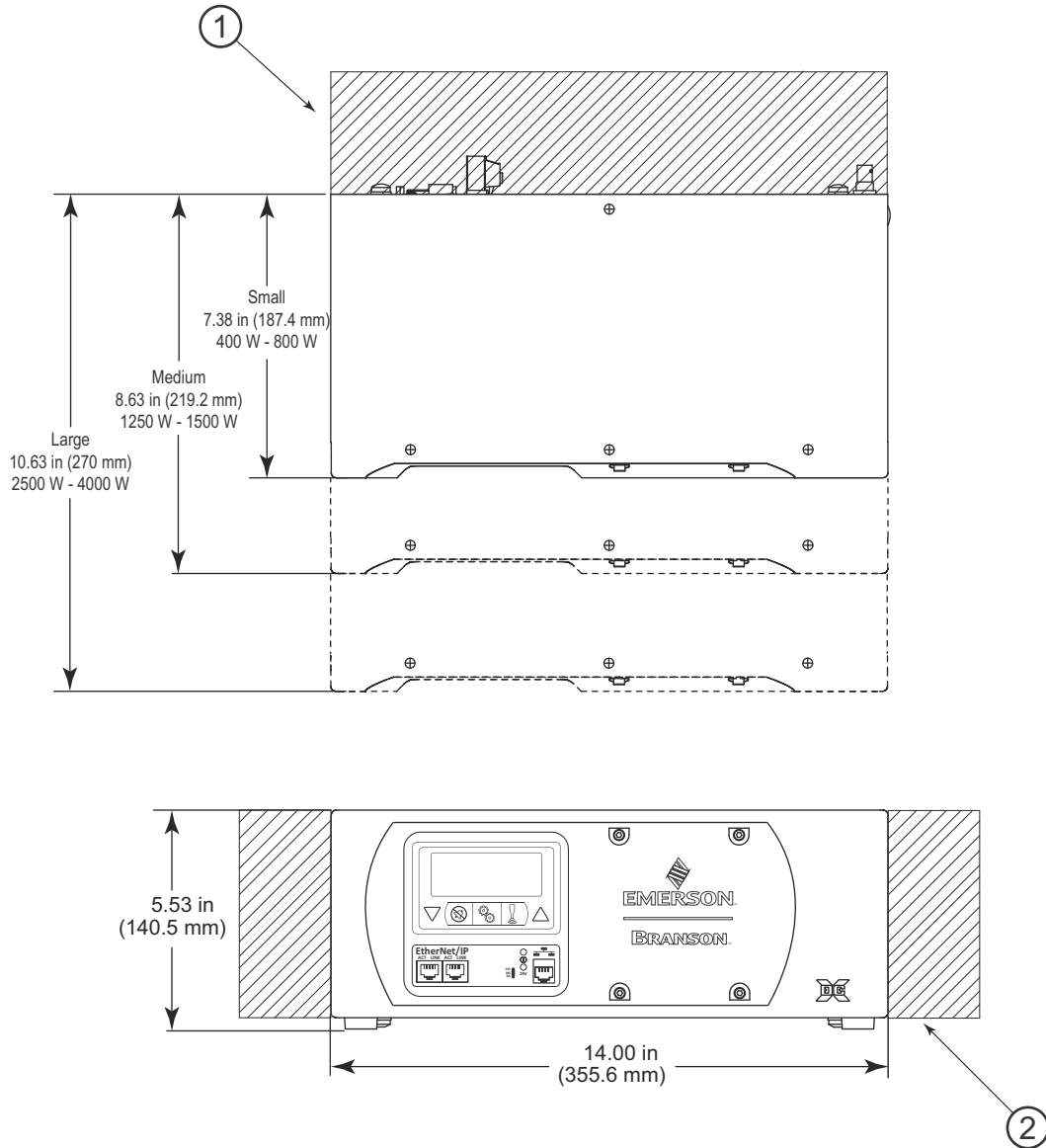

**Table 5.1** DCX F-EIP Power Supply Benchtop Dimensional Drawing

Item	Note
1	5.0 in (127 mm) recommended clearance for cables.
2	3.0 in (76 mm) recommended fan clearance (both sides).

**Figure 5.2** DCX F-EIP Power Supply Vertical Mount dimensional drawing (400 W, 750 W & 800 W)

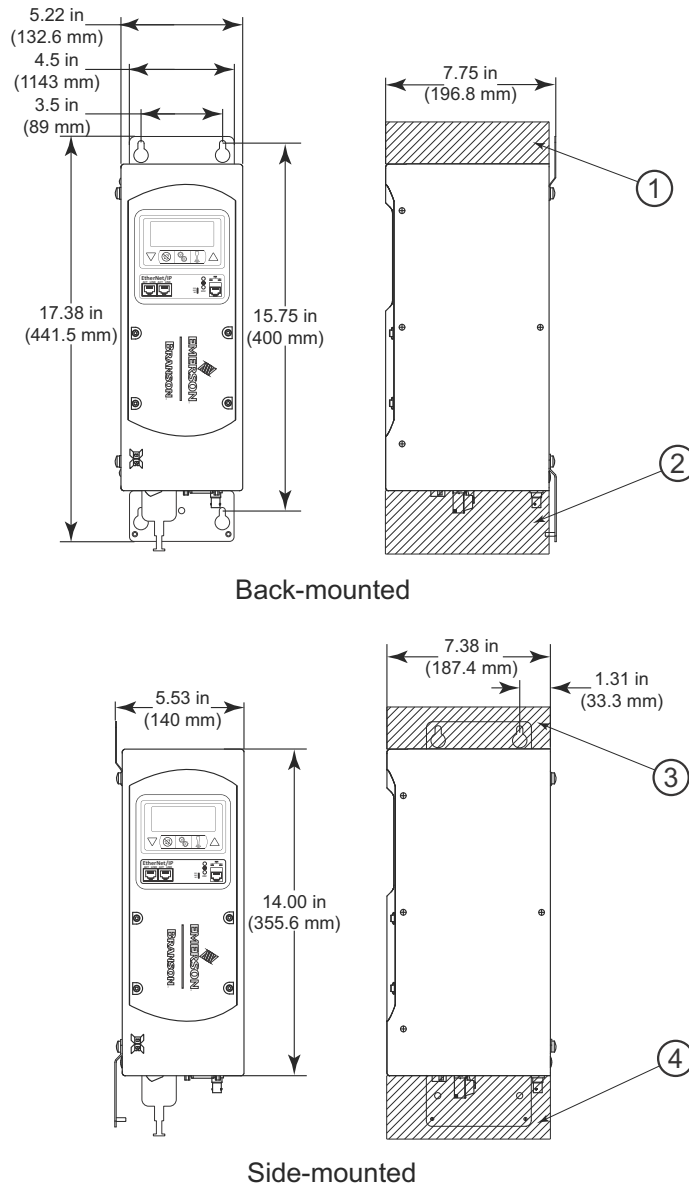
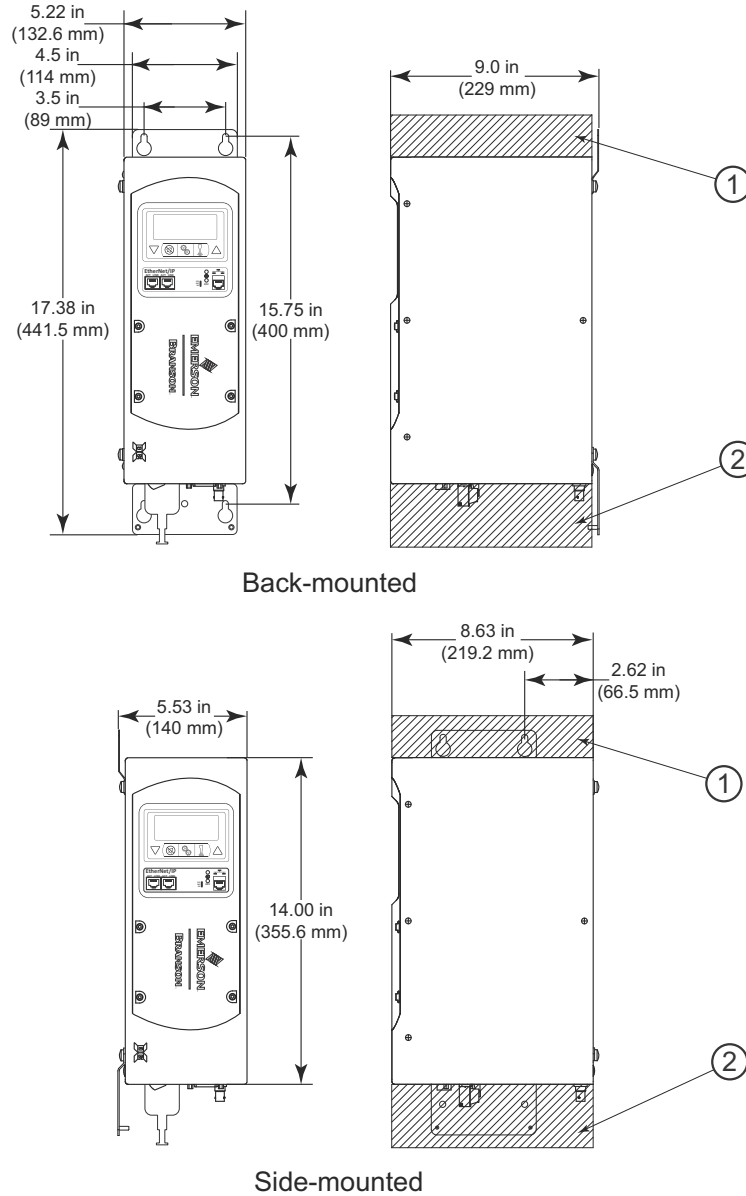

**Table 5.2** DCX F-EIP Power Supply Vertical Mount dimensional drawing (400 W, 750 W & 800 W)

Item	Note
1	3.0 in (76 mm) recommended fan clearance.
2	5.0 in (127 mm) recommended clearance for cables.

<b>NOTICE</b>	
	<p>Use the keyhole mounting bracket to mount the unit in the needed position. Use M6 (6mm) screws to mount the unit.</p>

**Figure 5.3** DCX F-EIP Power Supply Vertical Mount dimensional drawing (1.25 kW and 1.5 kW)

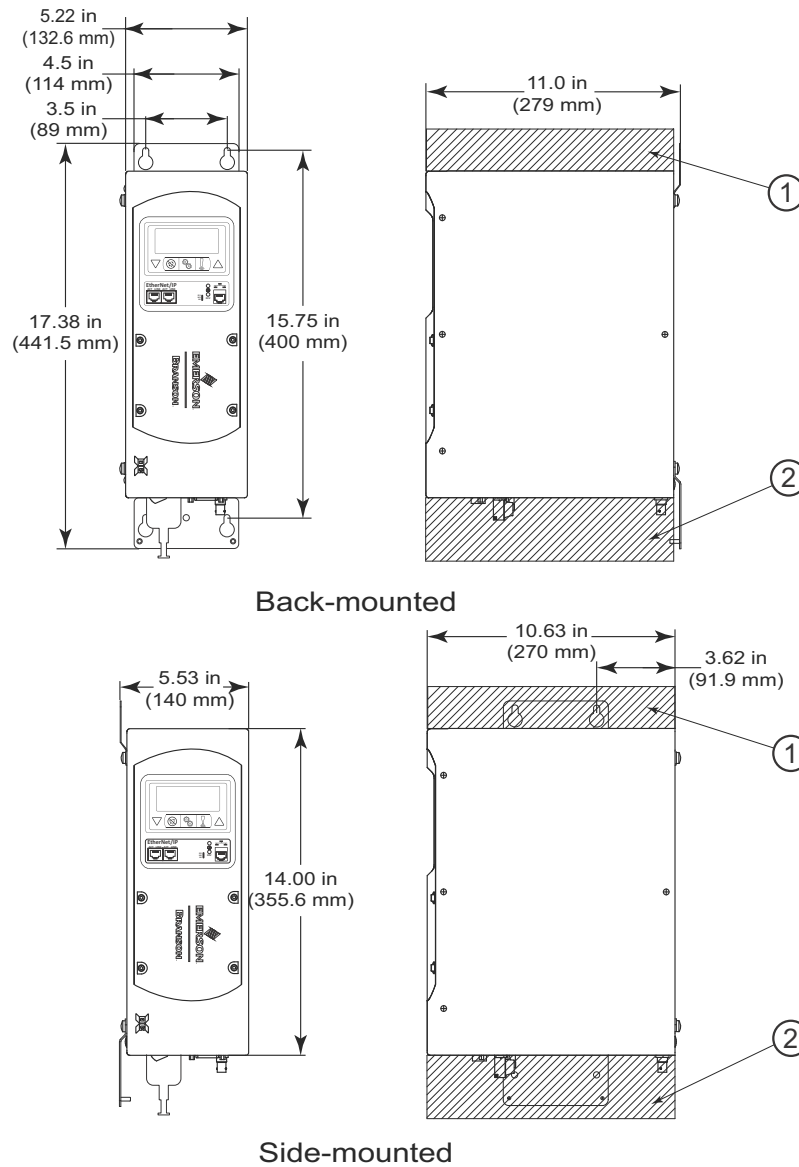

**Table 5.3** DCX F-EIP Power Supply Vertical Mount dimensional drawing (1.25 kW and 1.5 kW)

Item	Note
1	3.0 in (76 mm) recommended fan clearance.
2	5.0 in (127 mm) recommended clearance for cables.

NOTICE	
	<p>Use the keyhole mounting bracket to mount the unit in the needed position. Use M6 (6mm) screws to mount the unit.</p>

**Figure 5.4** DCX F-EIP Power Supply Vertical Mount dimensional drawing (2.5 kW and 4 kW)



**Table 5.4** DCX F-EIP Power Supply Vertical Mount dimensional drawing (2.5 kW and 4 kW)

Item	Note
1	3.0 in (76 mm) recommended fan clearance.
2	5.0 in (127 mm) recommended clearance for cables.

NOTICE	
	<p>Use the keyhole mounting bracket to mount the unit in the needed position. Use M6 (6mm) screws to mount the unit.</p>

## 5.2.3 Environmental Requirements

Verify the DCX F-EIP Power Supply is operated in an environment that meets the temperature and humidity requirements indicated in [Table 5.5 Environmental Requirements](#).

**Table 5.5** Environmental Requirements

Environmental Condition	Acceptable Range
Ambient Operating Temperature	+41° F to +104° F (+5° C to +40° C)
Humidity	Maximum 95%, non-condensing
IP Rating	2X
Altitude	Up to 3280ft (1000m)
Pollution degree	2
Overtoltage category	II

## 5.2.4 Electrical Input Power Ratings

Connect the power supply to a single-phase, grounded, 3-wire, 50 Hz or 60 Hz 200 V to 240 V power source. [Table 5.6 Input Current and Circuit Breaker Specifications](#) lists the current and breaker ratings for the various models.

**Table 5.6** Input Current and Circuit Breaker Specifications

Model	Power	Current Rating
20 kHz	1250 W	7 A Max. @ 200 - 240 V / 15 A Breaker
	2500 W	14 A Max. @ 200 - 240 V / 25 A Breaker
	4000 W	25 A Max. @ 200 - 240 V / 25 A Breaker
30 kHz	750 W	5 A Max. @ 200 - 240 V / 10 A Breaker
	1500 W	10 A Max. @ 200 - 240 V / 15 A Breaker
40 kHz	400 W	3 A Max. @ 200 - 240 V / 10 A Breaker
	800 W	5 A Max. @ 200 - 240 V / 10 A Breaker

## 5.2.5 Pneumatic Requirements

Your welding system may require a cooling air stream for the converters. In continuous operations, or applications with longer duty cycles, it may be necessary to cool the horn as well as the converter.

Typically 80 cubic feet (2.26 m<sup>3</sup>) per hour of clean, dry, compressed air are required to cool most welding operations.

To verify the 80 cubic feet (2.26 m<sup>3</sup>) per hour cooling air stream required for your welding system, refer to [5.6 Converter Cooling](#).

## 5.3 Installation Steps

WARNING	High Voltage Hazard
	<p>To prevent the possibility of an electrical shock:</p> <ul style="list-style-type: none"> <li>• Ensure the power source is disconnected before beginning work on line connections</li> <li>• Ensure the power switch on the back of the unit is in the OFF position before making any electrical connections</li> <li>• Always plug the power supply into a grounded power source</li> <li>• To prevent the possibility of an electrical shock, ground the power supply by securing an 8 gauge grounded conductor to the ground screw located next to the air outlet</li> <li>• Ensure power supply installation is performed by qualified personnel and in accordance with local standards and regulations</li> </ul>

All persons who are involved with installation, commissioning, operation and maintenance must have the required qualification, strictly follow this operating manual.

### Basic installation notes:

- To avoid problems associated with EMI, you should route high power lines (AC and Ultrasonic RF) away from low power lines (controls signals)
- You should consider future troubleshooting and repair when installing all wiring. All wiring should be either color coded or tagged with industrial wire tags
- The minimum cable bend radius is 5 times the cable outer diameter for RF cables
- The minimum cable bend radius is 10 times the cable outer diameter for user I/O & Ethernet cables
- Ground wires should not be shared with other equipment
- All inductive coils must be suppressed with appropriate devices, such as diodes or RC networks

## 5.3.1 Mount the Power Supply

The cable lengths are limited based on the operating frequency of the welding system. Performance and results can suffer if the RF cable is crushed, pinched, damaged or modified. Contact your Branson Representative if you have special cable requirements.

Do not place the power supply on the floor or in other locations that will allow dust, dirt or contaminants to be drawn into the power supply.

NOTICE	
	<p>Special fan filter kits are available for use in dusty environments. See <a href="#">Table 9.12 Other Items used with the DCX F-EIP Power Supply</a>.</p>

NOTICE	
	<p>Do not block exhaust and intake air circulation, which is needed to maintain a safe operating temperature.</p>

## 5.3.2 Horizontal (Benchtop) Mounting

The Horizontal DCX F-EIP Power Supply is designed to be placed on a workbench (rubber feet on bottom) within cable-length limits of the stack. It has one fan which draws cooling air from the left side to the right side, which must be free from obstruction. The controls on the front of the power supply should be accessible and readable for setup changes.

All electrical connections are made to the rear of the power supply, which should be positioned in your workspace with adequate clearance, approximately 3 in (76.2 mm) or more on either side, and 5 in (127 mm) to the rear) for cable access and ventilation. Do not place anything on top of the power supply case.

For a dimensional drawing of the Horizontal DCX F-EIP Power Supply, see [Figure 5.1 DCX F-EIP Power Supply Benchtop Dimensional Drawing](#).

## 5.3.3 Vertical Mounting

The Vertical DCX F-EIP Power Supply is designed to be mounted vertically (from the side or back) within cable-length limits of the stack. It has one fan which draws cooling air from the top to the bottom of the power supply, which must be free from obstruction. The controls on the front of the power supply should be accessible and readable for setup changes.

All electrical connections are made to the bottom of the power supply, which should be positioned with adequate clearance (approximately 3 in (76.2 mm) or more on the top, and 5 in (127 mm) to the bottom) for cable access and ventilation. Do not place anything on top of the power supply case.

For dimensional drawings of the Vertical DCX F-EIP Power Supply, see [Figure 5.2](#), [Figure 5.3](#) and [Figure 5.4](#).



### 5.3.4 Mounting Considerations

In addition to the considerations mentioned above, the LCD's viewing angle should be taken into account when selecting a location for your DCX F-EIP Power Supply. The LCD is designed to be viewed from the top. Please refer to [Figure 5.5 LCD Viewing Angle](#) below when selecting a location for your DCX F-EIP Power Supply.

**Figure 5.5** LCD Viewing Angle

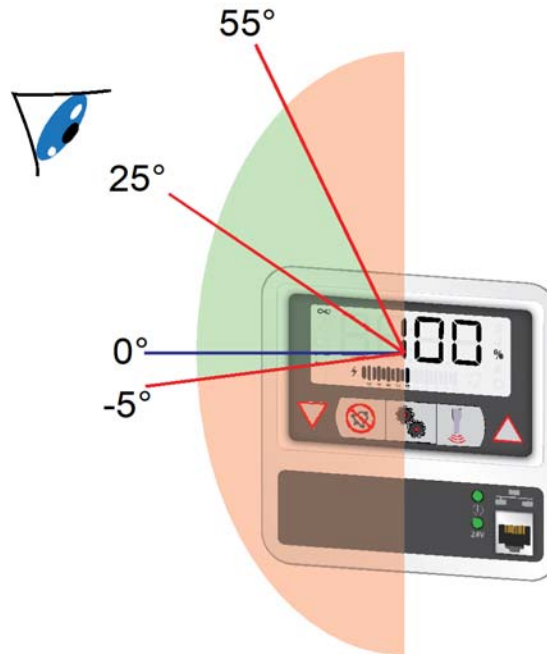

NOTICE	
	<p>Optimal viewing angle is 25° above the normal to the display (indicated by 0°).</p>

## 5.3.5 Electrical Connections

**Figure 5.6** DCX F-EIP Power Supply Connections (Horizontal Model)

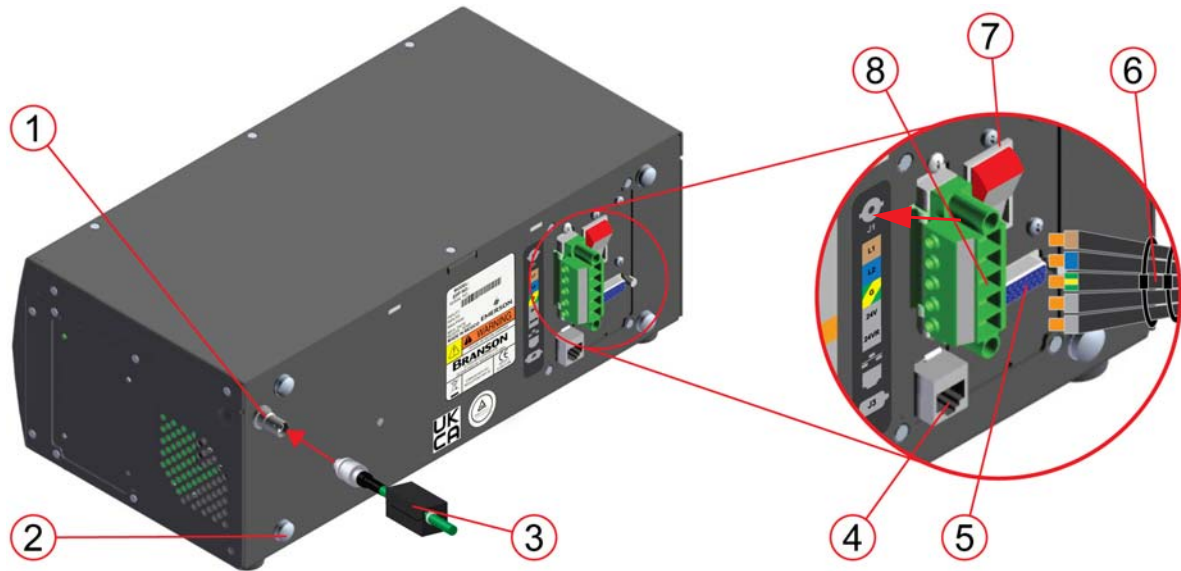

**Table 5.7** DCX F-EIP Power Supply Connections (Horizontal Model)

Item	Description
1	RF Connector
2	Ground Screw
3	RF Cable (Ferrite End)
4	Ethernet Port
5	User I/O Connectors
6	Line Cord
7	Circuit Breaker (On/Off Switch)
8	Input Power Connector

**Figure 5.7** DCX F-EIP Power Supply Connections (Vertical Model)

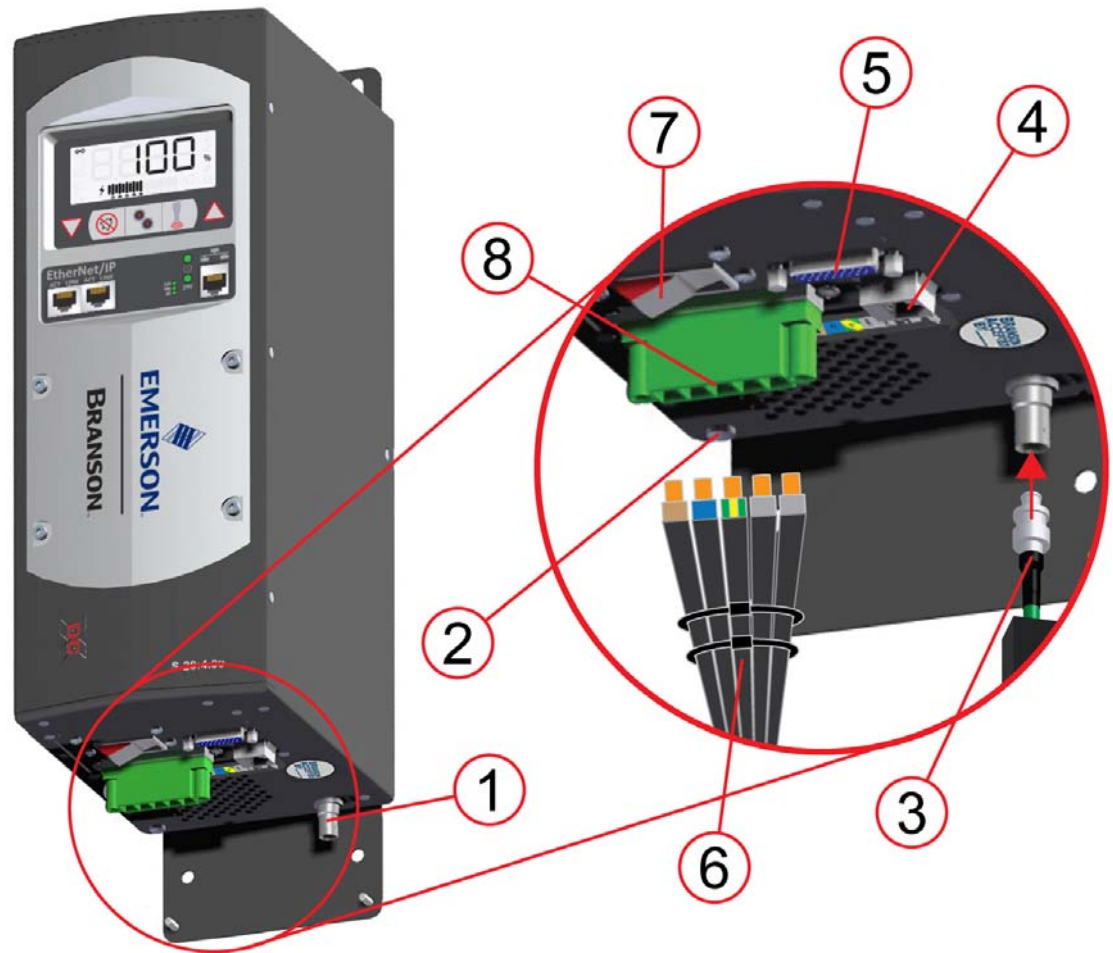

**Table 5.8** DCX F-EIP Power Supply Connections (Vertical Model)

Item	Description
1	RF Connector
2	Ground Screw
3	Line Cord
4	RF Cable (Ferrite End)
5	Ethernet Port
6	User I/O Connectors
7	Circuit Breaker (On/Off Switch)
8	Input Power Connector

## 5.3.6 User I/O Connections

NOTICE	
	User I/O interface is only available in manual mode.

The user I/O is a standard interface for automation, provided on the power supply. It provides the ability to make your own interface for your automation, actuator interface, special control, or reporting needs. The interface cable has a 26-pin HD male D-Sub connector on one end, and wires on the other end. Pins are wired to ICEA standard color code (see [Figure 5.8 User I/O Cable Identification and Wire Color Diagram](#) and [Table 5.10 User I/O Cable Pin Assignments](#)).

NOTICE	
	Ensure all unused wires are properly isolated. Failure to do so may result in a power supply malfunction.

Digital I/O functions can be configured to either active-high or active-low using the DCX F-EIP Power Supply Web Page Interface. [Table 5.11 Digital Input Functions](#) to [Table 5.14 Analog Output Functions](#) list the input and output functions available on the DCX F-EIP Power Supply. See [Table 5.15 Default Branson User I/O Connector PIN Assignments, V6.0](#) for the default user I/O pin assignments.

[Figure 5.9 Typical Digital I/O Wiring Examples](#) and [Figure 5.10 Typical Analog I/O Wiring Examples](#) show typical wiring examples.

**Figure 5.8** User I/O Cable Identification and Wire Color Diagram

User I/O Cable  
 Stripped Jacket one end,  
 HD-26 male connector other end  
 (cable length as ordered)

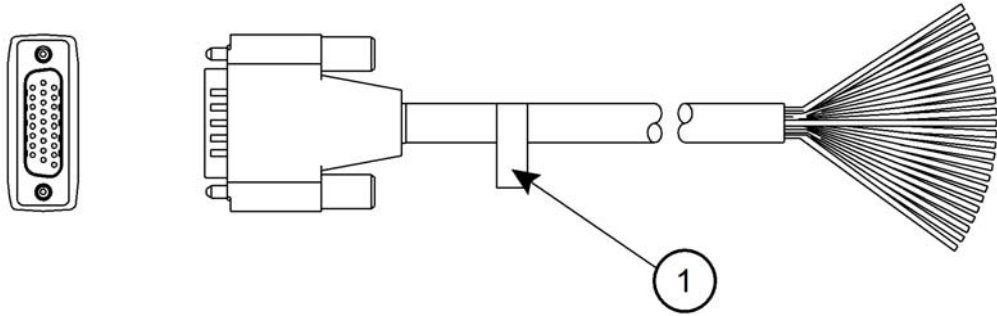

Wire Color Diagram  
 Two Colors = Insulator/Stripe  
 Three Colors = Insulator/Stripe/Dot

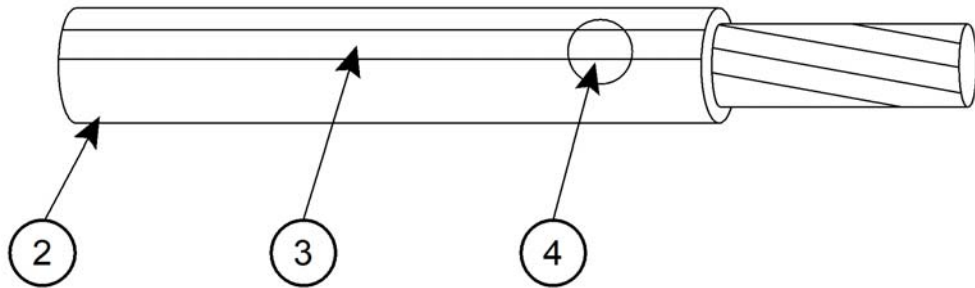

**Table 5.9** User I/O Cable Identification and Wire Color Diagram

Item	Description
1	Part number
2	Insulation
3	Stripe
4	Dot

## 5.3.7 User I/O Cable Pin Assignments

**Table 5.10** User I/O Cable Pin Assignments

Pin	Input/Output (All I/O are user definable)	Available Function	Signal Type	Signal Range	Color
1	Digital in 1*	See <a href="#">Table 5.11 Digital Input Functions</a>	Discrete Input	0 V to 24 V +/- 10%, 12 mA	Blk
2	Digital in 2*				Wht
3	Digital in 3*				Red
4	Digital in 4*				Grn
5	+24 V	N/A	24 V Source	24 V +/-10%, 250 mA Max	Orn
6					Blu
7	Digital out 1	See <a href="#">Table 5.12 Digital Output Functions</a>	Discrete Output	0 V to 24 V, -10%, 25mA Max	Wht/Blk
8	Digital out 2				Red/Blk
9	Digital out 3				Grn/Blk
10	Digital out 4				Orn/Blk
11	Digital in 5*	See <a href="#">Table 5.11 Digital Input Functions</a>	Discrete Input	0 V to 24 V +/- 10%, 12 mA	Blu/Blk
12	Digital in 6*				Blk/Wht
13	Digital in 7*				Red/Wht
14	GND	N/A	24 V Ground	0 V	Grn/Wht
15					Blu/Wht
16	Digital in 8*	See <a href="#">Table 5.11 Digital Input Functions</a>	Discrete Input	0 V to 24 V +/- 10%, 12 mA	Blk/Red
17	Analog in 1	See <a href="#">Table 5.13 Analog Input Functions</a>	Analog Input	0 V to +10 V, 2 mA	Wht/Red
18	Analog in 2				Orn/Red
19	Digital out 5	See <a href="#">Table 5.12 Digital Output Functions</a>	Discrete Output	0 V to 24 V +/- 10%, 12 mA Max	Blu/Red
20	Digital out 6				Red/Grn
21	Digital out 7				Orn/Grn
22	Digital out 8				Blk/Wht/Red

**Table 5.10** User I/O Cable Pin Assignments

Pin	Input/Output (All I/O are user definable)	Available Function	Signal Type	Signal Range	Color
23	Digital in 9*	See <a href="#">Table 5.11 Digital Input Functions</a>	Discrete Input	0 V to 24 V +/- 10%, 12 mA	Wht/Blk/Red
24	Analog out 1	See <a href="#">Table 5.14 Analog Output Functions</a>	Analog Output	0 V to 10 V +/- 5%, 1 mA Max	Red/Blk/Wht
25	Analog out 2				Grn/Blk/Wht
26	Analog GND	N/A	Analog Ground	0 V	Orn/Blk/Wht

\*Input signal should be kept at least 5ms.

## 5.3.8 Digital Input Functions

**Table 5.11** Digital Input Functions

Function	Description
ACT-Actuator Present	Must be active at power up to activate TRS, ULS, Interlock, Part in Place.
ACT-Cycle Abort	Will immediately terminate the current weld cycle and not accept another External Start until removed. Reset required is user settable.
ACT-Ground Detect	Will start scrub time. When scrub time expires, ultrasonics will be turned off.
ACT-Interlock In Place	Prevents a cycle from starting until the signal becomes active.
ACT-Part In Place	When enabled, signal must be active before weld cycle is started.
ACT-Trigger Switch (TRS)	Indicates the power supply to start ultrasonics.
ACT-Upperlimit Switch (ULS)	Tells the power supply that the actuator is at home position.
RF-Feedback A, B, C, D	Indicates which relay the RF switch has changed to. Bit 0 to bit 3 are binary coded values indicating the selected RF switch. It can also be uncoded. This function is user settable.
RF-Status Feedback	Indicates the RF switch has changed to the proper relay. <b>NOTICE</b> Single value. Not coded/uncoded like RF-Feedback A, B, C, D.
STD-Cable Detect	When enabled 24 volts must be present on pin at all times. If 24 volts is removed, suggesting that the cable has been removed, ultrasonics will not be allowed to run and will stop if already running.
STD-Display Lock	Locks the front panel display controls. Registers are read only when signal is active.
STD-External Amp Step Trigger	When set to +24 V sets amplitude to Amplitude 2. If set again to 0 V during a weld cycle will set amplitude back to Amplitude 1. Used only if amplitude stepping is turned on and set to external input.
STD-External Horn Scan	Starts horn scan. Signal must be maintained during the scan.
STD-External Reset	Resets alarm conditions.
STD-External Seek	Activates ultrasonic energy at 10% amplitude for the purpose of finding the ultrasonic stack resonant frequency.



**Table 5.11** Digital Input Functions

Function	Description
STD-External Sonics Delay	Delays the start of ultrasonics even if a trigger occurs. This can be used to enable an external operation to be complete before continuing the cycle (e. g. test device or part marking operation). If the delay is maintained for 1 minute, the cycle is aborted and all inputs must be cycled again.
STD-External Start	<p>Activates ultrasonic energy at the currently set amplitude.</p> <p><b>NOTICE</b> DCX F-EIP Power Supply must be in ready mode before External Start.</p> <p><b>WARNING</b> When using 0 V to activate ultrasonics (External Start signal), it is recommended to assign one input as Cable Detect to prevent sonics from activating if 24 V is lost by accident.</p>
STD-External Test	Performs a test cycle. Signal must be maintained.
STD-Load New Preset	Loads a weld preset as defined by Recall Preset Bits 1-32.
STD-Memory Clear	Centers the power supply start frequency.
STD-Recall Preset 1, 2, 4, 8, 16, 32	Bit 0 to bit 5 for preset recall binary code. This code will be used to recall a preset when Load Preset input is activated.
STD-Sonics Disable	Prevents ultrasonics from coming on. If active throughout a weld cycle, the cycle will be performed but without ultrasonics. Should the weld mode be time indeterminate (energy, power, etc) then the weld time will extend to the cutoff time.
STD-Start Cycle	Starts a cycle.

## 5.3.9 Digital Output Functions

**Table 5.12** Digital Output Functions

Function	Description
ACT-Actuator Home	Indicates that a ULS input has been received.
ACT-Afterburst Delay	Indicates if the weld cycle is in the Afterburst Delay state.
ACT-Afterburst Time	Indicates if the weld cycle is in the Afterburst state.
ACT-End of Hold Time	Indicates the system has reached the end of Hold since the cycle started.
ACT-Holdtime	Indicates if the weld cycle is in the Hold Time state.
RF-Select A-D	Output to select stacks 1 to 4 or a binary coded value (bit 0-3) to select RF relay.
STD-Amp1 Amp2	If output is 0 V, indicates the amplitude setting is Amplitude 1. If output is 24 V, indicates the amplitude setting is Amplitude 2.
STD-Confirm Preset Change	Output will go active when a preset has been recalled.
STD-Custom Alarm	Indicates a Custom Alarm has occurred. This function is user defined.
STD-Cycle Okay	Output will go inactive with cycle start input, and will go high at the end of the cycle if no alarms occurred.
STD-Cycle Start Out	Indicates start signal is active. It will stay active through weld time and hold time.
STD-General Alarm	Indicates an alarm occurred. This function is user configurable.
STD-Minus Energy Limit Alarm	Indicates the weld did not reach the minimum energy set.
STD-Minus Time Limit Alarm	Indicates the weld time has not reached the minimum time set.
STD-Minus Peakpower Limit Alarm	Indicates the weld has not reached the minimum peak power set.
STD-Overload Alarm	Indicates an overload alarm has occurred.
STD-Plus Energy Limit Alarm	Indicates the weld has exceeded the maximum energy set.

**Table 5.12** Digital Output Functions

Function	Description
STD-Plus Time Limit Alarm	Indicates the weld time did exceed the maximum time set.
STD-Plus Peakpower Limit Alarm	Indicates the weld has exceeded the maximum peak power set.
STD-Ready	If active, indicates the system is ready to start a weld cycle, enter test mode, or start a horn scan. If inactive, it indicates the system is already cycling, in test mode, performing a horn scan, or has a reset-required alarm.
STD-Seek/Scan Out	Indicates either a seek or a horn scan is in progress.
STD-Sonics Active	Indicates sonics are active.
STD-Start Signal Release	If output is active, it indicates the start signal can be removed. If output is inactive, it indicates start signal is either inactive or that it cannot yet be removed.
STD-Status	To be used to drive an external beeper. Single 0.5 second beeps will occur when trigger is received. Three Beeps indicate an alarm occurred (e.g. overload alarm). Beeps 0.5 seconds on, 0.5 seconds off long are in between each beep.
STD-Weldcycle Complete	Indicates if a weld cycle is no longer in process.

## 5.3.10 Analog Input Functions

**Table 5.13** Analog Input Functions

Function	Description		Valid Range
Amplitude In	Controls the amplitude of ultrasonic energy that will be delivered by the power supply.		1 V to 10 V* (10% to 100%)
Custom Input 1, 2	Define an analog voltage that can be used to create a cutoff. Voltage must be exceeded to produce the cutoff.		0 V to 10 V
Frequency Offset	Controls the frequency offset to the power supply operating frequency. Actual offset depends on the power supply operating frequency:		1 V to 9 V* (5 V is zero offset)
	<b>Frequency</b>	<b>Offset Range</b>	
	20 kHz	+/- 400 Hz	
	30 kHz	+/- 600 Hz	
	40 kHz	+/- 800 Hz	

\* If the input signals are not within their valid range, or if left unconnected, the power supply will use 50% amplitude and zero frequency offset, respectively.

### 5.3.11 Analog Output Functions

**Table 5.14** Analog Output Functions

Function	Description			Valid Range
Amplitude Out	Provides a 0 V to 10 V output signal proportional to amplitude (0% to 100%).			0 V to 10 V (0% to 100%)
Power Out	Provides a 0 V to 10 V output signal proportional to ultrasonic power output (0% to 100%).			0 V to 10 V (0% to 100%)
Frequency Out	Provides a 0 V to 10 V output signal that indicates memory plus offset. Actual frequency depends on the power supply operating frequency:			0 V to 10 V (5 V is zero offset)
	<b>Frequency</b>	<b>Lower Limit (0 V)</b>	<b>Upper Limit (10 V)</b>	
	20 kHz	19,450 Hz	20,450 Hz	
	30 kHz	29,250 Hz	30,750 Hz	
	40 kHz	38,900 Hz	40,900 Hz	

## 5.3.12 Default Branson User I/O Connector PIN Assignments

### Software V6.0 - V6.4

**Table 5.15** Default Branson User I/O Connector PIN Assignments, V6.0

Pin	Function	I/O Type	Values
1	STD-External Start	Input Digital	Apply +24 VDC to run cycle <b>NOTICE</b> DCX F-EIP Power Supply must be in ready mode before External Start.
2	STD-External Seek	Input Digital	Apply +24 VDC to perform a seek
3	STD-External Reset	Input Digital	Apply +24 VDC to reset alarm
4	STD-Memory Clear	Input Digital	Apply +24 VDC to clear memory
5	+24 VDC Source	I/O Signal Source	+24 V, 250 mA max. (sourced from the customer supplied 24 V external power supply).
6			
7	STD-Ready	Output Digital	+24 V indicates the system is ready
8	STD-Sonics Active	Output Digital	+24 V indicates ultrasonics are active
9	STD-General Alarm	Output Digital	+24 V indicates an alarm occurred
10	STD-Seek/Scan Out	Output Digital	+24 V indicates either Seek or a Scan is in progress
11	STD-Recall Preset 1	Input Digital	Bit 0 for preset recall binary code
12	STD-Recall Preset 2	Input Digital	Bit 1 for preset recall binary code
13	STD-Recall Preset 4	Input Digital	Bit 2 for preset recall binary code
14	+24 VDC Return and I/O Return	I/O Signal Return	Return for all pins except pins 17, 18, 24, and 25
15			
16	STD-Recall Preset 8	Input Digital	Bit 3 for preset recall binary code
17	Amplitude In	Input Analog	1 V to + 10 V (10% to 100%)*
18	Frequency Offset	Input Analog	1 V to + 9 V (5 V is zero offset)
19	STD-Amp1 Amp2	Output Digital	Indicates amplitude setting 0 V for Amplitude 1, +24 V for Amplitude 2
20	STD-Overload Alarm	Output Digital	+24 V indicates an overload alarm occurred.
21	STD-Start Signal Release	Output Digital	+24 V indicates start signal can be removed.

**Table 5.15** Default Branson User I/O Connector PIN Assignments, V6.0

Pin	Function	I/O Type	Values
22	STD-Confirm Preset Change	Output Digital	+24 V indicates a load new preset request has occurred and the preset was successfully recalled.
23	ACT-Trigger Switch	Input Digital	+24 V must be present for ultrasonics to be enabled.
24	Power Out	Output Analog	0 V to + 10 V (0% to 100%)
25	Amplitude Out	Output Analog	0 V to + 10 V (0% to 100%)
26	Analog Signal Return	Analog Signal Return	Return for pins 17, 18, 24, and 25

\* If the input signals are not within their valid range, or if left unconnected, the power supply will use 50% amplitude and zero frequency offset, respectively.

## Software V6.5 or Newer

**Table 5.16** Default Branson User I/O Connector PIN Assignments, V6.5

Pin	Function	I/O Type	Values
1	STD-External Start	Input Digital	Apply +24 VDC to run cycle <b>NOTICE</b> DCX F-EIP Power Supply must be in ready mode before External Start.
2	STD-External Seek	Input Digital	Apply +24 VDC to perform a seek
3	STD-External Reset	Input Digital	Apply +24 VDC to reset alarm
4	STD-Memory Clear	Input Digital	Apply +24 VDC to clear memory
5	+24 VDC Source	I/O Signal Source	+24 V, 250 mA max. (sourced from the customer supplied 24 V external power supply).
6			
7	STD-Ready	Output Digital	+24 V indicates the system is ready
8	STD-Sonics Active	Output Digital	+24 V indicates ultrasonics are active
9	STD-General Alarm	Output Digital	+24 V indicates an alarm occurred
10	STD-Seek/Scan Out	Output Digital	+24 V indicates either Seek or a Scan is in progress
11	STD-Recall Preset 1	Input Digital	Bit 0 for preset recall binary code
12	STD-Recall Preset 2	Input Digital	Bit 1 for preset recall binary code
13	ACT-Ground Detect	Input Digital	Bit 2 for preset recall binary code
14	+24 VDC Return and I/O Return	I/O Signal Return	Return for all pins except pins 17, 18, 24, and 25
15			
16	ACT-Cycle Abort	Input Digital	Bit 3 for preset recall binary code
17	Amplitude In	Input Analog	1 V to + 10 V (10% to 100%)*
18	Frequency Offset	Input Analog	1 V to + 9 V (5 V is zero offset)
19	STD-Confirm Preset Change	Output Digital	Indicates amplitude setting 0 V for Amplitude 1, +24 V for Amplitude 2
20	STD-Overload Alarm	Output Digital	+24 V indicates an overload alarm occurred.
21	STD-Plus Peak Power Limit Alarm	Output Digital	+24 V indicates start signal can be removed.
22	STD-Minus Peak Power Limit Alarm	Output Digital	+24 V indicates a load new preset request has occurred and the preset was successfully recalled.
23	STD-Display Lock	Input Digital	+24 V must be present for ultrasonics to be enabled.



**Table 5.16** Default Branson User I/O Connector PIN Assignments, V6.5

Pin	Function	I/O Type	Values
24	Power Out	Output Analog	0 V to + 10 V (0% to 100%)
25	Amplitude Out	Output Analog	0 V to + 10 V (0% to 100%)
26	Analog Signal Return	Analog Signal Return	Return for pins 17, 18, 24, and 25

\* If the input signals are not within their valid range, or if left unconnected, the power supply will use 50% amplitude and zero frequency offset, respectively.

## 5.3.13 Typical Digital I/O Wiring Examples

Figure 5.9 Typical Digital I/O Wiring Examples

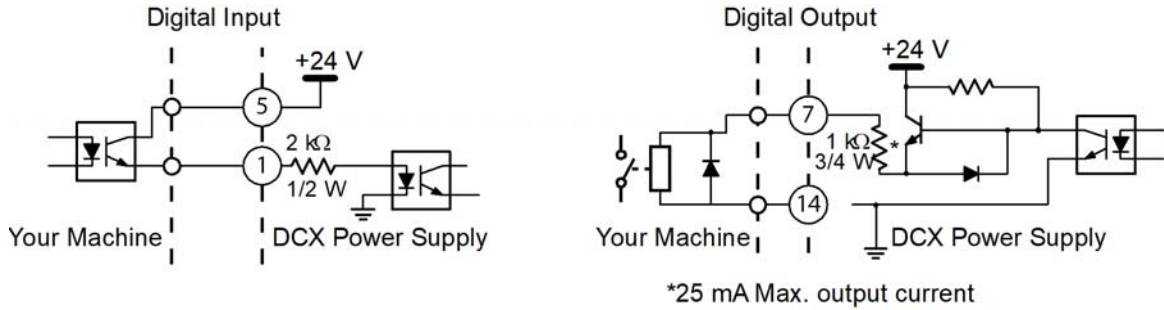

## 5.3.14 Typical Analog I/O Wiring Examples

Figure 5.10 Typical Analog I/O Wiring Examples

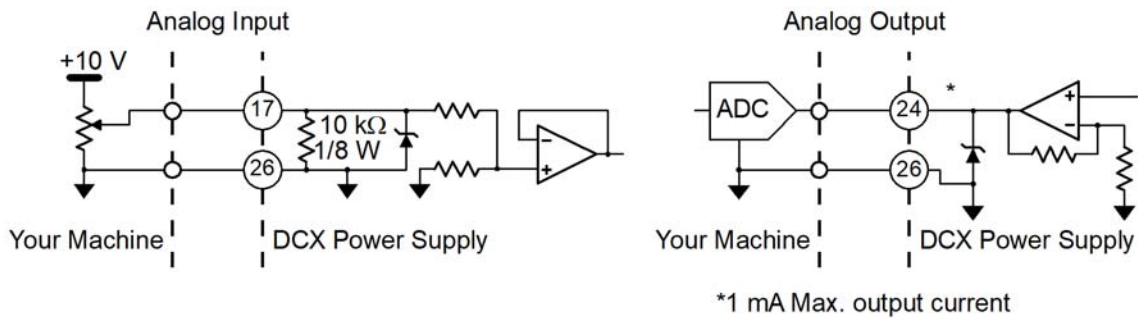



## 5.3.15 Output Power (RF Cable) Connection

Ultrasonic energy is delivered to the SHV connector on the power supply, which is then transmitted to the converter via the RF cable. The RF connector position depends on the power supply configuration. For Horizontal models it is located on the rear panel of the power supply. For Vertical models it is located on the bottom panel of the power supply.

To reduce electromagnetic interference (EMI), RF cables are equipped with a ferrite core (plastic case) on one end. This end is meant to be connected to the power supply.

WARNING	High Voltage Hazard
	Operating the System with the RF Cable disconnected or damaged can present an electrical shock hazard.

WARNING	High Voltage Hazard
	To avoid the possibility of electrical shock. Converters need to be properly grounded.

NOTICE	
	To avoid the possibility of EMI interference, ensure the RF connection to the power supply is made with the cable end that has the ferrite core box attached (see <a href="#">Figure 5.11 RF Cable Connection</a> ).

**Figure 5.11** RF Cable Connection

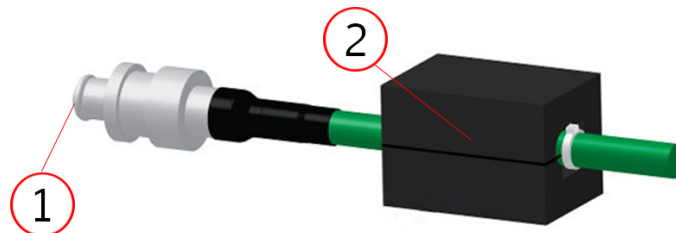



**Table 5.17** RF Cable Connection

Item	Description
1	To Power Supply
2	Ferrite Core Box

## 5.3.16 Input Power Connection

WARNING	High Voltage Hazard
	<p>Ensure all electrical power is off when wiring input power to your DCX F-EIP Power Supply connector block.</p> <p>To prevent the possibility of an electrical shock, ground the power supply by securing an 8 gauge grounded conductor to the ground screw located next to the air outlet.</p>

WARNING	High Voltage Hazard
	<p>If miss-wired, the power supply can present an electrical shock hazard.</p>

NOTICE	
	<p>The power supply can be permanently damaged if it is connected to the incorrect line voltage, or if the connection is mis-wired.</p>

Use the following procedure to connect the power supply to a 24 VDC 2.5A external power supply and to a single-phase, grounded 3-wire, 50 Hz or 60 Hz 200 V to 230 V power source. The 24 VDC power supply must be safety certified and agency approved.

**Table 5.18** Input Power Connection

Step	Action
1	Detach the connector block on the back of the power supply.
2	Use two properly sized wires (according to local standards) to connect a 24 VDC 2.5A power supply as shown on <a href="#">Figure 5.6 DCX F-EIP Power Supply Connections (Horizontal Model)</a> .
3	Use three properly sized wires (No. 12 gauge, 2.5 mm or according to local standards) to connect the line 1, line 2, and ground to the connector block as shown on <a href="#">Figure 5.6 DCX F-EIP Power Supply Connections (Horizontal Model)</a> . Choose wires according to the current rating as specified in <a href="#">Table 5.6 Input Current and Circuit Breaker Specifications</a> and on the label located on the back of the unit. Be sure to use agency approved wiring and use sleeving or tubing on each wire for double insulation.
4	Secure an 8 gauge grounded conductor to the ground screw located next to the air outlet.

**Table 5.18** Input Power Connection

Step	Action
5	Connect the converter-booster-horn stack to the power supply using the RF cable. See <a href="#">5.3.15 Output Power (RF Cable) Connection</a> .
6	Ensure the power switch on the back of the unit is in the OFF position. Plug the connector block back into the power supply. Tighten the two securing screws.
7	Connect the power supply to a single-phase, grounded, 3-wire, 50 Hz or 60 Hz 200 V to 230 V power source.



## 5.4 Power Supply Setup

Certain power supply configurations can be modified from the factory setting if needed. Although not usually requiring modifications from the factory setting, the following features are selectable:

- **Afterburst:** Allows for a short activation of ultrasonics at the end of the weld cycle to reliably release parts from the horn
- **Cutoffs:** Allows for setting parameter values for immediately terminating a weld cycle: Time (S); Energy (J); Peak Power (%); Frequency Low (Hz); Frequency High (Hz); Custom Input1 (V); and Custom Input2 (v)
- **End of Weld Store:** Provides an option for selecting if the stack frequency is stored at the end of each weld cycle
- **Energy Brake:** Allows the user to set the power supply to reduce the amplitude before the sonics are shut off
- **Frequency Offset:** Allows for varying the start frequency by way of external controls (analog signal applied through the user I/O analog input) or setting a fixed value using the web page interface. This is useful for certain applications, where the force applied on the fixture or anvil causes a frequency shift in the stack's operation
- **Limits:** Allows for setting up limits within a weld mode: +/- Continuous; +/- Time (s); +/- Energy (J); or +/- Peak Power (%)
- **Mode:** Allows for selecting the weld mode from the different available options: Continuous; Time (s); Energy (J); Peak Power (%); and Ground detect
- **Power Up:** Allows an option to configure the power supply to perform a seek on power up; a horn scan on power up; or to perform no action at power up
- **Seek Ramp:** Provides a selection for different power supply seek ramp times
- **Seek Time:** Provides an option for selecting seek duration
- **Start Ramp:** Provides a selection for different start ramp times. This controls how fast the amplitude of the horn rises from 0 to 100. Long ramp times may be useful when using large horns or high gain stacks
- **Timed Seek:** Provides an option for monitoring, and storing the operating frequency at timed intervals (60 seconds). Periodic frequency seeks may be helpful when welder is not used for long periods of time. Seeks are timed from the moment sonics was last activated
- **Weld Amplitude:** Allows for varying the amplitude (10% to 100%) using the front panel LCD, the web page interface, or by way of external controls (analog signal applied through the user I/O analog input). Via the web page interface scrub amplitude, afterburst amplitude, and amplitude stepping options may also be configured

For instruction on how to change the power supply settings refer to [7.4 Configuring the Power Supply Registers](#) in [Chapter 7: Operation](#).

## 5.5 Assembling the Acoustic Stack

CAUTION	General Warning
	<p>The following procedure must be performed by a setup person. If necessary, secure the largest portion of a square or rectangular horn in a soft jawed vise. NEVER attempt to assemble or remove a horn by holding the converter housing or the booster clamp ring in a vise.</p>
CAUTION	General Warning
	<p>Do not use silicone grease with Mylar plastic film washers. Use only 1 (one) Mylar plastic film washer of the correct inside and outside diameters at each interface.</p>
NOTICE	
	<p>The use of a Branson torque wrench or the equivalent is recommended. P/N 101-063-787 for 20 kHz, and 30 kHz systems and 101-063-618 for 40 kHz systems.</p>

**Figure 5.12** Assembling the Acoustic Stack

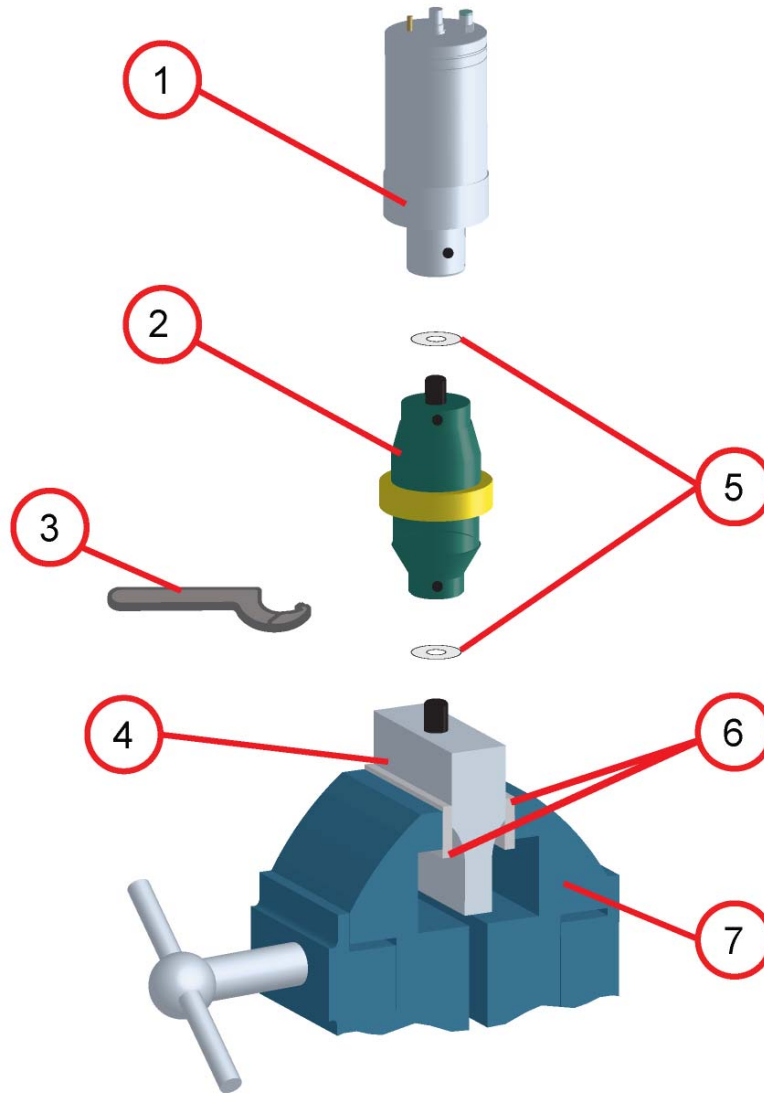

## Acoustic Stack Description

**Table 5.19** Acoustic Stack Description

Item	Description
1	Converter
2	Booster
3	Spanner (provided)
4	Horn
5	See stack assembly procedure
6	Vise Jaw protectors (aluminum or soft metal)
7	Vise



## Stack Torque Values

**Table 5.20** Stack Torque Values

Frequency	Torque
20 kHz	220 in·lb (24.85 N·m)
30 kHz	185 in·lb (21 N·m)
40 kHz	95 in·lb (10.73 N·m)

## Tools

**Table 5.21** Tools

Tool	EDP Number
20 kHz, and 30 kHz Torque Wrench Kit	101-063-787
40 kHz Torque Wrench	101-063-618
20 kHz Spanner Wrench	101-118-039
30 kHz Spanner Wrench	201-118-033
40 kHz Spanner Wrench	201-118-024
Silicone Grease	101-053-002
Mylar Plastic Film Washers (20 kHz)	100-063-357
Mylar Plastic Film Washers (30 kHz)	100-063-632

## 5.5.1 For a 20 kHz System

**Table 5.22** 20 kHz System

Step	Action
1	Ensure that the mating surfaces of the converter, booster, and horn are clean, and that the threaded holes are free of foreign material.
2	Install a single Mylar plastic film washer (matching the size of the washer to the stud) to each interface.
3	Assemble the converter to the booster and the booster to the horn.
4	Torque to 220 in·lb (24.85 N·m) at each interface.

## 5.5.2 For a 30 kHz System

**Table 5.23** 30 kHz System

Step	Action
1	Ensure that the mating surfaces of the converter, booster, and horn are clean, and that the threaded holes are free of foreign material.
2	Install a single Mylar plastic film washer (matching the size of the washer to the stud) to each interface.
3	Assemble the converter to the booster and the booster to the horn.
4	Torque to 185 in·lb (21 N·m) at each interface.

## 5.5.3 For a 40 kHz System

**Table 5.24** 40 kHz System

Step	Action
1	Ensure that the mating surfaces of the converter, booster, and horn are clean, and that the threaded holes are free of foreign material.
2	Coat each interface surface with a thin film of silicon grease - but do not apply silicon grease to a threaded stud or tip.
3	Assemble the converter to the booster and the booster to the horn.
4	Torque to 95 in·lb (10.73 N·m) at each interface.

### 5.5.4 Connecting Tip to Horn

1. Ensure that the mating surfaces of the tip and horn are clean. Remove any foreign matter from the threaded stud and hole.
2. Hand assemble the tip to the horn. Assemble dry. Do not use any silicone grease.
3. Use the spanner wrench and an open-end wrench (refer to [Figure 5.13 Connecting Tip to Horn](#)) and tighten to the following torque tip specifications:

**Figure 5.13** Connecting Tip to Horn

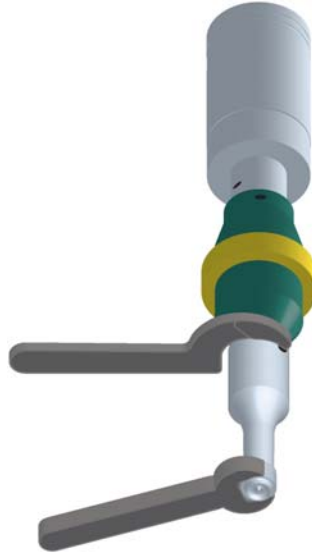

**Table 5.25** Tip to horn torque values

Tip Thread	Torque
1/4 - 28	110 in·lbs (12.42 N·m)
3/8 - 24	180 in·lbs (20.33 N·m)

## 5.6 Converter Cooling

Converter performance and reliability can be adversely affected if the converter ceramics are subjected to temperatures above 140° F (60° C). The converter front driver temperature should not exceed 122° F (50° C).

To prolong converter life and maintain a high degree of system reliability, the converter should be cooled with clean, dry, compressed air, particularly if your application calls for continuous ultrasonic operation. Converter cooling is especially critical in 40 kHz applications.

Use one of the following procedures to determine if a converter is operating close to the maximum allowable temperature. Check converter temperature immediately after substantial machine operation and without power applied to the horn.

- Press a pyrometer probe (or similar temperature measuring device) against the front driver of the converter assembly. Wait for the probe to reach the temperature of the shell. If the temperature is 120° F (49° C) or higher, the converter requires a cooling air stream
- If a temperature measuring device is unavailable, use your hand to feel the shell of the converter. If the converter is hot to touch, the converter requires a cooling air stream

High duty cycles require additional cooling for the converter. System average power must be limited to the specified continuous maximum. Higher peak power, up to the maximum acceptable power limit, with an on time of up to 10 seconds may be obtained, if appropriate off time ensures that, on average, the continuous duty maximum power is not exceeded.

**Table 5.26** Continuous Duty Max. Power & Full Power Duty Cycle

Configuration	Continuous Duty Max. Power	Full Power Duty Cycle
20 kHz / 1250 W	800 W	10 s on 10 s off (50% Duty Cycle)
20 kHz / 2500 W	1600 W	10 s on 10 s off (50% Duty Cycle)
20 kHz / 4000 W	2000 W	5 s on 15 s off (25% Duty Cycle)
30 kHz / 750 W	300 W	2 s on 2 s off (50% Duty Cycle)
30 kHz / 1500 W	800 W	2 s on 2 s off (50% Duty Cycle)
40 kHz / 400 W	300 W	10 s on 10 s off (50% Duty Cycle)
40 kHz / 800 W	400 W	10 s on 10 s off (50% Duty Cycle)

If converter cooling is required, use the following steps:

**Table 5.27** Converter Cooling Procedure

Step	Action
1	Start with a 50 psi (345 kPa) air source or higher from a 0.06 in (1.5 mm) I.D. orifice
2	Perform a run of welding operations.
3	Immediately after completing the welding run, check the converter temperature.
4	If the converter is still too hot, increase the diameter of the orifice in small increments until the temperature falls within the ranges in the chart.

A 0.06 in (1.5 mm) orifice at 50 psi (345 kPa) will result in a reading of 80 ft<sup>3</sup> (2.26 m<sup>3</sup>) per hour. This should be sufficient to cool most operations requiring a cooling air stream. In continuous welding operations, or applications with longer duty cycles, it may be necessary to cool the horn as well as the converter. Horns may require cooling because of the heat transfer from contacting the work piece.

## 5.7 Testing the Installation

To test the power supply follow the procedure described in [7.6 Ultrasonics Test Procedure](#) in [Chapter 7: Operation](#).

## 5.8 Still Need Help?

Branson is pleased that you chose our product and we are here for you! If you need parts or technical assistance with your DCX F-EIP Power Supply system, call your local Branson representative. Please refer to [1.4 How to Contact Branson](#) for a list of Branson key contacts.





---

# Chapter 6: Converters and Boosters

---

6.1 Converters and Boosters ..... 86

## 6.1 Converters and Boosters

A variety of converters and boosters available for use with the DCX F-EIP Power Supply are illustrated in the following pages.

WARNING	High Voltage Hazard
	To avoid the possibility of electrical shock. Converters need to be properly grounded.

NOTICE	
	Special adaptor cables are available to connect to MS-style converters (CR20 and 4TR). See <a href="#">Table 9.8 DCX F-EIP Power Supply System Cables</a> .

**Figure 6.1** 20 kHz typical Converter Dimensions

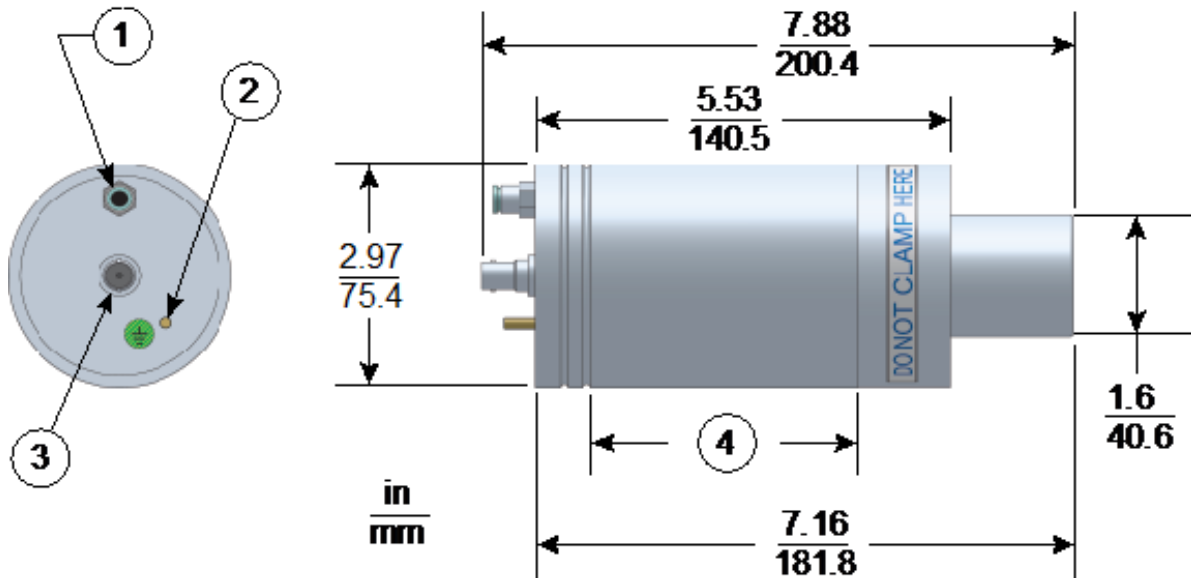

**Table 6.1** 20 kHz Converter

Item	Description
1	Air inlet
2	Ground stud
3	SHV connector
4	Grip area

**Figure 6.2** 20 kHz Booster Dimensions

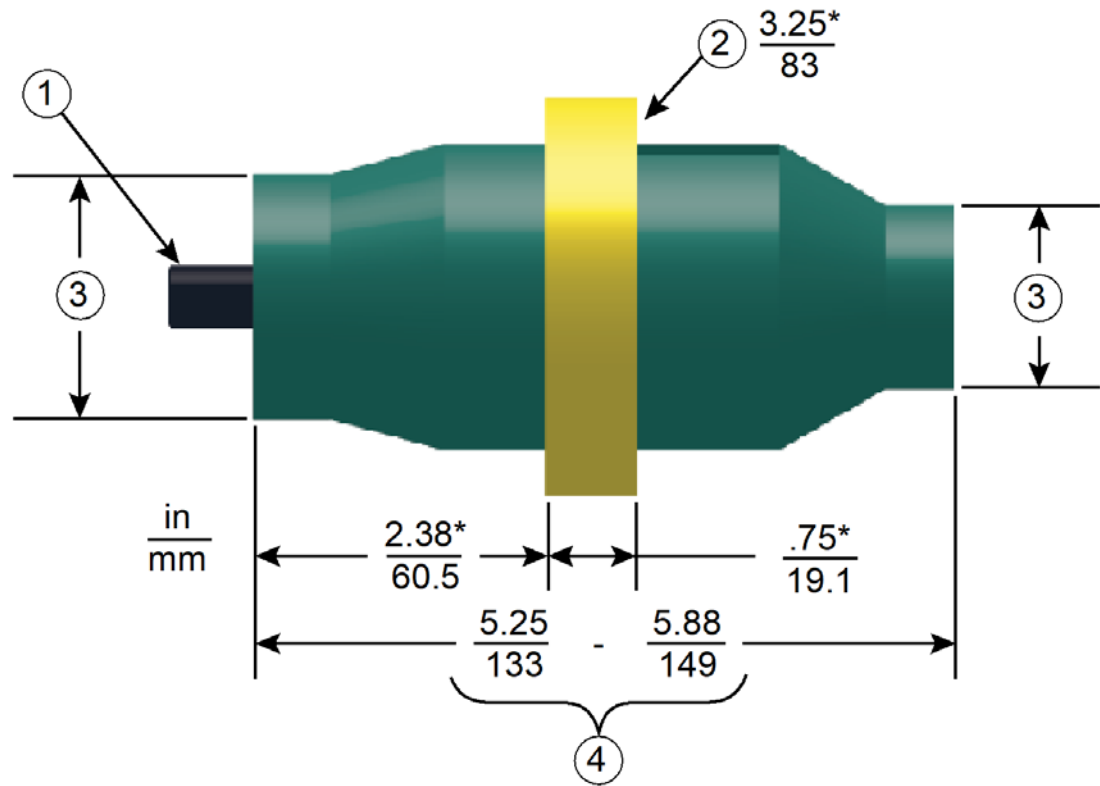
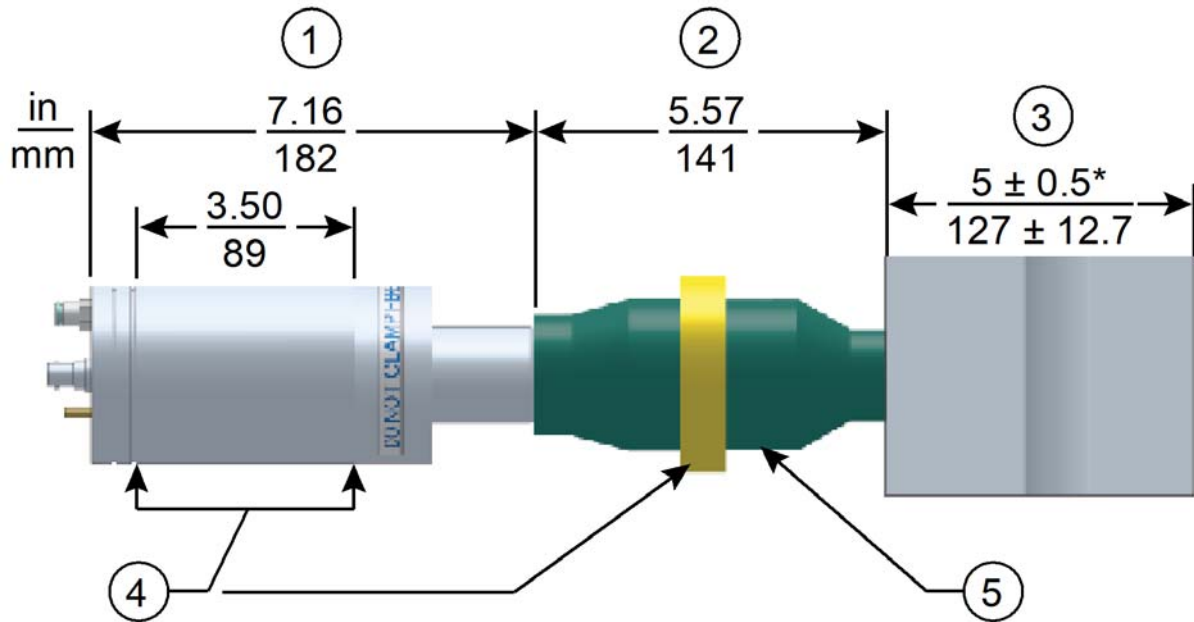

**Table 6.2** 20 kHz Booster

Item	Description
1	1/2 - 20 x 1 - 1/4 stud (Ti boosters) 1/2 - 20 x 1 - 1/2 stud (Al boosters)
2	Grip Ring Diameter
3	Variable
4	Varies with tuning and gain

\* These dimensions do not vary.

**Figure 6.3** 20 kHz Converter/Booster/Horn, Typical Dimensions

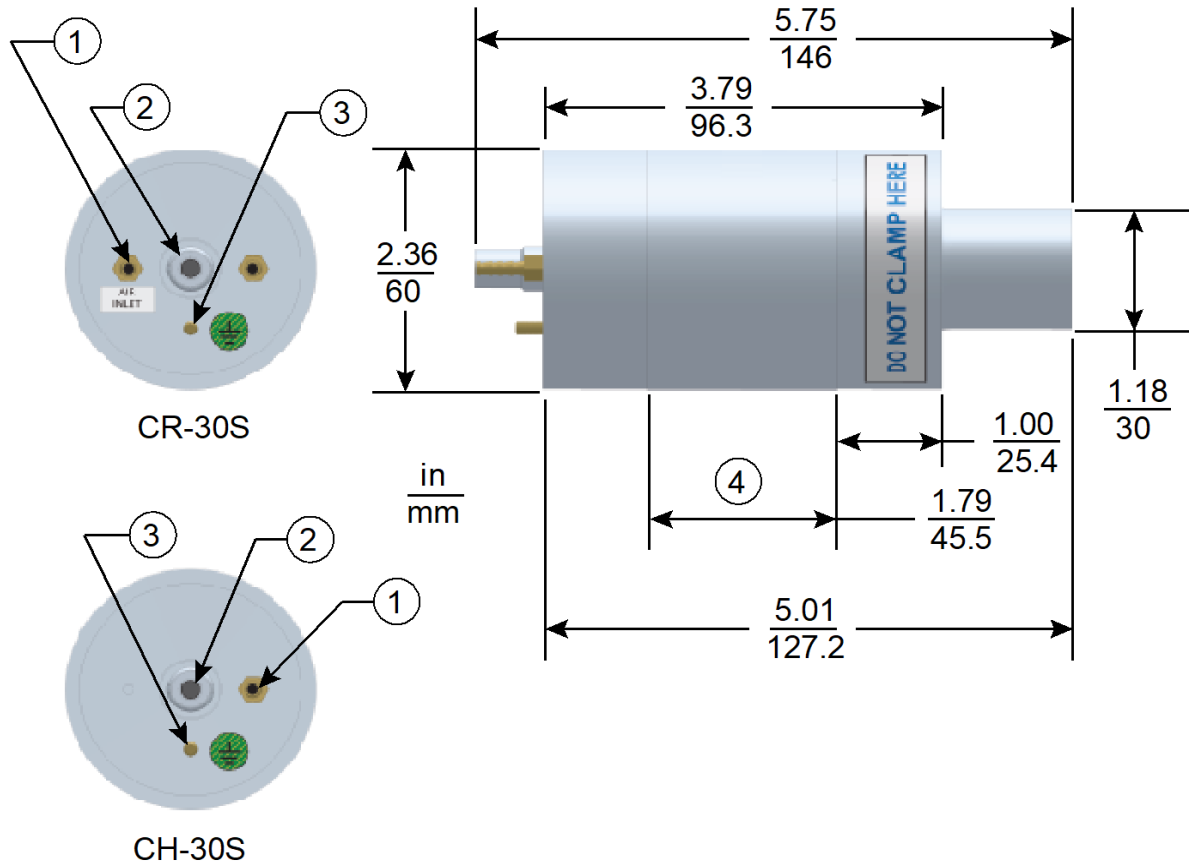

**Table 6.3** 20 kHz Converter/Booster/Horn

Item	Description
1	Converter
2	Booster
3	One-half wavelength horn
4	Recommended clamping area
5	Booster front end diameter will vary with amplitude

\* Overall horn length can vary beyond these typical dimensions depending on the application.

**Figure 6.4** 30 kHz Converter Dimensions



**Table 6.4** 30 kHz Converter

Item	Description
1	Air inlet
2	SHV connector
3	Ground stud
4	Grip area

CR-30S and CH-30S are dimensionally identical, and differ only in their respective cooling feature.

CR-30S has flow through cooling, and CH-30S has closed loop cooling (air circulates in the converter and returns to its source).

**Figure 6.5** 30 kHz Booster Dimensions

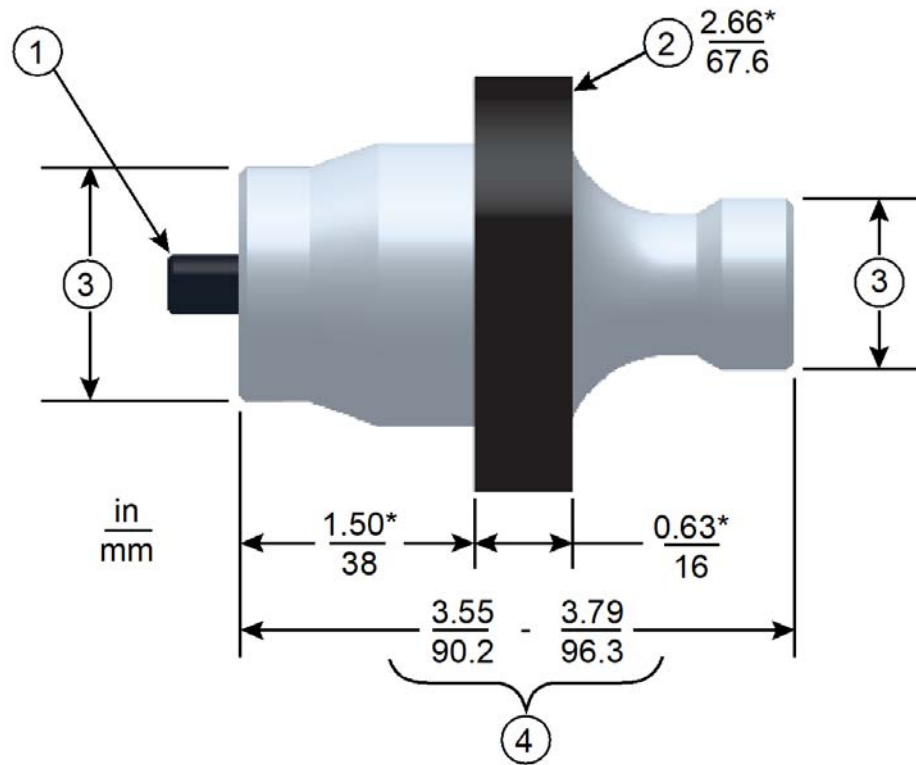
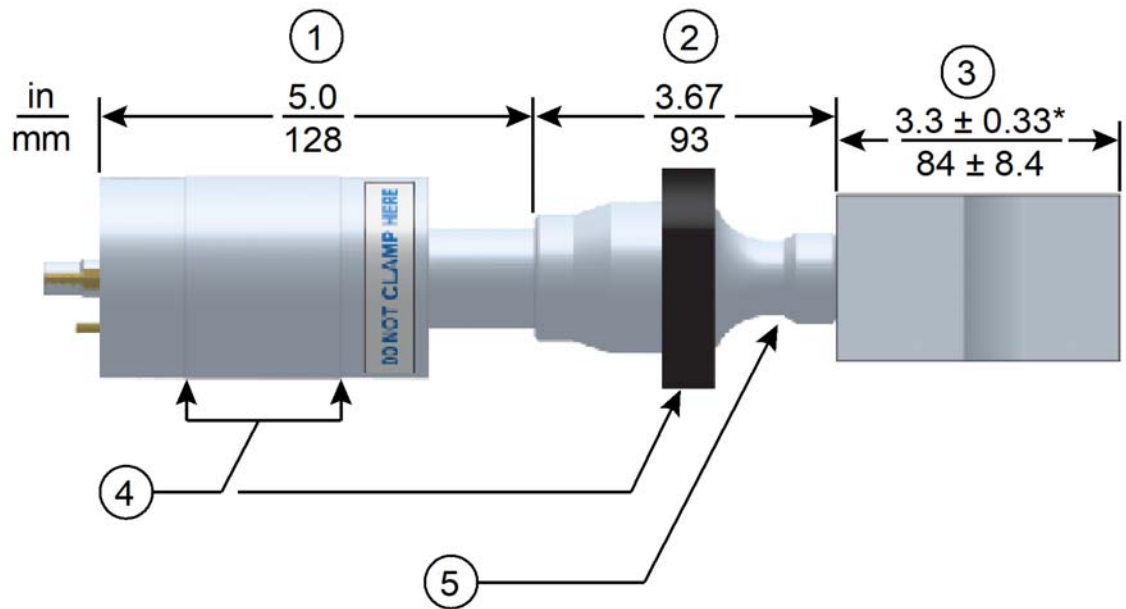

**Table 6.5** 30 kHz Booster

Item	Description
1	3/8 - 24 x 1 - 1/4 stud
2	Grip Ring Diameter
3	Variable
4	Varies with tuning and gain

\* These dimensions do not vary.

**Figure 6.6** 30 kHz Converter/Booster/Horn, Typical Dimensions

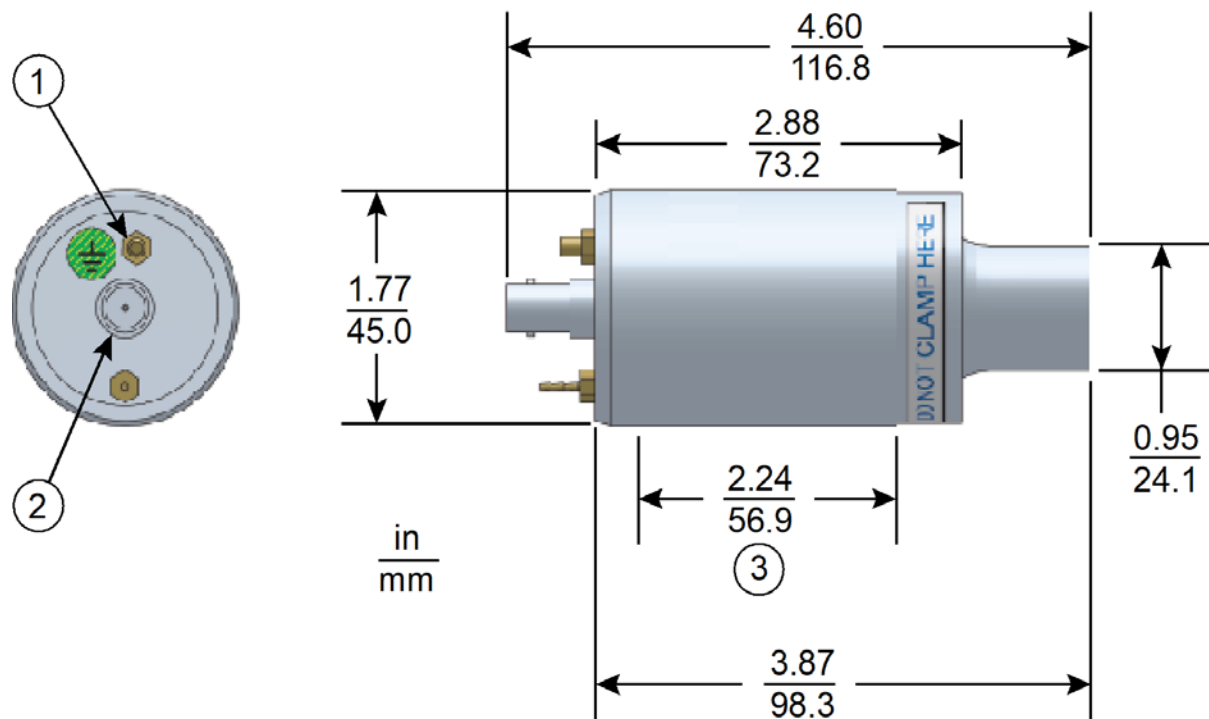

**Table 6.6** 30 kHz Converter/Booster/Horn

Item	Description
1	Converter
2	Booster
3	One-half wavelength horn
4	Recommended clamping area
5	Booster front end diameter will vary with amplitude

\* Overall horn length can vary beyond these typical dimensions depending on the application.

**Figure 6.7** 40 kHz, 4TR Converter Dimensions

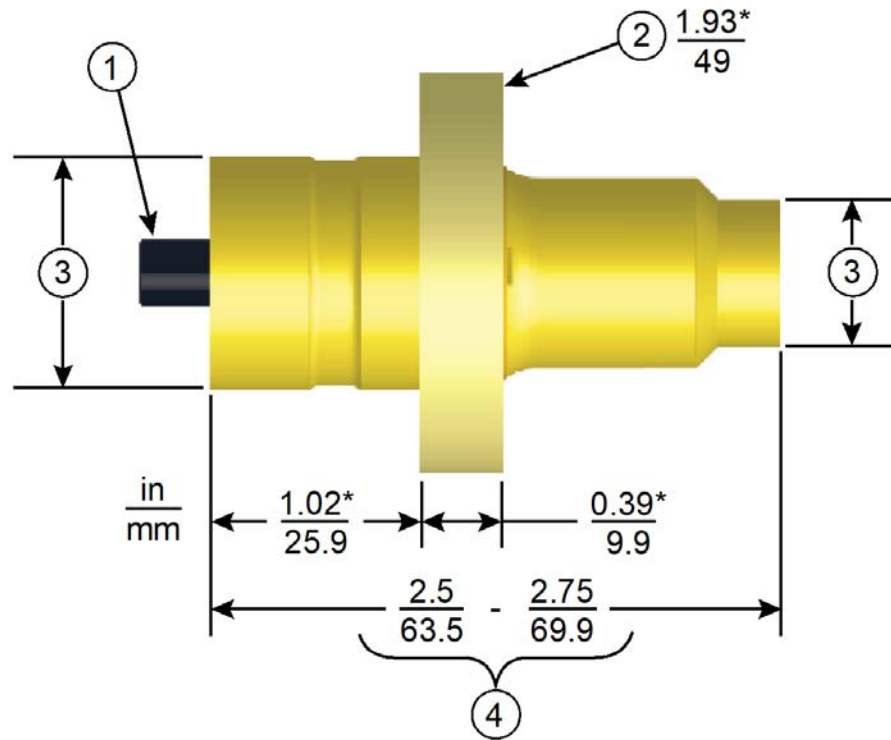

**Table 6.7** 40 kHz, 4TR Converter

Item	Description
1	Ground stud
2	SHV connector
3	Grip area



**Figure 6.8** 40 kHz Booster Dimensions



**Table 6.8** 40 kHz Booster

Item	Description
1	M8 x 1 - 1/4 stud (Ti boosters) M8 x 1 - 1/2 stud (Al boosters)
2	Grip ring diameter
3	Variable
4	Varies with tuning and gain

**Figure 6.9** 40 kHz Converter/Booster/Horn, Typical Dimensions

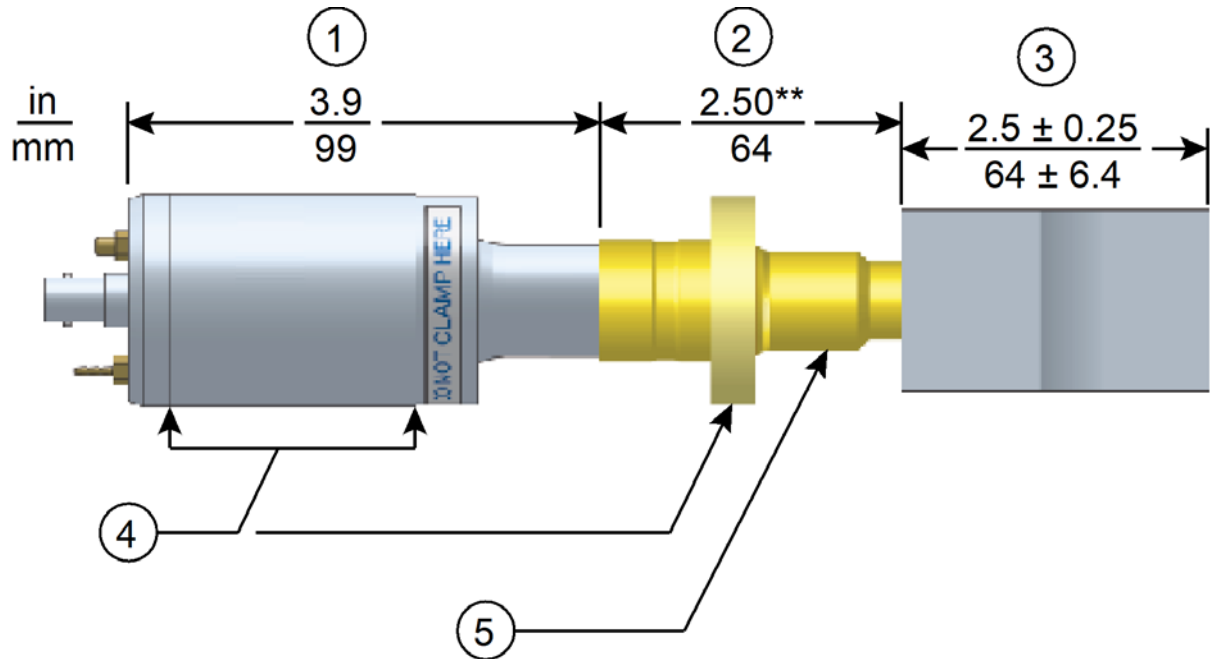

**Table 6.9** 40 kHz Converter/Booster/Horn

Item	Description
1	Converter
2	Booster
3	One-half wavelength horn
4	Recommended clamping area
5	Booster front end diameter will vary with amplitude

\* Overall horn length can vary beyond these typical dimensions depending on the application.

\*\* Dimension varies with tuning and gain.

## 6.1.1 Component Functional Description

### Ultrasonic Stack

#### Converter

The converter is mounted in the customer's automation as part of the ultrasonic stack. The ultrasonic electrical energy from the power supply is applied to the converter (sometimes called the transducer). This transforms the high frequency electrical oscillations into mechanical vibrations at the same frequency as the electrical oscillations. The heart of the converter are piezoelectric ceramic elements. When subjected to an alternating voltage, these elements alternately expand and contract, resulting in better than 90% conversion of electrical to mechanical energy.

#### Booster

It is important to be able to modify the horn face amplitude for successful ultrasonic assembly. The booster provides a means to modify the amplitude. It is designed to couple different ratios of ultrasonic energy to the horn, which will in turn increase or decrease the amplitude at the face of the horn. This is accomplished by varying the ratios of the masses of the input and output half sections of the booster.

The booster is a resonant half-wave section of aluminum or titanium. It is mounted between the converter and the horn, as part of the ultrasonic stack. It also provides a clamping point for rigid stack mounting.

#### Horn

The horn is selected or designed for a specific application. Each horn is tuned typically as a half-wave section that applies the necessary force and vibration uniformly to the parts to be assembled. It transfers ultrasonic vibrations from the converter to the workpiece. The horn is mounted to the booster as part of the ultrasonic stack.

Depending on their profile, horns are referred to as stepped, conical, exponential, bar, or catenoidal. The shape of the horn determines the amplitude at the face of the horn. Depending on the application, horns can be made from titanium alloys, aluminum, or steel. Titanium alloys are the best materials for horn fabrication due to their high level of strength and low loss. Aluminum horns are usually chrome- or nickel-plated or hard-coated to reduce wear. Steel horns are for low amplitude requiring hardness, such as ultrasonic insertion applications.

## Solid Mount Boosters

The solid mount booster is a one-half wave-length resonant section made exclusively of titanium. It is mounted between the converter and the horn, modifying the amplitude of vibration applied to the horn and providing a clamping point.

The solid mount booster is superior to prior versions in that deflection is minimized. This is the result of a redesigned clamp-ring which employs a metal-to-metal press fit rather than an O-ring assembly.

The advantage this booster offers is its improved rigidity. For continuous applications, this means more energy delivered to the product, while in plunge applications, improved alignment is possible. The solid mount provides improved positional alignment and will benefit continuous applications where high force, high side load, or high cycle rates are necessary. In plunge welding applications, overall deflection is reduced by an average of 0.0025 in. (0.064 mm) over a wide variety of materials, joint designs, and operating conditions. The results of this testing in combination with information drawn from field testing indicate that the solid mount will benefit plunge applications where precision alignment is necessary (such as staking, swaging, or insertion) or where concentricity/parallelism is critical.

---

## Chapter 7: Operation

---

7.1	Setting Primary Parameters . . . . .	98
7.2	Setting the Amplitude. . . . .	109
7.3	Resetting the Power Supply Alarms. . . . .	111
7.4	Configuring the Power Supply Registers . . . . .	112
7.5	LCD Bar-Graph . . . . .	117
7.6	Ultrasonics Test Procedure. . . . .	120
7.7	Using the I/O Connections. . . . .	122

## 7.1 Setting Primary Parameters

After analyzing your specific application, you can determine the Weld Mode to use to weld your parts. A Weld Mode is a set of parameters that governs the weld. Contact the Branson Ultrasonics Applications Laboratory for more information on determining the best mode for welding your application. See [1.4 How to Contact Branson](#).

There are five Weld Modes to choose from Continuous, Time, Energy, Peak Power, and Ground Detect Modes. The following table describes each mode:

**Table 7.1** Summary of Weld Modes



Weld Mode	Description
Continuous	On this mode, ultrasonic energy will be delivered continuously while the start signal is present.
Time	You select the length of time (in seconds) that ultrasonic energy will be transmitted to your parts.
Energy	You select the amount of energy (in Joules) that will be transmitted to your parts. (A Joule is one Watt-Second.)
Peak Power	You select the peak power level (as a percentage of full power) at which the weld is terminated.
Ground Detect	<p>The DCX F-EIP Power Supply provides ultrasonic energy until the horn comes in contact with your electrically isolated fixture or with the anvil, providing that you made an electrical connection between the actuator and your fixture or anvil.</p> <p><b>NOTICE</b></p> <p>Ground detect signal is required to terminate the weld and enter scrub time.</p> <p>It is necessary to install Ground Detect Kit (EDP No. 125-063-061) in order to utilize this feature.</p>

NOTICE	
	In these modes, cutoffs can be used as secondary controls.

## 7.1.1 Continuous Mode

In this mode, ultrasonic energy will be delivered continuously while the start signal is present. Within Continuous Mode, you can also select several other parameters, ranging from afterburst to limits and cutoffs. For more information on setting the optional parameters within Continuous Mode, or any other welding mode, refer to the DCX A/F Series Web Page Instruction Manual.

**Table 7.2** Continuous Mode Operational Sequence

Step	Action	Reference
1	<p>Press the Configuration key until the number icon (#) appears on the LCD.</p> <p>The power supply will display register 101 at every power up.</p>	 <p>The image shows a close-up of the control panel. The LCD screen displays '101' in large digits. To the right of the digits is a '#' icon. Below the screen are several buttons: a left arrow, a 'no spark' icon, a gear icon, a warning icon, and a right arrow. A finger is shown pressing the gear icon.</p>
2	<p>Press and release the Up/Down arrow keys to select register 138. For a detailed description of available registers refer to <a href="#">Table 7.18 Power Supply Registers</a>.</p>	 <p>The image shows the control panel with the LCD displaying '138'. The '#' icon is still present. A finger is shown pressing the right arrow button.</p>
3	<p>Once you have reached register 138, press the Configuration key. The register value will be displayed; this is indicated by the circle icon.</p>	 <p>The image shows the control panel with the LCD displaying '138'. The '#' icon has been replaced by a circle icon. A finger is shown pressing the gear icon.</p>

**Table 7.2** Continuous Mode Operational Sequence

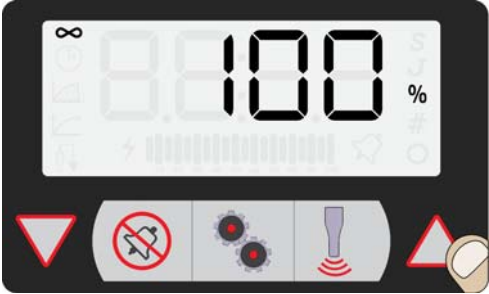
Step	Action	Reference
4	Use the Up/Down arrow keys to select value 0 (Continuous mode), then press the Configuration key to confirm the selection.	
5	Continuous mode icon and amplitude value will be displayed.	





## 7.1.2 Selecting Time Mode

You can use Time Mode to select the length of time that ultrasonic energy is applied to your parts. Within Time Mode, you can also select several other parameters, ranging from afterburst to limits and cutoffs. For more information on setting the optional parameters within Time Mode, or any other welding mode, refer to the DCX A/F Series Web Page Instruction Manual.

**Table 7.3** Time Mode Parameters

Parameter	Default	Max. Value	Min. Value
Time	0.010 seconds	30 seconds	0.010 seconds

**Table 7.4** Selecting Time Mode

Step	Action	Reference
1	Press the Configuration key until the number icon (#) appears on the LCD. The power supply will display register 101 at every power up.	
2	Press and release the Up/Down arrow keys to select register 138. For a detailed description of available registers refer to <a href="#">Table 7.18 Power Supply Registers</a> .	
3	Once you have reached register 138, press the Configuration key. The register value will be displayed; this is indicated by the circle icon.	

**Table 7.4** Selecting Time Mode

Step	Action	Reference
4	Use the Up/Down arrow keys to select value 1 (Time mode), then press the Configuration key to confirm the selection.	

## 7.1.2.1 Setting Time Mode Parameters

**Table 7.5** Setting Time Mode Parameters

Step	Action	Reference
1	Set the Power Supply to Time Mode.	See <a href="#">7.1.2 Selecting Time Mode</a> .
2	Time mode icon and parameter value will be displayed. Use the Up/Down keys to enter the desired parameter value.	



## 7.1.3 Selecting Energy Mode

You can use Energy Mode to select the amount of ultrasonic energy that is applied to your parts. Within Energy Mode, you can also select several other parameters, ranging from afterburst to limits and cutoffs. For more information on setting the optional parameters within Energy Mode, or any other welding mode, refer to the DCX A/F Series Web Page Instruction Manual.

**Table 7.6** Energy Mode Parameters

Parameter	Default	Max. Value	Min. Value
Energy	500 Joules	9999 Joules	0.1 Joules

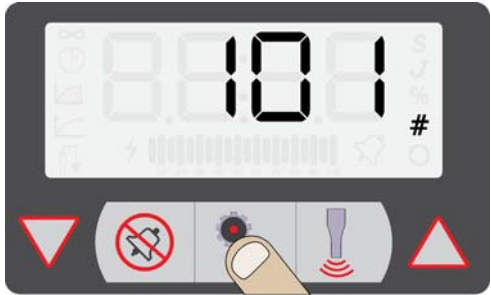
**Table 7.7** Selecting Energy Mode

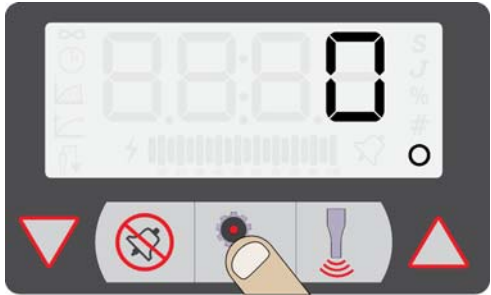
Step	Action	Reference
1	<p>Press the Configuration key until the number icon (#) appears on the LCD.</p> <p>The power supply will display register 101 at every power up.</p>	
2	<p>Press and release the Up/Down arrow keys to select register 138. For a detailed description of available registers refer to <a href="#">Table 7.18 Power Supply Registers</a>.</p>	
3	<p>Once you have reached register 138, press the Configuration key. The register value will be displayed; this is indicated by the circle icon.</p>	

**Table 7.7** Selecting Energy Mode

Step	Action	Reference
4	Use the Up/Down arrow keys to select value 2 (Energy mode), then press the Configuration key to confirm the selection.	 <p>The screenshot shows a digital display with '2' in the center. To the left of the display are icons for a graph, a lightning bolt, and a gear. To the right are icons for a percentage sign, a hash symbol, and a circle. Below the display is a control panel with a left arrow, a 'no touch' icon, a gear icon (being pressed by a finger), a warning icon, and a right arrow.</p>

### 7.1.3.1 Setting Energy Mode Parameters

**Table 7.8** Setting Energy Mode Parameters

Step	Action	Reference
1	Set the Power Supply to Energy Mode.	See <a href="#">7.1.3 Selecting Energy Mode</a> .
2	Energy mode icon and parameter value will be displayed. Use the Up/Down keys to enter the desired parameter value.	 <p>The screenshot shows a digital display with '5000.0 J' in the center. To the left of the display is a graph icon. To the right are icons for a lightning bolt, a percentage sign, a hash symbol, and a circle. Below the display is a control panel with a left arrow, a 'no touch' icon, two gear icons, a warning icon, and a right arrow.</p>



## 7.1.4 Selecting Peak Power Mode

You can use Peak Power Mode to select the maximum percentage of the total available power that will be used to process your welds. When the power level you set is reached, ultrasonics will be terminated. From within Peak Power Mode, you can also select several other parameters, ranging from afterburst to limits and cutoffs. For more information on setting the optional parameters within Peak Power Mode, or any other welding mode, refer to the DCX A/F Series Web Page Instruction Manual.

**Table 7.9** Peak Power Mode Parameters

Parameter	Default	Max. Value	Min. Value
Peak Power	1%	100%	1%

**Table 7.10** Selecting Peak Power Mode

Step	Action	Reference
1	Press the Configuration key until the number icon (#) appears on the LCD. The power supply will display register 101 at every power up.	
2	Press and release the Up/Down arrow keys to select register 138. For a detailed description of available registers refer to <a href="#">Table 7.18 Power Supply Registers</a> .	
3	Once you have reached register 138, press the Configuration key. The register value will be displayed; this is indicated by the circle icon.	

**Table 7.10** Selecting Peak Power Mode

Step	Action	Reference
4	Use the Up/Down arrow keys to select value 3 (Peak Power mode), then press the Configuration key to confirm the selection.	

## 7.1.4.1 Setting Peak Power Mode Parameters

**Table 7.11** Setting Peak Power Mode Parameters

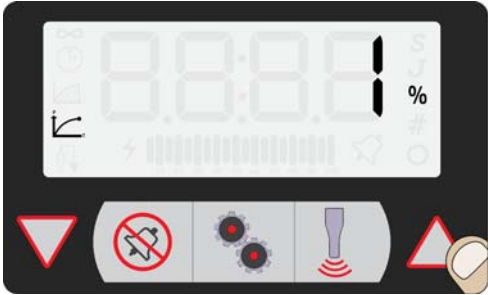
Step	Action	Reference
1	Set the power supply to peak power mode.	See <a href="#">7.1.4 Selecting Peak Power Mode</a> .
2	Peak Power mode icon and parameter value will be displayed. Use the Up/Down keys to enter the desired parameter value.	

## 7.1.5 Selecting Ground Detect Mode



You can use Ground Detect Weld Mode to have ultrasonic energy turn off when the horn comes in contact with your electrically isolated fixture or anvil.

From within Ground Detect Mode, you can also select several other parameters, ranging from Hold Time (in seconds) to Suspect and Reject Limits. For more information on setting the optional parameters within Ground Detect Mode, or any other welding mode, refer to the DCX A/F Series Web Page Instruction Manual.

**Table 7.12** Ground Detect Mode Parameters

Parameter	Default	Max. Value	Min. Value
Ground Detect	0.001 seconds	0.500 seconds	0.001 seconds

**Table 7.13** Selecting Ground Detect Mode

Step	Action	Reference
1	<p>Press the Configuration key until the number icon (#) appears on the LCD.</p> <p>The power supply will display register 101 at every power up.</p>	
2	<p>Press and release the Up/Down arrow keys to select register 138. For a detailed description of available registers refer to <a href="#">Table 7.18 Power Supply Registers</a>.</p>	
3	<p>Once you have reached register 138, press the Configuration key. The register value will be displayed; this is indicated by the circle icon.</p>	

**Table 7.13** Selecting Ground Detect Mode

Step	Action	Reference
4	Use the Up/Down arrow keys to select value 4 (Ground Detect mode), then press the Configuration key to confirm the selection.	

### 7.1.5.1 Setting Ground Detect Mode Parameters

**Table 7.14** Setting Ground Detect Mode Parameters

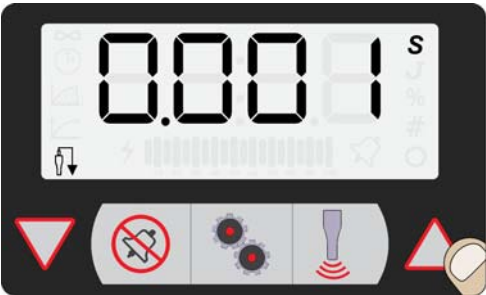
Step	Action	Reference
1	Set the Power Supply to Ground Detect Mode.	See <a href="#">7.1.5 Selecting Ground Detect Mode</a> .
2	Ground Detect mode icon and parameter value will be displayed. Use the Up/Down keys to enter the desired parameter value.	



## 7.2 Setting the Amplitude

### 7.2.1 Using the Front Panel Controls

At power up the DCX F-EIP Power Supply will display the last amplitude setting on the LCD. It can also be set to show weld mode.

**Figure 7.1** LCD at Power Up



**Table 7.15** Setting the Amplitude Using the Front Panel Controls

Step	Action	Reference
1	Press the Configuration key until the percentage icon (%) and no mode icons are displaying on the LCD.	
2	<p>Press and release the Up or Down arrow keys to select the desired amplitude at 1% increments.</p> <p>Press and hold down the Up or Down arrow keys and the Amplitude will auto increment at 1% increments every quarter of a second.</p> <p>After holding down an arrow key for four straight seconds, the amplitude will auto increment at 5% increments every quarter of a second.</p>	

## 7.2.2 Using External Amplitude Control

When External Amplitude Control is enabled, the front panel amplitude control is disabled and the LCD displays four dashes (see [Figure 7.2 LCD when in External Amplitude Control Mode](#) below).

**Figure 7.2** LCD when in External Amplitude Control Mode

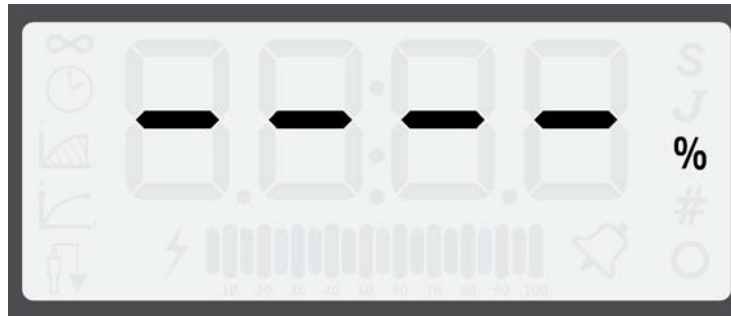

The ultrasonic amplitude can be controlled using one of the two analog input pins on the user I/O connector (pins 17 and 18) or through the Ether/Net IP interface.

## 7.2.3 Using the Web Page Interface

The ultrasonic amplitude can be set to a user specified value using the web page interface. For more information, refer to the DCX A/F Series Web Page Instruction Manual.

## 7.3 Resetting the Power Supply Alarms

You need to reset the weld system when you get an overload. When there is an overload, the alarm icon appears on the front panel LCD and the General Alarm output on the user I/O connector becomes active. The procedure for resetting the power supply depends on the power supply alarm settings. Refer to [Table 7.16 Resetting the DCX F-EIP Power Supply](#) for reset procedures.

**Table 7.16** Resetting the DCX F-EIP Power Supply



Alarm Setting	Reset Procedure
Reset Required	Press the front panel Reset key. You can also send an External Reset signal.
No Reset Required	Remove and re-apply the start signal.

For more information on interfacing the DCX F-EIP Power Supply using the user I/O connections refer to [5.3.6 User I/O Connections](#) in [Chapter 5: Installation and Setup](#).



## 7.4 Configuring the Power Supply Registers

At power up the DCX F-EIP Power Supply will display the last amplitude setting, this is indicated by the percentage icon (%) on the LCD. Refer to [Figure 7.1 LCD at Power Up](#).

**Table 7.17** Steps to Configure the Power Supply Registers

Step	Action	Reference
1	<p>Press the Configuration key until the number icon (#) appears on the LCD.</p> <p>The power supply will display register 101 at every power up.</p>	 <p>The image shows the LCD display with the number '101' and a '#' icon on the right. Below the display are several control buttons: a left arrow, a 'no touch' icon, a red dot icon, a warning bell icon, and a right arrow. A finger is shown pressing the red dot icon.</p>
2	<p>Press and release the Up or Down arrow keys to select the desired register. For a detailed description of available registers refer to <a href="#">Table 7.18 Power Supply Registers</a>.</p>	 <p>The image shows the LCD display with the number '108' and a '#' icon on the right. Below the display are the same control buttons as in the previous image. A finger is shown pressing the right arrow button.</p>
3	<p>Once you have reached the desired register, press the Configuration key. The register value will be displayed, this is indicated by the circle icon.</p>	 <p>The image shows the LCD display with the number '80' and a circle icon on the right. Below the display are the same control buttons. A finger is shown pressing the red dot icon.</p>

**Table 7.17** Steps to Configure the Power Supply Registers

Step	Action	Reference
4	<p>Press and release the Up or Down arrow keys to enter the desired value at 1 increments.</p> <p>Press and hold down the Up and Down arrow keys and the value will auto increment at 1 increments every quarter of a second.</p> <p>After holding down an arrow key for four straight seconds, the value will auto increment at 5 increments every quarter of a second.</p> <p>Or press the Reset key to enter the default value. For detailed default values of available registers refer to <a href="#">Table 7.18 Power Supply Registers</a>.</p>	 <p>The image shows a digital display with the number 150. The display has various icons around it, including a power button, a warning sign, and a reset button. A hand is shown pressing the reset button.</p>
5	<p>Press the Configuration key to save the value. The current amplitude setting will be displayed only for continuous mode. For all the other modes, it will display the primary parameter of that mode.</p>	 <p>The image shows a digital display with the number 100%. The display has various icons around it, including a power button, a warning sign, and a reset button. A hand is shown pressing the configuration key.</p>

## 7.4.1 Power Supply Registers

**Table 7.18** Power Supply Registers

Register	Description	Min. Value	Max. Value	Default Value
101	Software version	N/A	N/A	N/A
102	Bar graph identification after weld complete 0=Power 1=Frequency	0	1	0
104	External amplitude control - user analog input or fieldbus 0=Off 1=On	0	1	0
105	Start ramp time (ms)	10	1000	80
106	Store frequency at end of weld 0=Off 1=On	0	1	1
107	Power up seek/scan 0=Off 1=Seek, 2=Scan	0	2	1
108	Seek ramp time (ms)	10	1000	80
109	Timed seek (every 60 seconds) 0=Off 1=On	0	1	0
110	Seek time (ms)	10	1000	500
111	External Frequency Offset 0=Off 1=On	0	1	0
112	Frequency Offset Value			0
113	Cutoffs 0=Off 1=On	0	1	0
114	Limits 0=Off 1=On	0	1	0

**Table 7.18** Power Supply Registers

Register	Description	Min. Value	Max. Value	Default Value
115	Restore Defaults 0=Off 1=Just weld preset 2=System defaults	0	2	0
116	IP Address - 1	0	255	192
117	IP Address - 2	0	255	168
118	IP Address - 3	0	255	10
119	IP Address - 4	0	255	100
120	Gateway for IP Address - 1	0	255	192
121	Gateway for IP Address - 2	0	255	168
122	Gateway for IP Address - 3	0	255	10
123	Gateway for IP Address - 4	0	255	1
124	Subnet Mask for IP Address - 1	0	255	255
125	Subnet Mask for IP Address - 2	0	255	255
126	Subnet Mask for IP Address - 3	0	255	255
127	Subnet Mask for IP Address - 4	0	255	0
128	DHCP Settings 0=Server 1=Client 2=Static 3=Restore Registers 116-128 to default	0	3	2
134	Backlight Timeout (s) 0=Always on	0	9999	600
135	Auto scroll step size	1	50	5
136	Power on display 0=Weld Mode 1=Amplitude	0	1	1
138	Weld Mode 0=Continuous 1=Time 2=Energy 3=Peak Power 4=Ground Detect	0	4	0
139	MAC Address 1	0	FFFF	N/A

**Table 7.18** Power Supply Registers

Register	Description	Min. Value	Max. Value	Default Value
140	MAC Address 2	0	FFFF	N/A
141	MAC Address 3	0	FFFF	N/A
142	Ethernet IP Address - 1	0	255	192
143	Ethernet IP Address - 2	0	255	168
144	Ethernet IP Address - 3	0	255	10
145	Ethernet IP Address - 4	0	255	101
146	Gateway for Ethernet IP Address - 1	0	255	192
147	Gateway for Ethernet IP Address - 2	0	255	198
148	Gateway for Ethernet IP Address - 3	0	255	10
149	Gateway for Ethernet IP Address - 4	0	255	1
150	Subnet Mask for Ethernet IP Address - 1	0	255	255
151	Subnet Mask for Ethernet IP Address - 2	0	255	255
152	Subnet Mask for Ethernet IP Address - 3	0	255	255
153	Subnet Mask for Ethernet IP Address - 4	0	255	0
154	Restore registers 142–153 to default.	0	1	0



## 7.5 LCD Bar-Graph

While ultrasonic power is active the LCD will always display the power value on the 20-segment LCD bar-graph as a percentage of the maximum output power.

At the end of a weld or test cycle, the bar-graph is factory set to represent the cycle's peak power as a percentage of the maximum output power.

The power supply can also be configured to show a single bar on the LCD bar-graph to represent the stack operating frequency stored at the end of each weld or test cycle. This option can be used to troubleshoot operating frequency changes as a result of heating effects, coupling, tooling wear, etc.

For information on how to set the power supply registers see [7.4 Configuring the Power Supply Registers](#).

### 7.5.1 Power Bar-Graph Interpretation

The lightning bolt left of the bar-graph indicates ultrasonic power is running. Each of the segments represent 5% increments of the maximum output power. The segments will only appear if the output power has exceeded the value represented. For example if the power is 4% only the lightning bolt will be on. When it reaches 5% the first bar-graph segment will appear.

**Table 7.19** Power Bar-Graph Interpretation Examples

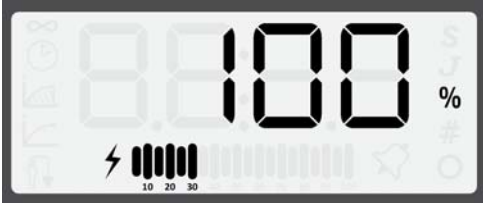
Description	Reference
<p>In this example only the lightning bolt appears left of the bar-graph. This means power is between 0% and 5%. If the power supply is 800 W the actual output power is between 0 W and 40 W.</p>	 <p>The image shows a digital LCD display with the number '100' and a '%' symbol on the right. On the left side, there is a lightning bolt icon and a bar graph consisting of 20 segments, all of which are currently empty.</p>
<p>In this example the first six segments appear on the bar-graph. This means power is between 30% and 35%. If the power supply is 800 W, the actual output power is between 240 W and 280 W.</p>	 <p>The image shows a digital LCD display with the number '100' and a '%' symbol on the right. On the left side, there is a lightning bolt icon and a bar graph consisting of 20 segments. The first six segments from the left are filled, while the remaining 14 segments are empty.</p>

## 7.5.2 Frequency Bar-Graph Interpretation

The actual frequency depends on the power supply's operating frequency. Use [Table 7.20](#) to [Table 7.22](#) below to interpret frequency bar-graph readings.

NOTICE	
	<p>If there is a test overload or an external memory reset signal is received, then the 50% segment will be displayed and blinking.</p>

**Table 7.20** Frequency Bar-Graph Interpretation - 20 kHz (50 Hz Segment)

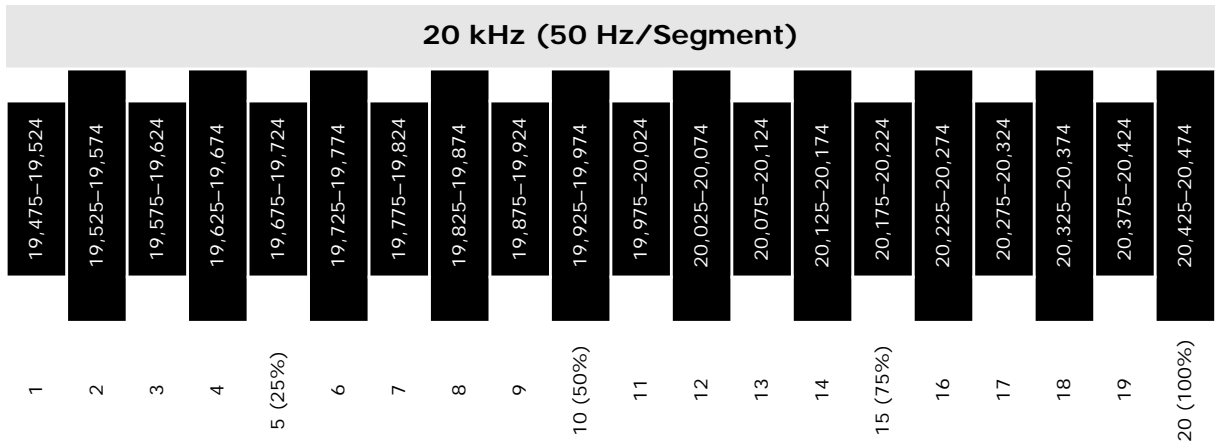

**Table 7.21** Frequency Bar-Graph Interpretation - 30 kHz (76 Hz Segment)

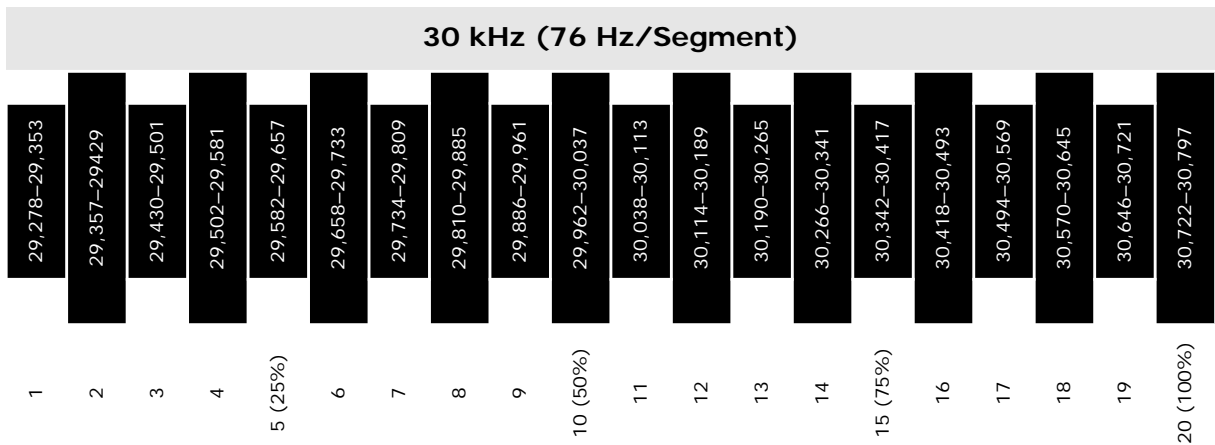

**Table 7.22** Frequency Bar-Graph Interpretation - 40 kHz (100 Hz/Segment)

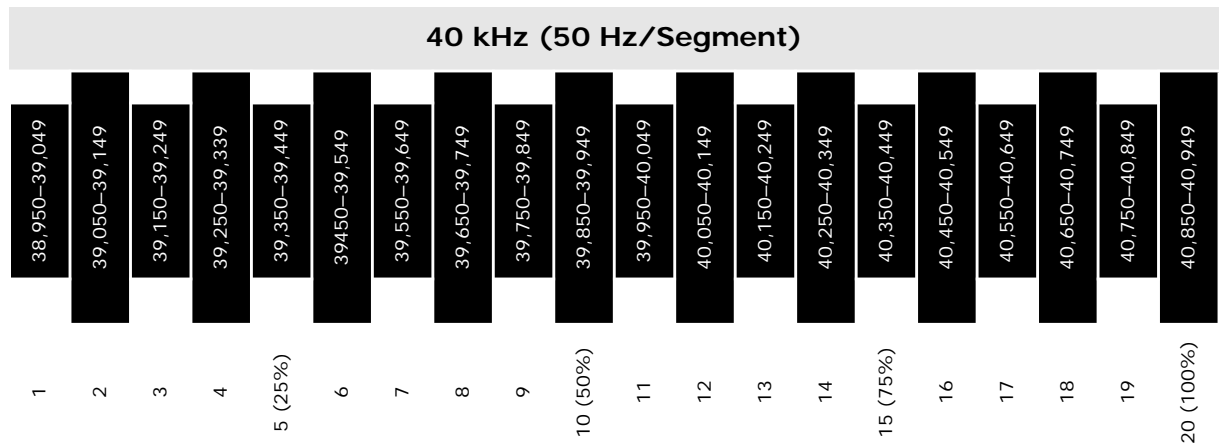



**Table 7.23** Frequency Bar-Graph Interpretation Examples

Description	Reference
<p>In this example the bar is located in the 11<sup>th</sup> segment. If the power supply is a 20 kHz unit, the stack is running in the frequency range of 19,975 Hz to 20,024 Hz.</p>	
<p>In this example the bar is located in the 7<sup>th</sup> segment. If the power supply is a 20 kHz unit, the stack is running in the frequency range of 19,775 Hz to 19,824 Hz.</p>	

## 7.6 Ultrasonics Test Procedure

The Ultrasonics Test function measures ultrasonic power dissipated by the ultrasonic stack with no load. The ultrasonics test procedure involves an automatic matching of the frequency of the power supply to the frequency of the converter-booster-horn stack.

WARNING	High Voltage Hazard
	<p>Ensure that no one is in contact with the horn when testing the power supply.</p> <p>Do not cycle the welding system if either the RF cable or converter is disconnected.</p>

WARNING	High Voltage Hazard
	<p>Ensure the power supply is properly connected, as indicated in <a href="#">5.3 Installation Steps</a>.</p>

### 7.6.1 Using the Front Panel Controls

NOTICE	
	<p>To use the front panel controls, the DCX F-EIP Power Supply unit must be in manual mode.</p>

**Table 7.24** Power Supply Ultrasonic Test Procedure (Front Panel)

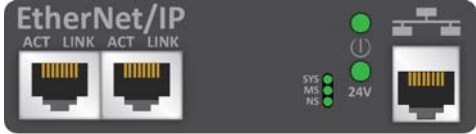

Step	Action	Reference
1	Turn on the power supply and 24 V. The front panel Power LED and LCD turn on.	

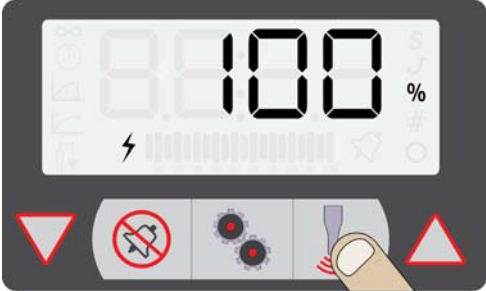
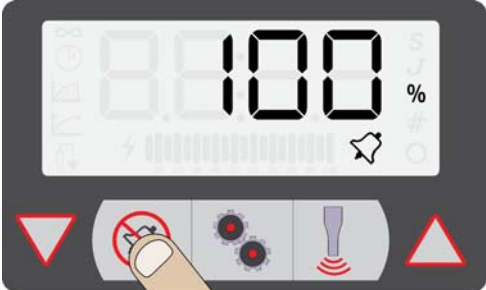
**Table 7.24** Power Supply Ultrasonic Test Procedure (Front Panel)

Step	Action	Reference
2	<p>Press the test key for 1-2 seconds, then release. The Sonics Active indicator appears while the test key is pressed. If the power supply alarm indicator does not appear, the test procedure is finished.</p>	 <p>The image shows the front panel of a Branson ultrasonic test device. The digital display shows '100%' with a lightning bolt icon below it. Below the display are several control buttons: a red triangle, a button with a crossed-out lightning bolt, a gear icon, a button with a lightning bolt and sound waves, and another red triangle. A hand is shown pressing the button with the lightning bolt and sound waves.</p>
3	<p>If the alarm indicator appears, press the alarm reset key and repeat step 2 one time only. If the alarm persists, refer to <a href="#">9.5 Troubleshooting</a>. See <a href="#">Appendix A: Alarms</a> for additional information.</p>	 <p>The image shows the front panel of the same device. The digital display shows '100%' with a starburst alarm icon below it. The control buttons are the same as in the previous image, but now a hand is shown pressing the button with the crossed-out lightning bolt.</p>

## 7.7 Using the I/O Connections

**Table 7.25** Power Supply

Step	Action	Reference
1	Wire the necessary I/O signals as shown on <a href="#">Figure 7.3 Test Connections</a> , or using a similar setup.	Refer to <a href="#">Figure 7.3 Test Connections</a> below.
2	Turn on the power supply and 24 V. The front panel Power LED should turn on. Ready Signal should become active.	
3	Send an External Test signal for 1-2 seconds. The Sonics Active output will become active and the Sonics Active indicator appears while the External Start Signal is present. If the General Alarm output/ alarm indicator does not become active, the test procedure is finished.  <div style="background-color: #004a99; color: white; padding: 2px; display: inline-block;"><b>NOTICE</b></div> Power supply must be in manual mode.	
4	If the General Alarm output/alarm indicator becomes active, send an External Reset signal and repeat step 2 one time only. If the alarm persists, refer to <a href="#">9.5 Troubleshooting</a> .	

**Figure 7.3** Test Connections

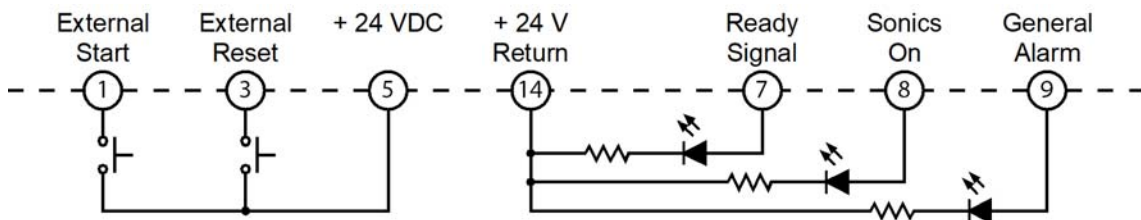

---

## Chapter 8: EtherNet/IP Operation

---

8.1	EtherNet/IP . . . . .	124
8.2	EtherNet/IP Overview . . . . .	127
8.3	Message Type Definitions . . . . .	128
8.4	Communication to the CompactLogix Via EtherNet/IP . . . . .	129
8.5	Implicit Messaging . . . . .	133
8.6	Explicit Messaging . . . . .	146
8.7	Implicit Messaging . . . . .	153
8.8	Implicit Messaging Live Channel . . . . .	163

## 8.1 EtherNet/IP

The DCX F-EIP Power Supply is controlled via a EtherNet/IP interface. The parameters of the DCX F-EIP Power Supply, for example, are also configured via EtherNet/IP.

The number of EtherNet/IP slaves to be set up is limited to max. 125 stations, due to the standardized interface layout.

### 8.1.1 LED Status Indicator

To get a fast overview about the status of the DCX F-EIP Power Supply, three LEDs are placed on the front of the unit. The subsequent table describes the meaning of the LEDs.

**Figure 8.1** LED Status Indicator

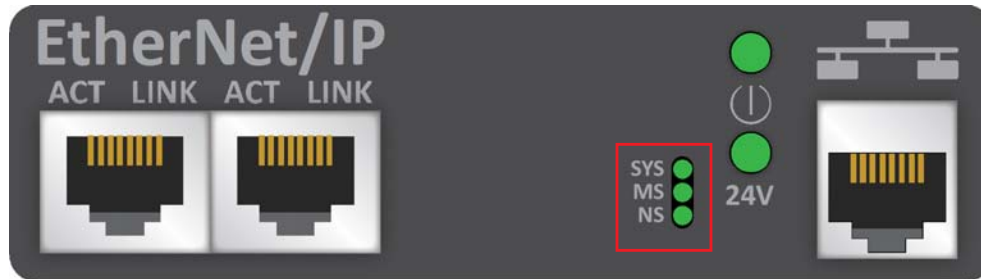

**Table 8.1** DCX F-EIP Power Supply LED Status Indicator

LED	Color	State	Description
SYS	Green	On	Operating System running.
	Green/ Yellow	Blinking green/yellow	Bootloader is waiting for firmware.
	Yellow	Static	Bootloader is waiting for software.
	-	Off	Power supply for the device is missing or hardware defect.



**Table 8.1** DCX F-EIP Power Supply LED Status Indicator

LED	Color	State	Description
MS	Green	On	<b>Device operational:</b> If the device is operating correctly, the module status indicator will be steady green.
	Green	Flashing	<b>Standby:</b> If the device has not been configured, the module status indicator will be flashing green.
	Red	On	<b>Major fault:</b> If the device has detected a non-recoverable major fault, the module status indicator will be steady red.
	Red	Flashing	<b>Minor fault:</b> If the device has detected a recoverable minor fault, the module status indicator will be flashing red.  An incorrect or inconsistent configuration would be considered a minor fault.
	Green/Red	Flashing	<b>Self-test:</b> While the device is performing its power up testing, the module status indicator will be flashing green/red.
	-	Off	<b>No power:</b> If no power is supplied to the device, the module status indicator will be steady off.
NS	Green	On	<b>Connected:</b> If the device has at least one established connection, the network status indicator will be steady green.
	Green	Flashing	<b>No connection:</b> If the device has no established connections, but has obtained an IP address, the network status indicator will be flashing green.
	Red	On	<b>Duplicate IP:</b> If the device has detected that its IP address is already in use, the network status indicator will be steady red.
	Red	Flashing	<b>Connection timeout:</b> If one or more of the connections in which this device is the target has timed out, the network status indicator will be flashing red.
	Green/Red	Flashing	<b>Self-test:</b> While the device is performing its power up testing, the network status indicator will be flashing green/red.
	-	Off	<b>Not powered, no IP address:</b> If the device does not have an IP address or is powered off, the network status indicator will be off.

## 8.1.2 EtherNet/IP Specifications

The EtherNet/IP interface has the following technical specifications:

- Maximum number of input data: 504 bytes
- Maximum number of output data: 504 bytes
- IO Connection: 1 explicit owner, up to 2 listen only
- IO Connection type: Cyclic, minimum 1 ms
- Maximum number of connections: 8, explicit and implicit connections
- UCMM (Unconnected Message Manager): Supported
- Explicit Messages: Get\_Attribute, Set\_Attribute
- Predefined standard objects: Identity Object, Message Route Object, Assembly Object, Connection Manager, Ethernet Link Object, TCP/P Object, DLR Object
- Maximum number of user specific objects: 20
- DHCP: Supported
- BOOTP: Supported
- Baud Rates: 10 and 100 MBit/Sec
- Data transport layer: Ethernet II, IEEE802.3
- ACD (Address conflict detection): Supported
- DLR (Device level ring) (Ring topology): Supported
- Integrated switch: Supported

## 8.2 EtherNet/IP Overview

NOTICE	
	<p>This section assumes that the user has a fundamental understanding of the various Rockwell PLC platforms and Rockwell software packages. It is not intended to be an instructional manual for the above items.</p> <p>Because of the variety of uses for the products described in this publication, those responsible for the application and use of this equipment must satisfy themselves that all necessary steps have been taken to assure that each application and use meets all performance and safety requirements, including any applicable laws, regulations, codes and standards. The illustrations, charts, sample programs and layout examples shown in this section are intended solely for purposes of example. Since there are many variables and requirements associated with any particular installation, Branson does not assume responsibility or liability for actual use based upon the examples shown in this publication.</p>

### 8.2.1 Industrial Ethernet Protocol

The Industrial Ethernet Protocol (EtherNet/IP) was originally developed by Rockwell Automation and is now managed by the Open DeviceNet Vendors Association (ODVA). It is a well-established Industrial Ethernet communication system with Real-Time capabilities. EtherNet/IP has a strong presence in America and Asia and has been selected by many major manufacturers as a plant wide communication system for factories worldwide. EtherNet/IP is standardized in the International standard IEC 61158 and EtherNet/IP devices are certified by ODVA for interoperability and conformance.

EtherNet IP extends commercial off-the-shelf Ethernet to the Common Industrial Protocol (CIP) — the same upper-layer protocol and object model found in DeviceNet and ControlNet. CIP allows EtherNet/IP and DeviceNet system integrators and users to apply the same objects and profiles for plug-and-play interoperability among devices from multiple vendors and in multiple sub-nets. Combined, DeviceNet, ControlNet and EtherNet/IP promote transparency from sensors to the enterprise software.

### 8.2.2 Common Industrial Protocol (CIP)

CIP provides a wide range of standard objects and services for access to data and for control of network devices via so called “implicit” and “explicit” messages. The CIP data packets are encapsulated before they will be send with standard TCP or UDP telegrams on the Ethernet.

EtherNet/IP uses all the transport and control protocols of standard Ethernet including the Transport Control Protocol (TCP), the User Datagram Protocol (UDP), the Internet Protocol (IP) and the media access and signaling technologies found in off-the-shelf Ethernet technology. Building on these standard communication technologies means that EtherNet/IP works transparently with all the standard Ethernet devices found in today's market place. It also means that EtherNet/IP automatically benefits from all further technology enhancements such as Gigabit Ethernet and Wireless technologies.

## 8.3 Message Type Definitions

### 8.3.1 Explicit Message

Explicit messages contain addressing and service information that directs the receiving device to perform a certain service (action) on a specific part (e.g., an attribute) of a device. Explicit message data can be sent or received from any available instance in the EtherNet/IP device being communicated to. Explicit messages allow for easy management of different data types.

### 8.3.2 Implicit (I/O) Message

Implicit messages do not carry address and/or service information; the consuming node(s) already know what to do with the data based on the connection ID that was assigned when the connection was established. Implicit messages are so named because the meaning of the data is implied by the connection ID. When an Implicit message procedure is setup for a specific device. All data sent to or received from the device must be of the same type.

## 8.4 Communication to the CompactLogix Via EtherNet/IP

The purpose of this section is to describe the configuration steps necessary to establish a communication path between the DCX F-EIP Power Supply and a CompactLogix unit. For this example, you will need a 1769-L32E together with a CompactLogix Controller. You will also need Rockwell Software's RSLinx and RSLogix 5000 software configuration utilities.

NOTICE	
	<p>The network parameters used in this example will almost certainly not apply to your application. Be sure to consult your network administrator when selecting appropriate values.</p>

### 8.4.1 Generic Module Configuration

1. Run the RSLogix 5000 program and create a New File.

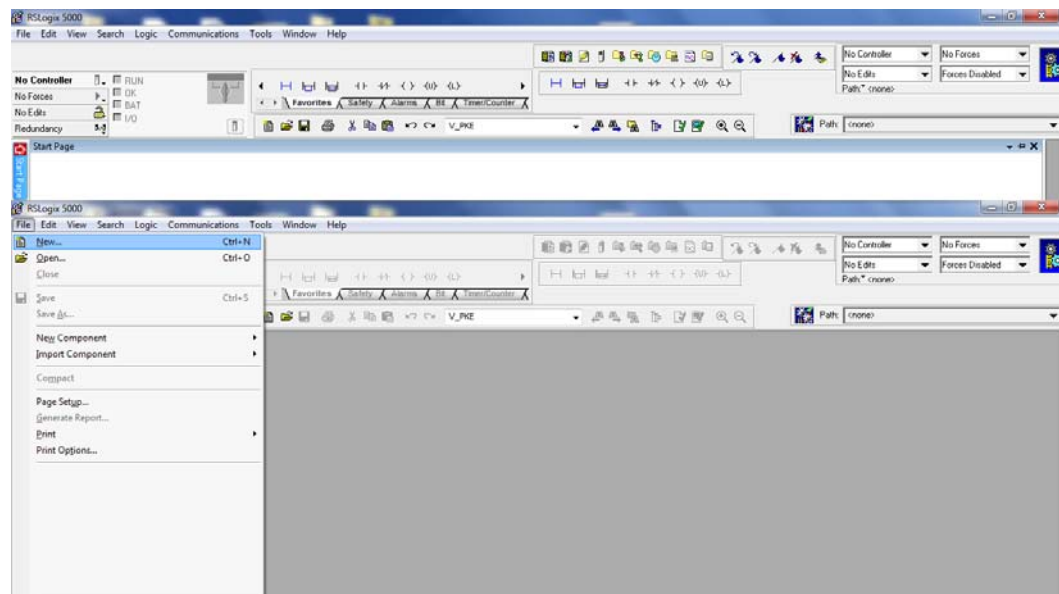

2. On the New Controller dialog box, select the Type of the controller 1769-L32E and enter a Name to identify the controller. The controller will be added to the I/O Configuration node in the Controller Organizer view.

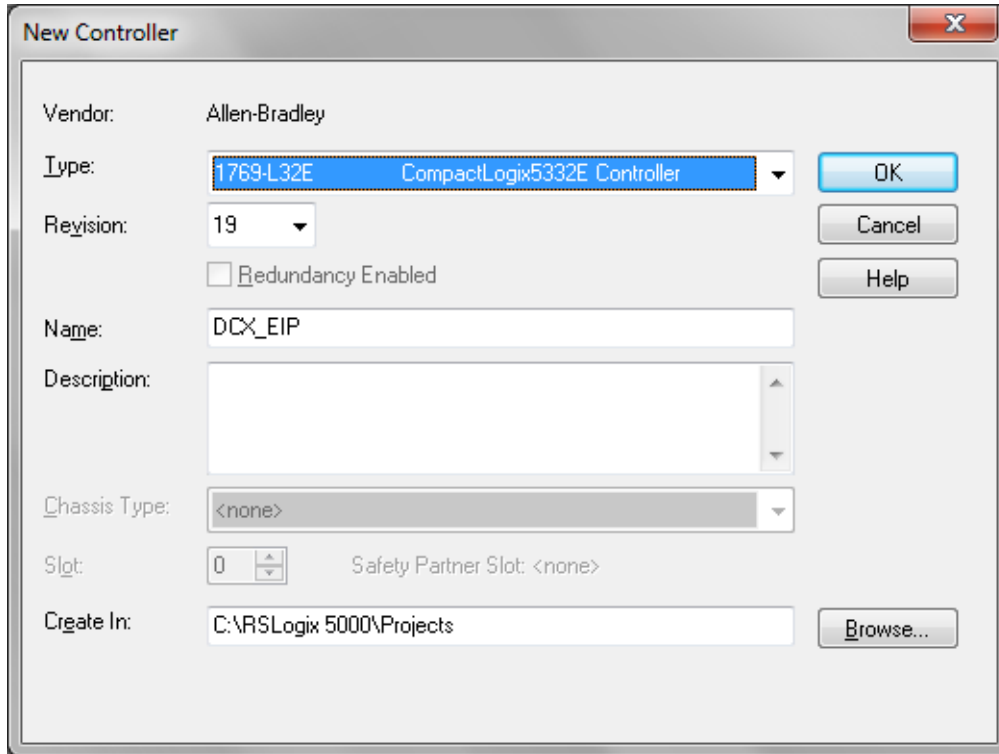

3. Right click on the 1769-L32E node in the Controller Organizer view and choose Add Module.

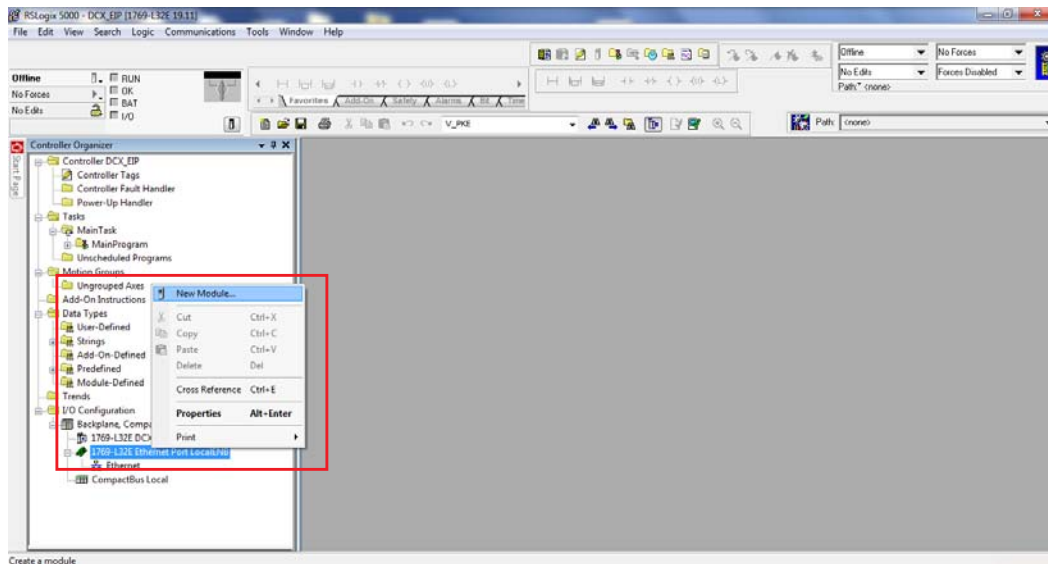

- On the Select Module dialog box, select the ETHERNET-MODULE Generic Ethernet Module and click OK.

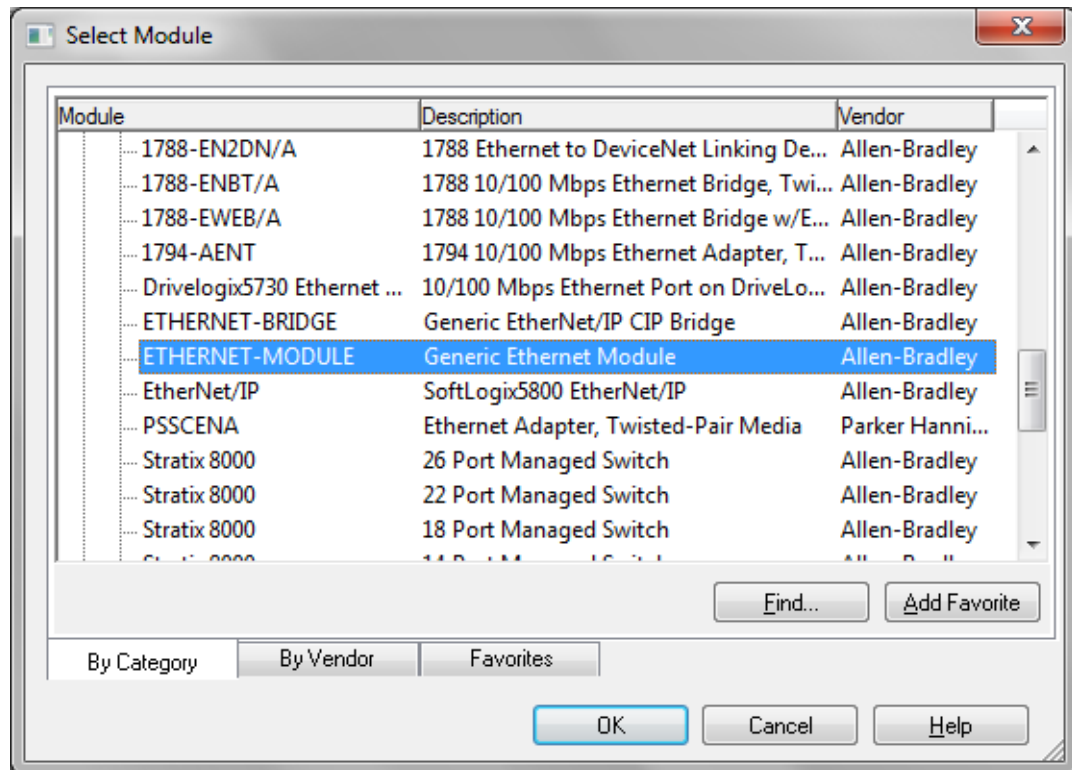

- This will open the Module Properties dialog box.

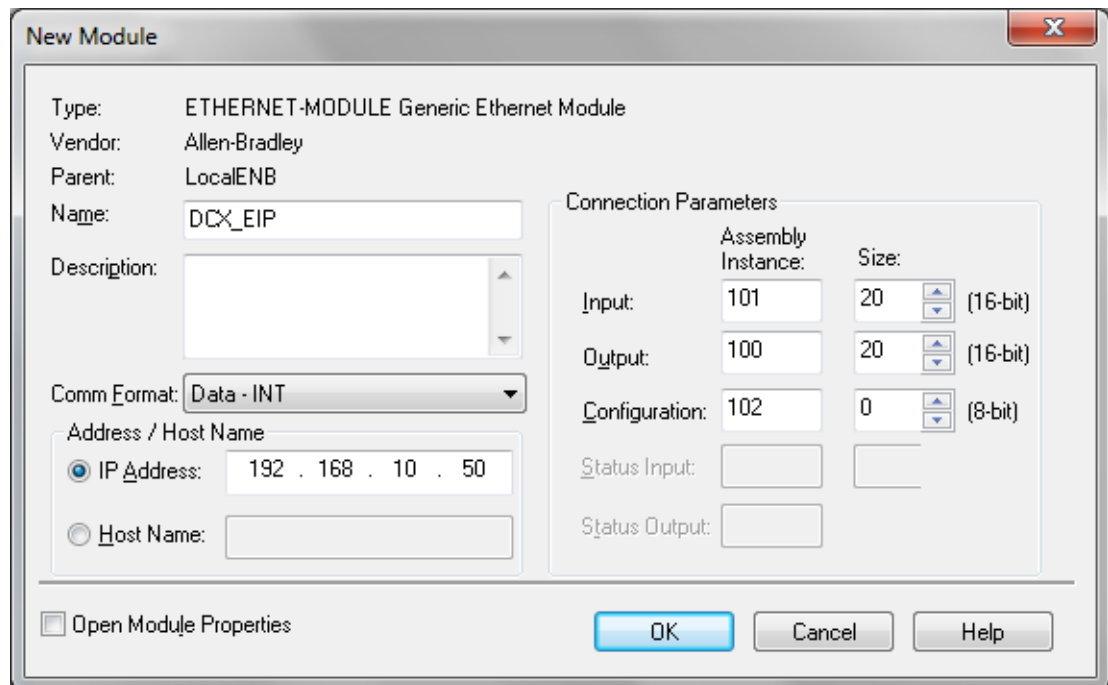

- In the Name, enter a descriptive name to identify the module
- Select Data - INT on the Comm Format menu
- In the Address/Host Name, enter the IP Address of the DCX F-EIP Power Supply unit

- Enter 101 in the Input Assembly Connection Point and a size of 20. This will match a read only Slave Gateway block configured in the DCX F-EIP Power Supply, and will be used for reading data from the DCX F-EIP Power Supply to the CompactLogix
- Enter 100 in the Output Assembly Connection Point and a size of 20. This will match a read/write Slave Gateway block configured in the DCX F-EIP Power Supply, and will be used for writing data from the CompactLogix to the DCX F-EIP Power Supply
- Enter 102 in the Configuration Connection Point and a size of 0
- Press Finish to add the DCX F-EIP Power Supply to the I/O configuration



## 8.5 Implicit Messaging

### 8.5.1 I/O Setup for EtherNet/IP Module With Standard Configuration

Figure 8.2 I/O Setup for EtherNet/IP Module With Standard Configuration

The screenshot shows a 'New Module' dialog box with the following configuration:

- Type: ETHERNET-MODULE Generic Ethernet Module
- Vendor: Allen-Bradley
- Parent: LocalENB
- Name: DCX\_EIP
- Description: (empty text area)
- Comm Format: Data - INT
- Address / Host Name:
  - IP Address: 192 . 168 . 10 . 50
  - Host Name: (empty text field)
- Connection Parameters:

	Assembly Instance:	Size:	
Input:	101	20	(16-bit)
Output:	100	20	(16-bit)
Configuration:	102	0	(8-bit)
Status Input:			
Status Output:			

At the bottom, there is a checkbox for 'Open Module Properties' (unchecked) and three buttons: 'OK', 'Cancel', and 'Help'.

## 8.5.2 DCX Inputs/PLC Outputs (8 bytes)

**Table 8.2** DCX Inputs/PLC Outputs (8 bytes)

Data	Description	Data Type	Access	Unit	Notes
0	STW1 (STW Word 1)	UINT16	W	-	See <a href="#">Table 8.3</a> and <a href="#">Table 8.6</a>
1	SWT2 (STW Word 2)			-	
2	External Amplitude			%	
3	Frequency Offset			Hz	

## 8.5.2.1 Control Word (STW1)

Table 8.3 Control Word (STW1)

	Bit	Name	Description	Notes
	0	RES	Reserved	Not used
	1	ES	Emergency Stop	1=Emergency Stop
	2	RES	Reserved	Not used
	3	RES	Reserved	Not used
	4	HFS0	Stack Preset Number 0	See <a href="#">Table 8.4 HFS Bit (Control Word)</a> .
	5	HFS1	Stack Preset Number 1	
	6	HFS2	Stack Preset Number 2	
	7	HFS3	Stack Preset Number 3	
	<p><b>NOTICE</b></p> <p>HFS stack presets numbers are feedback inputs to indicate RF relay switching state. This is used only in stack sequencing applications. Set HFS to 0 if not using stack sequencing.</p>			
STW1	8	PSN0	Weld Preset Number 0	See <a href="#">Table 8.5 PSN Bit (Control Word)</a> .
	9	PSN1	Weld Preset Number 1	
	10	PSN2	Weld Preset Number 2	
	11	PSN3	Weld Preset Number 3	
	12	PSN4	Weld Preset Number 4	
	<p><b>NOTICE</b></p> <p>Preset 0 is reserved for the running preset. When a preset number is recalled, it is copied to Preset 0 and becomes the running preset.</p>			
	13	RES	Reserved	Not used
	14	MA	Manual/Auto	Set and leave to 1 for implicit messaging control Set to 0 for discrete I/O control
	15	RES	Reserved	Not used

## HFS Bit (Control Word)

**Table 8.4** HFS Bit (Control Word)

HFS3	HFS2	HFS1	HFS0	Stack Selected
0	0	0	0	No stack change
0	0	0	1	1 (factory default)
0	0	1	0	2
0	0	1	1	3
0	1	0	0	4
0	1	0	1	5
0	1	1	0	6
0	1	1	1	7
1	0	0	0	8
1	0	0	1	9
1	0	1	0	10
1	0	1	1	11
1	1	0	0	12
1	1	0	1	13
1	1	1	0	14
1	1	1	1	15

## PSN Bit (Control Word)

**Table 8.5** PSN Bit (Control Word)

PSN4	PSN3	PSN2	PSN1	PSN0	Preset Selected
0	0	0	0	0	Previous preset
0	0	0	0	1	1
0	0	0	1	0	2
0	0	0	1	1	3
0	0	1	0	0	4
0	0	1	0	1	5
0	0	1	1	0	6
0	0	1	1	1	7
0	1	0	0	0	8
0	1	0	0	1	9

**Table 8.5** PSN Bit (Control Word)

PSN4	PSN3	PSN2	PSN1	PSN0	Preset Selected
0	1	0	1	0	10
0	1	0	1	1	11
0	1	1	0	0	12
0	1	1	0	1	13
0	1	1	1	0	14
0	1	1	1	1	15
1	0	0	0	0	16
1	0	0	0	1	17
1	0	0	1	0	18
1	0	0	1	1	19
1	0	1	0	0	20
1	0	1	0	1	21
1	0	1	1	0	22
1	0	1	1	1	23
1	1	0	0	0	24
1	1	0	0	1	25
1	1	0	1	0	26
1	1	0	1	1	27
1	1	1	0	0	28
1	1	1	0	1	29
1	1	1	1	0	30
1	1	1	1	1	31

## 8.5.2.2 Control Word (STW2)

**Table 8.6** Control Word (STW2)

	Bit	Name	Description	Notes
STW2	0	FCT	Weld Function	1 = To run ultrasonics in normal mode
	1	SFCT	Stack Function	See <a href="#">Table 8.12</a>
	2	SFCT0	Stack Function 0	
	3	SFCT1	Stack Function 1	
	4	SFCT2	Stack Function 2	
	5	RES	Reserved	Not used
	6	MCLR	Memory Clear	1 = Memory offset will be set to 0
	7	RES	Reserved	Not used
	8	RST	Reset	1 = Reset
	9	ON	Run Ultrasonics	1 = Will turn on ultrasonics based on combination of SFCT or FCT bits. See table below.
	10	RES	Reserved	Not used
	11	RES	Reserved	
	12	GNDDT	Ground Detect	1 = Ground has been detected
	13	APROF	Amplitude Profile	1 = Switch from amplitude 1 to amplitude 2
	14	RES	Reserved	Not used
15	RES	Reserved		

### 8.5.3 DCX Outputs/PLC Inputs (20 bytes)

**Table 8.7** DCX Outputs/PLC Inputs (20 bytes)

Data	Description	Data Type	Access	Unit	Notes
0	Reserved	UINT16	R		
1	Reserved				
2	ZSW1 (ZSW Word 1)			-	See <a href="#">Table 8.8</a> and <a href="#">Table 8.11</a>
3	ZSW2 (ZSW Word 2)			-	
4	Nominal Amplitude Set			%	
5	Amplitude Output			%	
6	Current			%	
7	Power	%			
8	Phase	INT16		°	
9	PWM	UINT16		%	
10	Frequency			Hz	
11	Temperature		C		

## 8.5.3.1 Status Word (ZSW1)

**Table 8.8** Status Word (ZSW1)

	Bit	Name	Description	Notes
ZSW1	0	NO-B	Non Cycle Overload Group B	1 = Non cycle overload has occurred
	1	ES	Emergency Stop Active	1 = Emergency stop active
	2	TEE	Future Use	Not used
	3	HFSE		
	4	HFS0	Stack Preset Number 0 Status	See <a href="#">Table 8.9 HFS Bit (Status Word)</a> .
	5	HFS1	Stack Preset Number 1 Status	
	6	HFS2	Stack Preset Number 2 Status	
	7	HFS3	Stack Preset Number 3 Status	
	8	PSN0	Weld Preset Number 0 Active	See <a href="#">Table 8.10 PSN Bit (Status Word)</a> .
	9	PSN1	Weld Preset Number 1 Active	
	10	PSN2	Weld Preset Number 2 Active	
	11	PSN3	Weld Preset Number 3 Active	
	12	PSN4	Weld Preset Number 4 Active	
	13	PSCA	Preset Change Complete	1 = Preset change complete
	14	MA	Manual/Auto Mode Active	1 = Auto Mode
15	OL-0	Overload Group 0	1 = Overload has occurred	



## HSF Bit (Status Word)

**Table 8.9** HFS Bit (Status Word)

HFS3	HFS2	HFS1	HFS0	Stack Active
0	0	0	0	Not valid
0	0	0	1	1
0	0	1	0	2
0	0	1	1	3
0	1	0	0	4
0	1	0	1	5
0	1	1	0	6
0	1	1	1	7
1	0	0	0	8
1	0	0	1	9
1	0	1	0	10
1	0	1	1	11
1	1	0	0	12
1	1	0	1	13
1	1	1	0	14
1	1	1	1	15

## PSN Bit (Status Word)

**Table 8.10** PSN Bit (Status Word)

PSN4	PSN3	PSN2	PSN1	PSN0	Preset Active
0	0	0	0	0	No preset active
0	0	0	0	1	1
0	0	0	1	0	2
0	0	0	1	1	3
0	0	1	0	0	4
0	0	1	0	1	5
0	0	1	1	0	6
0	0	1	1	1	7
0	1	0	0	0	8
0	1	0	0	1	9

**Table 8.10** PSN Bit (Status Word)

PSN4	PSN3	PSN2	PSN1	PSN0	Preset Active
0	1	0	1	0	10
0	1	0	1	1	11
0	1	1	0	0	12
0	1	1	0	1	13
0	1	1	1	0	14
0	1	1	1	1	15
1	0	0	0	0	16
1	0	0	0	1	17
1	0	0	1	0	18
1	0	0	1	1	19
1	0	1	0	0	20
1	0	1	0	1	21
1	0	1	1	0	22
1	0	1	1	1	23
1	1	0	0	0	24
1	1	0	0	1	25
1	1	0	1	0	26
1	1	0	1	1	27
1	1	1	0	0	28
1	1	1	0	1	29
1	1	1	1	0	30
1	1	1	1	1	31

## 8.5.3.2 Status Word (ZSW2)

Table 8.11 Status Word (ZSW2)

	Bit	Name	Description	Notes
ZSW2	0	SE-2	Setup Group 2	1 = Setup alarm has occurred
	1	CM-3	Cycle Modified Group 3	1 = Cycle modified alarm has occurred
	2	WA-4	Warning Group 4	1 = Warning alarm has occurred
	3	EQ-6	Equipment Failure Group 6	1 = Equipment failure alarm has occurred
	4	NC-7	No Cycle Group 7	1 = No cycle alarm has occurred
	5	CF-8	Communication Failure Group 8	1 = Communication alarm has occurred
	6	HW-A	Hardware Group A	1 = Hardware alarm has occurred
	7	CU-1	Cutoff Group 1	1 = Cutoff alarm has occurred
	8	TP-9	Future Use	Not used
	9	SM	Future Use	Not used
	10	OFF	Ultrasonics Off and DCX Ready	1 = Ultrasonics off and DCX ready
	11	ON	Ultrasonics Active	1 = Ultrasonics active
	12	OK	End of Weld Cycle Without Error	1 = End cycle without error
	13	LM-5	Limit Group 5	1 = Limit alarm has occurred
	14	MCLR	Memory Clear	1 = Memory offset will be set to 0
15	RES	Reserved	Not used	

## 8.5.3.3 Stack Function

**Table 8.12** Stack Function

Bit	Name	Test	Scan	Seek
STW2/1	SFCT	1	1	1
STW2/2	SFCT0	1	0	0
STW2/3	SFCT1	0	1	0
STW2/4	SFCT2	0	0	0

## 8.5.4 Implicit Message for Run

**Table 8.13** Implicit Message for Run

Value	STW1 Bit															
16384d	15	14	13	12	11	10	9	8	7	6	5	4	3	2	1	0
	0	1	0	0	0	0	0	0	0	0	0	0	0	0	0	0
Value	STW2 Bit															
513d	15	14	13	12	11	10	9	8	7	6	5	4	3	2	1	0
	0	0	0	0	0	0	1	0	0	0	0	0	0	0	0	1

## 8.5.5 Implicit Message for Seek

**Table 8.14** Implicit Message for Seek

Value	STW1 Bit															
16384d	15	14	13	12	11	10	9	8	7	6	5	4	3	2	1	0
	0	1	0	0	0	0	0	0	0	0	0	0	0	0	0	0
Value	STW2 Bit															
514d	15	14	13	12	11	10	9	8	7	6	5	4	3	2	1	0
	0	0	0	0	0	0	1	0	0	0	0	0	0	0	1	0

## 8.5.6 Implicit Message for Scan

**Table 8.15** Implicit Message for Scan

Value	STW1 Bit															
16384d	15	14	13	12	11	10	9	8	7	6	5	4	3	2	1	0
	0	1	0	0	0	0	0	0	0	0	0	0	0	0	0	0
Value	STW2 Bit															
522d	15	14	13	12	11	10	9	8	7	6	5	4	3	2	1	0
	0	0	0	0	0	0	1	0	0	0	0	0	1	0	1	0

## 8.5.7 Implicit Message for Reset

**Table 8.16** Implicit Message for Reset

Value	STW1 Bit															
16384d	15	14	13	12	11	10	9	8	7	6	5	4	3	2	1	0
	0	1	0	0	0	0	0	0	0	0	0	0	0	0	0	0
Value	STW2 Bit															
256d	15	14	13	12	11	10	9	8	7	6	5	4	3	2	1	0
	0	0	0	0	0	0	0	1	0	0	0	0	0	0	0	0

## 8.6 Explicit Messaging

NOTICE	
	See <a href="#">Appendix B: EtherNet/IP Commands</a> for a full listing of Explicit Messaging.

### 8.6.1 Establishing Token

In order to use Explicit Messaging, *Token* must be obtained. Token allows the PLC Explicit Communication between the PLC and DCX.

The following is an example for establishing Token using Explicit Messaging. The information is extracted from [B.8 Other Information Class 112 \(1 Instances\)](#).

Change values in Message Configuration for RSLogix 5000 Message Configuration to establish as follows:

**Table 8.17** Establishing Token

Name	Value
Class (Object)	112 (70 hex)
Attribute	50 (32 hex)
Instance	0 (DCX Preset Location 0)
Service Code/Type	Get = 14 (e hex)
Destination	Tag/register were the data is being sent

**Table 8.18** Attribute ID

Attribute ID	Description	Data Type	Access
50	Get Access Token	UINT8	Get
51	Put Access Token	UINT8	Get/Set

**Table 8.19** Common Services

Service Code	Service Name
14	Get_Attribute_Single
16	Set_Attribute_Single

### 8.6.1.1 RSLogix 5000 Implementation of Token

Getting Token must be established prior to the exchange of explicit messaging.

**Figure 8.3** RSLogix 5000 Implementation of Token

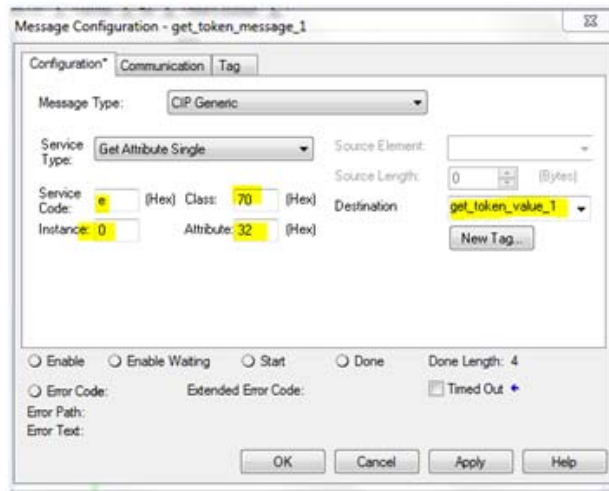

**Table 8.20** RSLogix 5000 Implementation of Token

Name	Value
Message Type	Select <i>CIP Generic</i> from the drop down menu.
Service Type	Select <i>Get Attribute Single</i> from the drop down menu.
Service Code	Value comes from the service type command.
Class	Object reference of DCX EtherNet/IP Commands. See <a href="#">Appendix B: EtherNet/IP Commands</a> .
Instance	Preset location. 32 locations (Token uses Location 0).
Attribute	Parameter reference (Attribute ID). See <a href="#">Appendix B: EtherNet/IP Commands</a> .
Destination	Tag/Register storage location in PLC for acquired DCX data.

### 8.6.1.2 Web Page Indication of Token Being Established

Confirmation of Token can be checked by accessing the DCX F EIP Web Page Interface.

The illumination of the radio button will turn red indicating Token (PLC control) has been obtained.

**Figure 8.4** Web Page Indication of Token Being Established

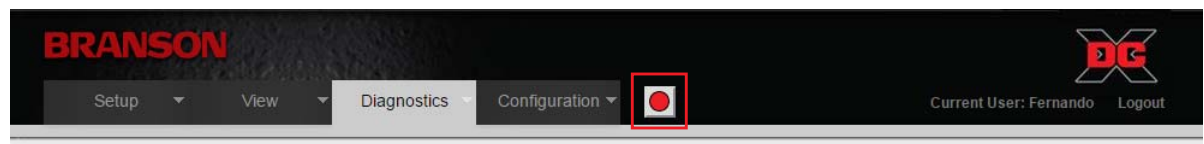

## 8.6.1.3 RSLogix 5000 Implementation of Token Release

**Figure 8.5** RSLogix 5000 Implementation of Token Release

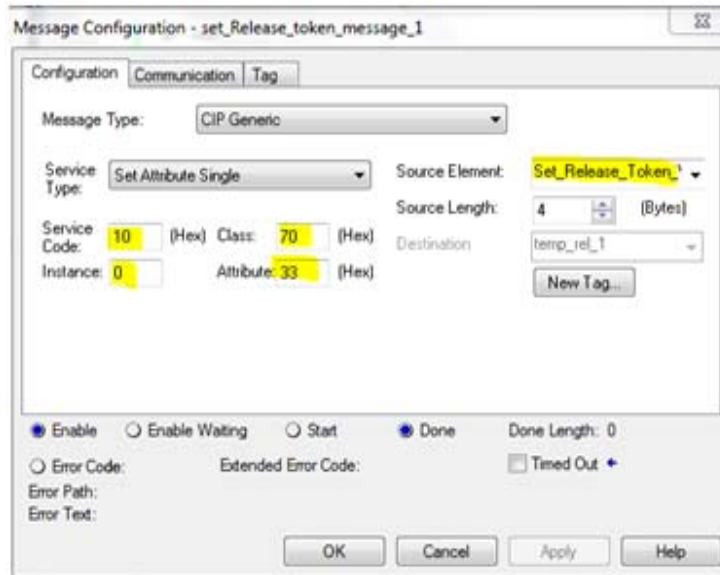

**Table 8.21** RSLogix 5000 Implementation of Token Release

Name	Value
Message Type	Select <i>CIP Generic</i> from the drop down menu.
Service Type	Select <i>Get Attribute Single</i> from the drop down menu.
Service Code	Value comes from the service type command.
Class	Object reference of DCX EtherNet/IP Commands. See <a href="#">Appendix B: EtherNet/IP Commands</a> .
Instance	Preset location. 32 locations (Token uses Location 0).
Attribute	Parameter reference (Attribute ID). See <a href="#">Appendix B: EtherNet/IP Commands</a> .
Source Element	Tag/Register storage location in PLC for acquired DCX data.

## 8.6.1.4 Web Page Indication of Token Being Released

Confirmation of Token can be checked by accessing the DCX F EIP Web Page Interface.

The illumination of the radio button will turn green indicating Token (PLC control) has been released.

**Figure 8.6** Web Page Indication of Token Being Released

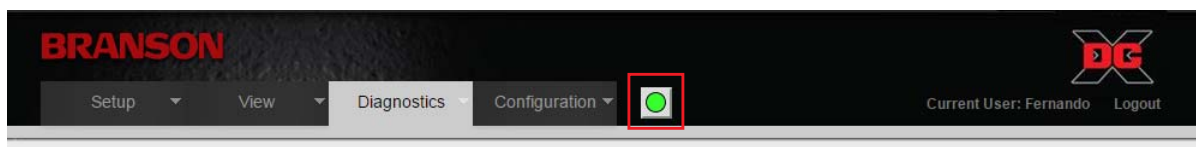



## 8.6.2 Obtaining (Get) Information from DCX

### 8.6.2.1 Get Energy Value Example

The following is an example for extracting Energy Value using Explicit Messaging. The information is extracted from [B.2 Weld Data Class 101 \(32 Instances\)](#).

Change values in Message Configuration for RSlogix5000 Message Configuration as follows:

**Table 8.22** Get Energy Value Example

Name	Value
Class (Object)	101 (65 hex)
Attribute	1362 (552 hex)
Instance	1 (DCX Preset Location 1)
Service Code/Type	Get = 14 (e hex)
Destination	Tag/Register were the data is being sent (energy value from last weld cycle)

**Table 8.23** Attribute ID

Attribute ID	Description	Data Type	Access
1362	Energy	UINT8	Get

**Table 8.24** Common Services

Service Code	Service Name
14	Get_Attribute_Single

## 8.6.2.2 RSLogix 5000 Implementation of Get Energy Value

**Figure 8.7** RSLogix 5000 Implementation of Get Energy Value

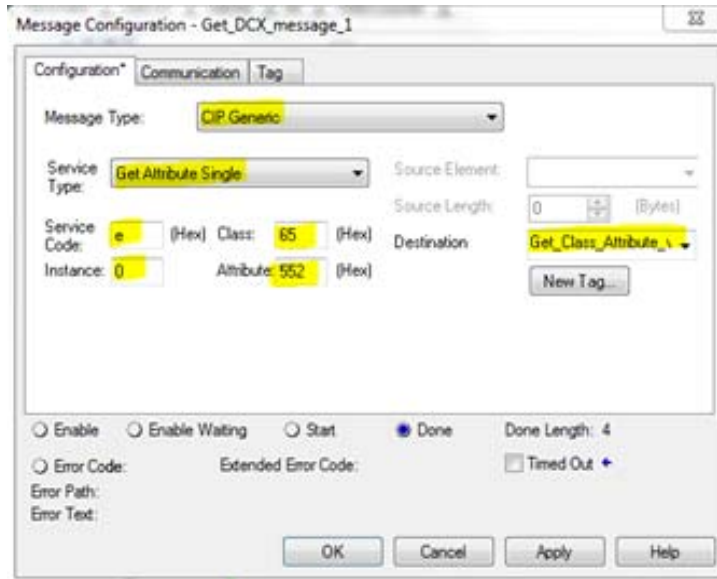

**Table 8.25** RSLogix 5000 Implementation of Get Energy Value

Name	Value
Message Type	Select <i>CIP Generic</i> from the drop down menu.
Service Type	Select <i>Get Attribute Single</i> from the drop down menu.
Service Code	Value comes from the service type command.
Class	Object reference of DCX EtherNet/IP Commands. See <a href="#">Appendix B: EtherNet/IP Commands</a> .
Instance	Preset location. 32 locations (location 0 is the active/running location).
Attribute	Parameter reference (Attribute ID). See <a href="#">Appendix B: EtherNet/IP Commands</a> .
Source Element	Tag/Register storage location in PLC for acquired DCX data.

## 8.6.3 Sending (Set) Parameter Values to DCX

### 8.6.3.1 Set Energy Value Example

The following is an example for sending the Energy Value using Explicit Messaging. The information is extracted from [B.1 Parameter Set Class 100 \(32 Instances\)](#).

Change values in Message Configuration for RSlogix5000 Message Configuration as follows:

**Table 8.26** Get Energy Value Example

Name	Value
Class (Object)	101 (66 hex)
Attribute	1062 (426 hex)
Instance	0 (DCX Preset Location 0)
Service Code/Type	Set = 16 (10 hex)
Destination	Tag/Register were the data is being sent (energy value to DCX)

**Table 8.27** Attribute ID

Attribute ID	Description	Data Type	Access
1062	Energy	AINT32	Get/Set

**Table 8.28** Common Services

Service Code	Service Name
16	Set_Attribute_Single

## 8.6.3.2 RSLogix 5000 Implementation of Set Energy Value

**Figure 8.8** RSLogix 5000 Implementation of Set Energy Value

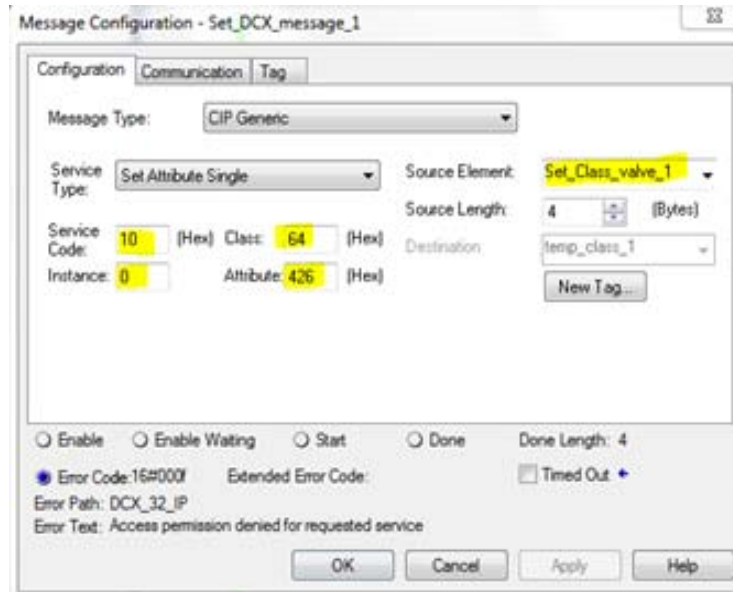

**Table 8.29** RSLogix 5000 Implementation of Set Energy Value

Name	Value
Message Type	Select <i>CIP Generic</i> from the drop down menu.
Service Type	Select <i>Set Attribute Single</i> from the drop down menu.
Service Code	Value comes from the service type command.
Class	Object reference of DCX EtherNet/IP Commands. See <a href="#">Appendix B: EtherNet/IP Commands</a> .
Instance	Preset location. 32 locations (location 0 is the active/running location).
Attribute	Parameter reference (Attribute ID). See <a href="#">Appendix B: EtherNet/IP Commands</a> .
Source Element	Tag/Register storage location in PLC for where DCX will be getting data from.

## 8.7 Implicit Messaging

### 8.7.1 Control/Status Word

The following examples will demonstrate the use of Implicit Messaging in performing a typical weld cycle. RSLogix 5000 Controller Tags will be used for this demonstration without need of a PLC program.

Refer to [8.4 Communication to the CompactLogix Via EtherNet/IP](#) for information on setting up the communication to the CompactLogix AB Controller via EtherNet/IP.

The DCX F-EIP is setup to operate in Time mode.

**Table 8.30** Control/Status Word (Time Mode)

Name	Value
Weld Time	5.0 s
Hold Time	10.0 s

The examples will concentrate on the Control (ZSW) and Status (STW) words, since these are the items that control and monitor the DCX cycling through the fieldbus.

[Table 8.31](#) is the information that the DCX will send to the PLC. This is the "Status" information from the DCX.

**Table 8.31** DCX Outputs/PLC Inputs (20 bytes)

Data	Description	Data Type	Access	Unit	Notes	
0	Reserved	UINT16	R			
1	Reserved					
2	ZSW1 (ZSW Word 1)			-	See <a href="#">Table 8.8</a> and <a href="#">Table 8.11</a>	
3	ZSW2 (ZSW Word 2)			-		
4	Nominal Amplitude Set			%		
5	Amplitude Output			%		
6	Current			%		
7	Power			%		
8	Phase			INT16	°	
9	PWM			UINT16	%	
10	Frequency				Hz	
11	Temperature	C				

[Table 8.32](#) is the information that the DCX will received from the PLC. This is the “Control” information to the DCX.

**Table 8.32** DCX Input

Data	Description	Data Type	Access	Unit	Notes
0	STW1 (STW Word 1)	UINT16	W	-	See <a href="#">Table 8.3</a> and <a href="#">Table 8.6</a>
1	SWT2 (STW Word 2)			-	
2	External Amplitude			%	
3	Frequency Offset			Hz	

## 8.7.2 DCX Initial State – No commands are being sent by PLC

PLC Output STW1/STW2 = 0

**Figure 8.9** PLC Output STW1/STW2 = 0

DCX_32_IP:0	{...}	{...}		AB:ETHERNET_...	
DCX_32_IP:0.Data	{...}	{...}	Decimal	INT[20]	
DCX_32_IP:0.Data[0]	0		Decimal	INT	stw1
DCX_32_IP:0.Data[1]	0		Decimal	INT	stw2
DCX_32_IP:0.Data[2]	0		Decimal	INT	ampl out
DCX_32_IP:0.Data[3]	0		Decimal	INT	freq offset

PLC Input ZSW1= 16, ZSW2=1024

Note that Live Channel information is also preset (Sonics Off condition shown).

**Figure 8.10** PLC Input ZSW1= 16, ZSW2=1024

DCX_32_IP:1	{...}	{...}		AB:ETHERNET_...	
DCX_32_IP:1.Data	{...}	{...}	Decimal	INT[20]	
DCX_32_IP:1.Data[0]	1		Decimal	INT	
DCX_32_IP:1.Data[1]	0		Decimal	INT	
DCX_32_IP:1.Data[2]	16		Decimal	INT	zsw1
DCX_32_IP:1.Data[3]	1024		Decimal	INT	zsw2
DCX_32_IP:1.Data[4]	74		Decimal	INT	set norm value
DCX_32_IP:1.Data[5]	0		Decimal	INT	ampl Out
DCX_32_IP:1.Data[6]	0		Decimal	INT	current
DCX_32_IP:1.Data[7]	0		Decimal	INT	power
DCX_32_IP:1.Data[8]	0		Decimal	INT	phase
DCX_32_IP:1.Data[9]	0		Decimal	INT	pwm
DCX_32_IP:1.Data[10]	30166		Decimal	INT	freq
DCX_32_IP:1.Data[11]	37		Decimal	INT	temp

### DCX Fieldbus Diagnostic

STW1/STW2 show no LEDs illuminated (PLC Output STW1/STW2 = 0)

ZSW1H/L: HFS0 bit 4 being illuminated (PLC Input ZSW1= 16 or 10000binary)

ZSW2H/L: HFS0 bit 11 being illuminated (PLC Input ZSW2= 1024 or 10000000000binary)

**Figure 8.11** DCX Fieldbus Diagnostic

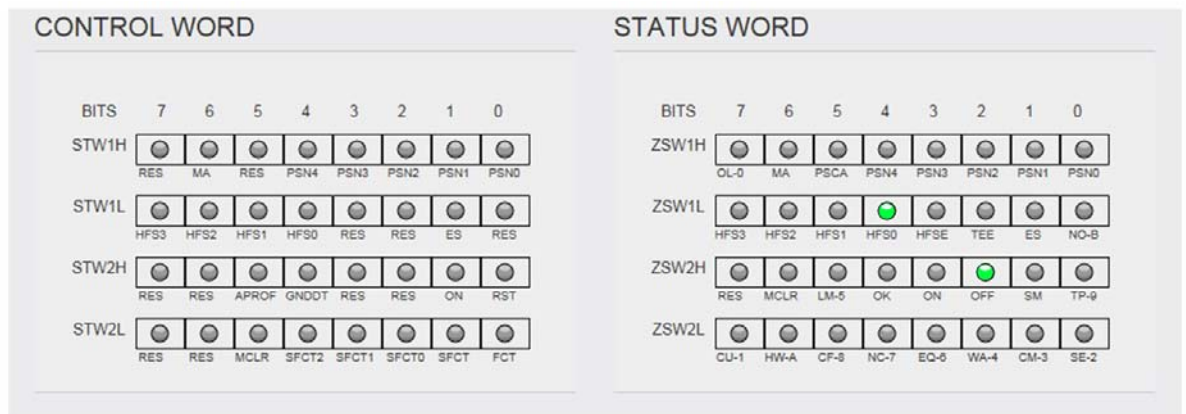

## 8.7.3 DCX Weld Mode - Sending a 513 command - Weld Time.

STW2 needs to stay in Auto mode (bit 14) -16384 command. Here we will pick the bits from STW2 that will start sonics.

To turn on sonics the Weld Function (FCT bit0) and Run Ultrasonics (ON, Bit 8) will be sent to the DCX thus creating a DCX Start Function. This will create the command 513 that will be sent to STW2.

**Figure 8.12** DCX Weld Mode - Sending a 513 Command - Weld Time

[-] DCX_32_IP.I.Data	{...}	{...}	Decimal	INT[20]	
+ DCX_32_IP.I.Data[0]	1		Decimal	INT	
+ DCX_32_IP.I.Data[1]	0		Decimal	INT	
+ DCX_32_IP.I.Data[2]	16400		Decimal	INT	zsw1
+ DCX_32_IP.I.Data[3]	2048		Decimal	INT	zsw2
+ DCX_32_IP.I.Data[4]	49		Decimal	INT	set norm value
+ DCX_32_IP.I.Data[5]	49		Decimal	INT	ampl Out
+ DCX_32_IP.I.Data[6]	29		Decimal	INT	current
+ DCX_32_IP.I.Data[7]	14		Decimal	INT	power
+ DCX_32_IP.I.Data[8]	0		Decimal	INT	phase
+ DCX_32_IP.I.Data[9]	24		Decimal	INT	pwm
+ DCX_32_IP.I.Data[10]	30195		Decimal	INT	freq
+ DCX_32_IP.I.Data[11]	32		Decimal	INT	temp
+ DCX_32_IP.I.Data[12]	0		Decimal	INT	
+ DCX_32_IP.I.Data[13]	0		Decimal	INT	
+ DCX_32_IP.I.Data[14]	0		Decimal	INT	
+ DCX_32_IP.I.Data[15]	0		Decimal	INT	
+ DCX_32_IP.I.Data[16]	0		Decimal	INT	
+ DCX_32_IP.I.Data[17]	0		Decimal	INT	
+ DCX_32_IP.I.Data[18]	0		Decimal	INT	
+ DCX_32_IP.I.Data[19]	0		Decimal	INT	
[-] DCX_32_IP.O	{...}	{...}		AB:ETHERNET_...	
[-] DCX_32_IP.O.Data	{...}	{...}	Decimal	INT[20]	
+ DCX_32_IP.O.Data[0]	16384		Decimal	INT	stw1
+ DCX_32_IP.O.Data[1]	513		Decimal	INT	stw2

### DCX Fieldbus Diagnostic

Note that the PLC Commands and responses will be mirrored in the DCX Control and Status Words.

**Figure 8.13** DCX Fieldbus Diagnostic Page

CONTROL WORD								STATUS WORD								
BITS 7 6 5 4 3 2 1 0								BITS 7 6 5 4 3 2 1 0								
STW1H	<input type="checkbox"/>	<input checked="" type="checkbox"/>	<input type="checkbox"/>	<input type="checkbox"/>	<input type="checkbox"/>	<input type="checkbox"/>	<input type="checkbox"/>	ZSW1H	<input type="checkbox"/>	<input checked="" type="checkbox"/>	<input type="checkbox"/>	<input type="checkbox"/>	<input type="checkbox"/>	<input type="checkbox"/>	<input type="checkbox"/>	
	RES	MA	RES	PSN4	PSN3	PSN2	PSN1	PSN0	OL-0	MA	PSCA	PSN4	PSN3	PSN2	PSN1	PSN0
STW1L	<input type="checkbox"/>	<input type="checkbox"/>	<input type="checkbox"/>	<input type="checkbox"/>	<input type="checkbox"/>	<input type="checkbox"/>	<input type="checkbox"/>	ZSW1L	<input type="checkbox"/>	<input type="checkbox"/>	<input checked="" type="checkbox"/>	<input type="checkbox"/>	<input type="checkbox"/>	<input type="checkbox"/>	<input type="checkbox"/>	<input type="checkbox"/>
	HFS3	HFS2	HFS1	HFS0	RES	RES	ES	RES	HFS3	HFS2	HFS1	HFS0	HFSE	TEE	ES	NO-B
STW2H	<input type="checkbox"/>	<input type="checkbox"/>	<input type="checkbox"/>	<input type="checkbox"/>	<input type="checkbox"/>	<input type="checkbox"/>	<input checked="" type="checkbox"/>	ZSW2H	<input type="checkbox"/>	<input type="checkbox"/>	<input checked="" type="checkbox"/>	<input type="checkbox"/>	<input type="checkbox"/>	<input type="checkbox"/>	<input type="checkbox"/>	<input type="checkbox"/>
	RES	RES	APROF	GNDOT	RES	RES	ON	RST	RES	MCLR	LM-5	OK	ON	OFF	SM	TP-9
STW2L	<input type="checkbox"/>	<input type="checkbox"/>	<input type="checkbox"/>	<input type="checkbox"/>	<input type="checkbox"/>	<input type="checkbox"/>	<input checked="" type="checkbox"/>	ZSW2L	<input type="checkbox"/>	<input type="checkbox"/>	<input type="checkbox"/>	<input type="checkbox"/>	<input type="checkbox"/>	<input type="checkbox"/>	<input type="checkbox"/>	<input type="checkbox"/>
	RES	RES	MCLR	SFCT2	SFCT1	SFCT0	SFCT	FCT	CU-1	HW-A	CF-B	NC-7	EQ-6	WA-4	CM-3	SE-2



## 8.7.4 DCX Weld Mode - Sending a 513 Command - Hold Time

No changes will be made to the STW1/STW2 from prior example. The MA and ON bit will continued to be sent to the DCX.

Here we will see the ZSW2 response has changed from Weld Time (sonics On) to Hold Time (sonics Off). Note that the ZSW2 has changes from 2048 to 0 indicating Sonics is OFF. This is the Hold Time State.

**Figure 8.14** DCX Weld Mode - Sending a 513 Command - Hold Time

[-] DCX_32_IP.I.Data	{...}	{...}	Decimal	INT[20]	
[+] DCX_32_IP.I.Data[0]	1		Decimal	INT	
[+] DCX_32_IP.I.Data[1]	0		Decimal	INT	
[+] DCX_32_IP.I.Data[2]	16400		Decimal	INT	zsw1
[+] DCX_32_IP.I.Data[3]	0		Decimal	INT	zsw2
[+] DCX_32_IP.I.Data[4]	49		Decimal	INT	set norm value
[+] DCX_32_IP.I.Data[5]	0		Decimal	INT	ampl Out
[+] DCX_32_IP.I.Data[6]	0		Decimal	INT	current
[+] DCX_32_IP.I.Data[7]	0		Decimal	INT	power
[+] DCX_32_IP.I.Data[8]	0		Decimal	INT	phase
[+] DCX_32_IP.I.Data[9]	0		Decimal	INT	pwm
[+] DCX_32_IP.I.Data[10]	30195		Decimal	INT	freq
[+] DCX_32_IP.I.Data[11]	32		Decimal	INT	temp
[+] DCX_32_IP.I.Data[12]	0		Decimal	INT	
[+] DCX_32_IP.I.Data[13]	0		Decimal	INT	
[+] DCX_32_IP.I.Data[14]	0		Decimal	INT	
[+] DCX_32_IP.I.Data[15]	0		Decimal	INT	
[+] DCX_32_IP.I.Data[16]	0		Decimal	INT	
[+] DCX_32_IP.I.Data[17]	0		Decimal	INT	
[+] DCX_32_IP.I.Data[18]	0		Decimal	INT	
[+] DCX_32_IP.I.Data[19]	0		Decimal	INT	
[-] DCX_32_IP.0	{...}	{...}		AB:ETHERNET_...	
[-] DCX_32_IP.0.Data	{...}	{...}	Decimal	INT[20]	
[+] DCX_32_IP.0.Data[0]	16384		Decimal	INT	stw1
[+] DCX_32_IP.0.Data[1]	513		Decimal	INT	stw2

### DCX Fieldbus Diagnostic

Note that the ZSW2 ON bit 11 is now Off also indicating Sonics is OFF. This is the Hold Time State.

**Figure 8.15** DCX Fieldbus Diagnostic

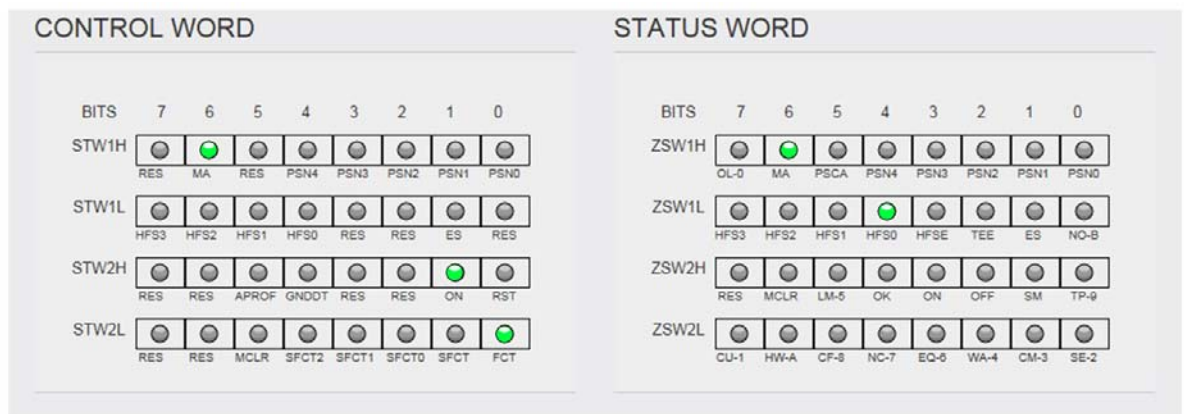

## 8.7.5 DCX Weld Mode - Sending a 0 command - Changeover State

STW1 needs to stay in Auto mode (bit 14) -16384 command. STW2 from prior example. The MA and ON bit will continued to be sent to the DCX. A command 0 will be sent to STW2 to release the FCT (bit0) and On (bit 8) thus removing the DCX Start Function.

Here we will see the ZSW2 response has changed from Hold Time to End of Weld Cycle. Note that the ZSW2 has changes from 0 to 5120 indicating Weld Cycle is complete.

**Figure 8.16** DCX Weld Mode - Sending a 0 Command - Changeover State

[-] DCX_32_IP.I.Data	{...}	{...}	Decimal	INT[20]	
+ DCX_32_IP.I.Data[0]	1		Decimal	INT	
+ DCX_32_IP.I.Data[1]	0		Decimal	INT	
+ DCX_32_IP.I.Data[2]	16400		Decimal	INT	zsw1
+ DCX_32_IP.I.Data[3]	5120		Decimal	INT	zsw2
+ DCX_32_IP.I.Data[4]	49		Decimal	INT	set norm value
+ DCX_32_IP.I.Data[5]	0		Decimal	INT	ampl Out
+ DCX_32_IP.I.Data[6]	0		Decimal	INT	current
+ DCX_32_IP.I.Data[7]	0		Decimal	INT	power
+ DCX_32_IP.I.Data[8]	0		Decimal	INT	phase
+ DCX_32_IP.I.Data[9]	0		Decimal	INT	pwm
+ DCX_32_IP.I.Data[10]	30194		Decimal	INT	freq
+ DCX_32_IP.I.Data[11]	33		Decimal	INT	temp
+ DCX_32_IP.I.Data[12]	0		Decimal	INT	
+ DCX_32_IP.I.Data[13]	0		Decimal	INT	
+ DCX_32_IP.I.Data[14]	0		Decimal	INT	
+ DCX_32_IP.I.Data[15]	0		Decimal	INT	
+ DCX_32_IP.I.Data[16]	0		Decimal	INT	
+ DCX_32_IP.I.Data[17]	0		Decimal	INT	
+ DCX_32_IP.I.Data[18]	0		Decimal	INT	
+ DCX_32_IP.I.Data[19]	0		Decimal	INT	
[-] DCX_32_IP.O	{...}	{...}		AB:ETHERNET_...	
[-] DCX_32_IP.O.Data	{...}	{...}	Decimal	INT[20]	
+ DCX_32_IP.O.Data[0]	16384		Decimal	INT	stw1
+ DCX_32_IP.O.Data[1]	0		Decimal	INT	stw2

### DCX Fieldbus Diagnostic

Note that none of the STW2 bits are active, thus mirroring the STW2 "0" command sent by the PLC. The ZSW2 shows End of Weld Cycle (Bit 12) and Ultrasonics OFF (bit 10) illuminated indicating Weld cycle is complete.

**Figure 8.17** DCX Fieldbus Diagnostic Page

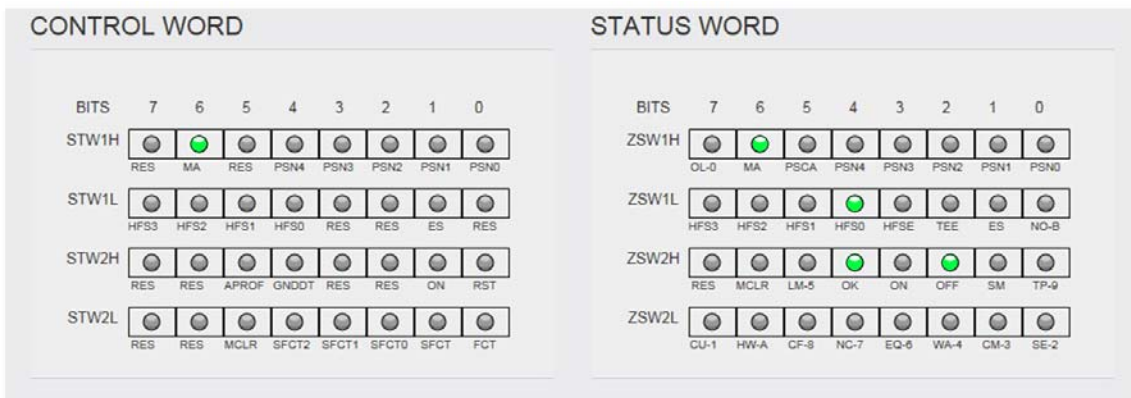

## 8.7.6

### DCX Weld Mode - Sending a 513 and Holding it to Create a "Start Input is Active" Alarm

A command 513 will be sent and held constant to STW2 FCT (bit0) and On (bit 8) to invoke a DCX Start Function. (Refer to Weld Time Example). At some point after the Weld Cycle is complete a "Start Input is Active" alarm will be generated at the DCX. Note that the ZSW2 is 4104 indicating a Equipment failure has occurred.

**Figure 8.18** DCX Weld Mode - Sending a 513 and Holding It to Create a "Start Input is Active" Alarm

[-] DCX_32_IP.I.Data	{ ... }	{ ... }	Decimal	INT[20]	
[+] DCX_32_IP.I.Data[0]	1		Decimal	INT	
[+] DCX_32_IP.I.Data[1]	0		Decimal	INT	
[+] DCX_32_IP.I.Data[2]	16400		Decimal	INT	zsw1
[+] DCX_32_IP.I.Data[3]	4104		Decimal	INT	zsw2
[+] DCX_32_IP.I.Data[4]	49		Decimal	INT	set norm value
[+] DCX_32_IP.I.Data[5]	0		Decimal	INT	ampl Out
[+] DCX_32_IP.I.Data[6]	0		Decimal	INT	current
[+] DCX_32_IP.I.Data[7]	0		Decimal	INT	power
[+] DCX_32_IP.I.Data[8]	0		Decimal	INT	phase
[+] DCX_32_IP.I.Data[9]	0		Decimal	INT	pwm
[+] DCX_32_IP.I.Data[10]	30195		Decimal	INT	freq
[+] DCX_32_IP.I.Data[11]	33		Decimal	INT	temp
[+] DCX_32_IP.I.Data[12]	0		Decimal	INT	
[+] DCX_32_IP.I.Data[13]	0		Decimal	INT	
[+] DCX_32_IP.I.Data[14]	0		Decimal	INT	
[+] DCX_32_IP.I.Data[15]	0		Decimal	INT	
[+] DCX_32_IP.I.Data[16]	0		Decimal	INT	
[+] DCX_32_IP.I.Data[17]	0		Decimal	INT	
[+] DCX_32_IP.I.Data[18]	0		Decimal	INT	
[+] DCX_32_IP.I.Data[19]	0		Decimal	INT	
[-] DCX_32_IP.O	{ ... }	{ ... }		AB:ETHERNET_...	
[-] DCX_32_IP.O.Data	{ ... }	{ ... }	Decimal	INT[20]	
[+] DCX_32_IP.O.Data[0]	16384		Decimal	INT	stw1
[+] DCX_32_IP.O.Data[1]	513		Decimal	INT	stw2

### DCX Fieldbus Diagnostic

Note that STW2 Shows ON and FCT still being active (the 513 command). The ZSW2 show the OK and EQ8 LEDs being active.

**Figure 8.19** DCX Fieldbus Diagnostics

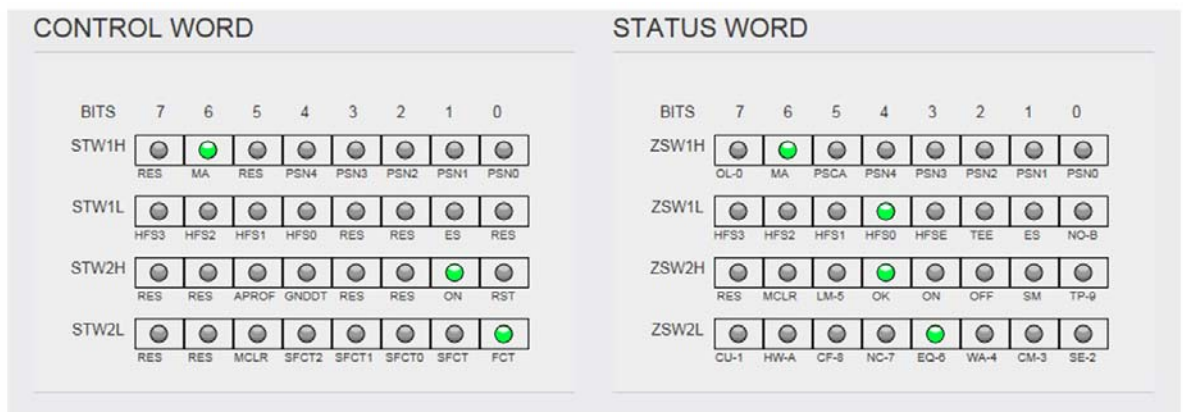

## 8.7.7 DCX Weld Mode - Alarm Reset

Using the prior “Start Input is Active” alarm example, we will send a Reset command to clear the alarm condition.

For this to occur the 513 command (DCX Start Function) will be removed first. We will send a command 0 to release the DCX Start function. Then we will send a command 256 to Reset the DCX alarm. Once the Alarm is Reset a 0 command will be sent to release the Reset command. Note that the ZSW2 is 5128 indicating a Equipment failure has occurred.

**Figure 8.20** DCX Weld Mode - Alarm Reset

[-] DCX_32_IP:I.Data	{...}	{...}	Decimal	INT[20]	
+ DCX_32_IP:I.Data[0]	1		Decimal	INT	
+ DCX_32_IP:I.Data[1]	0		Decimal	INT	
+ DCX_32_IP:I.Data[2]	16400		Decimal	INT	zsw1
+ DCX_32_IP:I.Data[3]	5128		Decimal	INT	zsw2
+ DCX_32_IP:I.Data[4]	49		Decimal	INT	set norm value
+ DCX_32_IP:I.Data[5]	0		Decimal	INT	ampl Out
+ DCX_32_IP:I.Data[6]	0		Decimal	INT	current
+ DCX_32_IP:I.Data[7]	0		Decimal	INT	power
+ DCX_32_IP:I.Data[8]	0		Decimal	INT	phase
+ DCX_32_IP:I.Data[9]	0		Decimal	INT	pwm
+ DCX_32_IP:I.Data[10]	30195		Decimal	INT	freq
+ DCX_32_IP:I.Data[11]	32		Decimal	INT	temp
+ DCX_32_IP:I.Data[12]	0		Decimal	INT	
+ DCX_32_IP:I.Data[13]	0		Decimal	INT	
+ DCX_32_IP:I.Data[14]	0		Decimal	INT	
+ DCX_32_IP:I.Data[15]	0		Decimal	INT	
+ DCX_32_IP:I.Data[16]	0		Decimal	INT	
+ DCX_32_IP:I.Data[17]	0		Decimal	INT	
+ DCX_32_IP:I.Data[18]	0		Decimal	INT	
+ DCX_32_IP:I.Data[19]	0		Decimal	INT	
[-] DCX_32_IP:O	{...}	{...}		AB:ETHERNET_...	
[-] DCX_32_IP:O.Data	{...}	{...}	Decimal	INT[20]	
+ DCX_32_IP:O.Data[0]	16384		Decimal	INT	stw1
+ DCX_32_IP:O.Data[1]	0		Decimal	INT	stw2

### DCX Fieldbus Diagnostic

Note that STW2 Shows ON and FCT are now OFF (the 0 command). The ZSW2 show the OFF and EQ8 LEDs being active.

## 8.7.7.1 DCX Weld Mode - Alarm Reset (Cont)

STW2 shows the 256 Command being sent to Reset the DCX alarm. ZSW2 response 1024 indicates that Alarm is Reset and the DCX is in the Ready state.

**Figure 8.21** DCX Weld Mode - Alarm Reset (Cont)

[-] DCX_32_IP.I.Data	{...}	{...}	Decimal	INT[20]	
[+] DCX_32_IP.I.Data[0]	1		Decimal	INT	
[+] DCX_32_IP.I.Data[1]	0		Decimal	INT	
[+] DCX_32_IP.I.Data[2]	16400		Decimal	INT	zsw1
[+] DCX_32_IP.I.Data[3]	1024		Decimal	INT	zsw2
[+] DCX_32_IP.I.Data[4]	49		Decimal	INT	set norm value
[+] DCX_32_IP.I.Data[5]	0		Decimal	INT	ampl Out
[+] DCX_32_IP.I.Data[6]	0		Decimal	INT	current
[+] DCX_32_IP.I.Data[7]	0		Decimal	INT	power
[+] DCX_32_IP.I.Data[8]	0		Decimal	INT	phase
[+] DCX_32_IP.I.Data[9]	0		Decimal	INT	pwm
[+] DCX_32_IP.I.Data[10]	30195		Decimal	INT	freq
[+] DCX_32_IP.I.Data[11]	32		Decimal	INT	temp
[+] DCX_32_IP.I.Data[12]	0		Decimal	INT	
[+] DCX_32_IP.I.Data[13]	0		Decimal	INT	
[+] DCX_32_IP.I.Data[14]	0		Decimal	INT	
[+] DCX_32_IP.I.Data[15]	0		Decimal	INT	
[+] DCX_32_IP.I.Data[16]	0		Decimal	INT	
[+] DCX_32_IP.I.Data[17]	0		Decimal	INT	
[+] DCX_32_IP.I.Data[18]	0		Decimal	INT	
[+] DCX_32_IP.I.Data[19]	0		Decimal	INT	
[-] DCX_32_IP.O	{...}	{...}		AB:ETHERNET_...	
[-] DCX_32_IP.O.Data	{...}	{...}	Decimal	INT[20]	
[+] DCX_32_IP.O.Data[0]	16384		Decimal	INT	stw1
[+] DCX_32_IP.O.Data[1]	256		Decimal	INT	stw2

## DCX Fieldbus Diagnostic

The ZSW2 show the OFF LED being active. The DCX is in the Ready State.

**Figure 8.22** DCX Fieldbus Diagnostic

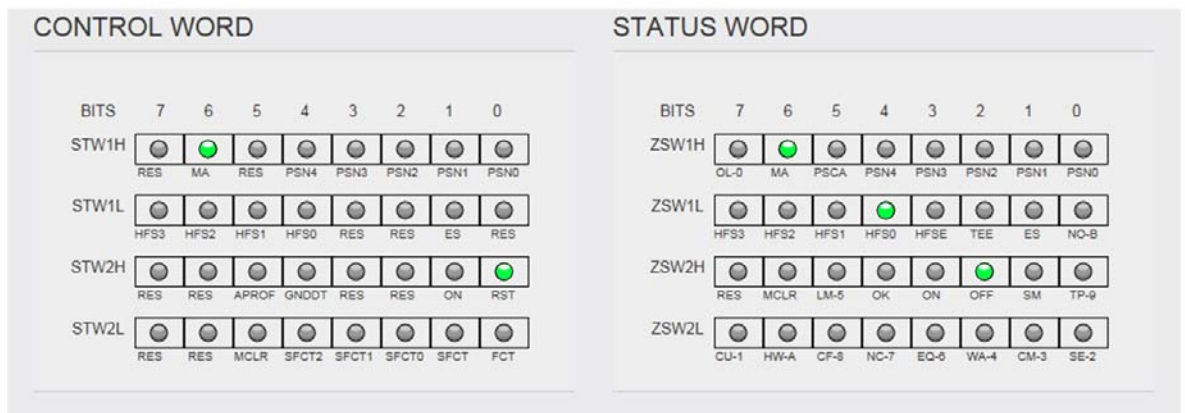

## 8.7.7.2 DCX Weld Mode - Alarm Reset (Cont)

STW2 shows the 0 Command being sent to release the Reset command to the DCX. ZSW2 response 1024 indicates that DCX is in the Ready state.

**Figure 8.23** DCX Weld Mode - Alarm Reset (Cont)

[-] DCX_32_IP:I.Data	{...}	{...}	Decimal	INT[20]	
+ DCX_32_IP:I.Data[0]	1		Decimal	INT	
+ DCX_32_IP:I.Data[1]	0		Decimal	INT	
+ DCX_32_IP:I.Data[2]	16400		Decimal	INT	zsw1
+ DCX_32_IP:I.Data[3]	1024		Decimal	INT	zsw2
+ DCX_32_IP:I.Data[4]	49		Decimal	INT	set norm value
+ DCX_32_IP:I.Data[5]	0		Decimal	INT	ampl Out
+ DCX_32_IP:I.Data[6]	0		Decimal	INT	current
+ DCX_32_IP:I.Data[7]	0		Decimal	INT	power
+ DCX_32_IP:I.Data[8]	0		Decimal	INT	phase
+ DCX_32_IP:I.Data[9]	0		Decimal	INT	pwm
+ DCX_32_IP:I.Data[10]	30195		Decimal	INT	freq
+ DCX_32_IP:I.Data[11]	32		Decimal	INT	temp
+ DCX_32_IP:I.Data[12]	0		Decimal	INT	
+ DCX_32_IP:I.Data[13]	0		Decimal	INT	
+ DCX_32_IP:I.Data[14]	0		Decimal	INT	
+ DCX_32_IP:I.Data[15]	0		Decimal	INT	
+ DCX_32_IP:I.Data[16]	0		Decimal	INT	
+ DCX_32_IP:I.Data[17]	0		Decimal	INT	
+ DCX_32_IP:I.Data[18]	0		Decimal	INT	
+ DCX_32_IP:I.Data[19]	0		Decimal	INT	
[-] DCX_32_IP:O	{...}	{...}		AB:ETHERNET_...	
[-] DCX_32_IP:O.Data	{...}	{...}	Decimal	INT[20]	
+ DCX_32_IP:O.Data[0]	16384		Decimal	INT	stw1
+ DCX_32_IP:O.Data[1]	0		Decimal	INT	stw2

## DCX Fieldbus Diagnostic

STW2 shows no bits are active indicating that no commands (or command 0) is being sent by the PLC to the DCX. ZSW2 show the OFF LED being active. The DCX is in the Ready State and awaiting next Weld Cycle command.

**Figure 8.24** DCX Fieldbus Diagnostic

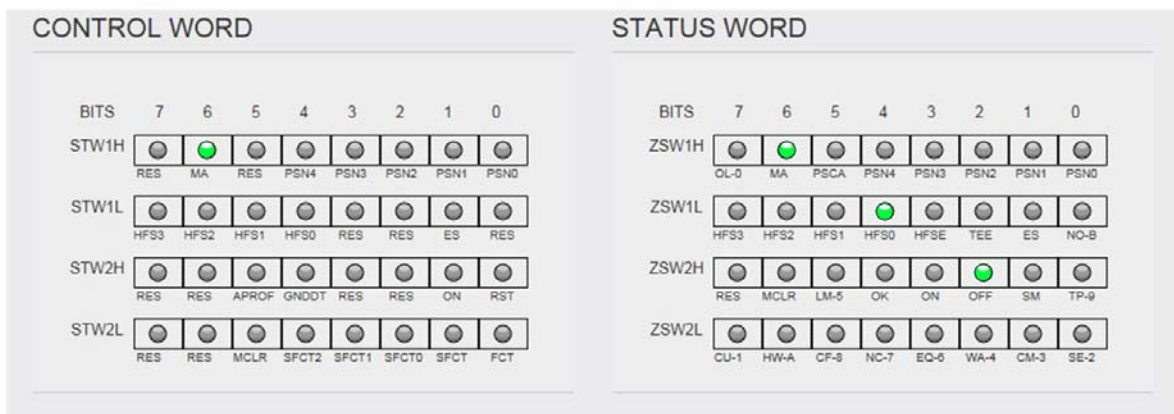

## 8.8 Implicit Messaging Live Channel

[Table 8.7 DCX Outputs/PLC Inputs \(20 bytes\)](#) is the information that the DCX will send to the PLC. This is the *Status* information from the DCX.

[Table 8.2 DCX Inputs/PLC Outputs \(8 bytes\)](#) is the information that the DCX will receive from the PLC. This is the *Control* information to the DCX.

During PLC setup/configuration, RSLogix 5000 is setup to reserve 20 locations of Input and Output (Connection Parameters) for Implicit Messaging.

**Figure 8.25** Implicit Messaging

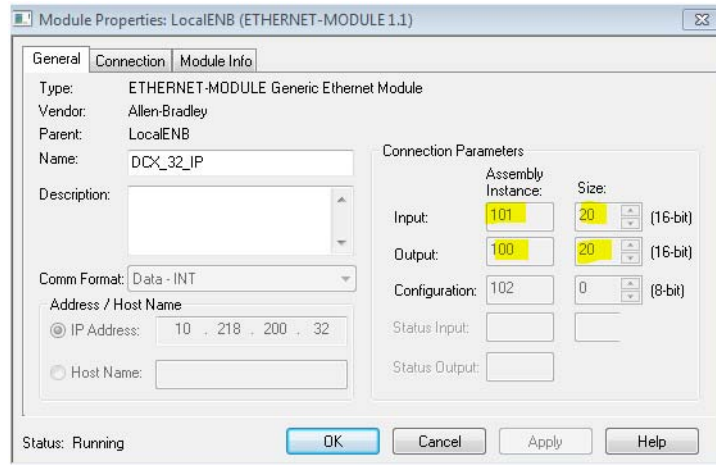

This Live Channel information can be viewed by opening the Controller Tag (RSLogix 5000) for each of the DCX devices.

Below is the PLC Output Data - Data going to the DCX (Control).

**Figure 8.26** Data Going to the DCX (Control)

DCX_32_IP:0	{...}	{...}	AB:ETHERNET_...
DCX_32_IP:0.Data	{...}	{...}	Decimal INT[20]
+ DCX_32_IP:0.Data[0]	16384		Decimal INT stw1
+ DCX_32_IP:0.Data[1]	513		Decimal INT stw2
+ DCX_32_IP:0.Data[2]	75		Decimal INT ampl out
+ DCX_32_IP:0.Data[3]	3		Decimal INT freq offset
+ DCX_32_IP:0.Data[4]	0		Decimal INT
+ DCX_32_IP:0.Data[5]	0		Decimal INT
+ DCX_32_IP:0.Data[6]	0		Decimal INT
+ DCX_32_IP:0.Data[7]	0		Decimal INT
+ DCX_32_IP:0.Data[8]	0		Decimal INT
+ DCX_32_IP:0.Data[9]	0		Decimal INT
+ DCX_32_IP:0.Data[10]	0		Decimal INT
+ DCX_32_IP:0.Data[11]	0		Decimal INT
+ DCX_32_IP:0.Data[12]	0		Decimal INT
+ DCX_32_IP:0.Data[13]	0		Decimal INT
+ DCX_32_IP:0.Data[14]	0		Decimal INT
+ DCX_32_IP:0.Data[15]	0		Decimal INT
+ DCX_32_IP:0.Data[16]	0		Decimal INT
+ DCX_32_IP:0.Data[17]	0		Decimal INT
+ DCX_32_IP:0.Data[18]	0		Decimal INT
+ DCX_32_IP:0.Data[19]	0		Decimal INT

Below is the PLC Input Data - Data coming from the DCX (Status).

**Figure 8.27** Data Coming from the DCX (Status)

Name	Value	Force Mask	Style	Data Type	Description
+ DCX_32_IP:C	{...}	{...}		AB:ETHERNET_...	
- DCX_32_IP:I	{...}	{...}		AB:ETHERNET_...	
- DCX_32_IP:I.Data	{...}	{...}	Decimal	INT[20]	
+ DCX_32_IP:I.Data[0]	1		Decimal	INT	
+ DCX_32_IP:I.Data[1]	0		Decimal	INT	
+ DCX_32_IP:I.Data[2]	16400		Decimal	INT	zsw1
+ DCX_32_IP:I.Data[3]	2048		Decimal	INT	zsw2
+ DCX_32_IP:I.Data[4]	74		Decimal	INT	set norm value
+ DCX_32_IP:I.Data[5]	75		Decimal	INT	ampl Out
+ DCX_32_IP:I.Data[6]	44		Decimal	INT	current
+ DCX_32_IP:I.Data[7]	34		Decimal	INT	power
+ DCX_32_IP:I.Data[8]	0		Decimal	INT	phase
+ DCX_32_IP:I.Data[9]	36		Decimal	INT	pwm
+ DCX_32_IP:I.Data[10]	30164		Decimal	INT	freq
+ DCX_32_IP:I.Data[11]	36		Decimal	INT	temp
+ DCX_32_IP:I.Data[12]	0		Decimal	INT	
+ DCX_32_IP:I.Data[13]	0		Decimal	INT	
+ DCX_32_IP:I.Data[14]	0		Decimal	INT	
+ DCX_32_IP:I.Data[15]	0		Decimal	INT	
+ DCX_32_IP:I.Data[16]	0		Decimal	INT	
+ DCX_32_IP:I.Data[17]	0		Decimal	INT	
+ DCX_32_IP:I.Data[18]	0		Decimal	INT	
+ DCX_32_IP:I.Data[19]	0		Decimal	INT	

The word fields for STW1/STW2 (Control Word) and ZSW1/ZSW2 (Status Word) can be expanded to view these words at the binary bit level.



## 8.8.1 Live PLC Input Channel Example (DCX Status Word)

The following example shows the PLC input channel expanded to bit level. The ZSW1 word 16400 is displayed at its binary level. Bit 4 (HFS0), and Bit 14 (MA) = 1 are shown as being active on the Diagnostics Fieldbus section on the DCX Web Page Interface.

Figure 8.28 DCX Status Word

[-] DCX_32_IP.I.Data	[...]	[...]	Decimal	INT[20]	
+ DCX_32_IP.I.Data[0]	1		Decimal	INT	
+ DCX_32_IP.I.Data[1]	0		Decimal	INT	
[-] DCX_32_IP.I.Data[2]	16400		Decimal	INT	zsw1
- DCX_32_IP.I.Data[2] 0	0		Decimal	BOOL	zsw1
- DCX_32_IP.I.Data[2] 1	0		Decimal	BOOL	zsw1
- DCX_32_IP.I.Data[2] 2	0		Decimal	BOOL	zsw1
- DCX_32_IP.I.Data[2] 3	0		Decimal	BOOL	zsw1
- DCX_32_IP.I.Data[2] 4	1		Decimal	BOOL	zsw1
- DCX_32_IP.I.Data[2] 5	0		Decimal	BOOL	zsw1
- DCX_32_IP.I.Data[2] 6	0		Decimal	BOOL	zsw1
- DCX_32_IP.I.Data[2] 7	0		Decimal	BOOL	zsw1
- DCX_32_IP.I.Data[2] 8	0		Decimal	BOOL	zsw1
- DCX_32_IP.I.Data[2] 9	0		Decimal	BOOL	zsw1
- DCX_32_IP.I.Data[2] 10	0		Decimal	BOOL	zsw1
- DCX_32_IP.I.Data[2] 11	0		Decimal	BOOL	zsw1
- DCX_32_IP.I.Data[2] 12	0		Decimal	BOOL	zsw1
- DCX_32_IP.I.Data[2] 13	0		Decimal	BOOL	zsw1
- DCX_32_IP.I.Data[2] 14	1		Decimal	BOOL	zsw1
- DCX_32_IP.I.Data[2] 15	0		Decimal	BOOL	zsw1

Figure 8.29 Status Word (Web Page Interface)

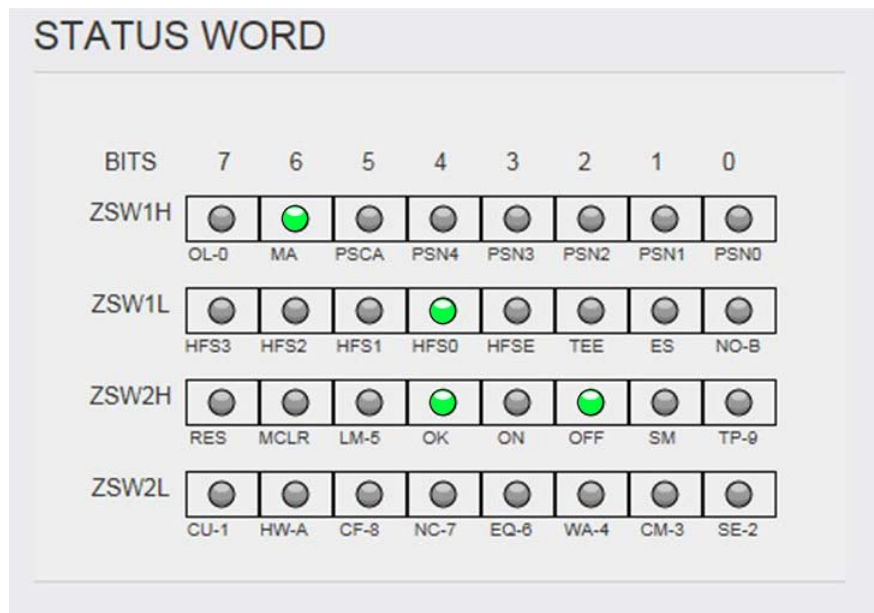

## 8.8.2 Live PLC Output Channel Example (DCX Control Word)

The following shows the PLC output channel expanded to bit level. The STW1 word “16384” is displayed at its binary level. Bit 14 (MA) = 1 and is shown as being active on the Diagnostics Fieldbus section on the DCX Web Page Interface.

Figure 8.30 DCX Control Word

DCX_32_IP:0	{...}	{...}		AB:ETHERNET_...	
DCX_32_IP:0.Data	{...}	{...}	Decimal	INT[20]	
DCX_32_IP:0.Data[0]	16384		Decimal	INT	stw1
DCX_32_IP:0.Data[0].0	0		Decimal	BOOL	stw1
DCX_32_IP:0.Data[0].1	0		Decimal	BOOL	stw1
DCX_32_IP:0.Data[0].2	0		Decimal	BOOL	stw1
DCX_32_IP:0.Data[0].3	0		Decimal	BOOL	stw1
DCX_32_IP:0.Data[0].4	0		Decimal	BOOL	stw1
DCX_32_IP:0.Data[0].5	0		Decimal	BOOL	stw1
DCX_32_IP:0.Data[0].6	0		Decimal	BOOL	stw1
DCX_32_IP:0.Data[0].7	0		Decimal	BOOL	stw1
DCX_32_IP:0.Data[0].8	0		Decimal	BOOL	stw1
DCX_32_IP:0.Data[0].9	0		Decimal	BOOL	stw1
DCX_32_IP:0.Data[0].10	0		Decimal	BOOL	stw1
DCX_32_IP:0.Data[0].11	0		Decimal	BOOL	stw1
DCX_32_IP:0.Data[0].12	0		Decimal	BOOL	stw1
DCX_32_IP:0.Data[0].13	0		Decimal	BOOL	stw1
DCX_32_IP:0.Data[0].14	1		Decimal	BOOL	stw1
DCX_32_IP:0.Data[0].15	0		Decimal	BOOL	stw1

Figure 8.31 DCX Control Word (Web Page Interface)

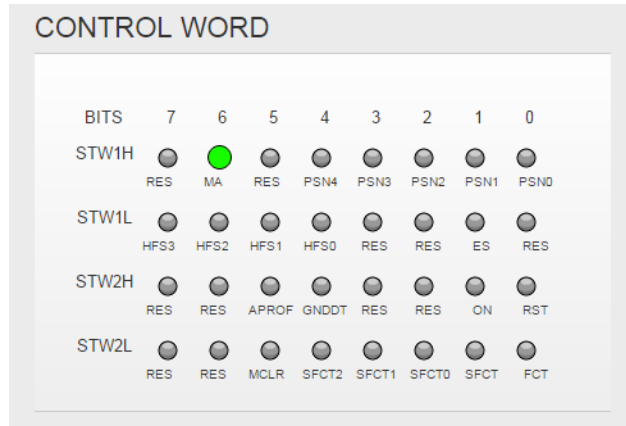

---

## Chapter 9: Maintenance

---

9.1	General Maintenance Considerations . . . . .	168
9.2	DCX F-EIP Power Supply Preventive Maintenance . . . . .	170
9.3	Recommended Spare Stock . . . . .	176
9.4	Circuit Diagram . . . . .	182
9.5	Troubleshooting . . . . .	183
9.6	Cold Start Procedure . . . . .	187

## 9.1 General Maintenance Considerations

WARNING	High Voltage Hazard
	<p>Power supplies produce high voltage. To avoid the possibility of an electrical shock, you should always power down your system prior to repairing any portion of it.</p>

CAUTION	General Warning
	<p>When performing maintenance on the welder, make sure that no other automated systems are active.</p>

NOTICE	
	<p>There are no customer replaceable components inside the power supply. Have all servicing done by a qualified Branson technician.</p>

NOTICE	
	<p>When returning printed circuit boards, make sure to enclose them in an anti-static package.</p>

NOTICE	
	<p>Connectors may not be keyed and wires may not be color-coded. Therefore, when disconnecting cables and wires, label them so you can reconnect them properly.</p>

NOTICE	
	To prevent circuit damage from electrostatic discharge, always service the power supply on a static-dissipative surface, while wearing a properly grounded wrist strap.

NOTICE	
	When the battery is worn out, dispose it under the ordinance of each local government.

## 9.2 DCX F-EIP Power Supply Preventive Maintenance

The following preventive measures help assure long term operation of your Branson DCX F-EIP Power Supply equipment.

### 9.2.1 Periodically Clean the Equipment

NOTICE	
	Use only anti-static vacuum cleaners to prevent damage from electrostatic discharge to your power supply.

Air is continuously drawn into the power supply. Periodically disconnect the unit from power, remove the cover and vacuum out any accumulated dust and debris. Remove material adhering to:

- The fan blades and motor
- Power supply heat sink cooling fins
- Transformers
- Circuit boards
- Cooling intake vents
- Exhaust ports

External covers may be cleaned with a damp sponge or cloth using a solution of mild soap and water. Do not allow cleaning solution to enter the unit.

To prevent rust in areas of high humidity, exposed steel surfaces, may require a very light film of rust preventing oil, such as WD-40®\*.

\* WD-40 is a registered trademark of WD-40 Manufacturing Company.

## 9.2.2 Recondition the Stack (Converter, Booster, and Horn)

NOTICE	
	Never clean the converter-booster-horn stack mating surfaces by using a buffing wheel or by filing.

Welding system components work most efficiently when the converter-booster-horn stack mating surfaces are flat, in solid contact, and free from fretting corrosion. Poor contact between mating surfaces wastes power output, makes tuning difficult, increases noise and heat, and may cause damage to the converter.

For standard 20 kHz and 30 kHz products, a Branson Mylar polyester film washer should be installed between the horn and booster, and horn and converter. Replace the washer if torn or perforated. Stacks using Mylar plastic film washers should be inspected every three months.

Stacks used with silicone grease, as with certain 20 kHz, 30 kHz and all 40 kHz products, should be periodically reconditioned to eliminate fretting corrosion. A stack using silicone grease should be inspected every two weeks for corrosion. When experience is gained for specific stacks, the inspection interval can be adjusted to a longer or shorter period as required.

## Stack Reconditioning Procedure

To recondition stack mating surfaces, take the following steps:

**Table 9.1** Stack Reconditioning Procedure

Step	Action
1	Disassemble the converter-booster-horn stack and wipe the mating surfaces with a clean cloth or paper towel.
2	Examine all mating surfaces. If any mating surface shows corrosion or a hard, dark deposit, recondition it.
3	If necessary, remove the threaded stud from the part.
4	Tape a clean sheet of #400 (or finer) grit emery cloth to a clean, smooth, flat surface (such as a sheet of plate glass), as in <a href="#">Figure 9.1 Reconditioning Stack Mating Surfaces</a> .
5	Place the interface surface on the emery cloth. Grasp the part at the lower end, with your thumb over the spanner-wrench hole, and lap the part in a straight line across the emery cloth. Do not apply downward pressure — the weight of the part alone provides sufficient pressure.
6	Lap the part, two or three times, in the same direction against the emery cloth. (See <a href="#">Figure 9.1 Reconditioning Stack Mating Surfaces</a> .)
7	Rotate the part 120 degrees, placing your thumb over the spanner-wrench hole, and repeat the lapping procedure in step 6.
8	Rotate the part another 120 degrees to the next spanner-wrench hole, and repeat the lapping procedure in step 6.
9	Re-examine the mating surface. If necessary, repeat steps 2-5 until you remove most of the contaminant. Remember, this should not require more than two to three complete rotations for an aluminum horn or booster; a titanium component may require more rotations.
10	<p>Before re-inserting a threaded stud in an aluminum booster or horn:</p> <p>Using a file card or wire brush, clean any aluminum bits from the knurled end of the stud.</p> <p>Using a clean cloth or towel, clean the threaded hole.</p> <p>Examine the knurled end of the stud. If worn, replace the stud. Also, examine the stud and threaded hole for stripped threads.</p> <p><b>NOTICE</b></p> <p>Threaded studs cannot be reused in titanium horns or boosters. Replace all studs in these components.</p>
11	Assemble and install the stack.

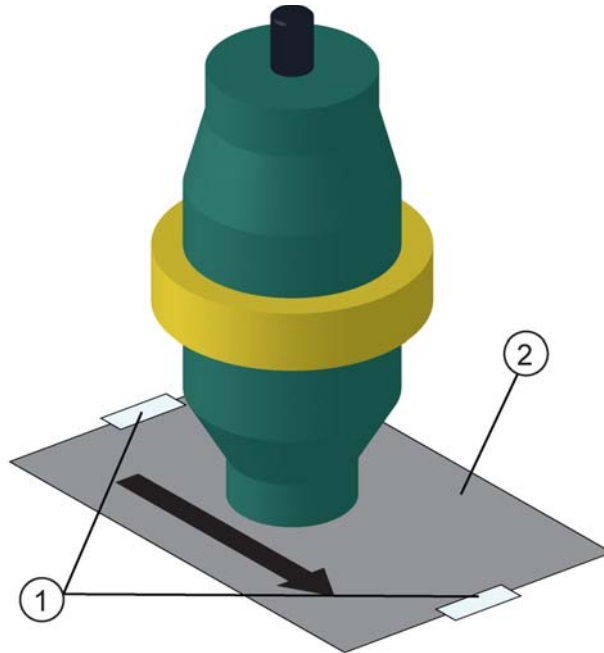

**Figure 9.1** Reconditioning Stack Mating Surfaces**Table 9.2** Reconditioning Stack Mating Surfaces

Item	Description
1	Tape
2	#400 Emery Cloth

### 9.2.3 Stack Torque Values

**Table 9.3** Stack Torque Values

Frequency	Torque
20 kHz	220 in·lb (25 N·m)
30 kHz	185 in·lb (21 N·m)
40 kHz	95 in·lb (11 N·m)

## For a 20 kHz System

**Table 9.4** Stack Reassembly for a 20 kHz System

Step	Action
1	Clean the mating surfaces of the converter, booster, and horn. Remove any foreign material from the threaded holes.
2	Install the threaded stud into the top of the booster. Torque to 450 in·lb (50.84 N·m). If the stud is dry, apply 1 or 2 drops of a light lubricating oil before installing.
3	Install the threaded stud into the top of the horn. Torque to 450 in·lb (50.84 N·m). If the stud is dry, apply 1 or 2 drops of a light lubricating oil before installing.
4	Install a single Mylar plastic film washer (matching the size of the washer to the stud) to each interface.
5	Assemble the converter to the booster and the booster to the horn.
6	Torque to 220 in·lb (24.85 N·m) at each interface.

## For a 30 kHz System

**Table 9.5** Stack Reassembly for a 30 kHz System

Step	Action
1	Clean the mating surfaces of the converter, booster, and horn. Remove any foreign material from the threaded holes.
2	Install the threaded stud into the top of the booster. Torque to 290 in·lb (32.76 N·m). If the stud is dry, apply 1 or 2 drops of a light lubricating oil before installing.
3	Install the threaded stud into the top of the horn. Torque to 290 in·lb (32.76 N·m). If the stud is dry, apply 1 or 2 drops of a light lubricating oil before installing.
4	Install a single Mylar plastic film washer (matching the size of the washer to the stud) to each interface.
5	Assemble the converter to the booster and the booster to the horn.
6	Torque to 185 in·lb (21 N·m) at each interface.

## For a 40 kHz System

**Table 9.6** Stack Reassembly for a 40 kHz System

Step	Action
1	Clean the mating surfaces of the converter, booster, and horn. Remove any foreign material from the threaded holes.
2	Apply a drop of Loctite®* 290 threadlocker (or equivalent) to the studs for the booster and horn.
3	Install the threaded stud into the top of the booster. Torque to 70 in·lb (7.91 N·m). Remove excess Loctite 290 threadlocker from the booster face and let cure for 30 minutes.
4	Install the threaded stud into the top of the horn. Torque to 70 in·lb (7.91 N·m). Remove excess Loctite 290 threadlocker from the horn face and let cure for 30 minutes.
5	Coat each interface surface with a thin film of silicon grease - but do not apply silicon grease to a threaded stud or tip.
6	Torque to 95 in·lb (10.73 N·m) at each interface.

\* Loctite is a registered trademark of Henkel Corporation, U.S.A.

### 9.2.4 Stud Torque Values

**Table 9.7** Stud Torque Values

Used on	Stud Size	Torque	EDP #
20 kHz	1/2 in x 20 x 1-1/4 in	450 in·lb, 50.84 N·m	100-098-370
	1/2 in x 20 x 1-1/2 in		100-098-123
30 kHz	3/8 in x 24 x 1 in	290 in·lb, 32.76 N·m	100-298-170R
40 kHz*	M8 x 1.25	70 in·lb, 7.91 N·m	100-098-790

\* Add a drop of Loctite 290 threadlocker to the stud. Torque and let cure for 30 minutes before using.

## 9.3 Recommended Spare Stock

This section provides lists of replacement parts, system cables, and suggested spares.

### 9.3.1 System Cables

You can order the following cables:

**Table 9.8** DCX F-EIP Power Supply System Cables

P/N	Description
100-240-383	Cable, RF 8 ft (2.5 m)
100-240-384	Cable, RF 15 ft (4.5 m)
100-240-385	Cable, RF 25 ft (7.5 m)
100-240-387	Cable, RF right angle 8 ft (2.5 m)
100-240-388	Cable, RF right angle 15 ft (4.5 m)
100-240-389	Cable, RF right angle 25 ft (7.5 m)
100-240-391	Cable, RF adaptor for CR20 converter 3 ft (0.9 m)
100-240-392	Cable, User I/O 25 ft (7.5 m)
100-240-393	Cable, User I/O 50 ft (15 m)
200-240-396	Cable Ethernet Cat 5e 7 ft (2.1 m)
100-240-397	Cable, RF adaptor for 4TR converter 3 ft (0.9 m)

### 9.3.2 Suggested Spares

**Table 9.9** Suggested Spares

Description	EDP#	1-4 Units	6-12 Units	14+ Units
Converter	Refer to <a href="#">Table 9.10 Converters Compatible with the DCX F-EIP Power Supply.</a>	0	1	2
Booster	Refer to <a href="#">Table 9.11 DCX F-EIP Power Supply Compatible Boosters.</a>	0	1	2
Horn	As Ordered	1	1	2
Studs	Refer to <a href="#">Table 9.12 Other Items used with the DCX F-EIP Power Supply.</a>	4	6	8
Mylar Plastic Film Washer Kit	Refer to <a href="#">Table 9.12 Other Items used with the DCX F-EIP Power Supply.</a>	1	1	1

## 9.3.3 Converters Compatible with the DCX F-EIP Power Supply

**Table 9.10** Converters Compatible with the DCX F-EIP Power Supply

Where used	Model	Connector	Part Number
20 kHz / 1250 W 20 kHz / 2500 W 20 kHz / 4000 W	CR-20*	3-pin MS connector	101-135-060R
	CR-20S	SHV connector	125-135-115R
	CR-20C	SHV connector with 3 ft (0.9 m) cable	159-135-210R
	CH-20S (932 AH SPL)	SHV connector	159-135-075R
	CH-20C	SHV connector with 3 ft (0.9 m) cable	159-135-211R
	CS-20S	SHV connector	159-135-138R
	CS-20C	SHV connector with 3 ft (0.9 m) cable	159-135-209R
30 kHz / 750 W 30 kHz / 1500 W	CR-30S	SHV connectors	101-135-081R
	CR-30C	SHV connector with 3 ft (0.9 m) cable	159-135-213R
	CH-30S	SHV connector	101-135-071R
	CH-30C	SHV connector with 3 ft (0.9 m) cable	159-135-214R
	CS-30S	SHV connector	159-135-110R
	CS-30C	SHV connector with 3 ft (0.9 m) cable	159-135-212R
40 kHz / 400 W 40 kHz / 800 W	4TR	3-pin MS connector	101-135-042R
	4TP	SHV connector (platen mount)	101-135-068R
	CR-40S (4TH)	SHV connector	101-135-067R
	CR-40C	SHV connector with 3 ft (0.9 m) cable	159-135-215R

\* Requires a special adaptor cable. See [Table 9.8 DCX F-EIP Power Supply System Cables](#).

### 9.3.4 DCX F-EIP Power Supply Compatible Boosters

**Table 9.11** DCX F-EIP Power Supply Compatible Boosters

Type of Booster	Description	Part Number
Solid Mount (1/2-20 horn stud) 20 kHz	Titanium, 1:0.6 (Purple)	101-149-095
	Titanium, 1:1 (Green)	101-149-096
	Titanium, 1:1.5 (Gold)	101-149-097
	Titanium, 1:2 (Silver)	101-149-098
	Titanium, 1:2.5 (Black)	101-149-099
Solid Mount (M8 x 1.25 horn stud) 40 kHz	Titanium, 1:0.6 (Purple)	109-041-178
	Titanium, 1:1 (Green)	109-041-177
	Titanium, 1:1.5 (Gold)	109-041-176
	Titanium, 1:2 (Silver)	109-041-175
	Titanium, 1:2.5 (Black)	109-041-174
Standard Series (1/2-20 horn stud) 20 kHz	Aluminum, 1:0.6 (Purple)	101-149-055
	Aluminum, 1:1 (Green)	101-149-051
	Aluminum, 1:1.5 (Gold)	101-149-052
	Aluminum, 1:2 (Silver)	101-149-053
	Titanium, 1:0.6 (Purple)	101-149-060
	Titanium, 1:1 (Green)	101-149-056
	Titanium, 1:1.5 (Gold)	101-149-057
	Titanium, 1:2 (Silver)	101-149-058
Standard Series (3/8-24 horn stud) 30 kHz	Titanium, 1:2.5 (Black)	101-149-103
	Titanium, 1:2 (Silver)	101-149-104
	Titanium, 1:1.5 (Gold)	101-149-105
	Titanium, 1:1 (Green)	101-149-106

**Table 9.11** DCX F-EIP Power Supply Compatible Boosters

Type of Booster	Description	Part Number
Standard Series (M8 x 1.25 horn stud) 40 kHz	Aluminum, 1:0.6 (Purple)	101-149-087
	Aluminum, 1:1 (Green)	101-149-079
	Aluminum, 1:1.5 (Gold)	101-149-080
	Aluminum, 1:2 (Silver)	101-149-081R
	Aluminum, 1:2.5 (Black)	101-149-082
	Titanium, 1:1 (Green)	101-149-085
	Titanium, 1:1.5 (Gold)	101-149-086
	Titanium, 1:2 (Silver)	101-149-083
	Titanium, 1:2.5 (Black)	101-149-084



### 9.3.5 Other Items used with the DCX F-EIP Power Supply

**Table 9.12** Other Items used with the DCX F-EIP Power Supply

Product	Description	Part No.
Silicone grease	For use with 40 kHz systems	101-053-002
Mylar Plastic Film Washers (for 20 kHz systems)	Kit, 10 each (1/2 in. and 3/8 in.)	100-063-357
	Kit, 150 each (1/2 in.)	100-063-471
	Kit, 150 each (3/8 in.)	100-063-472
Mylar Plastic Film Washers (for 30 kHz systems)	Kit, 10 each (3/8 in.)	100-063-632
	Kit, 150 each (3/8 in.)	100-063-712
Tool Kit	20 kHz (spanner wrench and 10 pc washer kit)	101-063-208R
	30 kHz (spanner wrench and 10 pc washer kit)	101-063-636R
	40 kHz (spanner wrench and silicone grease)	101-063-176R
Spanner wrench	20 kHz	101-118-039
	30 kHz	201-118-033
	40 kHz	201-118-024
Studs	1/2-20 x 1-1/4 (titanium horns)	100-098-370
	1/2-20 x 1-1/2 (aluminum horns, 20 kHz boosters)	100-098-123
	3/8-24 x 1 (30 kHz titanium horns and boosters)	100-298-170
	M-8 x 1.25 (40 kHz horns and boosters)	100-098-790
Fan Filter*	For small size units (400 W, 750 W, and 800 W)	101-063-936
	For medium size units (1250 W, and 1500 W)	101-063-935
	For large size units (2500 W, and 4000 W)	101-063-934
Connector Block	Detachable connector block	200-029-1081
Top Mounting Plate	Top mounting plate for vertical units.	100-079-462
Bottom Mounting Plate	Bottom mounting plate for vertical units.	100-079-463

\*When using a fan filter on a DCX F-EIP Power Supply, the maximum output power must be derated by 10%.

## 9.4 Circuit Diagram

Figure 9.2 Interconnect Diagram, Power Supply

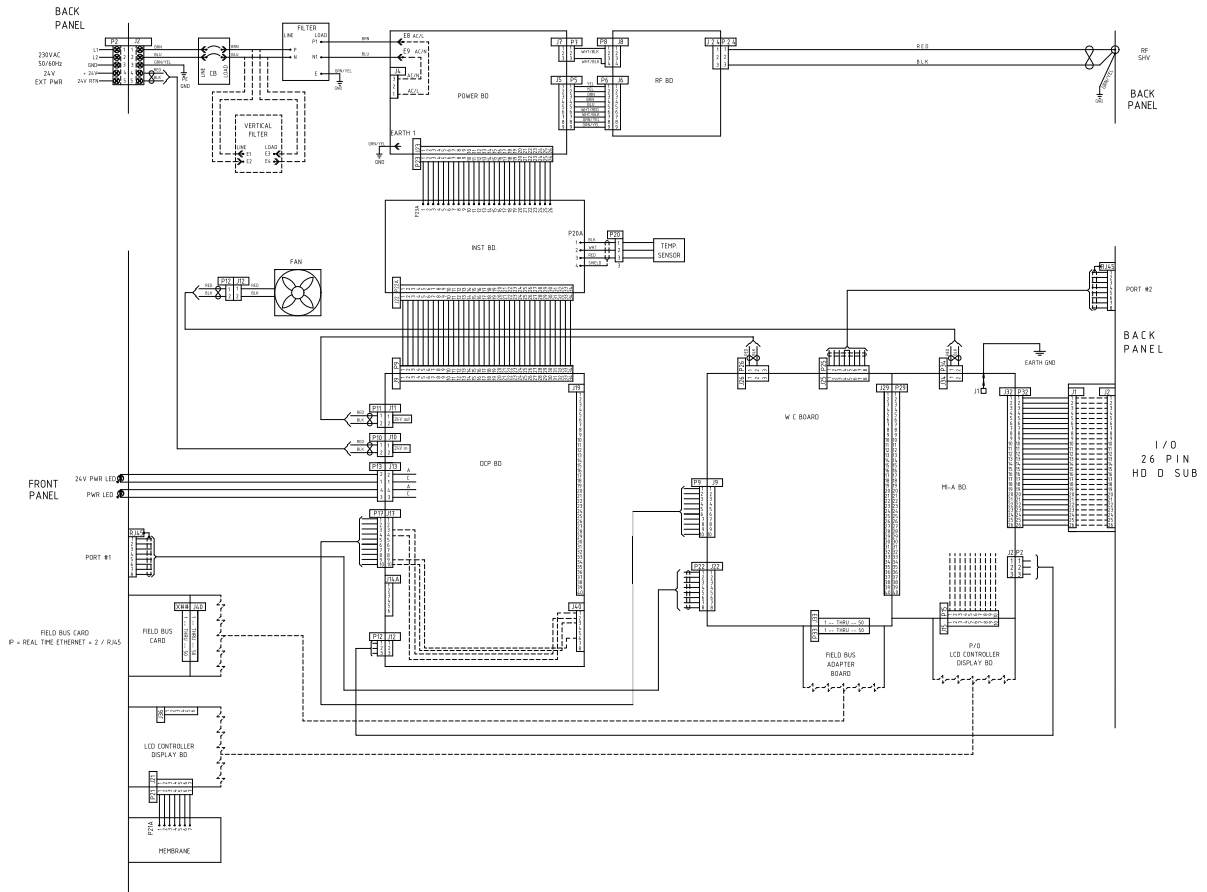

## 9.5 Troubleshooting

If you have a problem operating the DCX F-EIP Power Supply, take the following steps:

**Table 9.13** Troubleshooting

Step	Action
1	Make sure the converter-booster-horn stack is properly assembled and installed.
2	For instructions on reconditioning stack component surfaces, refer to <a href="#">9.2.2 Recondition the Stack (Converter, Booster, and Horn)</a> .
3	If you need additional help, call your local Branson representative, refer to <a href="#">1.4 How to Contact Branson</a> .

NOTICE	
	DCX F-EIP Power Supply should be serviced only by qualified technicians using Branson-approved test and repair equipment, repair procedures, and replacement parts. Unauthorized attempts at repair or modification of the power supply will void the warranty.

## 9.5.1 Common Electrical Problems

NOTICE	
	<p>If the circuit breaker fails more than once, this usually indicates that another component has failed. Continue troubleshooting other components.</p>

**Table 9.14** Troubleshooting Common Electrical Problems

Problem	Check	Solution
Main circuit breaker trips when plugging the power supply into an electrical outlet.	Inspect line connection cables.	If failed, replace.
Main circuit breaker trips during weld cycle.	Check current rating of the main circuit breaker.	If failed, replace.
Main circuit breaker fails during power up.	Check main circuit breaker current rating.	If incompatible, replace main circuit breaker.
When touching a component of the weld system, you get a slight electrical shock.	Ensure the Ground cable is connected properly.	N/A
	Inspect the line cables.	If failed, repair or replace.
Fan does not operate when is tested on the Diagnostic User I/O Web Page.	Fan motor has failed.	Return for repair.

## 9.5.2 Ultrasonic Power Problems

**Table 9.15** Troubleshooting Ultrasonic Power Problems

Problem	Check	Solution
Ultrasonic power delivered to horn; no indication on bar graph.	Check connector cables, replace if failed.	Replace defective cables.
	Test power supply.	See <a href="#">7.6 Ultrasonics Test Procedure</a> .
No ultrasonic power generated when Test key pressed; no Alarm indicator.	Failed or missing stack.	Replace.
	RF cable unplugged or failed; replace if failed.	Plug in or replace.
	Test power supply ( <a href="#">7.6 Ultrasonics Test Procedure</a> ).	If defective, send unit for repair.
Unable to adjust amplitude using the front panel keypad.	Register setting configured to "External Amplitude Control"	Reset if required, See <a href="#">7.4 Configuring the Power Supply Registers</a> .
Unable to remote control.	User I/O cable	Repair or replace.
	Customer's switching device	Test/inspect/repair/replace.

## 9.5.3 Weld Cycle Problems

**Table 9.16** Troubleshooting Weld Cycle Problems

Problem	Check	Solution
Full ultrasonic power not delivered.	Unsuitable horn or booster selection.	Contact Branson Applications Lab
	Plastic part material varies.	
	Mold release lubricant in weld area.	
	Unsuitable joint design.	
	Unsuitable or misaligned part fixture.	
	Amplitude setting	
No ultrasonic power passed to horn.	Power supply overheating; check fan and vents.	If defective, send unit for repair.
Alarm indicator illuminates when you press the Test key or during the weld cycle.	Check converter-booster-horn stack interface for fretting corrosion.	See <a href="#">9.2.2 Recondition the Stack (Converter, Booster, and Horn)</a> .
	Check for loose or failed horn converter or booster.	Tighten or replace as needed.
	Check for loose or failed horn or booster stud.	
	Failed RF cable	Replace if failed.
Excessively warm horn, booster, and converter; occasional overloads.	Check converter-booster-horn stack mating surfaces for fretting corrosion.	See <a href="#">9.2.2 Recondition the Stack (Converter, Booster, and Horn)</a> .
	Be certain proper cooling has been provided.	If defective, send unit for repair.

## 9.6 Cold Start Procedure

The power supply internal memory stores the system default settings and the registers that you set. It also provides temporary storage to support the power supply internal functions. A cold start clears and restores all the power supply settings back to the original factory defaults. It is not necessary to perform a cold start during normal operation and servicing, but you might find a cold start helpful when:

- You suspect the system is not operating properly
- You want to make a new setup
- Some system memory registers, such as Software version, will not be cleared by this Cold Start procedure

### 9.6.1 Performing a Cold Start

NOTICE	
	<p>Using the Cold Start procedure will erase the current Amplitude Setting, the IP address and some of the Registers that you set. Be sure you have a record of your setup if you want to retain it or use the system backup feature from the DCX F-EIP Power Supply Web Page Interface.</p>

**Table 9.17** Steps to Perform a Cold Start

Step	Action
1	Turn off the power supply.
2	Connect together pins 4 and 10 on the 26-pin User I/O Connector.
3	Turn on the power supply.
4	After the power up sequence ends, turn off the power supply
5	Disconnect pins 4 and 10 of the 26-pin on User I/O Connector.





---

## Appendix A: Alarms

---

A.1	Overload Alarms (Group 0) . . . . .	190
A.2	Cutoff Alarms (Group 1) . . . . .	192
A.3	Setup Alarms (Group 2) . . . . .	193
A.4	Cycle Modified Alarms (Group 3) . . . . .	194
A.5	Warning Alarms (Group 4) . . . . .	195
A.6	Limit Alarms (Group 5) . . . . .	196
A.7	Equipment Failure Alarms (Group 6) . . . . .	197
A.8	No Cycle Alarms (Group 7) . . . . .	199
A.9	Communication Failure Alarms (Group 8) . . . . .	200
A.10	Hardware Alarms (Group A) . . . . .	201
A.11	Non-Cycle Overload Alarms (Group B) . . . . .	202

## A.1 Overload Alarms (Group 0)

This group includes all overload alarms that can occur during a weld cycle. This overload group will abort the weld cycle after stopping the sonics.

**Table A.1** Overload Alarms (Group 0)

Alarm Code	Bit Assignment	Alarm	Description
001	Bit01	Weld Overload - Phase	This alarm is generated in case of weld phase is out of weld phase limit for weld phase limit time period.
002	Bit02	Weld Overload - Current	This alarm is generated in case of weld current reaches to peak RF current limit of the system.
003	Bit03	Weld Overload - Frequency	This alarm is generated in case of weld frequency is out of weld frequency low and high limit window.
004	Bit04	Weld Overload - Power	This alarm is generated in case of weld power reaches to peak RF power limit of the system.
005	Bit05	Weld Overload - Voltage	This alarm is generated in case of voltage during weld reaches to peak RF voltage limit of the system.
006	Bit06	Weld Overload - Temperature	This alarm is generated in case of temperature inside the system (at the heat sink) reaches to 85° C ( $\pm 5^\circ$ C).  <b>NOTICE</b> Alarm cannot be cleared until the temperature returns below threshold.
011	Bit17	Energy Brake Overload - Phase	This alarm is generated in case of phase is out of weld phase limit for weld phase limit time period during energy breaking.
012	Bit18	Energy Brake Overload - Current	This alarm is generated in case of weld current reaches to peak RF current limit of the system during energy breaking.
013	Bit19	Energy Brake Overload - Frequency	This alarm is generated in case of weld frequency is out of weld frequency low and high limit window during energy breaking.
014	Bit20	Energy Brake Overload - Power	This alarm is generated in case of weld power reaches to peak RF power limit of the system during energy breaking.

**Table A.1** Overload Alarms (Group 0)

<b>Alarm Code</b>	<b>Bit Assignment</b>	<b>Alarm</b>	<b>Description</b>
015	Bit21	Energy Brake Overload - Voltage	This alarm is generated in case of voltage during weld reaches to peak RF voltage limit of the system during energy breaking.

## A.2 Cutoff Alarms (Group 1)

This groups includes all cutoff alarms. Cutoff alarms are defined as a limit on a parameter, that when exceeded, will stop ultrasonics. The remaining portion of a weld cycle will continue.

**Table A.2** Cutoff Alarms (Group 1)

Alarm Code	Bit Assignment	Alarm	Description
102	Bit02	Energy Cutoff	Energy cutoff alarm is generated if the energy value during sonics on exceeded to the set cutoff value during a weld.
103	Bit03	Power Cutoff	Power cutoff alarm is generated if the peak power value during sonics on exceeded to the set cutoff value.
104	Bit04	Custom Input1 Cutoff	User can configure one of the user analog input as a Custom Input1 and also set a cutoff value from that input. System will generate custom Input1 Cutoff alarm if the user input voltage exceeds from the cutoff value set by user.
105	Bit05	Time Cutoff (Maximum Time-out)	User can set a time cutoff for weld and the alarm will be generated if the sonic on time during weld exceeds to the set value.
106	Bit06	Frequency Low Cutoff	User can set frequency low cutoff (negative offset to be applied from weld start frequency) for weld and the alarm will be generated if the frequency during weld goes below to the weld start frequency minus set value.
107	Bit07	Frequency High Cutoff	User can set frequency high cutoff (positive offset to be applied from weld start frequency) for weld and the alarm will be generated if the frequency during weld goes above to the weld start frequency plus set value.
108	Bit08	Custom Input2 Cutoff	User can configure one of the user analog input as a Custom Input2 and also set a cutoff value from that input. System will generate Custom Input2 cutoff alarm if the user input voltage exceeds from the cutoff value set by user.

## A.3 Setup Alarms (Group 2)

This group includes all alarms that can occur during setup.

**Table A.3** Cycle Modified Alarms (Group 2)

Alarm Code	Bit Assignment	Alarm	Description
203	Bit02	Invalid Preset	Recalling invalid preset. Preset > 32.

## A.4 Cycle Modified Alarms (Group 3)

Cycle modified alarms cause the cycle to be modified from the intended parameters. This can be caused by the user or equipment conditions changing. This group of alarms will always abort the cycle.

**Table A.4** Cycle Modified Alarms (Group 3)

Alarm Code	Bit Assignment	Alarm	Description
301	Bit01	Trigger Lost During Weld Or Hold	This alarm is generated during a weld cycle in case actuator is present and trigger input is lost before completing the weld (in case of time, energy, peak power and ground detect mode).
302	Bit02	Cycle Aborted Via User I/O	This alarm is generated if user aborts the cycle using cycle abort user input.

## A.5 Warning Alarms (Group 4)

Warnings occur when a condition is happening that may have been unexpected. This group of alarms does not abort the cycle. This group includes overloads during afterburst because they do not abort the cycle.

**Table A.5** Warning Alarms (Group 4)

Alarm Code	Bit Assignment	Alarm	Description
404	Bit04	Amplitude Step Not Reached	This alarm is generated if Amplitude Stepping is ON but weld cycle finishes before stepping take places.
405	Bit05	Sonics Disabled Via User I/O	This alarm indicates the user has enabled an input pin as "Sonics Disable" and has run a cycle with this input active.
411	Bit17	Afterburst Overload - Phase	This alarm is generated in case of afterburst phase is out of Weld Phase limit for Weld Phase limit time period.
412	Bit18	Afterburst Overload - Current	This Alarm is generated in case of weld current reaches to peak RF current limit of the system during afterburst.
413	Bit19	Afterburst Overload - Frequency	This alarm is generated in case of Weld Frequency is out of Weld Frequency Low and High limit window during afterburst.
414	Bit20	Afterburst Overload - Power	This alarm is generated in case of weld power reaches to peak RF power limit of the system during afterburst.
415	Bit21	Afterburst Overload - Voltage	This alarm is generated in case of weld voltage reaches to peak RF voltage limit of the system during afterburst.
416	Bit22	Afterburst Overload - Temperature	The internal heat sink temperature is greater than allowed. <b>NOTICE</b> Alarm cannot be cleared until the temperature returns below threshold.

## A.6 Limit Alarms (Group 5)

Limits will be reported at the end of the weld, but, unlike cutoffs, will not stop the sonics or abort the cycle.

**Table A.6** Limit Alarms (Group 5)

Alarm Code	Bit Assignment	Alarm	Description
503	Bit03	Power - Minus Limit	This alarm is generated at the end of the cycle in case that Weld peak power is lower than the Power Minus limit.
504	Bit04	Power - Plus Limit	This alarm is generated at the end of the cycle in case that Weld peak power is bigger than the Power Plus limit.
505	Bit05	Time - Minus Limit	This alarm is generated at the end of the cycle in case that Weld time is lower than the Time Minus limit.
506	Bit06	Time - Plus Limit	This alarm is generated at the end of the cycle in case that Weld time is bigger than the time Plus limit.
507	Bit07	Energy - Minus Limit	This alarm is generated at the end of the cycle in case that Weld energy is lower than the energy Minus limit.
508	Bit08	Energy - Plus Limit	This alarm is generated at the end of the cycle in case that Weld energy is bigger than the energy Plus limit.



## A.7 Equipment Failure Alarms (Group 6)

Equipment alarms are caused by user equipment malfunction. These alarms occur before a cycle starts and therefore, will prevent a cycle from starting until the malfunction is corrected.

NOTICE	
	Alarm message will not reset until the malfunction is corrected.

**Table A.7** Equipment Failure Alarms (Group 6)

Alarm Code	Bit Assignment	Alarm	Description
601	Bit01	Start Input Still Active	This alarm is generated if External Start/Cycle Start/Trigger signal is active for more than 4 seconds after finishing the weld or while system is waiting to come into ready state.
602	Bit02	Trigger Active While ULS Active	This alarm is generated any time if Trigger and ULS both becomes active.
603	Bit03	Trigger Active In Ready	This alarm is generated if Trigger signal becomes active while system is in ready state and actuator is present.
604	Bit04	ULS Not Active In Ready	This alarm is generated if actuator is present and ULS is not active while system is already in ready state.
605	Bit05	Ground Detect Active In Ready	This alarm is generated if ground detect signal becomes active while system is in ready state.
607	Bit07	Cable Failure - User I/O	The cable detect user I/O feature has been enabled and detected that the assigned pin does not have the voltage applied.
608	Bit08	Field Bus Removed	Communication between the internal field bus card and the internal weld controller has failed.
609	Bit09	Start Input Lost	This alarm is generated when source of cycle start is removed before Trigger comes.

**Table A.7** Equipment Failure Alarms (Group 6)

Alarm Code	Bit Assignment	Alarm	Description
610	Bit16	Cycle Abort In Ready	This alarm is generated if Cycle Abort signal becomes active while system is in ready state.
611	Bit17	ULS Time Out	This alarm is generated if Actuator is present and ULS does not become active with a time-out at the end of the cycle.
612	Bit18	ULS Active During Weld	This alarm is generated if System is waiting for TRS and ULS becomes active. After TRS is active and system jumps to next state of cycle this alarm is generated when ULS becomes active during cycle along with "TRS active while ULS Active" alarm.

## A.8 No Cycle Alarms (Group 7)

No cycle alarms are caused by possible mechanical setup errors or user errors. These are usually time out errors because an expected input did not occur in time. They will prevent a cycle from continuing. So although a cycle may have started, the cycle will be aborted.

**Table A.8** No Cycle Alarms (Group 7)

Alarm Code	Bit Assignment	Alarm	Description
701	Bit01	ULS Time-Out (Start Of Cycle)	A cycle start has been received but the upper limit switch has not gone inactive within the time-out specified by the system.
702	Bit02	Trigger Time-Out	A cycle has been started, but the trigger input has not gone active within the time-out specified by the system.
703	Bit03	External Sonics Delay Time-Out (User I/O)	The system is waiting for an external user defined input (if configured), but has not received the input within the time-out specified by the system.
704	Bit04	Interlock Not In Place (User I/O)	The system is waiting for a valid status from a user defined Interlock input (if configured), but the input is not active at the time of Cycle start.
705	Bit05	RF Switch Feedback Failure	A feedback signal from the RF switch not was not received within the time specified by the user.
706	Bit06	Part Not In Place (User I/O)	The system is waiting for an external user defined input, but the input is not active at the Cycle Start.
707	Bit07	Stack Number Not Valid For RF Switching	An invalid horn number is being requested from the preset. Any values outside the range of 16 horn numbers will cause an alarm.

## A.9 Communication Failure Alarms (Group 8)

This group handles any communication issue that occur between processors. This is generally the result of noisy environments or other conditions that interrupt communications. Physical cable failures will be included in the Hardware Failure group. Because data cannot be transmitted between internal hardware, the cycle will be aborted.

NOTICE	
	Alarm message will not reset until the malfunction is corrected.

**Table A.9** Communication Failure Alarms (Group 8)

Alarm Code	Bit Assignment	Alarm	Description
801	Bit01	Modbus Communication Failure	Internal communication failure.
802	Bit02	LCD Communication Failure	Communication between the LCD user interface and the internal weld controller has failed.
803	Bit03	Fieldbus Communication Failure	The field bus was detected at power on, but is no longer responding. Either the cable has been removed or the field bus master has stop working. If the system is powered down and field bus is not detected at power up, then the system can still be used without the field bus.

## A.10 Hardware Alarms (Group A)

This group of alarms will deal with internal equipment failures. This will generally be equipment that is supplied by Branson as part in the internal workings of the power supply. Cycles cannot be started if there is a Hardware alarm. If a cycle is in process when the alarm is detected then the cycle is aborted.

NOTICE	
	Alarm message will not reset until the malfunction is corrected.

**Table A.10** Hardware Alarms (Group A)

Alarm Code	Bit Assignment	Alarm	Description
A01	Bit01	LCD NOVRAM Failure	LCD NOVRAM is not working.
A02	Bit02	FRAM or NOVRAM Failure	FRAM or NOVRAM is not working.
A03	Bit03	SD RAM Failure	SD RAM is not working.
A04	Bit04	Connection Failure - WC to LCD	The physical connection between the WC board and LCD board is missing or broken.
A05	Bit05	Connection Failure - WC to DCP	The physical connection between the WC board and DCP board is missing or broken.
A06	Bit06	AC Line Voltage Lost	The AC line voltage to the system is lost but the 24 V supply is still present. After clearing the alarm, the system will run a Seek, Scan, or only power up, depending on the selected action in the Seek/Power Up Setup menu.
			ES bit activated, check ZSW1 Low Byte

## A.11 Non-Cycle Overload Alarms (Group B)

This group deals with overloads that occur outside of a weld cycle. By definition a weld is not in process so the weld cycle counter is not affected and the weld is not aborted.

**Table A.11** Non-Cycle Overload Alarms (Group B)

Alarm Code	Bit Assignment	Alarm	Description
b01	Bit01	Seek Overload - Phase	This alarm is generated in case of phase during Seek reaches to peak RF phase limit of the system.
b02	Bit02	Seek Overload - Current	This alarm is generated in case of current during Seek reaches to peak RF current limit of the system.
b03	Bit03	Seek Overload - Frequency	This alarm is generated in case of Frequency during seek is out of Seek Frequency Low and High limit window.
b04	Bit04	Seek Overload - Power	This alarm is generated in case of Power during seek reaches to peak RF Power limit of the system.
b05	Bit05	Seek Overload - Voltage	This alarm is generated in case of Voltage during seek reaches to peak RF voltage limit of the system.
b06	Bit06	Seek Overload - Temperature	This alarm is generated in case of temperature inside the system (at the heat sink) reaches to 85° C ( $\pm 5^\circ$ C) during Seek. <b>NOTICE</b> Alarm cannot be cleared until the temperature returns below threshold.
b11	Bit17	Test Overload - Phase	This alarm is generated in case of phase during Test reaches to peak RF phase limit of the system.
b12	Bit18	Test Overload - Current	This alarm is generated in case of current during Test reaches to peak RF current limit of the system.
b13	Bit19	Test Overload - Frequency	This alarm is generated in case of Frequency during seek is out of Test Frequency Low and High limit window.
b14	Bit20	Test Overload - Power	This alarm is generated in case of Power during Test reaches to peak RF Power limit of the system.
b15	Bit21	Test Overload - Voltage	This Alarm is generated in case of Voltage during Test reaches to peak RF voltage limit of the system.

**Table A.11** Non-Cycle Overload Alarms (Group B)

Alarm Code	Bit Assignment	Alarm	Description
b16	Bit22	Test Overload - Temperature	<p>This alarm is generated in case of temperature inside the system (at the heat sink) reaches to 85° C (<math>\pm 5^{\circ}</math> C) during Test.</p> <p><b>NOTICE</b> Alarm cannot be cleared until the temperature returns below threshold.</p>





---

## **Appendix B: EtherNet/IP Commands**

---

<b>B.1</b>	<b>Parameter Set Class 100 (32 Instances) . . . . .</b>	<b>206</b>
<b>B.2</b>	<b>Weld Data Class 101 (32 Instances) . . . . .</b>	<b>209</b>
<b>B.3</b>	<b>Stack Parameter Class 102 (16 Instances) . . . . .</b>	<b>211</b>
<b>B.4</b>	<b>Common Stack Parameters (16 Instances) . . . . .</b>	<b>212</b>
<b>B.5</b>	<b>Stack Status Class 103 (16 Instances) . . . . .</b>	<b>213</b>
<b>B.6</b>	<b>Alarm Data Class 104 (1 Instances) . . . . .</b>	<b>216</b>
<b>B.7</b>	<b>System Information Class 105 (1 Instances) . . . . .</b>	<b>217</b>
<b>B.8</b>	<b>Other Information Class 112 (1 Instances) . . . . .</b>	<b>218</b>
<b>B.9</b>	<b>Identity Object 1 (1 Instance) . . . . .</b>	<b>219</b>

## B.1 Parameter Set Class 100 (32 Instances)

Each instance refers to the preset number.

**Table B.1** Parameter Set Class

Attribute ID	Name	Data Type	Access	Default	Min.	Max.	Format	Unit
1010	Preset Name (Character 1)	AINT8	Get/Set	64	32	128	-	-
1011	Preset Name (Character 2)	AINT8	Get/Set	64	32	128	-	-
1012	Preset Name (Character 3)	AINT8	Get/Set	64	32	128	-	-
1013	Preset Name (Character 4)	AINT8	Get/Set	64	32	128	-	-
1014	Preset Name (Character 5)	AINT8	Get/Set	64	32	128	-	-
1015	Preset Name (Character 6)	AINT8	Get/Set	64	32	128	-	-
1016	Preset Name (Character 7)	AINT8	Get/Set	64	32	128	-	-
1017	Preset Name (Character 8)	AINT8	Get/Set	64	32	128	-	-
1018	Preset Name (Character 9)	AINT8	Get/Set	64	32	128	-	-
1019	Preset Name (Character 10)	AINT8	Get/Set	64	32	128	-	-
1020	Preset Name (Character 11)	AINT8	Get/Set	64	32	128	-	-
1021	Preset Name (Character 12)	AINT8	Get/Set	64	32	128	-	-
1022	Preset Name (Character 13)	AINT8	Get/Set	64	32	128	-	-
1023	Preset Name (Character 14)	AINT8	Get/Set	64	32	128	-	-
1024	Preset Name (Character 15)	AINT8	Get/Set	64	32	128	-	-
1025	Preset Name (Character 16)	AINT8	Get/Set	64	32	128	-	-
1026	Preset Name (Character 17)	AINT8	Get/Set	64	32	128	-	-
1027	Preset Name (Character 18)	AINT8	Get/Set	64	32	128	-	-
1028	Preset Name (Character 19)	AINT8	Get/Set	64	32	128	-	-
1029	Preset Name (Character 20)	AINT8	Get/Set	64	32	128	-	-
1040	Horn number assigned to a preset	AUINT8	Get/Set	1	1	16	-	-
1060	Weld Mode (0=Continuous 1=Time 2=Energy 3=Peak Power 4=Ground Detect)	AINT32	Get/Set	0	0	4		
1061	Time	AINT32	Get/Set	10	10	30000		ms
1062	Energy (Value should be entered 10 times higher)	AINT32	Get/Set	10	1	99990		0.1xJ
1063	Peak Power	AINT32	Get/Set	1	1	100		%
1064	Ground Detect Time	AINT32	Get/Set	1	0	500		ms
1065	Amplitude A	AINT32	Get/Set	100	10	100		%
1066	Amplitude B	AINT32	Get/Set	100	10	100		%
1067	Amplitude Profile Criterion (0=Fix, 1=External analog in 2=Step@Time 3=Step@Energy 4=Step@Power 5=Step@External)	AINT32	Get/Set	0	0	5	Selection	-

**Table B.1** Parameter Set Class

Attribute ID	Name	Data Type	Access	Default	Min.	Max.	Format	Unit
1068	Amplitude Profile Time	AINT32	Get/Set	10	1	30000		ms
1069	Amplitude Profile Energy (Value should be entered 10 times higher)	AINT32	Get/Set	10	1	99990		0.1xJ
1070	Amplitude Profile Peak Power	AINT32	Get/Set	1	1	100		%
1071	Amplitude Start Ramp Time	AINT32	Get/Set	80	10	1000		ms
1072	Amplitude Profile Ramp Time	AINT32	Get/Set	80	10	1000		ms
1073	Frequency Store at End	AINT32	Get/Set	1	0	1	Selection	
1074	Frequency Offset	AINT32	Get/Set	0	-500	500		Hz
1075	Hold time	AINT32	Get/Set	10	10	30000	0=OFF	ms
1076	Energy Breaking	AINT32	Get/Set	1	0	1	Selection	
1077	EB Target Amplitude	AINT32	Get/Set	3	1	100		%
1078	EB Time	AINT32	Get/Set	20	10	1000		ms
1079	After Burst	AINT32	Get/Set	1	0	1	Selection	
1080	AB Amplitude	AINT32	Get/Set	100	10	100		%
1081	AB Time	AINT32	Get/Set	100	100	2000		ms
1082	AB Delay	AINT32	Get/Set	100	100	2000		ms
1084	Scrub Amplitude	AINT32	Get/Set	100	10	100		%
1086	Time Error High (Cutoff)	AINT32	Get/Set	6000	10	30000	0=OFF	ms
1087	Energy Error High (Cutoff) (Value should be entered 10 times higher)	AINT32	Get/Set	1	1	99990	0=OFF	0.1xJ
1088	Peak Power Error High (Cutoff)	AINT32	Get/Set	10	1	100	0=OFF	%
1089	- Time Limit	AINT32	Get/Set	10	10	30000	0=OFF	ms
1090	+ Time Limit	AINT32	Get/Set	30000	10	30000	0=OFF	ms
1091	- Energy Limit (Value should be entered 10 times higher)	AINT32	Get/Set	1	1	99990	0=OFF	0.1xJ
1092	+ Energy Limit (Value should be entered 10 times higher)	AINT32	Get/Set	99990	1	99990	0=OFF	0.1xJ
1093	- Peak Power Limit	AINT32	Get/Set	1	1	100	0=OFF	%
1094	+ Peak Power Limit	AINT32	Get/Set	100	1	100	0=OFF	%
1095	Frequency Low (Cutoff Relative) (It depends on the power supply operating frequency)	AINT32	Get/Set	20 kHz: 500	20 kHz: 1	20 kHz: 500	0=OFF	Hz
				30 kHz: 750	30 kHz: 1	30 kHz: 750		
				40 kHz: 1000	40 kHz: 1	40 kHz: 1000		
1096	Frequency High (Cutoff Relative) (It depends on the power supply operating frequency)	AINT32	Get/Set	20 kHz: 500	20 kHz: 500	20 kHz: 500	0=OFF	Hz
				30 kHz: 750	30 kHz: 1	30 kHz: 750		
				40 kHz: 1000	40 kHz: 1	40 kHz: 1000		

## B.1.1 Common Services

**Table B.2** Common Services

Service Code	Service Name
14	Get_Attribute_Single
16	Set_Attribute_Single

## B.2 Weld Data Class 101 (32 Instances)

The weld data for the preset number run.

**Table B.3** Weld Data Class

Attribute ID	Description	Data Type	Access	Format	Unit
1210	Preset Name (Character 1)	AINT8	Get	-	-
1211	Preset Name (Character 2)	AINT8	Get	-	-
1212	Preset Name (Character 3)	AINT8	Get	-	-
1213	Preset Name (Character 4)	AINT8	Get	-	-
1214	Preset Name (Character 5)	AINT8	Get	-	-
1215	Preset Name (Character 6)	AINT8	Get	-	-
1216	Preset Name (Character 7)	AINT8	Get	-	-
1217	Preset Name (Character 8)	AINT8	Get	-	-
1218	Preset Name (Character 9)	AINT8	Get	-	-
1219	Preset Name (Character 10)	AINT8	Get	-	-
1220	Preset Name (Character 11)	AINT8	Get	-	-
1221	Preset Name (Character 12)	AINT8	Get	-	-
1222	Preset Name (Character 13)	AINT8	Get	-	-
1223	Preset Name (Character 14)	AINT8	Get	-	-
1224	Preset Name (Character 15)	AINT8	Get	-	-
1225	Preset Name (Character 16)	AINT8	Get	-	-
1226	Preset Name (Character 17)	AINT8	Get	-	-
1227	Preset Name (Character 18)	AINT8	Get	-	-
1228	Preset Name (Character 19)	AINT8	Get	-	-
1229	Preset Name (Character 20)	AINT8	Get	-	-
1240	Horn #	-	-	-	-
1241	Mode (0=Continuous 1=Time 2=Energy 3=Peak Power 4=Ground Detect)	-	-	-	-
1306*	Date (DD/MM/YY)	-	-	-	-
1307**	Time (SS:MM:HH)	-	-	-	-
1308***	Cycle Counter	-	-	-	-
1309-1357	Same as Class 67 attributes 1630-1678	-	-	-	-
1360	Weld Time	AINT32	Get		ms
1361	Hold Time	AINT32	Get		ms
1362	Energy	AINT32	Get		0.1 J
1363	Peak Power	AINT32	Get		%
1364	Average Power	AINT32	Get		%
1365	Average Amplitude 1	AINT32	Get		%
1366	Average Amplitude 2	AINT32	Get		%

**Table B.3** Weld Data Class

Attribute ID	Description	Data Type	Access	Format	Unit
1367	Recalled Res. Frequency	AINT32	Get		Hz
1368	Start Frequency	AINT32	Get		Hz
1369	End Frequency	AINT32	Get		Hz
1370	Stored Frequency	AINT32	Get		Hz
1371	Res. Frequency OK	AINT32	Get	Selection	
1372	End Amplitude Set	AINT32	Get		%
1373	End Amplitude	AINT32	Get		%
1374	End PSV	AINT32	Get		%
1375	End Power	AINT32	Get		%
1376	End Current	AINT32	Get		%
1377	End Phase	AINT32	Get		deg. (°)
1378	End Temperature	AINT32	Get		°C

\*(Date) It's given in the order: day, month, year - for example 180810

18 Hex = 24 decimal = day

08 Hex = 08 decimal = month

10 Hex = 16 decimal = year

Date = 24/08/16

\*\* (Time) It's given in the order: seconds, minutes, hours - for example 371E0F

37 Hex = 55 decimal = seconds

1E Hex = 30 decimal = minutes

0F Hex = 15 decimal = hours

Time = 15:30:55

\*\*\*ID 1308 is a 32-bit long command.

## B.2.1 Common Services

**Table B.4** Common Services

Service Code	Service Name
14	Get_Attribute_Single

## B.3 Stack Parameter Class 102 (16 Instances)

There is one instance for each horn preset. Attributes 1460-1465 are for seek, and 1475 is for test.

**Table B.5** Stack Parameter Class (Seek Results)

Attribute ID	Description	Data Type	Access	Default	Min.	Max.	Format	Unit
1460	Time	AINT32	Get/Set	500	10	1000		ms
1462	Amplitude Start Ramp Time	AINT32	Get/Set	80	10	1000		ms
1465	Frequency Offset	AINT32	Get/Set	0	-500	500		Hz

**Table B.6** Stack Parameter Class (Test Results)

Attribute ID	Description	Data Type	Access	Default	Min.	Max.	Format	Unit
1475	Test Amplitude	AINT32	Get/Set	100	10	100	-	%

### B.3.1 Common Service

**Table B.7** Common Services

Service Code	Service Name
14	Get_Attribute_Single
16	Set_Attribute_Single

## B.4 Common Stack Parameters (16 Instances)

**Table B.8** Common Stack Parameters

Attribute ID	Description	Data Type	Access	Default	Min.	Max.	Format	Unit
1505	Digital Tune Frequency	AINT32	Get/Set	20 kHz: 19,950	20 kHz: 19,450	20 kHz: 20,450	-	Hz
				30 kHz: 30,000	30 kHz: 29,250	30 kHz: 30,750	-	Hz
				40 kHz: 39,900	40 kHz: 38,900	40 kHz: 40,900	-	Hz



## B.5 Stack Status Class 103 (16 Instances)

The horn status for the horn preset number run. 1625-1694 are for seek, 1725-1794 are for test and 1825-1894 are for scan.

**Table B.9** Stack Status Class (Seek)

Attribute ID	Name	Data Type	Access	Format	Unit
1625*	RTC, Date (DD/MM/YY)	-	-	-	-
1626**	RTC, Time (SS:MM:HH)	-	-	-	-
1630	OL - Overload Group 0 (bit 0-31)	-	-	-	-
1634	CU - Cutoffs Group 1 (bit 0-31)	-	-	-	-
1638	SE - Setup Group 2 (bit 0-31)	-	-	-	-
1642	CM - Cycle Modified Group 3 (bit 0-31)	-	-	-	-
1646	WA - Warnings Group 4 (bit 0-31)	-	-	-	-
1650	LM - Limits Group 5 (bit 0-31)	-	-	-	-
1654	EQ - Equipment Failure Group 6 (bit 0-31)	-	-	-	-
1658	NC - No Cycle Group 7 (bit 0-31)	-	-	-	-
1662	CF - Comm. Failure Group 8 (bit 0-31)	-	-	-	-
1670	HW - Hardware Group A (bit 0-31)	-	-	-	-
1674	NO - No Cycle Overload Group B (bit 0-31)	-	-	-	-
1678	Error Reason	-	-	-	-
1680	Time	AINT32	Get	-	ms
1681	Average Amplitude	AINT32	Get	-	%
1682	Recalled Digital Tune	AINT32	Get	-	Hz
1683	Start Frequency	AINT32	Get	-	Hz
1684	End Frequency	AINT32	Get	-	Hz
1685	Stored Frequency	AINT32	Get	-	Hz
1686	Res. Frequency OK	AINT32	Get	Selection	
1687	End Amplitude Set	AINT32	Get	-	%
1688	End Amplitude	AINT32	Get	-	%
1689	End PSV	AINT32	Get	-	%
1690	End Power	AINT32	Get	-	%
1691	End Current	AINT32	Get	-	%
1692	End Phase	AINT32	Get	-	deg. (°)
1693	End Temperature	AINT32	Get	-	°C
1694	Reserved	AINT32	Get	-	-

**Table B.10** Stack Status Class (Test)

Attribute ID	Name	Data Type	Access	Format	Unit
1725-1778	Same as 1625-1678 for test	-	-	-	-
1780	Time	AINT32	Get	-	ms
1781	Average Amplitude A	AINT32	Get	-	%

**Table B.10** Stack Status Class (Test)

Attribute ID	Name	Data Type	Access	Format	Unit
1782	Average Amplitude B	AINT32	Get	-	%
1783	Recalled Res. Frequency	AINT32	Get	-	Hz
1784	Res. Frequency OK	AINT32	Get	Selection	-
1785	Start Frequency	AINT32	Get	-	Hz
1786	End Frequency	AINT32	Get	-	Hz
1787	End Amplitude Set	AINT32	Get	-	%
1788	End Amplitude	AINT32	Get	-	%
1789	End PSV	AINT32	Get	-	%
1790	End Power	AINT32	Get	-	%
1791	End Current	AINT32	Get	-	%
1792	End Phase	AINT32	Get	-	deg. (°)
1793	End Temperature	AINT32	Get	-	°C
1794	Reserved	AINT32	Get	-	-

\*(Date) It's given in the order: day, month, year - for example 180810

18 Hex = 24 decimal = day

08 Hex = 08 decimal = month

10 Hex = 16 decimal = year

Date = 24/08/16

\*\* (Time) It's given in the order: seconds, minutes, hours - for example 371E0F

37 Hex = 55 decimal = seconds

1E Hex = 30 decimal = minutes

0F Hex = 15 decimal = hours

Time = 15:30:55

**Table B.11** Stack Status Class (Scan)

Attribute ID	Name	Data Type	Access	Format	Unit
1825-1878	Same as 1625-1678 except for scan	-	-	-	-
1880	Time	AINT32	Get	-	ms
1881	Start Frequency	AINT32	Get	-	Hz
1882	End Frequency	AINT32	Get	-	Hz
1883	End Amplitude	AINT32	Get	-	%
1884	End PSV	AINT32	Get	-	%
1885	End Power	AINT32	Get	-	%
1886	End Current	AINT32	Get	-	%
1887	End Phase	AINT32	Get	-	deg. (°)
1888	End Temperature	AINT32	Get	-	°C

## B.5.1 Common Services

**Table B.12** Common Services

Service Code	Service Name
14	Get_Attribute_Single

## B.6 Alarm Data Class 104 (1 Instances)

**Table B.13** Alarm Data Class

Attribute ID	Name	Data Type	Access	Format
200	OL - Overload Group 0 (bit 0-31)	UINT32	Get	OEPB
204	CU - Cutoffs Group 1 (bit 0-31)	UINT32	Get	OEPB
208	SE - Setup Group 2 (bit 0-31)	UINT32	Get	OEPB
212	CM - Cycle Modified Group 3 (bit 0-31)	UINT32	Get	OEPB
216	WA - Warnings Group 4 (bit 0-31)	UINT32	Get	OEPB
220	LM - Limits Group 5 (bit 0-31)	UINT32	Get	OEPB
224	EQ - Equipment Failure Group 6 (bit 0-31)	UINT32	Get	OEPB
228	NC - No Cycle Group 7 (bit 0-31)	UINT32	Get	OEPB
232	CF - Comm. Failure Group 8 (bit 0-31)	UINT32	Get	OEPB
240	HW - Hardware Group A (bit 0-31)	UINT32	Get	OEPB
244	NO - No Cycle Overload Group B (bit 0-31)	UINT32	Get	OEPB
245	Reserved	UINT32	Get	OEPB

### B.6.1 Common Services

**Table B.14** Common Services

Service Code	Service Name
14	Get_Attribute_Single

## B.7 System Information Class 105 (1 Instances)

**Table B.15** System Information Class

Attribute ID	Name	Format
150	PS Frequency	Hz
151	PS Wattage	Watts
154	PS Serial Number	-

### B.7.1 Common Services

**Table B.16** Common Services

Service Code	Service Name
14	Get_Attribute_Single

## B.8 Other Information Class 112 (1 Instances)

**Table B.17** Other Information Class

Attribute ID	Name	Data Type	Access
50	Get Access Token	UINT8	Get
51	Put Access Token	UINT8	Get/Set
100	DCP, HW Version	UINT32	Get
101	DCP, FPGA-Version	UINT32	Get
102	DCP, Bootloader-Version	UINT32	Get
103	DCP, Firmware-Version	UINT32	Get
110	WC, HW Version	UINT32	Get
112	WC, Bootloader-Version	UINT32	Get
113	WC, Firmware-Version	UINT32	Get
170*	RTC, Date (DD/MM/YY)	UINT32	Get/Set
171**	RTC, Time (SS:MM:HH)	UINT32	Get/Set

\*(Date) It's given in the order: day, month, year - for example 180810

18 Hex = 24 decimal = day

08 Hex = 08 decimal = month

10 Hex = 16 decimal = year

Date = 24/08/16

\*\* (Time) It's given in the order: seconds, minutes, hours - for example 371E0F

37 Hex = 55 decimal = seconds

1E Hex = 30 decimal = minutes

0F Hex = 15 decimal = hours

Time = 15:30:55

**Table B.18** System Configuration Parameters

Attribute ID	Name	Data Type	Access
950	Clear Memory Before Seek	UINT32	Get/Set
951	Clear Memory with Reset	UINT32	Get/Set
952	Set digital Tine with Horn Scan	UINT32	Get/Set
953	Clear Memory at Power Up	UINT32	Get/Set

### B.8.1 Common Services

**Table B.19** Common Services

Service Code	Service Name
14	Get_Attribute_Single
16	Set_Attribute_Single

## B.9 Identity Object 1 (1 Instance)

The Identity Class provides identification and general information about the device. The first instance identifies the whole device. It is used for electronic keying and by applications wishing to determine what devices are on the network. The following tables contain the attribute, status, common services, and vendor specific services information for the Identity Object.

**Table B.20** Identity Object (1 - 1 Instance)

Attribute ID	Name	Data Type	Data Value	Access
1	Vendor ID	UINT	1283	Get
2	Product Type	UINT	43	Get
3	Product Code	UINT	2	Get
4	Revision	UINT	1	Get
6	Serial #	AIN		Get
7	Product Name	SHORT STRING32	DCX-FE	Get

### B.9.1 Common Services

**Table B.21** Common Services

Service Code	Service Name
14	Get_Attribute_Single





---

## **Appendix C: Timing Diagrams**

---

C.1      **Timing Diagrams** ..... 222

## C.1 Timing Diagrams

### C.1.1 RF Switching Direct With Feedback, With And Without Alarm

Figure C.1 RF Switching Direct With Feedback, With And Without Alarm

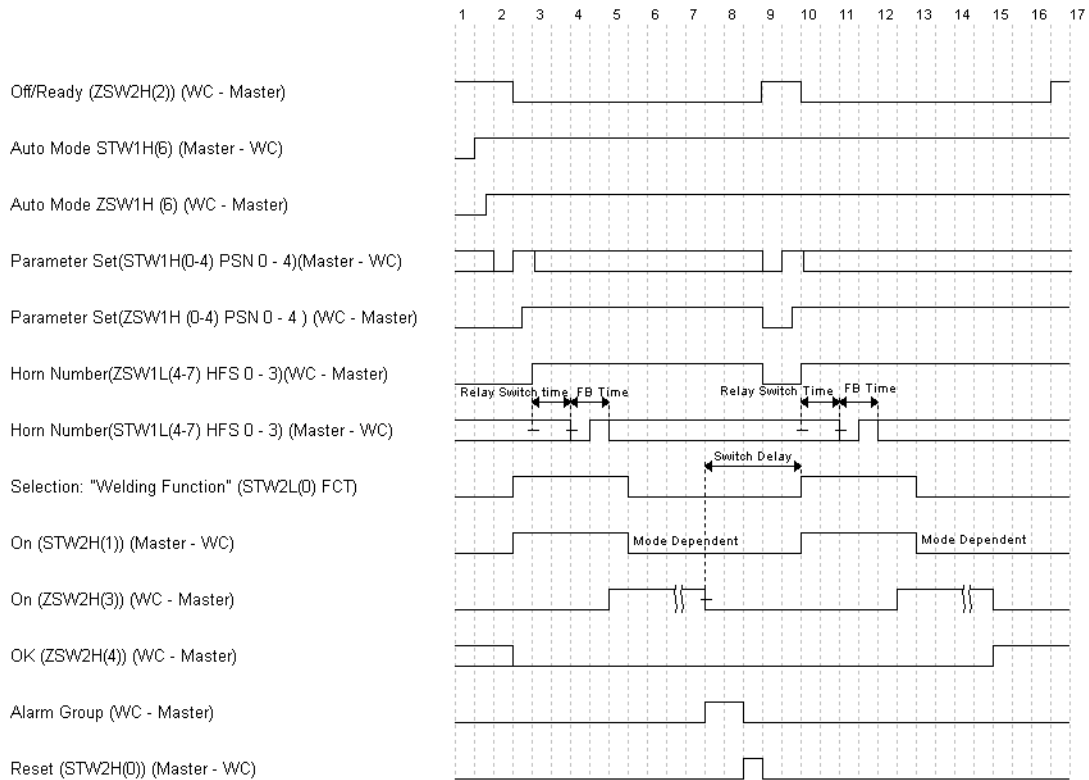

### C.1.2 RF Switching I/O Direct With Feedback, With And Without Alarm

Figure C.2 RF Switching I/O Direct With Feedback, With And Without Alarm

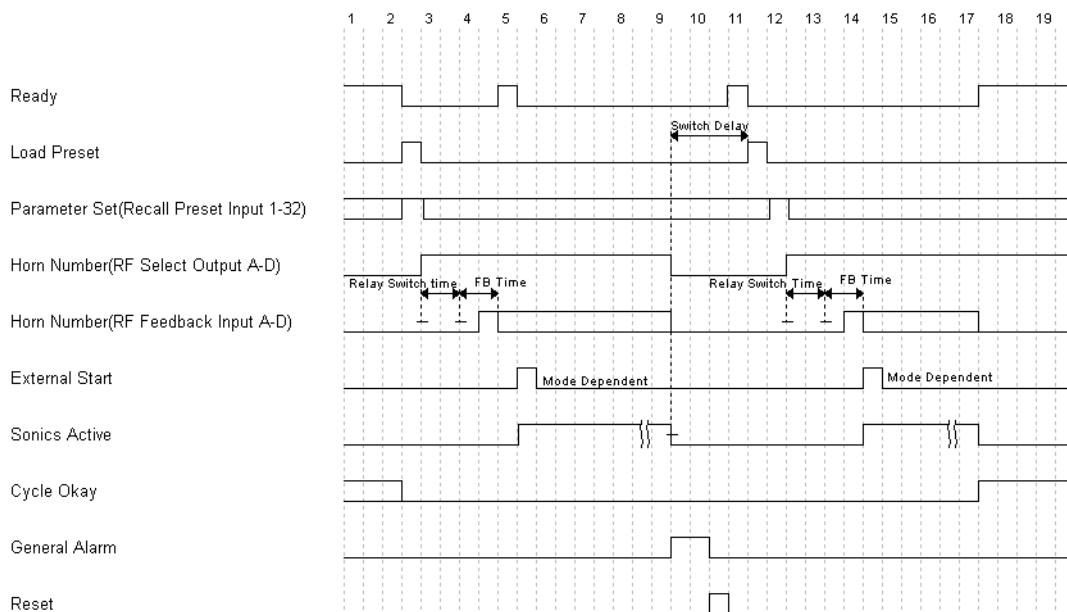

## C.1.3 RF Switching I/O Direct With Feedback With And Without Alarm And Load On Start

Figure C.3 RF Switching I/O Direct With Feedback With And Without Alarm And Load On Start

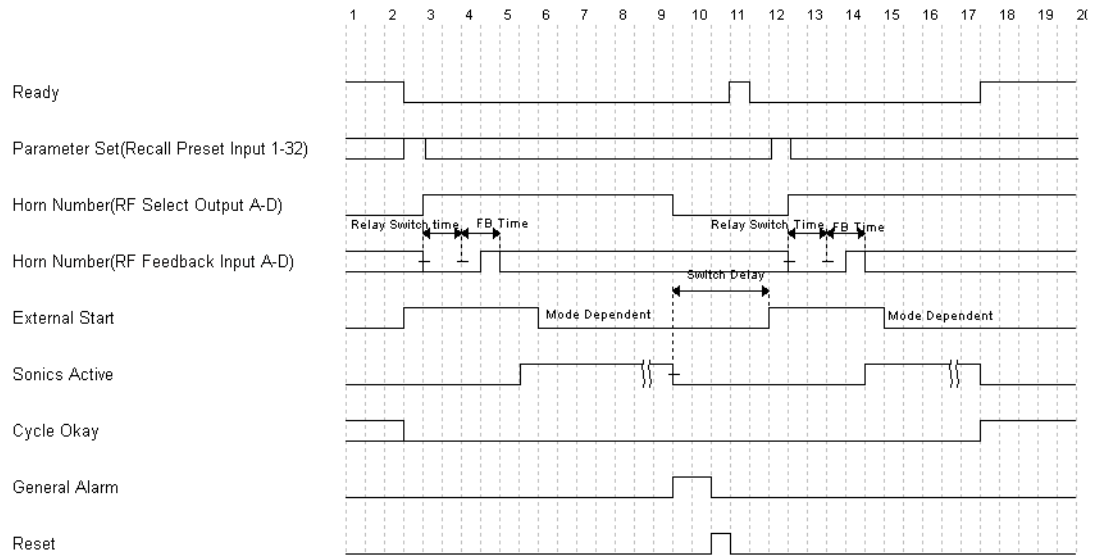

## C.1.4 RF Switching I/O With Off, With And Without Alarm, And Load On Start

Figure C.4 RF Switching I/O With Off, With And Without Alarm, And Load On Start

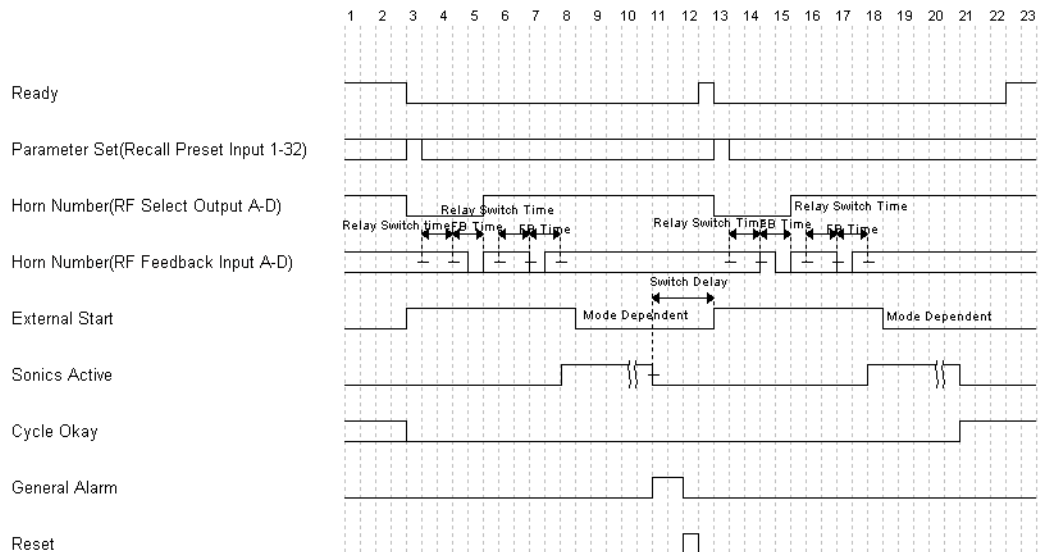

## C.1.5 RF Switching I/O With Off, With Feedback, With And Without Alarm

Figure C.5 RF Switching I/O With Off, With Feedback, With And Without Alarm

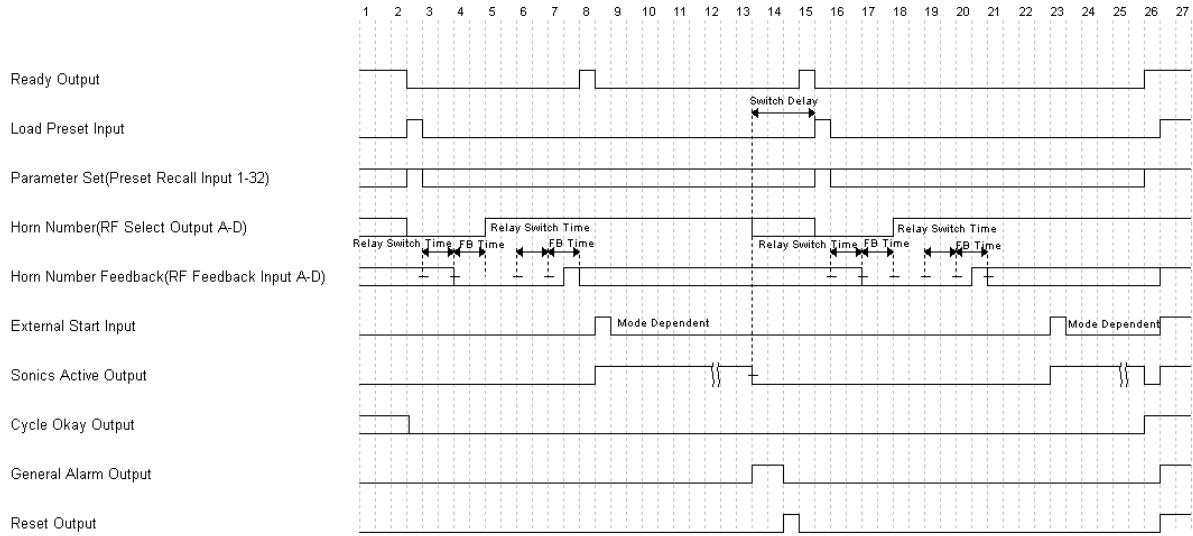

## C.1.6 RF Switching With Off, With Feedback, With And Without Alarm

Figure C.6 RF Switching With Off, With Feedback, With And Without Alarm

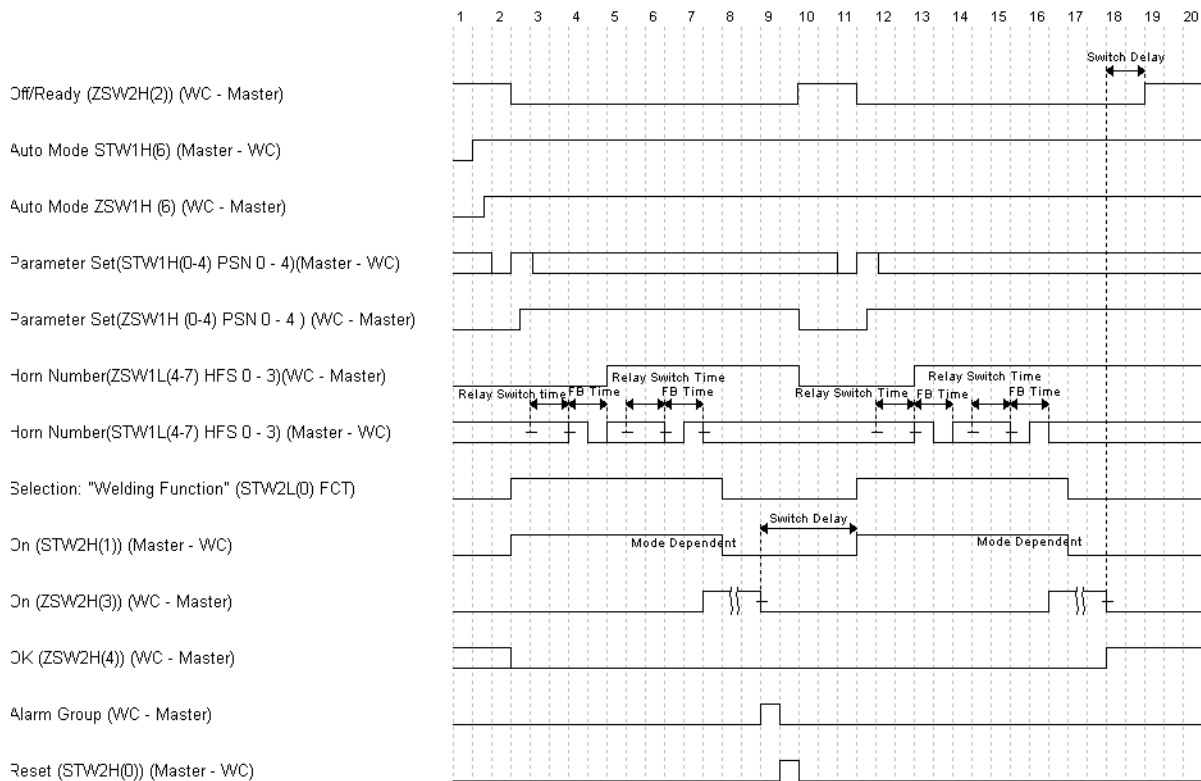

## C.1.7 Timing Diagram For All Other Modes With Actuator

Figure C.7 Timing Diagram For All Other Modes With Actuator

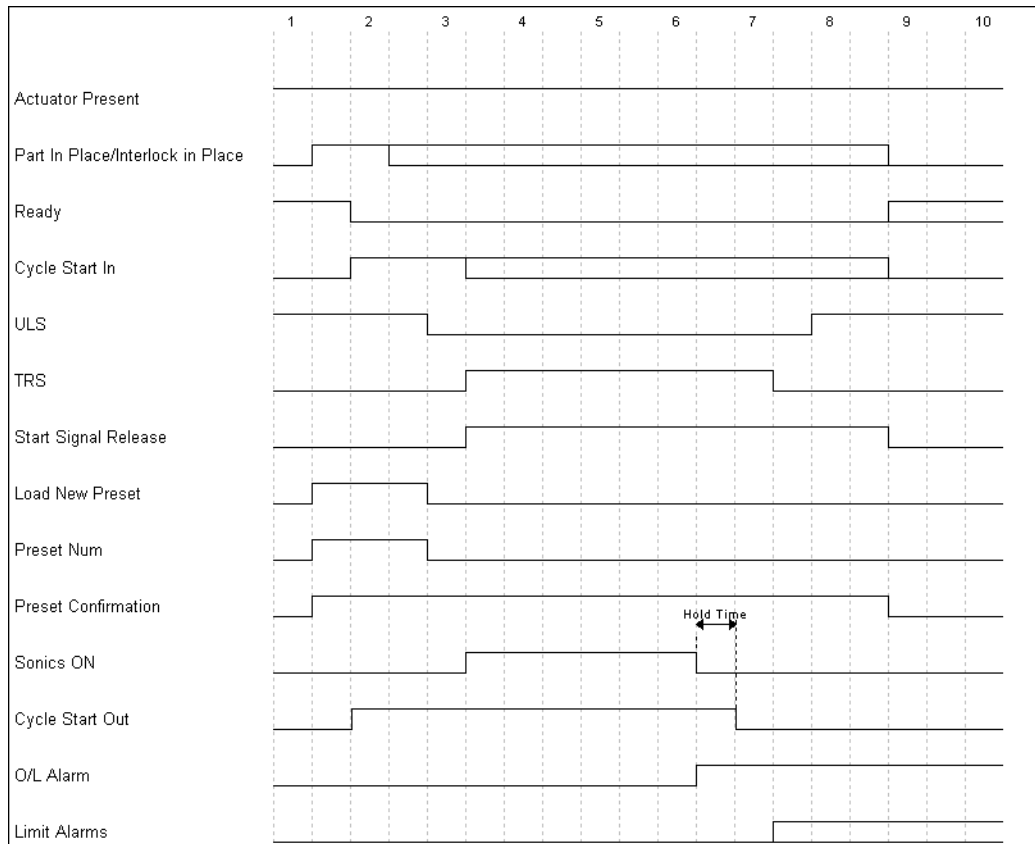

## C.1.8 Timing Diagram For Cycle Abort With Actuator

Figure C.8 Timing Diagram For Cycle Abort With Actuator

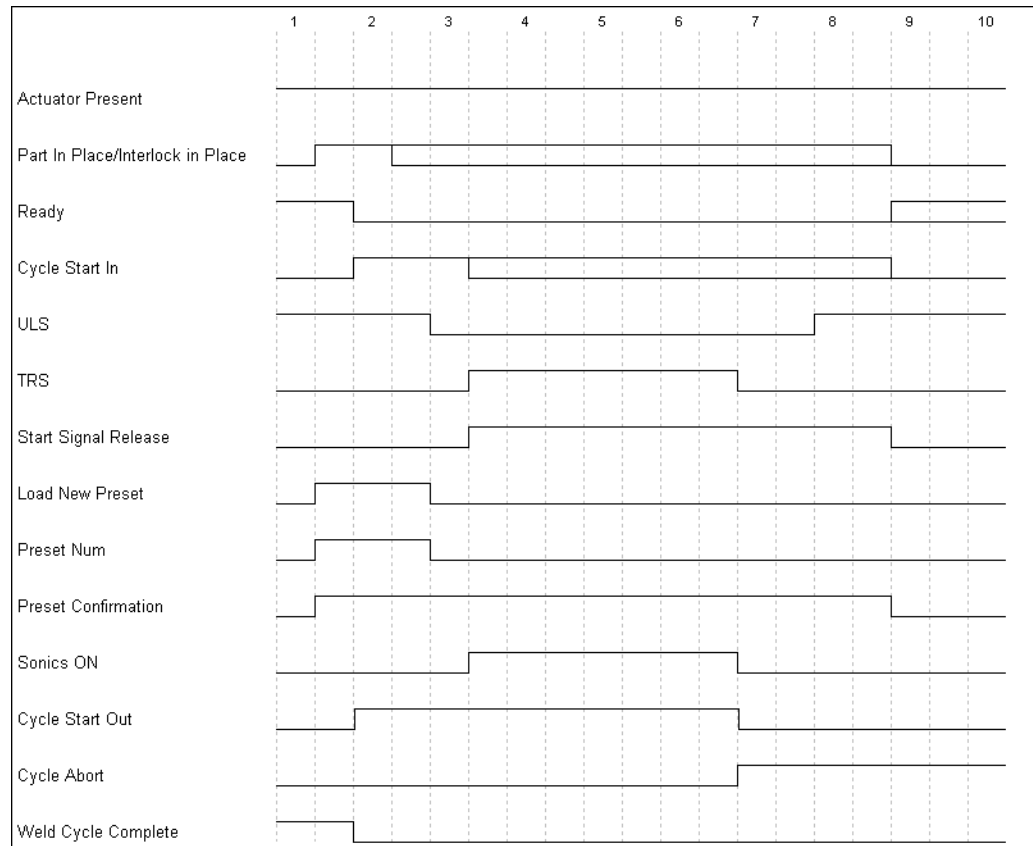

## C.1.9 Timing Diagram For Ground Detect With Actuator

Figure C.9 Timing Diagram For Ground Detect With Actuator

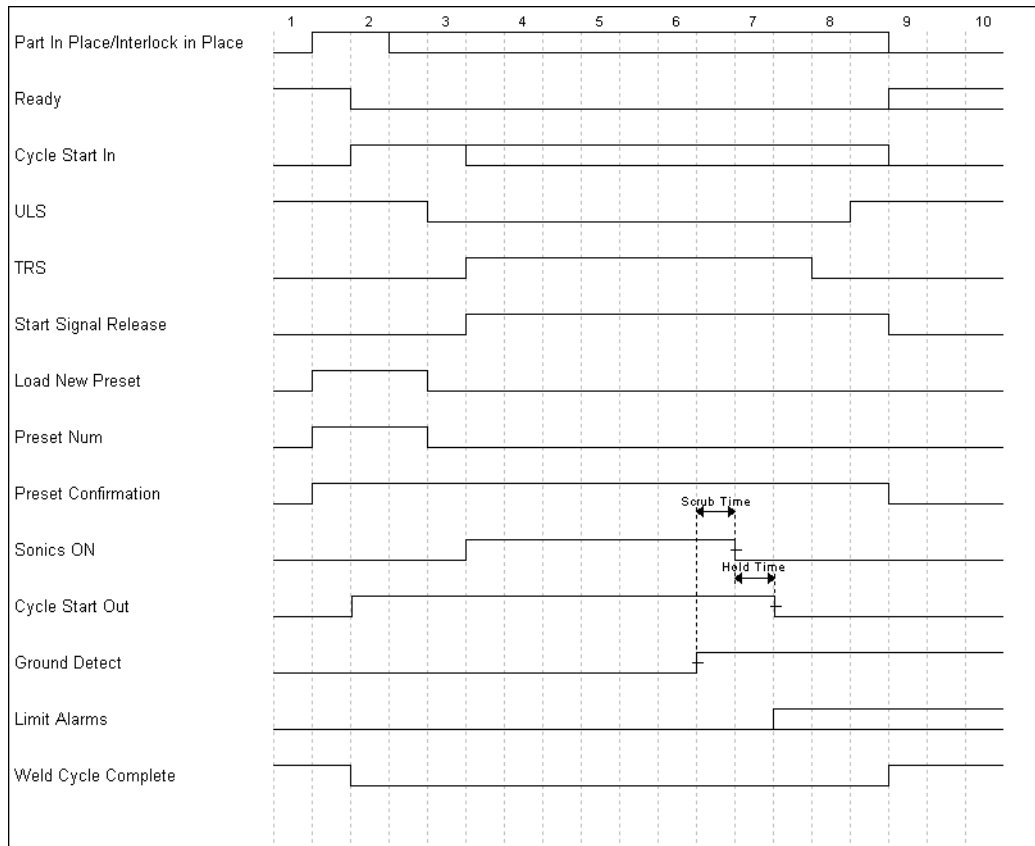





---

## **Appendix D: Signal Diagrams**

---

D.1      Signal Diagrams ..... 230

## D.1 Signal Diagrams

Figure D.1 Continuous Mode

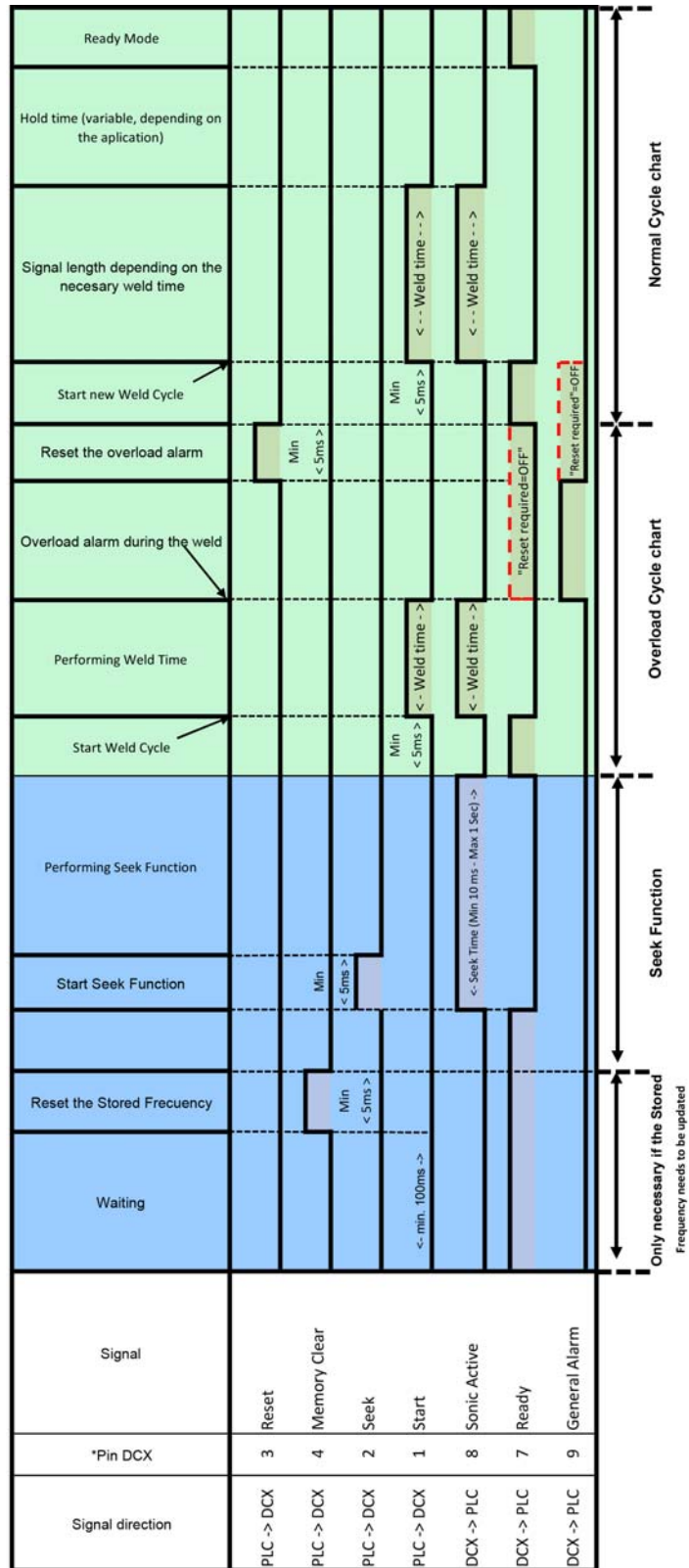

\*Inputs/Outputs are configurable on the User I/O Configuration webpage.

--- If Reset Required is unchecked for Overload in Alarm Webpage interface, Ready signal will be enabled after Start switch is released.

Figure D.2 Time Mode

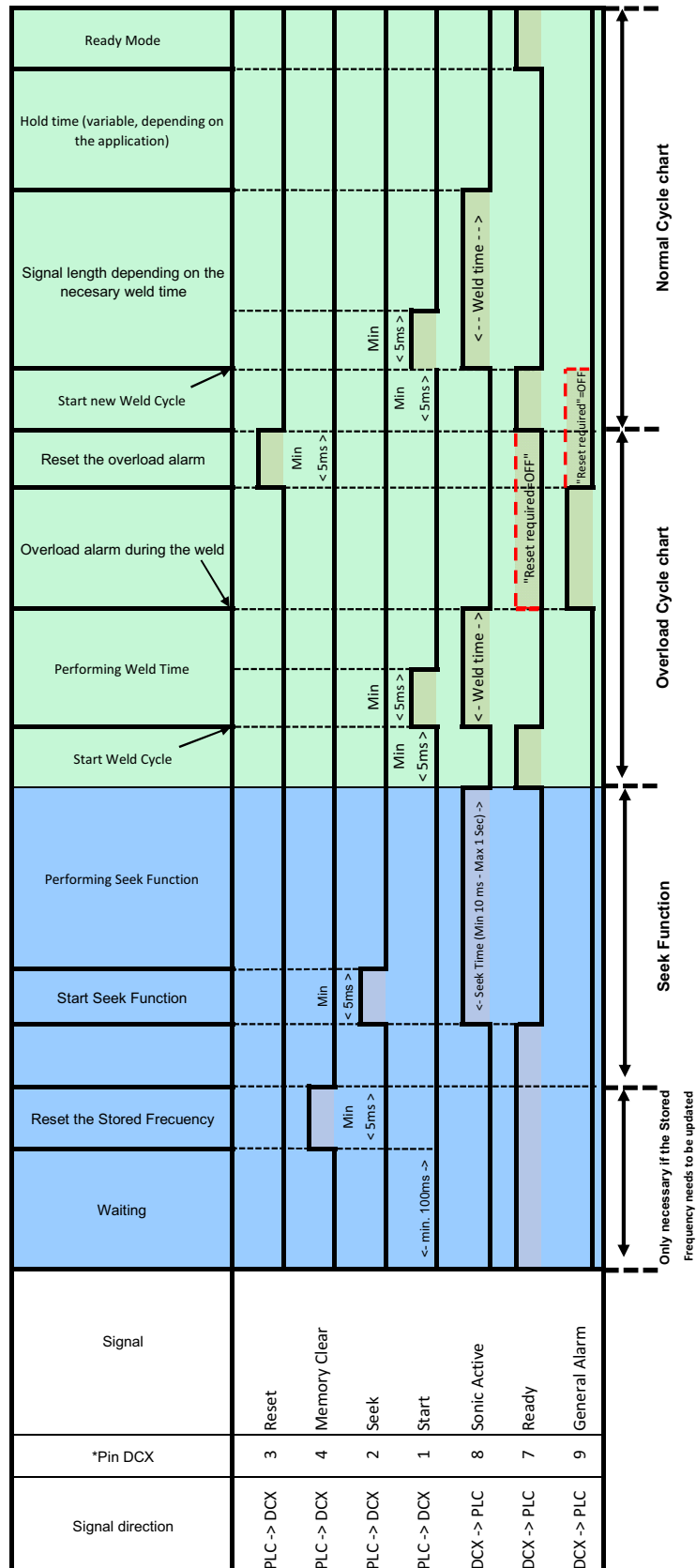

\*Inputs/Outputs are configurable on the User I/O Configuration webpage.

--- If Reset Required is unchecked for Overload in Alarm Webpage interface, Ready signal will be enabled when General Alarm becomes active.

Figure D.3 AE Actuator

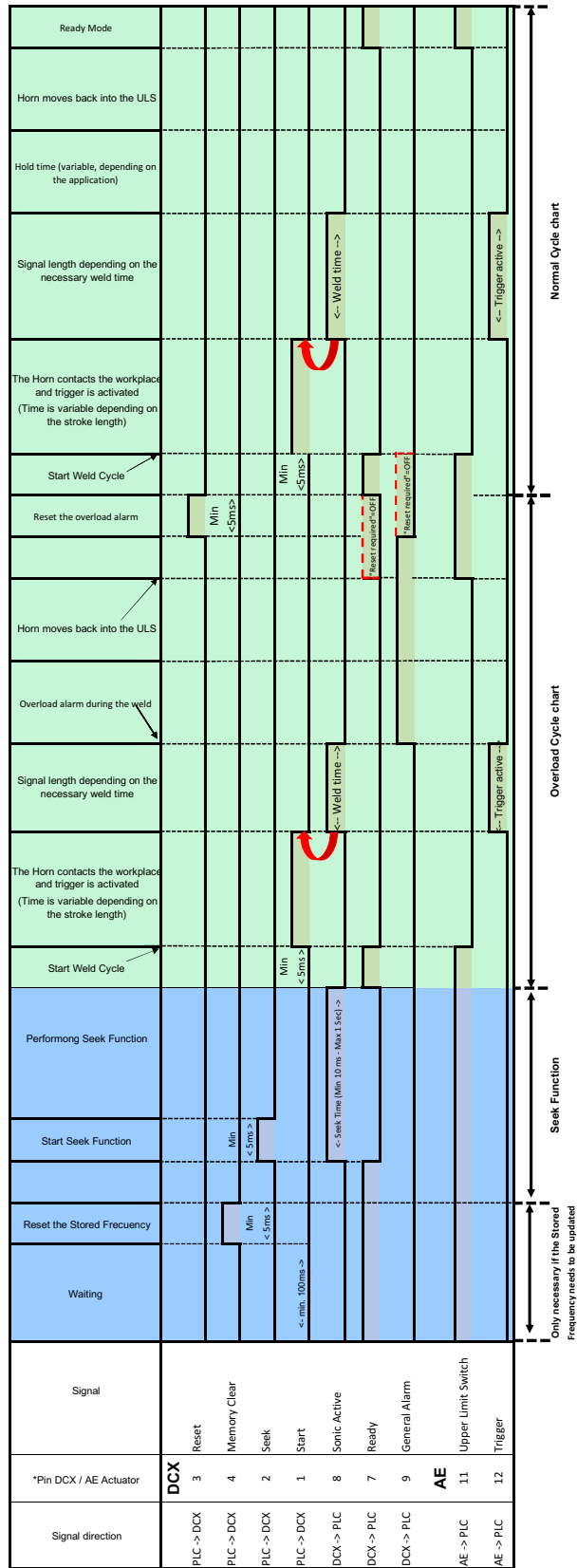

\*Inputs/Outputs are configurable on the User I/O Configuration webpage.

Start signal should be released by Sonic Active

--- If Reset Required is unchecked for Overload in Alarm Webpage interface, Ready signal will be enabled when Upper Limit Switch becomes active.

---

# Index

---

## Numerics

24 V Indicator 21

## A

Acoustic Stack 75  
Actuator 18, 27  
Afterburst 74  
Alarm 27  
Alarm Data 216  
Alarm Icon 24  
Alarm Reset Key 20  
Alarms 111, 189  
Amplitude 27, 109  
Amplitude Control 27  
Analog Input Functions 64  
Analog Output Functions 65  
Autotuning 17

## B

Booster 18, 27, 95  
Boosters 179  
Branson  
    how to contact 8

## C

Cables 33  
Circle Icon 24  
Circuit Breaker / Power Switch 25  
Clamping Force 27  
Cold Start 27, 187  
Communication Failure Alarms 200  
Compatibility 16  
Configuration Key 20  
Connections 25  
Continuous 98  
Continuous Mode 99  
Continuous Mode Icon 22  
Control Word (STW1) 135  
Control Word (STW2) 138  
Controls and Indicators 20  
Converter 18, 27, 95  
Converter Cooling 80  
Converters 178  
Converters and Boosters 85  
Counters 27  
Cutoff Alarms 192  
Cutoffs 74  
Cycle Modified Alarms 194

## D

- DCX Inputs/PLC Outputs 144
- DCX Outputs/PLC Inputs 139
- Declaration of Conformity 40
- Degating 27
- Delivery 31
- Delivery and Handling 29
- Digital Amplitude Setting 17
- Digital Input Functions 60
- Digital Output Functions 62
- Drop Test 30

## E

- Electrical Connections 54
- Electrical Problems 184
- Electrical Specifications 36
- Emissions 6
- End of Weld Store 74
- Energy 98
- Energy Brake 74
- Energy Director 27
- Energy Mode 103
- Energy Mode Icon 22
- Environmental Requirements 50
- Environmental Specifications 30, 36
- Equipment Failure Alarms 197
- Ethernet Port 21, 25
- EtherNet/IP 17, 27, 124
- EtherNet/IP Commands 205
- EtherNet/IP Connectors 21
- EtherNet/IP Operation 123
- EtherNet/IP Overview 127
- EtherNet/IP Specifications 126
- EtherNet/IP Status Indicator 21
- Explicit Message 128
- External Amplitude Control 27, 110
- External Frequency Control 27

## F

- Features 17
- Fieldbus 27
- Fixture 27
- Flash 27
- Forming 27
- Frequency 27
- Frequency Offset 17, 27, 74
- Fretting Corrosion 27
- Front Panel 20

## G

- Gain 27
- General Maintenance 168
- General Precautions 4
- Glossary 27
- Ground Detect 98
- Ground Detect Icon 23

Ground Detect Mode 107  
Ground Screw 25

## H

Hardware Alarms 201  
Horizontal (Benchtop) Mounting 52  
Horn 19, 27, 95  
Horn Amplitude 27  
Horn Signature 17, 27  
how to contact Branson 8  
Humidity 30

## I

I/O Connections 122  
Identity Object 219  
Implicit (I/O) Message 128  
Implicit Message for Reset 145  
Implicit Message for Run 144  
Implicit Message for Scan 145  
Implicit Message for Seek 144  
Implicit Messaging 133  
Input Power Connection 72  
Insertion 27  
Installation and Setup 43  
Installation Requirements 45  
Installation Steps 51  
Intended Use of the System 6  
Interface 27  
Introduction 13  
Inventory 33

## J

Joint 27  
Joule Icon 23

## L

LCD 17, 20  
LCD Bar-Graph 117  
LED Status Indicator 124  
Limit Alarms 196  
Limits 74  
Line Input Connector 25  
Line Regulation 17  
Load Regulation 17  
Location 45

## M

Maintenance 167  
Membrane Keys 17  
Mode 74  
Mount the Power Supply 52  
Mounting Considerations 53

## N

No Cycle Alarms 199

Non-Cycle Overload Alarms 202  
Number Sign Icon 23  
Numeric Display 22

## O

Operation 97  
Other Information 218  
Other Items 181  
Output Power 71  
Overload Alarms 190  
Overview 15

## P

Parameter 27  
Parameter Range 27  
Parameter Set Object 206  
Passcodes 17  
Peak Power 98  
Peak Power Icon 23  
Peak Power Mode 105  
Percentage Icon 23  
Physical Description 39  
Pneumatic Requirements 50  
Power Supply 28  
Power Up 74  
Power/Frequency Bar-Graph 24  
Power-On Indicator 21  
Preventive Maintenance 170  
Primary Parameters 98

## R

Ramp Starting 17  
Receiving 31  
Recondition the Stack 171  
Registers 112, 114  
Regulatory Compliance 6  
Returning Equipment 34  
RF Connector 25

## S

Safety and Support 1  
Safety Requirements 2  
Seek 17, 28  
Seek Ramp 74  
Seek Time 74  
Setup 74  
Setup Alarms 193  
Shipping and Handling 30  
Shock / Vibration (transit) 30  
Solid Mount Boosters 96  
Sonics Active Indicator 23  
Spare Stock 176  
Stack Function 144  
Stack Parameter Object 211  
Stack Status Object 213



- Stack Torque Values 173
- Staking 28
- Start Ramp 74
- Start-up Diagnostics 17
- Status Word (ZSW1) 140
- Status Word (ZSW2) 143
- Storage / Shipping Temperature 30
- STW1 135
- STW2 138
- Suggested Spares 177
- Swaging 28
- Symbols 2
- System Cables 176
- System Information 217
- System Protection 17

## T

- Technical Specifications 35
- Test Procedure 120
- Thermoplastic 28
- Thermoset 28
- Time 98
- Time Icon 23
- Time Mode 101
- Time Mode Icon 22
- Timed Seek 18, 74
- Timing Diagrams 221
- Token 28
- Troubleshooting 183
- True Wattmeter 18

## U

- Ultrasonic Power 28
- Ultrasonic Power Problems 185
- Ultrasonic Stack 95
- Ultrasonic Welding 28
- Ultrasonics Test Key 21
- Unpacking 32
- Up/Down Keys 20
- User I/O Cable Pin Assignments 58
- User I/O Connections 56
- User I/O Connector 25
- User ID 17, 28

## V

- Vertical Mounting 52

## W

- Warning Alarms 195
- Warnings 2
- Web Page Interface 18
- Weld Amplitude 74
- Weld Cycle Problems 186
- Weld Data Object 209
- Weld System 28

Welding System 17  
Wiring Considerations 45

## **Z**

ZSW1 140  
ZSW2 143