



EMERSON[™]

Original Instructions
4000848 - REV. 01



DCX F-DP

Power Supply

Operating Manual

Branson Ultrasonics Corp.
120 Park Ridge Road
Brookfield, CT 06804
(203) 796-0400
<http://www.bransonultrasonics.com>

BRANSON

Manual Change Information

At Branson, we strive to maintain our position as the leader in ultrasonics plastics joining, metal welding, cleaning and related technologies by continually improving our circuits and components in our equipment. These improvements are incorporated as soon as they are developed and thoroughly tested.

Information concerning any improvements will be added to the appropriate technical documentation at its next revision and printing. Therefore, when requesting service assistance for specific units, note the Revision information found on this document, and refer to the printing date which appears on this page.

Copyright and Trademark Notice

Copyright © 2022 Branson Ultrasonics Corporation. All rights reserved. Contents of this publication may not be reproduced in any form without the written permission of Branson Ultrasonics Corporation.

Mylar is a registered trademark of DuPont Teijin Films.

Loctite is a registered trademark of Loctite Corporation.

WD-40 is a registered trademark of WD-40 Company.

Windows 7, Windows Vista, and Windows XP are registered trademarks of Microsoft Corporation

Other trademarks and service marks mentioned herein are held by their respective owners.

Foreword

Congratulations on your choice of a Branson Ultrasonics Corporation system!

The Branson DCX Power Supply F-DP system is process equipment for the joining of plastic parts using ultrasonic energy. It is the newest generation of product using this sophisticated technology for a variety of customer applications. This Operating Manual is part of the documentation set for this system, and should be kept with the equipment.

Thank you for choosing Branson!

Introduction

This manual is arranged into several structured chapters which will help you find the information you may need to know to safely handle, install, set up, program, operate, and/or maintain this product. Please refer to the [Table Of Contents](#) and/or the [Index](#) of this manual to find the information you may be looking for. In the event you require additional assistance or information, please contact our Product Support department (see [1.4 How to Contact Branson](#) for information on how to contact them) or your local Branson representative.



Table Of Contents

Chapter 1: Safety and Support

1.1	Safety Requirements and Warnings	2
1.2	General Precautions	4
1.3	Warranty	6
1.4	How to Contact Branson	7
1.5	Returning Equipment for Repair	8
1.6	Obtaining Replacement Parts	11

Chapter 2: Introduction

2.1	Models Covered	14
2.2	Compatibility with other Branson Products	16
2.3	Features	17
2.4	Controls and Indicators	19
2.5	Welding Systems	25
2.6	Glossary	26

Chapter 3: Delivery and Handling

3.1	Shipping and Handling	30
3.2	Receiving	31
3.3	Unpacking the Power Supply	32
3.4	Take Inventory of Small Parts	33
3.5	Returning Equipment	34

Chapter 4: Technical Specifications

4.1	Technical Specifications	36
4.2	Physical Description	38
4.3	Declaration of Conformity	39
4.4	PROFIBUS Certificate	41

Chapter 5: Installation and Setup

5.1	About Installation	46
5.2	Installation Requirements	47
5.3	Installation Steps	53
5.4	Electrical Connections	56
5.5	Power Supply Setup	72
5.6	Assembling the Acoustic Stack	73
5.7	Converter Cooling	78
5.8	Testing the Installation	80
5.9	Still Need Help?	81

Chapter 6: Converters and Boosters

6.1	Converters and Boosters	84
-----	-----------------------------------	----

Chapter 7: Operation

7.1	Setting Primary Parameters	96
7.2	Setting the Amplitude	107
7.3	Resetting the Power Supply Alarms	109
7.4	Configuring the Power Supply Registers	110
7.5	LCD Bar-Graph	114

7.6	Ultrasonics Test Procedure	117
7.7	Using the I/O Connections	119

Chapter 8: PROFIBUS DP Operation

8.1	PROFIBUS DP	122
8.2	Configuration	125
8.3	Implicit Messaging	134

Chapter 9: Maintenance

9.1	General Maintenance Considerations	148
9.2	DCX Power Supply F-DP Preventive Maintenance	150
9.3	Recommended Spare Stock	155
9.4	Circuit Diagram	160
9.5	Troubleshooting	161
9.6	Cold Start Procedure	164

Appendix A: Alarms

A.1	Overload Alarms (Group 0)	166
A.2	Cutoff Alarms (Group 1)	168
A.3	Setup Alarms (Group 2)	169
A.4	Cycle Modified Alarms (Group 3)	170
A.5	Warning Alarms (Group 4)	171
A.6	Limit Alarms (Group 5)	172
A.7	Equipment Failure Alarms (Group 6)	173
A.8	No Cycle Alarms (Group 7)	175
A.9	Communication Failure Alarms (Group 8)	176
A.10	Hardware Alarms (Group A)	177
A.11	Non-Cycle Overload Alarms (Group B)	178

Appendix B: Communication Channel Commands

B.1	Weld Parameters	182
B.2	Seek Stack Parameters	186
B.3	Test Stack Parameters	187
B.4	Common Stack Parameters	188
B.5	Alarm Commands	189
B.6	Weld Parameter Status	190
B.7	Weld Status Commands	192
B.8	Seek Parameter Status	193
B.9	Seek Stack Commands	194
B.10	Test Parameter Status	195
B.11	Test Stack Commands	196
B.12	Scan Parameter Status	197
B.13	Scan Stack Commands	198
B.14	Process Data Channels	199
B.15	Communication Channel	200
B.16	Token Access	201
B.17	Version, System, & RTC Information	202
B.18	System Configuration Parameters	203

Appendix C: Timing Diagrams

C.1	Timing Diagrams	206
-----	---------------------------	-----

Appendix D: Signal Diagrams

D.1	Signal Diagrams	214
-----	---------------------------	-----

List Of Figures

Chapter 1: Safety and Support

Figure 1.1	Safety-related Labels found on the DCX Power Supply F-DP	3
------------	--	---

Chapter 2: Introduction

Figure 2.1	The DCX Power Supply F-DP (Horizontal)	14
Figure 2.2	The DCX Power Supply F-DP (Vertical)	15
Figure 2.3	DCX Power Supply F-DP Front Panel Controls and Indicators	19
Figure 2.4	LCD Description	21
Figure 2.5	DCX Power Supply F-DP Back Panel (Horizontal)	24
Figure 2.6	DCX Power Supply F-DP Bottom Panel (Vertical)	24

Chapter 3: Delivery and Handling

Chapter 4: Technical Specifications

Figure 4.1	EU Declaration of Conformity	39
Figure 4.2	UK Declaration of Conformity	40
Figure 4.3	PROFIBUS Certificate	41
Figure 4.4	Association Trademark	42
Figure 4.5	Technology Trademarks	42
Figure 4.6	Certification Trademark	42
Figure 4.7	Certified by PI Trademark	42

Chapter 5: Installation and Setup

Figure 5.1	DCX Power Supply F-DP Benchtop Dimensional Drawing	48
Figure 5.2	DCX Power Supply F-DP Vertical Mount Dimensional Drawing (400 W, 750 W and 800 W)	49
Figure 5.3	DCX Power Supply F-DP Vertical Mount Dimensional Drawing (1.25 kW and 1.5 kW)	50
Figure 5.4	DCX Power Supply F-DP Vertical Mount Dimensional Drawing (2.5 kW and 4 kW)	51
Figure 5.5	LCD Viewing Angle	55
Figure 5.6	DCX Power Supply F-DP Connections (Horizontal Model)	56
Figure 5.7	DCX Power Supply F-DP Connections (Vertical Model)	57
Figure 5.8	User I/O Cable Identification and Wire Color Diagram	59
Figure 5.9	Typical Digital I/O Wiring Examples	68
Figure 5.10	Typical Analog I/O Wiring Examples	69
Figure 5.11	RF Cable Connection	70
Figure 5.12	Assembling the Acoustic Stack	74
Figure 5.13	Connecting Tip to Horn	77

Chapter 6: Converters and Boosters

Figure 6.1	20 kHz typical Converter Dimensions	84
Figure 6.2	20 kHz Booster Dimensions	85
Figure 6.3	20 kHz Converter/Booster/Horn, Typical Dimensions	86
Figure 6.4	30 kHz Converter Dimensions	87
Figure 6.5	30 kHz Booster Dimensions	88
Figure 6.6	30 kHz Converter/Booster/Horn, Typical Dimensions	89
Figure 6.7	40 kHz, 4TR Converter Dimensions	90
Figure 6.8	40 kHz Booster Dimensions	91
Figure 6.9	40 kHz Converter/Booster/Horn, Typical Dimensions	92

Chapter 7: Operation

Figure 7.1	LCD at Power Up	107
Figure 7.2	LCD when in External Amplitude Control Mode	108
Figure 7.3	Test Connections	119

Chapter 8: PROFIBUS DP Operation

Figure 8.1	LED Status Indicator	122
Figure 8.2	Writing and reading Parameters	131

Chapter 9: Maintenance

Figure 9.1	Reconditioning Stack Mating Surfaces	152
Figure 9.2	Interconnect Diagram, Power Supply	160

Appendix A: Alarms

Appendix B: Communication Channel Commands

Appendix C: Timing Diagrams

Figure C.1	RF Switching Direct With Feedback, With And Without Alarm	206
Figure C.2	RF Switching I/O Direct With Feedback, With And Without Alarm	206
Figure C.3	RF Switching I/O Direct With Feedback, With And Without Alarm, And Load On Start	207
Figure C.4	RF Switching I/O With Off, With And Without Alarm, And Load On Start	207
Figure C.5	RF Switching I/O With Off, With Feedback, With And Without Alarm	208
Figure C.6	RF Switching With Off, With Feedback, With And Without Alarm	208
Figure C.7	Timing Diagram For All Other Modes With Actuator	209
Figure C.8	Timing Diagram For Cycle Abort With Actuator	210
Figure C.9	Timing Diagram For Ground Detect With Actuator	211

Appendix D: Signal Diagrams

Figure D.1	Continuous Mode	214
Figure D.2	Time Mode	215
Figure D.3	AE Actuator	216

List Of Tables

Chapter 1: Safety and Support

Table 1.1	Branson Contacts	9
-----------	------------------	---

Chapter 2: Introduction

Table 2.1	Models Covered in this Manual	14
Table 2.2	Power Supply Compatibility with Branson Converters	16
Table 2.3	DCX Power Supply F-DP Front Panel Controls and Indicators	19
Table 2.4	LCD Description	21
Table 2.5	Connections to the DCX Power Supply F-DP	24

Chapter 3: Delivery and Handling

Table 3.1	Shipping Specifications	30
Table 3.2	Inspect the Power Supply	31
Table 3.3	Unpacking the Power Supply	32
Table 3.4	Small Parts included: Power Supply Assemblies	33
Table 3.5	DCX Power Supply F-DP System Cables	33

Chapter 4: Technical Specifications

Table 4.1	Environmental Specifications	36
Table 4.2	Electrical Input Operating Voltages	36
Table 4.3	Input Current and Circuit Breaker Specifications	37
Table 4.4	Continuous Duty Maximum Power	37
Table 4.5	Dimension and Weight of DCX Power Supply F-DP	38

Chapter 5: Installation and Setup

Table 5.1	DCX Power Supply F-DP Benchtop Dimensional Drawing	48
Table 5.2	DCX Power Supply F-DP Vertical Mount Dimensional Drawing (400 W, 750 W and 800 W)	49
Table 5.3	DCX Power Supply F-DP Vertical Mount Dimensional Drawing (1.25 kW and 1.5 kW)	50
Table 5.4	DCX Power Supply F-DP Vertical Mount Dimensional Drawing (2.5 kW and 4 kW)	51
Table 5.5	Environmental Requirements	52
Table 5.6	Input Current and Circuit Breaker Specifications	52
Table 5.7	DCX Power Supply F-DP Connections (Horizontal Model)	56
Table 5.8	DCX Power Supply F-DP Connections (Vertical Model)	57
Table 5.9	User I/O Cable Identification and Wire Color Diagram	59
Table 5.10	User I/O Cable Pin Assignments	60
Table 5.11	Digital Input Functions	61
Table 5.12	Digital Output Functions	63
Table 5.13	Analog Input Functions	64
Table 5.14	Analog Output Functions	65
Table 5.15	Default Branson User I/O Connector PIN Assignments, V6.0	66
Table 5.16	Default Branson User I/O Connector PIN Assignments, V6.5	67
Table 5.17	RF Cable Connection	70
Table 5.18	Input Power Connection	71
Table 5.19	Acoustic Stack Description	74
Table 5.20	Stack Torque Values	75
Table 5.21	Tools	75
Table 5.22	20 kHz System	75
Table 5.23	30 kHz System	76

Table 5.24	40 kHz System	76
Table 5.25	Tip to horn torque values.	77
Table 5.26	Continuous Duty Max. Power & Full Power Duty Cycle	78
Table 5.27	Converter Cooling Procedure	78

Chapter 6: Converters and Boosters

Table 6.1	20 kHz Converter	84
Table 6.2	20 kHz Booster.	85
Table 6.3	20 kHz Converter/Booster/Horn	86
Table 6.4	30 kHz Converter	87
Table 6.5	30 kHz Booster.	88
Table 6.6	30 kHz Converter/Booster/Horn	89
Table 6.7	40 kHz, 4TR Converter	90
Table 6.8	40 kHz Booster.	91
Table 6.9	40 kHz Converter/Booster/Horn	92

Chapter 7: Operation

Table 7.1	Summary of Weld Modes	96
Table 7.2	Continuous Mode Operational Sequence	97
Table 7.3	Time Mode Parameters	98
Table 7.4	Selecting Time Mode	99
Table 7.5	Setting Time Mode Parameters.	100
Table 7.6	Energy Mode Parameters.	100
Table 7.7	Selecting Energy Mode	100
Table 7.8	Setting Energy Mode Parameters	101
Table 7.9	Peak Power Mode Parameters	103
Table 7.10	Selecting Peak Power Mode	103
Table 7.11	Setting Peak Power Mode Parameters	104
Table 7.12	Ground Detect Mode Parameters	105
Table 7.13	Selecting Ground Detect Mode	105
Table 7.14	Setting Ground Detect Mode Parameters	106
Table 7.15	Setting the Amplitude Using the Front Panel Controls	107
Table 7.16	Resetting the DCX Power Supply F-DP.	109
Table 7.17	Steps to Configure the Power Supply Registers	110
Table 7.18	Power Supply Registers	111
Table 7.19	Power Bar-Graph Interpretation Examples	114
Table 7.20	Frequency Bar-Graph Interpretation - 20 kHz (50 Hz Segment)	115
Table 7.21	Frequency Bar-Graph Interpretation - 30 kHz (76 Hz Segment)	115
Table 7.22	Frequency Bar-Graph Interpretation - 40 kHz (100 Hz/Segment)	116
Table 7.23	Frequency Bar-Graph Interpretation Examples.	116
Table 7.24	Power Supply Ultrasonic Test Procedure (Front Panel).	117
Table 7.25	Power Supply Ultrasonic Test Procedure (User I/O).	119

Chapter 8: PROFIBUS DP Operation

Table 8.1	DCX Power Supply F-DP LED Status Indicator	122
Table 8.2	Data Bandwidth Demands on PROFIBUS Communications Systems	123
Table 8.3	Pin-out Listing for the PROFIBUS Bus Plug Connector	123
Table 8.4	Line Types	124
Table 8.5	User Parameters.	125
Table 8.6	Communication Channel (PKW)	126
Table 8.7	Subdivisions of the communication channel (PKW)	127
Table 8.8	Identifier (PKE) of the communication channel (PKW)	127
Table 8.9	Answer code - Master > Slave	127
Table 8.10	IND (High Byte)	128
Table 8.11	Answer Code: Slave > Master	128
Table 8.12	Error Number PKE, Low Byte	129
Table 8.13	DCX Inputs/PLC Outputs (8 bytes)	134

Table 8.14	Control Word (STW1)	135
Table 8.15	HFS Bit (Control Word)	136
Table 8.16	PSN Bit (Control Word)	136
Table 8.17	Control Word (STW2)	138
Table 8.18	DCX Outputs/PLC Inputs (20 bytes)	139
Table 8.19	Status Word (ZSW1)	140
Table 8.20	HFS Bit (Status Word)	141
Table 8.21	PSN Bit (Status Word)	141
Table 8.22	Status Word (ZSW2)	143
Table 8.23	Stack Function	143
Table 8.24	Implicit Message for Run	144
Table 8.25	Implicit Message for Seek	144
Table 8.26	Implicit Message for Scan	144
Table 8.27	Implicit Message for Reset	145

Chapter 9: Maintenance

Table 9.1	Stack Reconditioning Procedure	151
Table 9.2	Reconditioning Stack Mating Surfaces	152
Table 9.3	Stack Torque Values	152
Table 9.4	Stack Reassembly for a 20 kHz System	153
Table 9.5	Stack Reassembly for a 30 kHz System	153
Table 9.6	Stack Reassembly for a 40 kHz System	154
Table 9.7	Stud Torque Values	154
Table 9.8	DCX Power Supply F-DP System Cables	155
Table 9.9	Suggested Spares	155
Table 9.10	Converters Compatible with the DCX Power Supply F-DP	156
Table 9.11	DCX Power Supply F-DP Compatible Boosters	157
Table 9.12	Other Items used with the DCX Power Supply F-DP	158
Table 9.13	Troubleshooting	161
Table 9.14	Troubleshooting Common Electrical Problems	161
Table 9.15	Troubleshooting Ultrasonic Power Problems	162
Table 9.16	Troubleshooting Weld Cycle Problems	163
Table 9.17	Steps to Perform a Cold Start	164

Appendix A: Alarms

Table A.1	Overload Alarms (Group 0)	166
Table A.2	Cutoff Alarms (Group 1)	168
Table A.3	Cycle Modified Alarms (Group 2)	169
Table A.4	Cycle Modified Alarms (Group 3)	170
Table A.5	Warning Alarms (Group 4)	171
Table A.6	Limit Alarms (Group 5)	172
Table A.7	Equipment Failure Alarms (Group 6)	173
Table A.8	No Cycle Alarms (Group 7)	175
Table A.9	Communication Failure Alarms (Group 8)	176
Table A.10	Hardware Alarms (Group A)	177
Table A.11	Non-Cycle Overload Alarms (Group B)	178

Appendix B: Communication Channel Commands

Table B.1	Weld Parameters	182
Table B.2	Seek Stack Parameters	186
Table B.3	Test Stack Parameters	187
Table B.4	Common Stack Parameters	188
Table B.5	Alarm Commands	189
Table B.6	Weld Parameter Status	190
Table B.7	Weld Status Commands	192
Table B.8	Seek Parameter Status	193
Table B.9	Seek Stack Commands	194

Table B.10	Test Parameter Status	195
Table B.11	Test Stack Commands	196
Table B.12	Scan Parameter Status	197
Table B.13	Scan Stack Commands	198
Table B.14	Process Data Channels	199
Table B.15	Communication Channel	200
Table B.16	Token Access	201
Table B.17	Version, System, & RTC Information	202
Table B.18	System Configuration Parameters	203

Appendix C: Timing Diagrams

Appendix D: Signal Diagrams

Chapter 1: Safety and Support



1.1	Safety Requirements and Warnings	2
1.2	General Precautions	4
1.3	Warranty.	6
1.4	How to Contact Branson	7
1.5	Returning Equipment for Repair.	8
1.6	Obtaining Replacement Parts.	11

1.1 Safety Requirements and Warnings

This chapter contains an explanation of the different Safety Notice symbols and icons found both in this manual and on the product itself and provides additional safety information for ultrasonic welding. This chapter also describes how to contact Branson for assistance.

1.1.1 Symbols Found in this Manual

These symbols used throughout this manual warrant special attention:

WARNING	Indicates a possible danger
	If these risks are not avoided, death or severe injury might result.
CAUTION	General Warning
	If these risks are not avoided, slight or minor injury might result.
NOTICE	Indicates a possible damaging situation
	If this situation is not avoided, the system or something in its vicinity might get damaged. Application types and other important or useful information are emphasized.

1.1.2 Symbols Found on the Product

The DCX Power Supply F-DP has several safety-related labels on it to indicate the presence of hazardous voltages inside the unit.

Figure 1.1 Safety-related Labels found on the DCX Power Supply F-DP

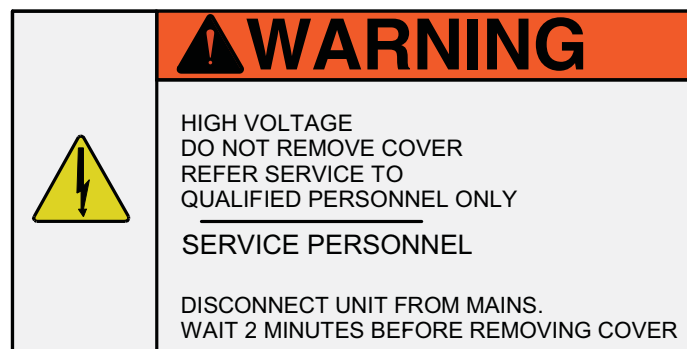

1.2 General Precautions

Take the following precautions before servicing the power supply:

- Be sure the power switch is in the off position before making any electrical connections
- To prevent the possibility of an electrical shock, always plug the power supply into a grounded power source
- To prevent the possibility of an electrical shock, ground the power supply by securing an 8 gauge grounded conductor to the ground screw located next to the air outlet
- Power supplies produce high voltage. Before working on the power supply assembly, do the following:
Turn off the power supply;
Unplug main power; and
Allow at least 2 minutes for capacitors to discharge
- High voltage is present in the power supply. Do not operate with the cover removed
- High line voltages exist in the ultrasonic power supply assembly. Common points are tied to circuit reference, not chassis ground. Therefore, use only non-grounded, battery-powered multimeters when testing the power supply assembly. Using other types of test equipment can present a shock hazard
- Keep hands from under the horn. Down force (pressure) and ultrasonic vibrations can cause injury
- Do not cycle the welding system if either the RF cable or converter is disconnected
- When using larger horns, avoid situations where fingers could be pinched between the horn and the fixture
- Ensure power supply installation is performed by qualified personnel and in accordance with local standards and regulations

CAUTION	Loud Noise Hazard
	<p>Sound level and frequency of the noise emitted during the ultrasonic assembly process may depend upon a. type of application, b. size, shape and composition of the material being assembled, c. shape and material of the holding fixture, d. welder setup parameters and e. tool design.</p> <p>Some parts vibrate at an audible frequency during the process. Some or all of these factors may result in an uncomfortable noise being emitted during the process.</p> <p>In such cases operators may need to be provided with personal protective equipment. See 29 CFR (Code of Federal Regulations) 1910.95 Occupational Noise Exposure.</p>

1.2.1 Intended Use of the System

The DCX Power Supply F-DP and components are designed to be used as part of an ultrasonic welding system. These are designed for a wide variety of welding or processing applications.

If the equipment is used in a manner not specified by Branson, the protection provided by the equipment may be impaired.

Branson Ultrasonics Corporation designs and manufactures machines giving the first priority to safety precautions, to allow customers to use the machines safely and effectively. Only trained operators should run and service the equipment. Untrained

operators can misuse the equipment or ignore safety instructions that can result in personal injury or equipment damage. It is most essential that all operators and service personnel pay attention to safety instructions when operating and servicing the equipment.

1.2.2 Emissions

Because of the various types of toxic or injurious gases that may be liberated during the welding based on the material being processed, sufficient ventilation should be provided to prevent a concentration of these gases in excess of 0.1 ppm. Check with your materials suppliers for recommended protection when processing their materials.

CAUTION	Corrosive Material Hazard
	<p>Processing of many materials, such as PVC, can be hazardous to an operator's health and could cause corrosion/damage to the equipment. Use proper ventilation and take protective measures.</p>

1.2.3 Setting up the Workplace

Measures for setting up a workplace for safe operation of the ultrasonic welder are outlined in [Chapter 5: Installation and Setup](#).

1.2.4 Regulatory Compliance

This product meets electrical safety requirements and EMC (Electromagnetic Compliance) requirements for North America and the European Union.

1.3 Warranty

For warranty information please reference the warranty section of Terms and Conditions found at: www.emerson.com/branson-terms-conditions.

1.4 How to Contact Branson

Branson is here to help you. We appreciate your business and are interested in helping you successfully use our products. To contact Branson for help, use the following telephone numbers, or contact the field office nearest you (business hours from 8 a.m. to 4 p.m. Central and Eastern Time Zones):

- **North American Headquarters (all Departments):** (203) 796-0400
- **Parts Store (direct number):** (877) 330-0406
- **Repair department:** (877)-330-0405
- **For emergency after-hours service (5 p.m. – 8 a.m. EST):** (203) 796-0500 (US phone numbers only)

Tell the operator which product you have and which person or department you need ([Table 1.1 Branson Contacts](#)). If after hours, please leave a voice message with your name and return telephone number.

1.4.1 Before Calling Branson for Assistance

This manual provides information for troubleshooting and resolving problems that could occur with the equipment (see [Chapter 9: Maintenance](#)). If you still require assistance, Branson Product Support is here to help you. To help identify the problem, use the following questionnaire which lists the common questions you will be asked when you contact the Product Support department.

Before calling, determine the following information:

1. Your company name and location.
2. Your return telephone number.
3. Have your manual with you. If troubleshooting a problem, refer to [Chapter 9: Maintenance](#).
4. Know your equipment model and serial numbers (found on a gray data label on the units). Information about the horn (part number, gain, etc.) or other tooling may be etched into the tooling. Software- or firmware-based systems may provide a BOS or software version number, which may be required.
5. What tooling (horn) and booster are being used?
6. What are the setup parameters and mode?
7. Is your equipment in an automated system? If so, what is supplying the “start” signal?
8. Describe the problem; provide as much detail as possible. For example, is the problem intermittent? How often does it occur? How long before it occurs if you are just powering up? If an error is occurring, which error (give error number or name)?
9. List the steps you have already taken.
10. What is your application, including the materials being processed?
11. Have a list of service or spare parts you have on hand (tips, horns, etc.)
12. Notes:

1.5 Returning Equipment for Repair

Before sending equipment for repair, provide as much information with the equipment to help determine the problem with the system. Use the following page to record necessary information.

NOTICE	
	To return equipment to Branson, you must first obtain an RGA number from a Branson representative, or the shipment may be delayed or refused.

If you are returning equipment to Branson for repair, you must first call the Repair department to obtain a **Returned Goods Authorization (RGA)** number. (If you request it, the repair department will fax a Returned Goods Authorization form to fill out and return with your equipment).

Branson Repair Department, C/O Zuniga Logistics, LTD

12013 Sara Road, Killam Industrial Park

Laredo, Texas 78045 U.S.A.

Direct telephone number: (877) 330-0405

Fax number: (877) 330-0404

- Provide as much information as possible that will help identify the need for repair
- Carefully pack the equipment in original packing cartons
- Clearly label all shipping cartons with the RGA number on the outside of cartons as well as on your packing slip, along with the reason for return
- Return general repairs by any convenient method. Send priority repairs by air freight
- You must prepay the transportation charges FOB Laredo, Texas, U.S.A.

1.5.1 Get an RGA Number

RGA#

If you are returning equipment to Branson, please call the Repair Department to obtain a Returned Goods Authorization (RGA) number. (At your request, the Repair Department will fax an RGA form to fill out and return with the equipment.)

1.5.2 Record Information About the Problem

Before sending equipment for repair, record the following information and send a copy of it with the equipment. This will greatly increase Branson's ability to address the problem.

1. Describe the problem; provide as much detail as possible. For example, is the problem intermittent? How often does it occur? How long before it occurs after powering up?

2. Is your equipment in an automated system?

3. If the problem is with an external signal, which signal?

4. If known, include plug/pin # (e.g., P29, pin #3) for that signal:

5. What are the Weld Parameters?

What is your application? (Type of weld, plastic material, etc.):

Name and phone number of the person most familiar with the problem:

Contact the Branson office prior to shipping the equipment.

For equipment not covered by warranty, to avoid delay, include a Purchase Order.

Send a copy of this page with the equipment being returned for repair.

1.5.3 Departments to Contact

Call your local Branson Representative, or contact Branson by calling and asking for the appropriate department, as indicated in [Table 1.1 Branson Contacts](#) below.

Table 1.1 Branson Contacts

What you need help with or information about	Whom to Call	At this Phone Number...
Information about new welding systems or components	Your local Branson Rep or Branson Customer Service	203-796-0400 Ext 384
Application and setup questions on the welding system	Welding Applications Lab	203-796-0400 Ext 368
Application assistance on the horns and tooling	ATG Lab	203-796-0400 Ext 495
Technical questions about the welding system	Welding Product Support	203-796-0400 Ext 355, 551
Technical questions about horns and tooling	ATG Lab	203-796-0400 Ext 495
Ordering new parts	Parts Store	877-330-0406
RGA's, request for repair, status of a repair	Welding Repair Department	877-330-0405
System automation/hookup information	Product Support	203-796-0400 Ext 355, 551

My Local Branson Representative's name is:

I can reach this representative at:

1.5.4 Pack and Ship the Equipment

1. Carefully pack the system in original packing material to avoid shipping damage. Plainly show the RGA number on the outside of cartons as well as inside the carton along with the reason for return. Make a list of all components packed in the box. KEEP YOUR MANUAL.
2. Return general repairs by any convenient method. Send priority repairs by air freight. Prepay the transportation charges FOB the repair site.

NOTICE	
	Items that are sent Freight Collect will be refused.

1.6 Obtaining Replacement Parts

You can reach Branson Parts Store at the following telephone numbers:

Branson Part Store

Direct telephone number: 877-330-0406

Fax number: 877-330-0404

Many parts can be shipped the same day if ordered before 2:30 p.m., Eastern time.

A parts list is found in [Chapter 9: Maintenance](#) of this manual, listing descriptions and EDP part numbers. If you need replacement parts, coordinate the following with your purchasing agent:

- Purchase order number
- Ship to information
- Bill to information
- Shipping instructions (air freight, truck, etc.)
- Any special instructions (for example, "Hold at the airport and call"). Be sure to give a name and phone number
- Contact name information



Chapter 2: Introduction

2.1	Models Covered	14
2.2	Compatibility with other Branson Products	16
2.3	Features	17
2.4	Controls and Indicators	19
2.5	Welding Systems	25
2.6	Glossary	26

2.1 Models Covered

This manual covers all models of the DCX Power Supply F-DP.

Table 2.1 Models Covered in this Manual

Frequency	Power	Model	EDP
20 kHz	1250 W	Horizontal	101-132-1850
		Vertical	101-132-1857
	2500 W	Horizontal	101-132-1851
		Vertical	101-132-1858
	4000 W	Horizontal	101-132-1852
		Vertical	101-132-1859
30 kHz	750 W	Horizontal	101-132-1853
		Vertical	101-132-1860
	1500 W	Horizontal	101-132-1854
		Vertical	101-132-1861
40 kHz	400 W	Horizontal	101-132-1849
		Vertical	101-132-1856
	800 W	Horizontal	101-132-1855
		Vertical	101-132-1862

2.1.1 Overview of these Models

Figure 2.1 The DCX Power Supply F-DP (Horizontal)



Figure 2.2 The DCX Power Supply F-DP (Vertical)



2.2 Compatibility with other Branson Products

Table 2.2 Power Supply Compatibility with Branson Converters

DCX F-DP Model	Converter
20 kHz / 1250 W 20 kHz / 2500 W 20 kHz / 4000 W	CR-20
	CR-20S
	CR-20C
	CH-20S (932 AH SPL)
	CH-20C
	CS-20S
	CS-20C
30 kHz / 750 W 30 kHz / 1500 W	CR-30S
	CR-30C
	CH-30S
	CH-30C
	CS-30S
	CS-30C
40 kHz / 400 W 40 kHz / 800 W	CR-40S (4TH)
	CR-40C
	4TP
	4TR

NOTICE	
	<p>Special adaptor cables are available to connect to MS-style converters (CR20 and 4TR). See Table 9.8 DCX Power Supply F-DP System Cables.</p>

2.3 Features

2.3.1 The Welding System

The DCX Power Supply F-DP generates ultrasonic energy through an ultrasonic converter for welding plastics. Several models are available, depending on the desired frequency (for example, 20 kHz), the desired power range (for example, 2.5 kW), and the intended mounting arrangement (horizontal or vertical). The power supply also contains a microprocessor-based controller module that provides for control and monitoring of welding operations.

The welding system consists of a DCX Power Supply F-DP and a converter-booster-horn stack. The system can perform ultrasonic welding, inserting, staking, spot welding, swaging, degating, and continuous ultrasonic operations. It is designed for automated, semi-automated and/or manual production operations.

2.3.2 The Power Supply

The DCX Power Supply F-DP consists of an ultrasonic power supply assembly with a system controller and user interfaces. The ultrasonic power supply assembly converts conventional 50/60 Hz line current to 20 kHz, 30 kHz or 40 kHz electrical energy. The system controller controls the welding system.

Listed below are the control features of the Branson DCX Power Supply F-DP ultrasonic welding system

- **Autotuning:** Branson power supply tuning ensures that the system is running at peak efficiency
- **Digital Amplitude Setting:** This feature allows you to set the exact amplitude necessary for your application, allowing increased range and setting repeatability over analog systems
- **Frequency Offset:** This process feature allows a user to set an offset relative to the starting frequency, for certain specific applications, where the force imparted on the fixture or anvil causes a frequency shift in the stack's operation. You should only use this feature when advised to do so by Branson
- **Horn Signature:** Using the DCX Web Page Interface, you may scan your ultrasonic stack to view its operating frequency on your computer, using digital readouts to give you the best picture of the stack's operation
- **LCD (Liquid Crystal Display):** Provides a clear visual interface to monitor and configure the system
- **Line Regulation:** Maintains converter amplitude by regulating for variances in the line voltages
- **Load Regulation:** Maintains converter amplitude over the full range of rated power
- **Membrane Keys:** Front panel controls are designed for high reliability and immunity from factory dust and oils
- **User ID and Passcodes:** Allows for keeping track of user access to the DCX Power Supply F-DP Web Page Interface
- **PROFIBUS DP:** Via a single bus cable, PROFIBUS links controller or control systems with decentralized field devices (sensors and actuators) on the field level and also enables consistent data exchange with higher ranking communication systems
- **Ramp Starting:** The starting of the DCX Power Supply F-DP and horn is done at a rate that helps reduce electrical and mechanical stress on the system. The horn start rate may be adjusted for some tough-to-start applications
- **Seek:** Ensures operation at resonance; minimizes tuning errors; and operates the stack at low amplitude (10%), then provides a means of sensing and storing the resonant operating frequency value
- **Start-up Diagnostics:** At start-up, the controls test the major internal components
- **System Protection:** Protects the power supply by providing six levels of protection: Voltage, Current, Phase, Temperature, Power and Frequency

- **Timed Seek:** When enabled, will do a Seek once every minute to update horn resonant frequency to memory. This is especially useful when the welding process affects the actual temperature of the horn, causing a resonant frequency shift
- **True Wattmeter:** The controls on the power supply include a true wattmeter for accurate measurement of power and energy
- **Web Page Interface:** Provides access, via Ethernet connection, to power supply information, diagnostics, and configuration web pages

2.3.3 The Actuator

The DCX Power Supply F-DP can interface with actuator signals, only when operating in manual mode.

2.3.4 Converter/Booster/Horn Assembly

The Converter

The ultrasonic electrical energy from the power supply is applied to the converter (sometimes called the transducer). This transforms the high frequency electrical oscillations into mechanical vibrations at the same frequency as the electrical oscillations. The heart of the converter is piezoelectric ceramic elements. When subjected to an alternating voltage, these elements alternately expand and contract, resulting in better than 90% conversion of electrical to mechanical energy.

The Booster

Success in ultrasonic assembly depends on the right amplitude of movement at the horn face. Amplitude is a function of horn shape, which is largely determined by the size and form of the parts to be assembled. The booster can be used as a mechanical transformer to increase or decrease the amplitude of vibrations applied to the parts through the horn.

The booster is a resonant half-wave section of aluminum or titanium. It is mounted between the converter and the horn, as part of the ultrasonic stack. It also provides a clamping point for rigid stack mounting.

Boosters are designed to resonate at the same frequency as the converter with which they are used. Boosters are usually mounted at a nodal (minimum vibration) point of axial motion. This minimizes the loss of energy and prevents vibration from being transmitted to the stack supporting structure.

The Horn

The horn is selected or designed for a specific application. Each horn is tuned typically as a half-wave section that applies the necessary force and vibration uniformly to the parts to be assembled. It transfers ultrasonic vibrations from the converter to the workpiece. The horn is mounted to the booster as part of the ultrasonic stack.

Depending on their profile, horns are referred to as stepped, conical, exponential, bar, or catenoidal. The shape of the horn determines the amplitude at the face of the horn. Depending on the application, horns can be made from titanium alloys, aluminum, or steel. Titanium alloys are the best materials for horn fabrication due to their high level of strength and low loss. Aluminum horns are usually chrome- or nickel-plated or hard-coated to reduce wear. Steel horns are for low amplitude requiring hardness, such as ultrasonic insertion applications.

2.4 Controls and Indicators

2.4.1 DCX Power Supply F-DP Front Panel

Figure 2.3 DCX Power Supply F-DP Front Panel Controls and Indicators



Table 2.3 DCX Power Supply F-DP Front Panel Controls and Indicators



Reference	Description
	<p>LCD</p> <p>For detailed information refer to Figure 2.4 LCD Description and Table 2.4 LCD Description.</p>
	<p>Up/Down Keys</p> <p>Use to adjust the amplitude of ultrasonic vibrations (10% to 100%). Also used to adjust weld mode parameters, select registers and edit register values.</p>
	<p>Alarm Reset Key</p> <p>Use the Reset key to reset alarms.</p> <p>When changing system registers, use the Reset key to set a register back to its default value after entering the register and before editing the value.</p>
	<p>Configuration Key</p> <p>Use the Configuration key to change system registers. For information on using the Configuration key to set system registers see 7.4 Configuring the Power Supply Registers.</p>

Table 2.3 DCX Power Supply F-DP Front Panel Controls and Indicators





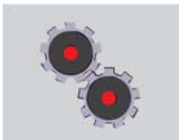

Reference	Description
	<p>Ultrasonics Test Key</p> <p>Use the Test key to perform an ultrasonic test. Test performs a seek and then ramps the amplitude to the current setting.</p>
	<p>PROFIBUS DP Connector</p> <p>Use the PROFIBUS DP Connector to connect the DCX Power Supply F-DP to a master/slave PROFIBUS DP network. For more information, refer to Chapter 5: Installation and Setup and Chapter 7: Operation.</p>
	<p>Ethernet Port</p> <p>Use the Ethernet Port to connect to the DCX Power Supply F-DP Web Page Interface.</p>
	<p>Power-On Indicator</p> <p>Lights when the power supply is connected to main power and the power switch is on.</p>
	<p>24 V Indicator</p> <p>Lights when 24 V DC are supplied to the DCX Power Supply F-DP.</p>
	<p>PROFIBUS DP Status Indicator</p> <p>Indicate the status of the PROFIBUS DP module. For more information see Chapter 7: Operation.</p>

Figure 2.4 LCD Description

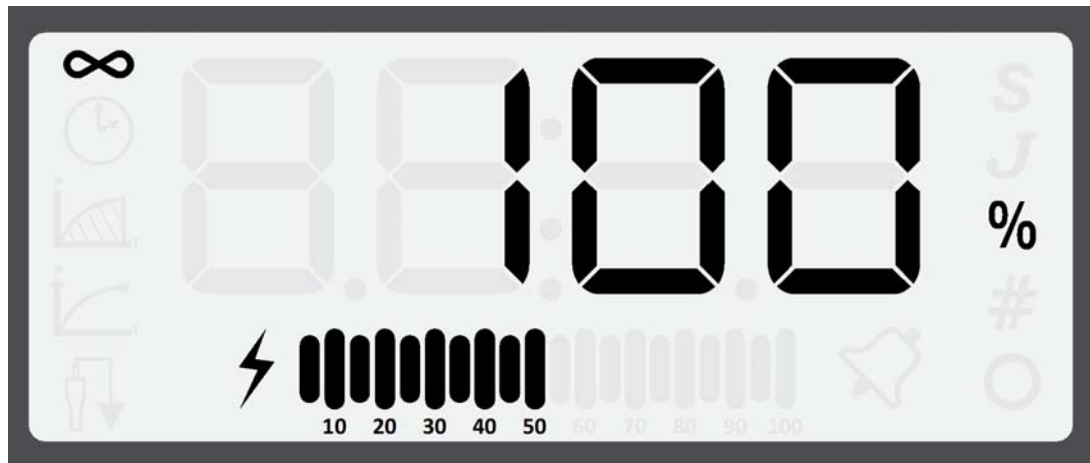

Table 2.4 LCD Description





Reference	Description
	<p>Numeric Display</p> <p>Displays the Power Supply amplitude settings, weld time settings, weld energy settings, peak power settings, scrub time settings, register numbers, register values or alarm numbers.</p>
	<p>Continuous Mode Icon</p> <p>Indicates the power supply is running in Continuous mode. When in Continuous mode, the amplitude setting is shown on the numeric display in conjunction with the % icon. The amplitude setting may range from 10% to 100%. For more information see Chapter 7: Operation.</p>
	<p>Time Mode Icon</p> <p>Indicates the power supply is running in Time mode. When in Time mode, the weld time setting is shown on the numeric display in conjunction with the S icon. The weld time setting can range from 10 ms to 30 seconds. For more information see Chapter 7: Operation.</p>
	<p>Energy Mode Icon</p> <p>Indicates the power supply is running in Energy mode. When in Energy mode, the weld energy setting is shown on the numeric display in conjunction with the J icon. The energy setting may range from 1 Joule to 9999 Joules. For more information see Chapter 7: Operation.</p>

Table 2.4 LCD Description







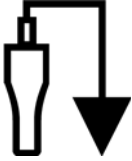

Reference	Description
	<p>Peak Power Icon</p> <p>Indicates the power supply is running in Peak Power mode. When in Peak Power mode, the peak power percentage is shown on the numeric display in conjunction with the % icon. The peak power setting may range from 1% to 100% of the maximum power supply output power. For more information see Chapter 7: Operation.</p>
	<p>Ground Detect Icon</p> <p>Indicates the power supply is running in Ground Detect mode. When in Ground Detect mode, the scrub time setting will be shown on the numeric display in conjunction with the S icon. Scrub time setting may range from 1 millisecond to 500 milliseconds. For more information see Chapter 7: Operation.</p>
	<p>Sonics Active Indicator</p> <p>Indicates ultrasonics is running.</p>
	<p>Time Icon</p> <p>Indicates that the value shown on the numeric display represents time in seconds.</p>
	<p>Joule Icon</p> <p>Indicates that the value shown on the numeric display represents energy.</p>
	<p>Percentage Icon</p> <p>Indicates that the value shown on the numeric display represents a percentage. When in Peak Power mode, the value shown on the numeric display represents a percentage of the power supply rated power. If not in Peak Power mode, the value shown on the numeric represents the amplitude setting.</p>
	<p>Number Sign Icon</p> <p>Indicates that the value shown on the numeric display is a register number. Use up and down keys to select a register. For more information see 7.4 Configuring the Power Supply Registers.</p>

Table 2.4 LCD Description

Reference	Description
	<p>Circle Icon</p> <p>Indicates that the value shown on the numeric display is a register value. Use up and down keys to modify the register value. For more information see 7.4 Configuring the Power Supply Registers.</p>
	<p>Alarm Icon</p> <p>A flashing icon which indicates an alarm condition.</p>
	<p>Power/Frequency Bar-Graph</p> <p>Shows the true percentage of ultrasonic power during a weld cycle. The bar-graph can be configured to show the peak power or the memory frequency at the end of each weld or test cycle. For instructions on how to modify this setting see 7.4 Configuring the Power Supply Registers.</p> <p>For detailed bar-graph description and bar-graph reading examples, see 7.5.2 Frequency Bar-Graph Interpretation.</p>

2.4.2 DCX Power Supply F-DP Connections

Figure 2.5 DCX Power Supply F-DP Back Panel (Horizontal)

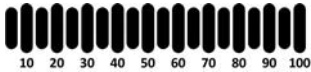

Figure 2.6 DCX Power Supply F-DP Bottom Panel (Vertical)

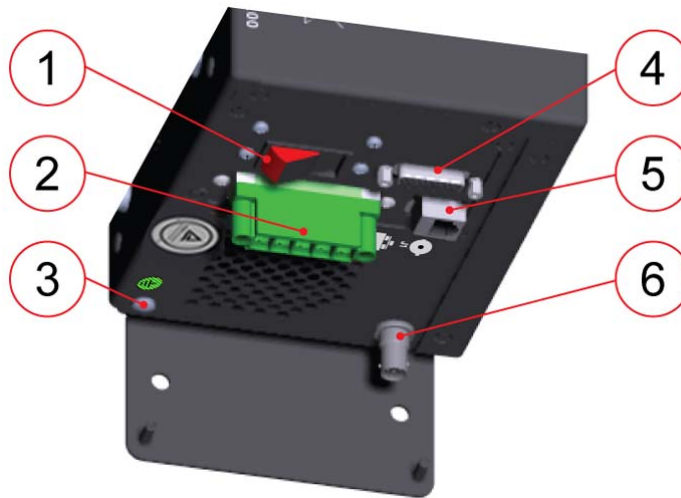

Table 2.5 Connections to the DCX Power Supply F-DP

Item	Name	Function
1	Circuit Breaker / Power Switch	Turns the AC main power on or off.
2	Line Input Connector	Detachable connector block for connecting the input power. For wiring details refer to Chapter 5: Installation and Setup .
3	Ground Screw	Ground screw to serve as a redundant safety measure.
4	User I/O Connector	Provides the necessary input/output signals to interface with actuators, user automation or control interfaces. For detailed information on interfacing with the DCX Power Supply F-DP refer to Chapter 5: Installation and Setup .
5	Ethernet Port	Use the Ethernet Port to connect to the DCX Power Supply F-DP Web Page Interface.
6	RF Connector	SHV connector for RF cable, which provides ultrasonic energy to the converter.

2.5 Welding Systems

2.5.1 Principle of Operation

Thermoplastic parts are welded ultrasonically by applying high frequency vibrations to the parts being assembled. The vibrations, through surface and intermolecular friction, produce a sharp rise in temperature at the welding interface.

When the temperature is high enough to melt the plastic, there is a flow of material between the parts. When the vibrations stop, the material solidifies under pressure and a weld results.

2.5.2 Weld System Applications

DCX Power Supply F-DP weld systems can be used for the following applications:

- Ultrasonic welding
- Cutting and sealing thermoplastic fabric and film
- Staking, spot welding, swaging, and degating thermoplastic parts
- Other ultrasonic processing applications

2.6 Glossary

The following terminology may be encountered when using or operating a DCX Power Supply F-DP ultrasonic welding system:

- **Actuator:** The unit which houses the converter/booster/horn stack assembly in a rigid mounting, allowing the stack to move up and down, either mechanically or pneumatically, applying force to the part at a user-adjustable force and velocity
- **Alarm:** Visual indication of error
- **Amplitude Control:** The ability to set amplitude digitally or by an external control
- **Amplitude:** The peak-to-peak movement at the horn face. Always expressed as a percentage of the maximum
- **Booster:** A one-half-wavelength-long resonant metal section mounted between the converter and horn, sometimes having a change in cross-sectional area between the input and output surfaces. The booster mechanically alters the amplitude of vibrations received from the converter, and imparts the new amplitude to the horn
- **Clamping Force:** The pounds or kilograms exerted by the horn onto the workpiece
- **Cold Start:** Restores the settings of the power supply back to its original condition
- **Converter:** The device that converts electrical energy into mechanical vibrations at a high frequency (an ultrasonic rate)
- **Counters:** A record of the number of preset cycles recorded in the power supply
- **Degating:** Removing a molded part from its runner system
- **Energy Director:** A triangular-shaped projection of plastic material which concentrates the ultrasonic energy at the joint interface of a plastic part
- **External Amplitude Control:** Enables you to access real-time amplitude control directly via the user I/O connector
- **External Frequency Control:** Enables you to access real-time frequency offset control directly via the user I/O connector
- **Fieldbus:** Computer network protocols for industrial two way communications used for real-time distributed control
- **Fixture:** A device for holding a part in position for assembly
- **Flash:** Material displaced from the joint area
- **Forming:** Reshaping a section of thermoplastic
- **Fretting Corrosion:** A black surface condition, that results from friction between metal parts, that appears on the converter-booster-horn stack mating surfaces
- **Frequency:** The operating frequency of the ultrasonic stack. The frequency stored is measured at the end of the ultrasonic portion of the cycle (when ultrasonics are terminated)
- **Frequency Offset:** An offset factor applied to the ultrasonic frequency stored in the power supply
- **Gain:** The ratio of output to input amplitude of a horn or booster
- **Horn:** A bar or metal section, usually one half-wavelength-long which transfers vibratory energy to the workpiece
- **Horn Amplitude:** The peak-to-peak displacement of a horn at its work face
- **Horn Signature:** A scan to enhance selection of operating frequency and control parameters
- **Insertion:** The process of embedding a metal component in plastic
- **Interface:** 1. The contact surface of two mating parts. 2. The connection between two pieces of equipment
- **Joint:** The weld surfaces
- **Parameter:** A unique factor or element which affects the welding operation in a particular mode
- **Parameter Range:** Valid range of parameters accepted for a particular setup

- **Power Supply:** The electronic instrument in an ultrasonic assembly system which changes conventional 50/60 Hz electrical power into high frequency electrical power at 20 kHz, 30 kHz or 40 kHz
- **PROFIBUS DP (Decentralized Peripherals):** Used to operate sensors and actuators via a centralized controller in production automation applications
- **Seek:** The activation of ultrasonics at a low-level (10%) amplitude, for the purpose of finding the resonant frequency of the stack
- **Staking:** The process of melting and reforming a plastic stud to mechanically lock a dissimilar material in place
- **Swaging:** The process of capturing another component of an assembly by melting and reforming a ridge of plastic
- **Thermoplastic:** A polymer which undergoes a reversible change of state when subjected to heat
- **Thermoset:** A polymer which undergoes an irreversible change when subjected to heat
- **Token:** Token is a concept that applies to who can make a change to the preset. If the fieldbus has gotten the token, then only the fieldbus can perform a change. However, if fieldbus has not gotten the token (or has released the token), then the preset can be changed by any other means, for example, via Web Page or front panel controls
- **Ultrasonic Power:** Presence of ultrasonic power at the horn face
- **Ultrasonic Welding:** The use of ultrasonic vibrations to generate heat and subsequently melt the mating surfaces of two thermoplastic parts. When ultrasonic vibrations stop, the molten material resolidifies, and a weld occurs
- **User ID:** A unique 12 character long alphanumeric ID used to keep track of user access to the web page interface
- **Weld System:** A combination of components required to perform an ultrasonic operation. Usually consists of a power supply, converter, booster, and horn, with either an actuator or a handheld device, or in a fixed, mounted location

Chapter 3: Delivery and Handling

3.1	Shipping and Handling	30
3.2	Receiving	31
3.3	Unpacking the Power Supply	32
3.4	Take Inventory of Small Parts	33
3.5	Returning Equipment	34

3.1 Shipping and Handling

CAUTION	Heavy Object
	<p>The power supply may be heavy. Handling, unpacking, and installation may require the assistance of a colleague or the use of lifting platforms or hoists.</p>

3.1.1 Environmental Specifications

The DCX Power Supply F-DP is an electronic unit that converts line voltage to ultrasonic energy and responds to user input for regulating the weld process. Its internal components are sensitive to static discharge, and many of its components can be harmed if the unit is dropped, shipped under improper conditions, or otherwise mishandled.

The following environmental guidelines should be respected in the shipping of the power supply.

Table 3.1 Shipping Specifications

Environmental Condition	Acceptable Range
Storage / Shipping Temperature	-25° C / -13° F to +55° C / +131° F (+70° C / +158° F for 24 hours)
Shock / Vibration (transit)	45 g shock / 0.5 g and (3 to 100 Hz) vibration per ASTM 3332-88 and 3580-90
Drop Test	ISTA Procedure 1 & 2A (while packaged)
Humidity	Maximum 95%, non-condensing

3.2 Receiving

The DCX Power Supply F-DP is a sensitive electronic device. Many of its components can be harmed if the unit is dropped or otherwise mishandled.

Scope of Delivery

Branson equipment is carefully checked and packed before dispatch. It is recommended, however, that you follow the procedure below upon receiving your DCX Power Supply F-DP.

Inspect the Power Supply when it is delivered, take the following steps.

Table 3.2 Inspect the Power Supply

Step	Action
1	Verify that all parts are complete according to the packing slip.
2	Check the packing and the unit for damage (visual inspection).
3	Report any damage claims to your carrier immediately.
4	Determine if any component has become loose during shipping and, if necessary, tighten screws.

NOTICE	
	<p>If the goods delivered have been damaged during shipping, please contact the forwarding agent immediately. Retain packing material (for possible inspection or for sending back the unit).</p>

3.3 Unpacking the Power Supply

NOTICE	
	<p>If there are any visible signs of damage to the shipping containers or the product, or you later discover hidden damage, NOTIFY YOUR CARRIER IMMEDIATELY. Save the packing material.</p>

The power supply is fully assembled. It is shipped in a sturdy cardboard box. Some additional items are shipped in the box with the power supply. Note orientation of packaging material in case return/repack is necessary. When unpacking the power supply, take the following steps:

Table 3.3 Unpacking the Power Supply

Step	Action
1	Unpack the power supply as soon as it arrives. Save the packing material
2	Verify you have all of the equipment ordered. Some components are packed inside other boxes.
3	Inspect the controls, indicators, and surface for signs of damage.
4	Remove the cover of the power supply to check if any components became loose during shipping.

3.4 Take Inventory of Small Parts

Table 3.4 Small Parts included: Power Supply Assemblies

Part or Kit	20 kHz	30 kHz	40 kHz
Mylar® * plastic film Washer Kit	X	X	
Silicone Grease			X
Spanners (2)	X	X	X

* Mylar is a registered trademark of DuPont Teijin Films.

3.4.1 Cables

The RF cable connects the power supply to the converter. For automated systems you will also need a user I/O cable to monitor and control the power supply. Check your invoice for cable types and cable lengths.

Table 3.5 DCX Power Supply F-DP System Cables

P/N	Description
100-240-383	Cable, RF 8 ft (2.5 m)
100-240-384	Cable, RF 15 ft (4.5 m)
100-240-385	Cable, RF 25 ft (7.5 m)
100-240-387	Cable, RF right angle 8 ft (2.5 m)
100-240-388	Cable, RF right angle 15 ft (4.5 m)
100-240-389	Cable, RF right angle 25 ft (7.5 m)
100-240-391	Cable, RF adaptor for CR20 converter 3 ft (0.9 m)
100-240-392	Cable, User I/O 25 ft (7.5 m)
100-240-393	Cable, User I/O 50 ft (15 m)
200-240-396	Cable Ethernet Cat 5e 7 ft (2.1 m)
100-240-397	Cable, RF adaptor for 4TR converter 3 ft (0.9 m)

3.5 Returning Equipment

If you are returning equipment to Branson Ultrasonic Corporation, please call your Customer Service Representative to receive approval to return the goods. Refer to [1.4 How to Contact Branson](#).

Chapter 4: Technical Specifications

4.1	Technical Specifications	36
4.2	Physical Description	38
4.3	Declaration of Conformity	39
4.4	PROFIBUS Certificate	41

4.1 Technical Specifications

NOTICE	
	All specifications are subject to change without notice.

4.1.1 Environmental Specifications

The DCX Power Supply F-DP has the following environmental specifications:

Table 4.1 Environmental Specifications

Environmental Condition	Acceptable Range
Ambient Operating Temperature	+41° F to +104° F (+5° C to +40° C)
Storage / Shipping Temperature	-13° F to +131° F (-25° C to +55° C)
Humidity	Maximum 95%, non-condensing
IP Rating	2X

NOTICE	
	Cooling fan is the thermostat controller.

4.1.2 Electrical Specifications

The following tables list input voltage and current requirements for the DCX Power Supply F-DP.

Electrical Input Operating Voltages

Table 4.2 Electrical Input Operating Voltages

Power Supply Rating	Input Operating Voltage
All Models	200 V to 240 V Nominal (180 V Min.* to 253 V Max.), 50 Hz or 60 Hz, Single Phase
	24 VDC, 2.5 A

* 200 V Min. for 4 kW units.

Input Current and Circuit Breaker Specifications

Table 4.3 Input Current and Circuit Breaker Specifications

Model	Power	Current Rating
20 kHz	1250 W	7 A Max. @ 200 - 240 V / 15 A Breaker
	2500 W	14 A Max. @ 200 - 240 V / 25 A Breaker
	4000 W	25 A Max. @ 200 - 240 V / 25 A Breaker
30 kHz	750 W	5 A Max. @ 200 - 240 V / 10 A Breaker
	1500 W	10 A Max. @ 200 - 240 V / 15 A Breaker
40 kHz	400 W	3 A Max. @ 200 - 240 V / 10 A Breaker
	800 W	5 A Max. @ 200 - 240 V / 10 A Breaker

Continuous Duty Maximum Power

Table 4.4 Continuous Duty Maximum Power

Model	Power	Continuous Duty Max. Power
20 kHz	1250 W	800 W
	2500 W	1600 W
	4000 W	2000 W
30 kHz	750 W	300 W
	1500 W	800 W
40 kHz	400 W	300 W
	800 W	400 W

NOTICE



High duty cycles require additional cooling for the converter. For information on converter cooling refer to [5.7 Converter Cooling](#) in [Chapter 5: Installation and Setup](#).

NOTICE



System average power must be limited to the specified continuous maximum. Higher peak power, up to the maximum acceptable power limit, with an on time of up to 10 seconds may be obtained if appropriate off time ensures that, on average, the Continuous Duty Maximum Power is not exceeded.

Cycle Rate – up to 200 cpm. Cycle rate including off time is application and stack dependent.

4.2 Physical Description

This section describes the physical dimensions of the DCX Power Supply F-DP.

NOTICE	
	Dimensions are nominal.

Table 4.5 Dimension and Weight of DCX Power Supply F-DP

Size	Width	Height	Depth	Weight
Small (Benchtop)	14" 356 mm	5.5" 132 mm	7.4" 187 mm	16 lb 7.2 kg
Small (Vertical)	5.2" 132 mm	14" 356 mm		
Medium (Benchtop)	14" 356 mm	5.5" 132 mm	8.6" 219 mm	18 lb 8.2 kg
Medium (Vertical)	5.2" 132 mm	14" 356 mm		
Large (Benchtop)	14" 356 mm	5.5" 132 mm	10.6" 270 mm	22 lb 10 kg
Large (Vertical)	5.2" 132 mm	14" 356 mm		

For detailed dimensional information refer to [Chapter 5: Installation and Setup](#).

4.3 Declaration of Conformity

Figure 4.1 EU Declaration of Conformity

DocuSign Envelope ID: B0909E8A-D9E3-4295-81B6-06331CD21321

EU DECLARATION OF CONFORMITY
According to Low Voltage Directive 2014/35/EU,
EMC Directive 2014/30/EU,
and RoHS Directive 2011/65/EU.



We, the manufacturer

BRANSON ULTRASONICS CORPORATION
120 Park Ridge Rd
Brookfield, CT 06804
USA

represented in the community by

BRANSON ULTRASONICS, a.s.
Piestanska 1202
91501 Nove Mesto nad Vahom
Slovak Republic

expressly declare under our sole responsibility that the following electrical equipment product:

Ultrasonic Assembly System consisting of an Ultrasonic Power Supply, model:

0.40DCX(s, v, a, f-dp or f-eip)40(VRT, V, H or HOR)
0.80DCX(s, v, a, f-dp or f-eip)40(VRT, V, H or HOR)
0.75DCX(s, v, a, f-dp or f-eip)30(VRT, V, H or HOR)
1.50DCX(s, v, a, f-dp or f-eip)30(VRT, V, H or HOR)
1.25DCX(s, v, a, f-dp or f-eip)20(VRT, V, H or HOR)
2.50DCX(S+, s, v, a, f-dp or f-eip)20(VRT, V, H or HOR)
4.00DCX(S+, s, v, a, f-dp or f-eip)20(VRT, V, H or HOR)
4.00DCXs20HD -V
P/S 0.8 DCX S HD 40 VRT
1.50 DCX-S HD 30 HOR
1.50 DCX-S HD 30 VRT
4.00DCXs20HD -H
P/S 0.8 DCX S HD 40 HOR
P/S 4.0KW 20KHZ DCX S LIM RES

used with converter model: CR-20, CR-20S, CR-20C, CH-20C, CS-20S, CS-20C, CR-30, CR-30C, CH-30, CH-30C, CS-30S, CS-30C, CR-40C, 4TR, 4TH, 4TP or 932, and associated cables.

in the state in which it was placed on the market, fulfills all the relevant provisions of:

Low Voltage Directive **2014/35/EU**
EMC Directive **2014/30/EU**
RoHS Directive **2011/65/EU**

The object of this declaration is in conformity with relevant Union harmonization legislation. The electrical equipment product, to which this declaration relates, is in conformity with the following standards:

EN 61010-1:2010+A1:2019
EN 55011:2016/A11:2020
EN 61000-6-2:2005/AC:2005

Brookfield, CT, USA
March 29, 2022

DocuSigned by:
Luis Benavides
018235BFCDE147C
Luis Benavides
Product safety Officer

Figure 4.2 UK Declaration of Conformity

DocuSign Envelope ID: CBF9A5E3-CFF5-43C8-B1AA-6F0C89C3A63B



UK DECLARATION OF CONFORMITY

We, the manufacturer

BRANSON ULTRASONICS CORPORATION

120 Park Ridge Rd.
Brookfield, CT 06804
USA

expressly declare under our sole responsibility that the following electrical equipment product:

Ultrasonic Assembly System consisting of an Ultrasonic Power Supply, model:

0.40DCX(s, v, a, f-dp or f-eip)40(VRT, V, H or HOR)
0.80DCX(s, v, a, f-dp or f-eip)40(VRT, V, H or HOR)
0.75DCX(s, v, a, f-dp or f-eip)30(VRT, V, H or HOR)
1.50DCX(s, v, a, f-dp or f-eip)30(VRT, V, H or HOR)
1.25DCX(s, v, a, f-dp or f-eip)20(VRT, V, H or HOR)
2.50DCX(S+, s, v, a, f-dp or f-eip)20(VRT, V, H or HOR)
4.00DCX(S+, s, v, a, f-dp or f-eip)20(VRT, V, H or HOR)
4.00DCXs20HD -V
P/S 0.8 DCX S HD 40 VRT
1.50 DCX-S HD 30 HOR
1.50 DCX-S HD 30 VRT
4.00DCXs20HD -H
P/S 0.8 DCX S HD 40 HOR
P/S 4.0KW 20KHZ DCX S LIM RES

used with converter model: CR-20, CR-20S, CR-20C, CH-20C, CS-20S, CS-20C, CR-30, CR-30C, CH-30, CH-30C, CS-30S, CS-30C, CR-40C, 4TR, 4TH, 4TP or 932, and associated cables.

in the state in which it was placed on the market, fulfills all the relevant provisions of:

Electrical Equipment (Safety) Regulations **2016**
Electromagnetic Compatibility Regulations **2016**
Restriction of the Use of Certain Hazardous Substances in Electrical and Electronic Equipment Regulations **2012**.

The electrical equipment product, to which this declaration relates, is in conformity with the following designated standards:

BS EN 61010-1:2010+A1:2019
BS EN 55011:2016/A11:2020
BS EN 61000-6-2:2005/AC:2005

Brookfield, CT, USA
March 22, 2022

DocuSigned by:
Luis Benavides
0182350F CDE 147C
Luis Benavides
Product safety Officer

4.4 PROFIBUS Certificate

Figure 4.3 PROFIBUS Certificate



Certificate

PROFIBUS Nutzerorganisation e.V. grants to

Branson Ultrasonics Corporation
41 Eagle Road, 06810 Danbury, Connecticut, USA

the Certificate No: **Z01818** for the PROFIBUS Device:

Model Name: DCX AF Power Supply
Revision: 1.0; SW/FW: 6.0; HW: 102-242-991R, REV3
GSD: BRAN0E05.GSD, File Version: 1.1

This certificate confirms that the product has successfully passed the certification tests with the following scope:

<input checked="" type="checkbox"/>	DP-V0	MS0
<input checked="" type="checkbox"/>	Physical Layer	RS485

Test Report Number: **PB 171-1**
 Authorized Test Laboratory: **PROFI Interface Center, Johnson City, USA**

The tests were executed in accordance with the following documents:
 "Test Specifications for PROFIBUS DP Slaves, Version 3.0, November 2005".
 This certificate is granted according to the document:
 "Framework for testing and certification of PROFIBUS and PROFINET products".
 For all products that are placed in circulation by February 12, 2016 the certificate is valid for life.

 (Official in Charge)

Board of PROFIBUS Nutzerorganisation e. V.

 (Karsten Schneider)



 (K.-P. Lindner)

4.4.1 Terms of use for Trademarks of PROFIBUS & PROFINET International PI

Figure 4.4 Association Trademark



Figure 4.5 Technology Trademarks



Figure 4.6 Certification Trademark



Figure 4.7 Certified by PI Trademark



The Association Trademark, the Technology Trademarks, the Certification Trademark and the Certified by PI Trademark are protected trademarks.

General Terms

The Association Trademark, the Technology Trademarks, the Certification Trademark and the Certified by PI Trademark may only be used in the registered form in the course of business by holders of the right of use.

The Association Trademark, Technology Trademarks, Certification Trademark or the Certified by PI Trademark may not be modified with respect to the registered form or combined with other characteristics than the additions approved by PI.

The granted rights to the Association Trademark, the Technology Trademarks, the Certification Trademark and the Certified by PI Trademark terminate as soon as the necessary conditions for the grant of the rights are no longer satisfied.

Terms of use for Association Trademark (PI Logo)

The right to use the Association Trademark is acquired through membership in one of the Regional PI Associations. Non-members are not granted any rights to use the Association Trademark.

Terms of use for Technology Trademarks (PROFIBUS, PROFINET, PROFI safe, and PROFI energy Logo)

The right to use the Technology Trademarks is acquired through membership in one of the Regional PI Associations. Upon request, rights to use the Technology Trademarks may be granted by Regional PI Associations.

Terms of use for Certification Trademark

The Certification Trademark* serves:

- To identify products that satisfy the test criteria established by PI and for which PI is issuing product certificates
- To identify experts who have passed successfully an official PROFIBUS and/or PROFINET Installer, PROFIBUS and/or PROFINET Engineer or a PROFI safe Designer course and for which PI is issuing expert certificates in accordance with the "Quality of Services Agreement for PITCs"

The right to use the Certification Trademark related to a product may be issued when the following requirements are met:

- The applicant has the right to use the associated Technology Trademarks
- The applicant possesses a valid certificate from PI for the product

The right to use the Certification Trademark terminates automatically in the event that the product is so modified in any way that it no longer satisfies the established test criteria

The right to use the Certification Trademark related to an expert may be issued when the following requirements are met:

- The applicant possesses a valid expert certificate from PI for one of the above mentioned official courses

The right to use the Certification Trademark terminates automatically in the event that the applicant has given negative statements to the public about PI and/or its technologies without prior consultation or clarification with PI.

Terms of use for Certified by PI Trademark

The Certified by PI Trademark* serves to identify PI Competence Centers (PICC), PI Training Centers (PITC) and PI Test Laboratories (PITL) that fulfill the criteria defined by PI ("Quality of Services Agreement for PICCs", "Quality of Services Agreement for PITCs", "Framework for Testing and Certification of PROFIBUS/PROFINET Products" and "How to become and run an accredited PROFIBUS/PROFINET Test Lab").

The right to use the Certified by PI Trademark may be issued only when the applicant is accredited as PICC, PITC or PITL.

The right to use the Certified by PI Trademark terminates automatically in the event that the applicant has given negative statements to the public about PI and/or its technologies without prior consultation or clarification with PI, and when the accreditation as PICC, PITC or PITL has ended.

* The Certification Trademark and the Certified by PI Trademark are not available for free member download. It will be handed out by PI Business Office directly to qualified companies and/or persons.



Chapter 5: Installation and Setup

5.1	About Installation.	46
5.2	Installation Requirements	47
5.3	Installation Steps	53
5.5	Power Supply Setup	72
5.6	Assembling the Acoustic Stack.	73
5.7	Converter Cooling.	78
5.8	Testing the Installation	80
5.9	Still Need Help?	81

5.1 About Installation

This chapter is intended to help the installer with the basic installation and setup of your new DCX Power Supply F-DP.

CAUTION	Heavy Object
	The power supply, and related components are heavy. Handling, unpacking, and installation may require the assistance of a colleague or the use of lifting platforms or hoists.

International safety-related labels are found on the power supply. Those that are of importance during installation of the system are identified in [Figure 1.1 Safety-related Labels found on the DCX Power Supply F-DP](#).

5.2 Installation Requirements

This section covers the location requirements, mounting options, power supply dimensions, environmental requirements, and electrical requirements, to help you plan and execute your installation successfully.

5.2.1 Location

The DCX Power Supply F-DP comes in two different models Horizontal (benchtop) and Vertical (which may be back mounted or side mounted).

The power supply should be accessible for parameter changes and settings, and it can be placed in a horizontal or vertical orientation (depending on your selected model). The power supply should be located in an area away from radiators or heating vents and positioned so it does not draw in dust, dirt or material via its cooling fan.

The DCX Power Supply F-DP must not be positioned so that is difficult to plug in or unplug the main power plug.

A cable clamp can be used to secure wires in place.

NOTICE	
	Cable clamp is not included with the unit.

Refer to the illustrations on the pages that follow for dimensional drawings of both models. All dimensions are approximate and may vary slightly:

[Figure 5.1 DCX Power Supply F-DP Benchtop Dimensional Drawing.](#)

[Figure 5.2 DCX Power Supply F-DP Vertical Mount Dimensional Drawing \(400 W, 750 W and 800 W\).](#)

[Figure 5.3 DCX Power Supply F-DP Vertical Mount Dimensional Drawing \(1.25 kW and 1.5 kW\).](#)

[Figure 5.4 DCX Power Supply F-DP Vertical Mount Dimensional Drawing \(2.5 kW and 4 kW\).](#)

Figure 5.1 DCX Power Supply F-DP Benchtop Dimensional Drawing

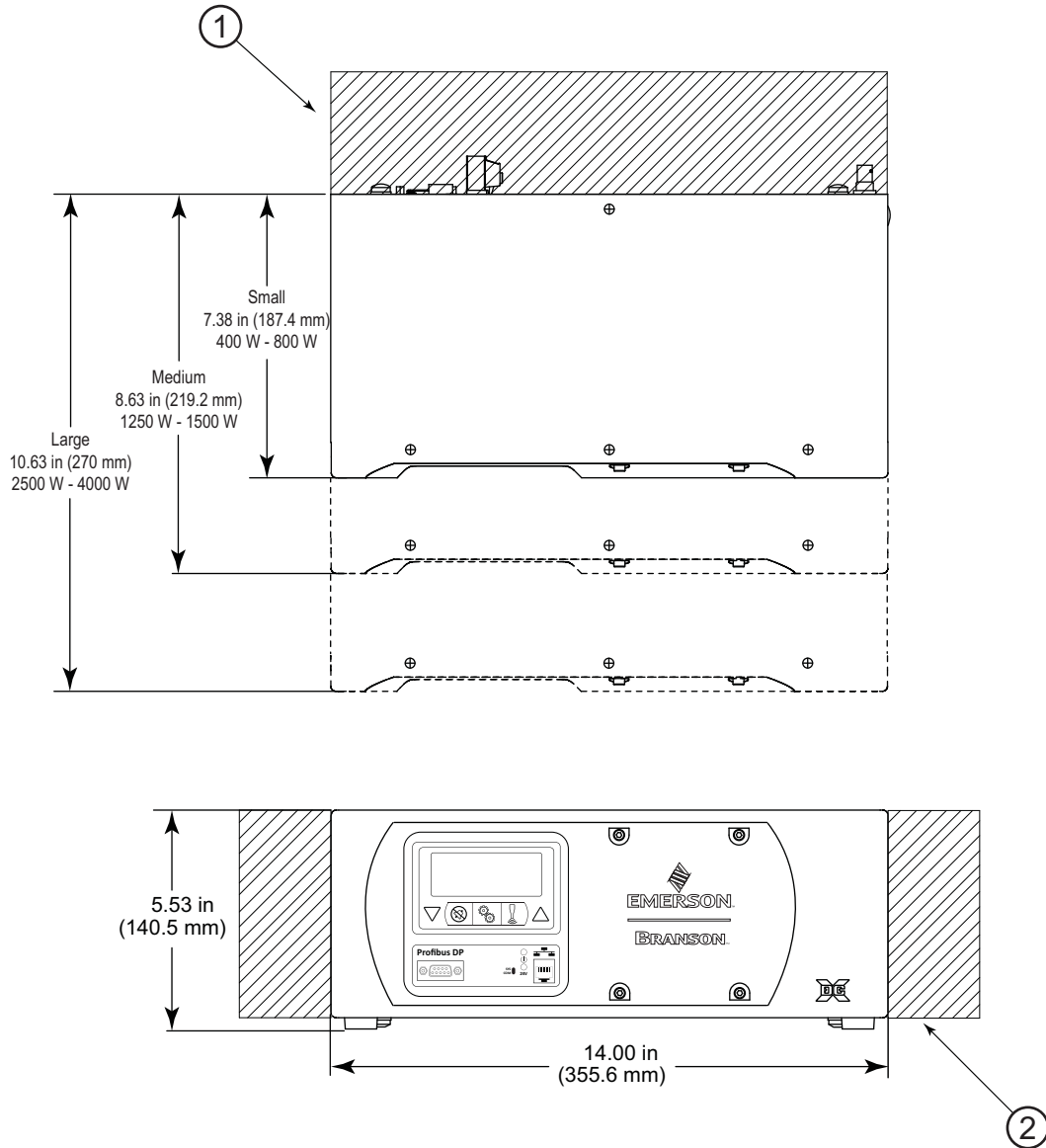

Table 5.1 DCX Power Supply F-DP Benchtop Dimensional Drawing

Item	Note
1	5.0 in (127 mm) recommended clearance for cables.
2	3.0 in (76 mm) recommended fan clearance (both sides).

Figure 5.2 DCX Power Supply F-DP Vertical Mount Dimensional Drawing (400 W, 750 W and 800 W)

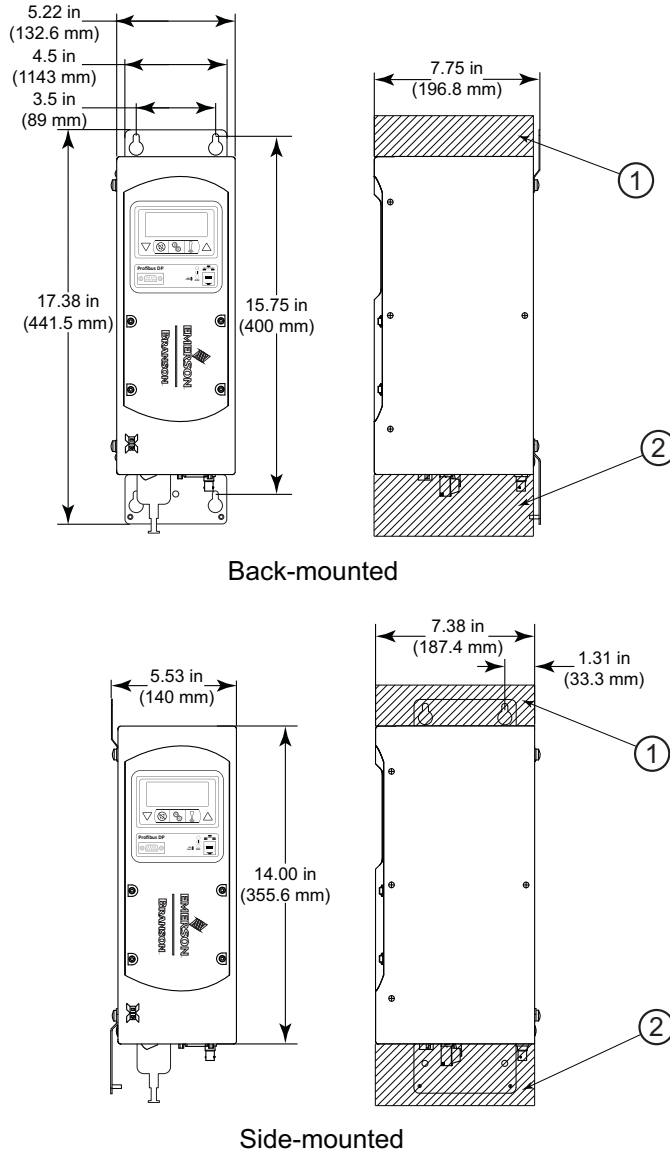

Table 5.2 DCX Power Supply F-DP Vertical Mount Dimensional Drawing (400 W, 750 W and 800 W)

Item	Note
1	3.0 in (76 mm) recommended fan clearance.
2	5.0 in (127 mm) recommended clearance for cables.

NOTICE	
	<p>Use the keyhole mounting bracket to mount the unit in the needed position. Use M6 (6mm) screws to mount the unit.</p>

Figure 5.3 DCX Power Supply F-DP Vertical Mount Dimensional Drawing (1.25 kW and 1.5 kW)

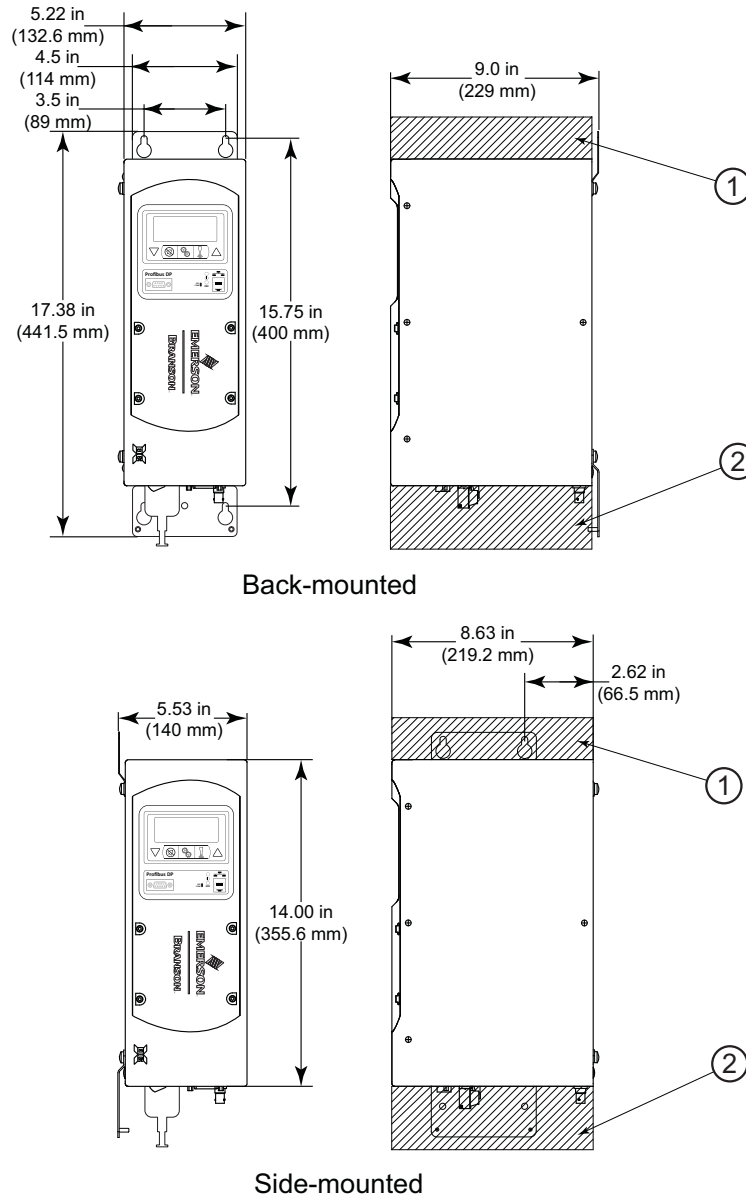

Table 5.3 DCX Power Supply F-DP Vertical Mount Dimensional Drawing (1.25 kW and 1.5 kW)

Item	Note
1	3.0 in (76 mm) recommended fan clearance.
2	5.0 in (127 mm) recommended clearance for cables.

NOTICE	
	<p>Use the keyhole mounting bracket to mount the unit in the needed position. Use M6 (6mm) screws to mount the unit.</p>

Figure 5.4 DCX Power Supply F-DP Vertical Mount Dimensional Drawing (2.5 kW and 4 kW)

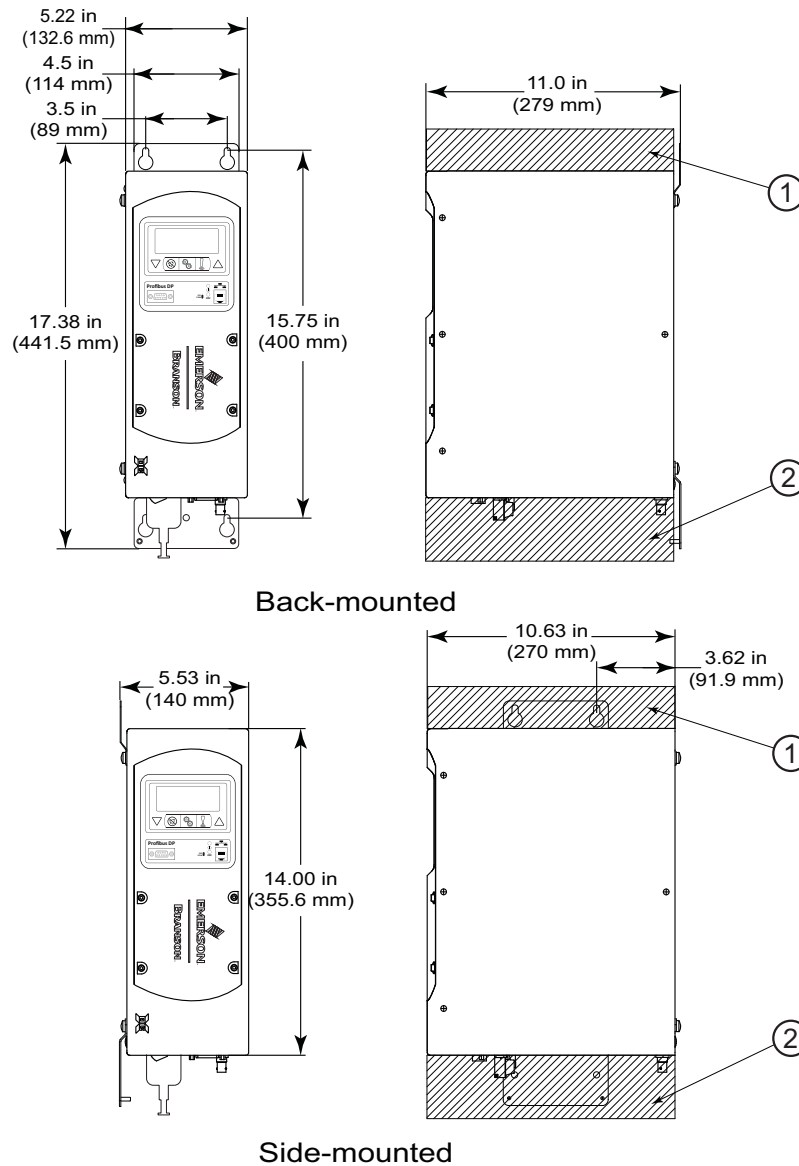



Table 5.4 DCX Power Supply F-DP Vertical Mount Dimensional Drawing (2.5 kW and 4 kW)

Item	Note
1	3.0 in (76 mm) recommended fan clearance.
2	5.0 in (127 mm) recommended clearance for cables.

NOTICE	
	<p>Use the keyhole mounting bracket to mount the unit in the needed position. Use M6 (6mm) screws to mount the unit.</p>

5.2.2 Environmental Requirements

Verify the DCX Power Supply F-DP is operated in an environment that meets the temperature and humidity requirements indicated in [Table 5.5 Environmental Requirements](#).

Table 5.5 Environmental Requirements

Environmental Condition	Acceptable Range
Ambient Operating Temperature	+41° F to +104° F (+5° C to +40° C)
Humidity	Maximum 95%, non-condensing
IP Rating	2X

5.2.3 Electrical Input Power Ratings

Connect the power supply to a single-phase, grounded, 3-wire, 50 Hz or 60 Hz 200 V to 240 V power source. [Table 5.6 Input Current and Circuit Breaker Specifications](#) lists the current and breaker ratings for the various models.

Table 5.6 Input Current and Circuit Breaker Specifications

Model	Power	Current Rating
20 kHz	1250 W	7 A Max. @ 200 - 240 V / 15 A Breaker
	2500 W	14 A Max. @ 200 - 240 V / 25 A Breaker
	4000 W	25 A Max. @ 200 - 240 V / 25 A Breaker
30 kHz	750 W	5 A Max. @ 200 - 240 V / 10 A Breaker
	1500 W	10 A Max. @ 200 - 240 V / 15 A Breaker
40 kHz	400 W	3 A Max. @ 200 - 240 V / 10 A Breaker
	800 W	5 A Max. @ 200 - 240 V / 10 A Breaker

5.2.4 Pneumatic Requirements

Your welding system may require a cooling air stream for the converters. In continuous operations, or applications with longer duty cycles, it may be necessary to cool the horn as well as the converter.

Typically 80 cubic feet (2.26 m³) per hour of clean, dry, compressed air are required to cool most welding operations.

To verify the 80 cubic feet (2.26 m³) per hour cooling air stream required for your welding system, refer to [5.7 Converter Cooling](#).

5.3 Installation Steps

WARNING	High Voltage Hazard
	<p>To prevent the possibility of an electrical shock:</p> <ul style="list-style-type: none"> • Ensure the power source is disconnected before beginning work on line connections • Ensure the power switch on the back of the unit is in the OFF position before making any electrical connections • Always plug the power supply into a grounded power source • To prevent the possibility of an electrical shock, ground the power supply by securing an 8 gauge grounded conductor to the ground screw located next to the air outlet • Ensure power supply installation is performed by qualified personnel and in accordance with local standards and regulations

All persons who are involved with installation, commissioning, operation and maintenance must have the required qualification, strictly follow this operating manual.

Basic installation notes:

- To avoid problems associated with EMI, you should route high power lines (AC and Ultrasonic RF) away from low power lines (controls signals)
- You should consider future troubleshooting and repair when installing all wiring. All wiring should be either color coded or tagged with industrial wire tags
- The minimum cable bend radius is 5 times the cable outer diameter for RF cables
- The minimum cable bend radius is 10 times the cable outer diameter for user I/O & Ethernet cables
- Ground wires should not be shared with other equipment
- All inductive coils must be suppressed with appropriate devices, such as diodes or RC networks

Mount the Power Supply

The cable lengths are limited based on the operating frequency of the welding system. Performance and results can suffer if the RF cable is crushed, pinched, damaged or modified. Contact your Branson Representative if you have special cable requirements.

Do not place the power supply on the floor or in other locations that will allow dust, dirt or contaminants to be drawn into the power supply.

NOTICE	
	<p>Special fan filter kits are available for use in dusty environments. See Table 9.12 Other Items used with the DCX Power Supply F-DP.</p>

NOTICE	
	<p>Do not block exhaust and intake air circulation, which is needed to maintain a safe operating temperature.</p>

5.3.1 Horizontal (Benchtop) Mounting

The Horizontal DCX Power Supply F-DP is designed to be placed on a workbench (rubber feet on bottom) within cable-length limits of the stack. It has one fan which draws cooling air from the left side to the right side, which must be free from obstruction. The controls on the front of the power supply should be accessible and readable for setup changes.

All electrical connections are made to the rear of the power supply, which should be positioned in your workspace with adequate clearance, approximately 3 in (76.2 mm) or more on either side, and 5 in (127 mm) to the rear) for cable access and ventilation. Do not place anything on top of the power supply case.

For a dimensional drawing of the Horizontal DCX Power Supply F-DP, see [Figure 5.1 DCX Power Supply F-DP Benchtop Dimensional Drawing](#).

5.3.2 Vertical Mounting

The Vertical DCX Power Supply F-DP is designed to be mounted vertically (from the side or back) within cable-length limits of the stack. It has one fan which draws cooling air from the top to the bottom of the power supply, which must be free from obstruction. The controls on the front of the power supply should be accessible and readable for setup changes.

All electrical connections are made to the bottom of the power supply, which should be positioned with adequate clearance (approximately 3 in (76.2 mm) or more on the top, and 5 in (127 mm) to the bottom) for cable access and ventilation. Do not place anything on top of the power supply case.

For dimensional drawings of the Vertical DCX Power Supply F-DP, see [Figure 5.2 DCX Power Supply F-DP Vertical Mount Dimensional Drawing \(400 W, 750 W and 800 W\)](#), [Figure 5.3 DCX Power Supply F-DP Vertical Mount Dimensional Drawing \(1.25 kW and 1.5 kW\)](#) and [Figure 5.4 DCX Power Supply F-DP Vertical Mount Dimensional Drawing \(2.5 kW and 4 kW\)](#).

5.3.3 Mounting Considerations

In addition to the considerations mentioned above, the LCD's viewing angle should be taken into account when selecting a location for your DCX Power Supply F-DP. The LCD is designed to be viewed from the top. Please refer to [Figure 5.5 LCD Viewing Angle](#) below when selecting a location for your DCX Power Supply F-DP.

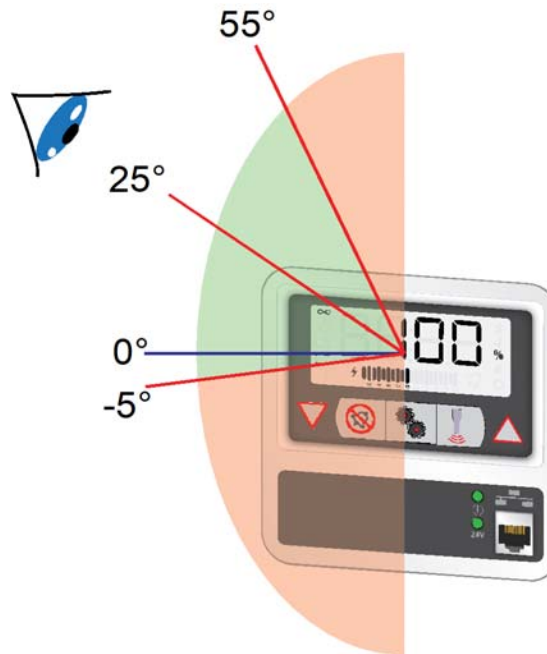
Figure 5.5 LCD Viewing Angle

NOTICE	
	Optimal viewing angle is 25° above the normal to the display (indicated by 0°).

5.4 Electrical Connections

Figure 5.6 DCX Power Supply F-DP Connections (Horizontal Model)

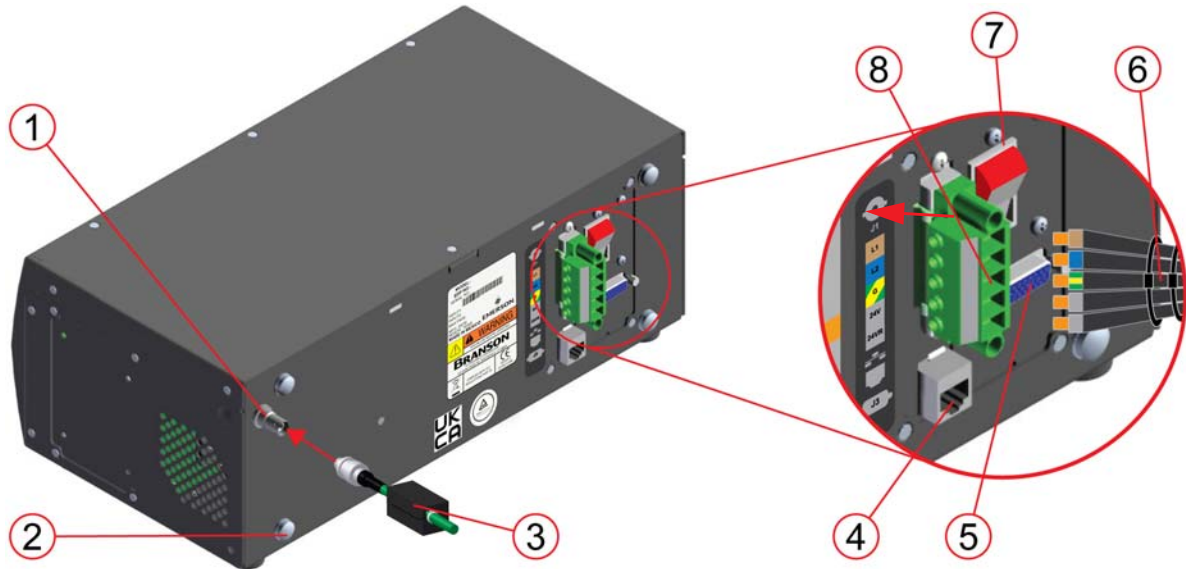

Table 5.7 DCX Power Supply F-DP Connections (Horizontal Model)

Item	Description
1	RF Connector
2	Ground Screw
3	RF Cable (Ferrite End)
4	Ethernet Port
5	User I/O Connectors
6	Line Cord
7	Circuit Breaker (On/Off Switch)
8	Input Power Connector

Figure 5.7 DCX Power Supply F-DP Connections (Vertical Model)

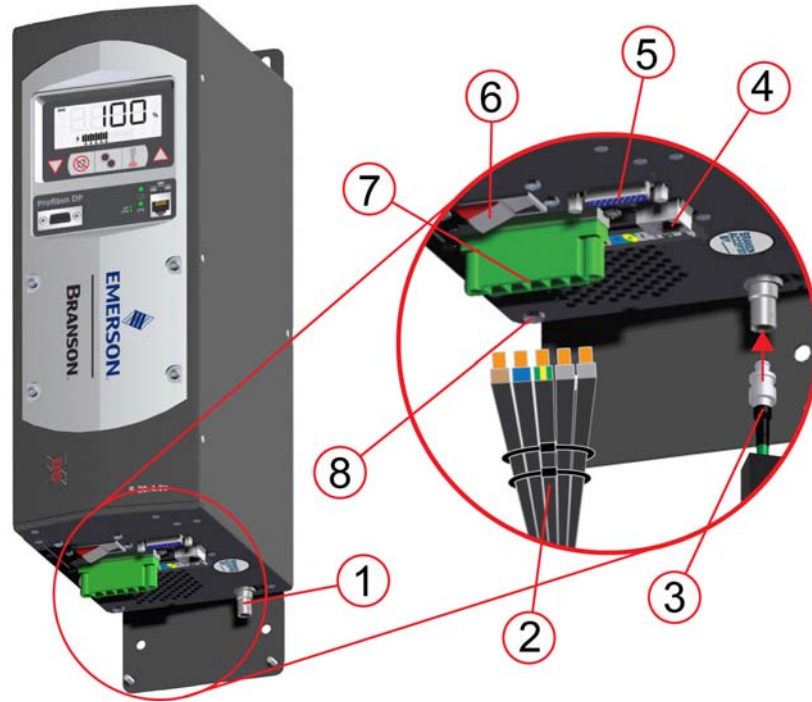



Table 5.8 DCX Power Supply F-DP Connections (Vertical Model)

Item	Description
1	RF Connector
2	Line Cord
3	RF Cable (Ferrite End)
4	Ethernet Port
5	User I/O Connectors
6	Circuit Breaker (On/Off Switch)
7	Input Power Connector
8	Ground Screw

5.4.1 User I/O Connections

NOTICE	
	User I/O interface is only available in manual mode.

The user I/O is a standard interface for automation, provided on the power supply. It provides the ability to make your own interface for your automation, actuator interface, special control, or reporting needs. The interface cable has a 26-pin HD male D-Sub connector on one end, and wires on the other end. Pins are wired to ICEA standard color code (see [Figure 5.8 User I/O Cable Identification and Wire Color Diagram](#) and [Table 5.10 User I/O Cable Pin Assignments](#)).

NOTICE	
	Ensure all unused wires are properly isolated. Failure to do so, may result in a power supply malfunction.

Digital I/O functions can be configured to either active-high or active-low using the DCX Power Supply F-DP Web Page Interface. [Table 5.11 Digital Input Functions](#) to [Table 5.14 Analog Output Functions](#) list the input and output functions available on the DCX Power Supply F-DP. See [Table 5.15 Default Branson User I/O Connector PIN Assignments, V6.0](#) for the default user I/O pin assignments.

[Figure 5.9 Typical Digital I/O Wiring Examples](#) and [Figure 5.10 Typical Analog I/O Wiring Examples](#) show typical wiring examples.

Figure 5.8 User I/O Cable Identification and Wire Color Diagram

User I/O Cable

Stripped Jacket one end,

HD-26 male connector other end

(cable length as ordered)

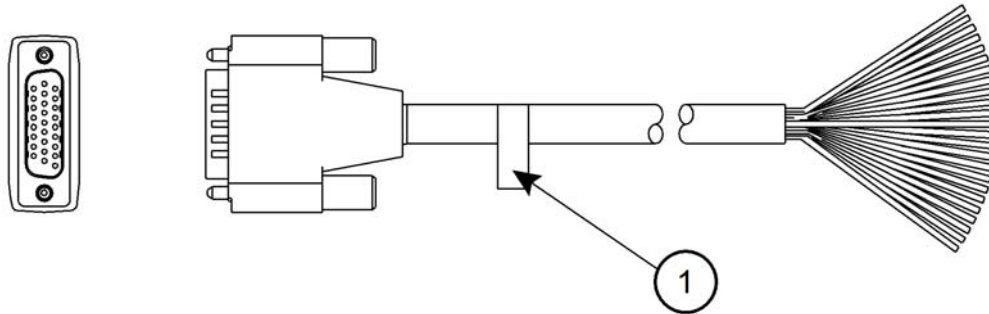

Wire Color Diagram

Two Colors = Insulator/Stripe

Three Colors = Insulator/Stripe/Dot

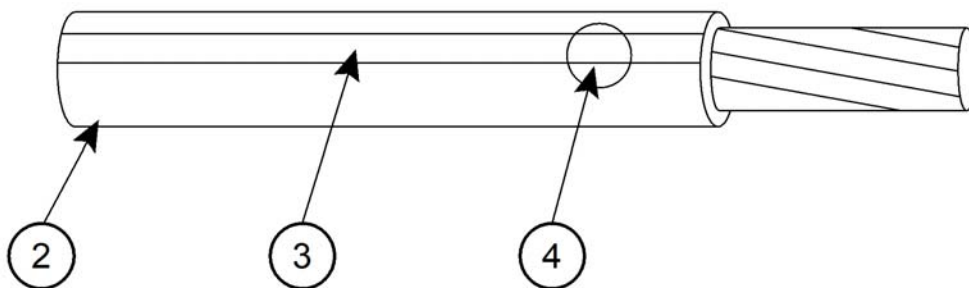

Table 5.9 User I/O Cable Identification and Wire Color Diagram

Item	Description
1	Part number
2	Insulation
3	Stripe
4	Dot

5.4.2 User I/O Cable Pin Assignments

Table 5.10 User I/O Cable Pin Assignments

Pin	Input/Output (All I/O are user definable)	Available Function	Signal Type	Signal Range	Color
1	Digital in 1*	See Table 5.11 Digital Input Functions	Discrete Input	0 V to 24 V +/- 10%, 12 mA	Blk
2	Digital in 2*				Wht
3	Digital in 3*				Red
4	Digital in 4*				Grn
5	+24 V	N/A	24 V Source	24 V +/-10%, 250 mA Max	Orn
6					Blu
7	Digital out 1	See Table 5.12 Digital Output Functions	Discrete Output	0 V to 24 V, -10%, 25mA Max	Wht/Blk
8	Digital out 2				Red/Blk
9	Digital out 3				Grn/Blk
10	Digital out 4				Orn/Blk
11	Digital in 5*	See Table 5.11 Digital Input Functions	Discrete Input	0 V to 24 V +/- 10%, 12 mA	Blu/Blk
12	Digital in 6*				Blk/Wht
13	Digital in 7*				Red/Wht
14	GND	N/A	24 V Ground	0 V	Grn/Wht
15					Blu/Wht
16	Digital in 8*	See Table 5.11 Digital Input Functions	Discrete Input	0 V to 24 V +/- 10%, 12 mA	Blk/Red
17	Analog in 1	See Table 5.13 Analog Input Functions	Analog Input	0 V to +10 V, 2 mA	Wht/Red
18	Analog in 2				Orn/Red
19	Digital out 5	See Table 5.12 Digital Output Functions	Discrete Output	0 V to 24 V +/- 10%, 12 mA Max	Blu/Red
20	Digital out 6				Red/Grn
21	Digital out 7				Orn/Grn
22	Digital out 8				Blk/Wht/Red

Table 5.10 User I/O Cable Pin Assignments

Pin	Input/Output (All I/O are user definable)	Available Function	Signal Type	Signal Range	Color
23	Digital in 9*	See Table 5.11 Digital Input Functions	Discrete Input	0 V to 24 V +/- 10%, 12 mA	Wht/Blk/Red
24	Analog out 1	See Table 5.14 Analog Output Functions	Analog Output	0 V to 10 V +/- 5%, 1 mA Max	Red/Blk/Wht
25	Analog out 2				Grn/Blk/Wht
26	Analog GND	N/A	Analog Ground	0 V	Orn/Blk/Wht

*Input signal should be kept at least 5ms.

5.4.3 Digital Input Functions

Table 5.11 Digital Input Functions

Function	Description
ACT-Actuator Present	Must be active at power up to activate TRS, ULS, Interlock, Part in Place.
ACT-Cycle Abort	Will immediately terminate the current weld cycle and not accept another External Start until removed. Reset required is user settable.
ACT-Ground Detect	Will start scrub time. When scrub time expires, ultrasonics will be turned off.
ACT-Interlock In Place	Prevents a cycle from starting until the signal becomes active.
ACT-Part In Place	When enabled, signal must be active before weld cycle is started.
ACT-Trigger Switch (TRS)	Indicates the power supply to start ultrasonics.
ACT-Upperlimit Switch (ULS)	Tells the power supply that the actuator is at home position.
RF-Feedback A, B, C, D	Indicates which relay the RF switch has changed to. Bit 0 to bit 3 are binary coded values indicating the selected RF switch. It can also be uncoded. This function is user settable.
RF-Status Feedback	Indicates the RF switch has changed to the proper relay. NOTICE Single value. Not coded/uncoded like RF-Feedback A, B, C, D.

Table 5.11 Digital Input Functions

Function	Description
STD-Cable Detect	When enabled 24 volts must be present on pin at all times. If 24 volts is removed, suggesting that the cable has been removed, ultrasonics will not be allowed to run and will stop if already running.
STD-Display Lock	Locks the front panel display controls. Registers are read only when signal is active.
STD-External Amp Step Trigger	When set to +24 V sets amplitude to Amplitude 2. If set again to 0 V during a weld cycle will set amplitude back to Amplitude 1. Used only if amplitude stepping is turned on and set to external input.
STD-External Horn Scan	Starts horn scan. Signal must be maintained during the scan.
STD-External Reset	Resets alarm conditions.
STD-External Seek	Activates ultrasonic energy at 10% amplitude for the purpose of finding the ultrasonic stack resonant frequency.
STD-External Sonics Delay	Delays the start of ultrasonics even if a trigger occurs. This can be used to enable an external operation to be complete before continuing the cycle (e. g. test device or part marking operation). If the delay is maintained for 1 minute, the cycle is aborted and all inputs must be cycled again.
STD-External Start	<p>Activates ultrasonic energy at the currently set amplitude.</p> <p>NOTICE DCX Power Supply F-DP must be in ready mode before External Start.</p> <p>WARNING When using 0 V to activate ultrasonics (External Start signal), it is recommended to assign one input as Cable Detect to prevent sonics from activating if 24 V is lost by accident.</p>
STD-External Test	Performs a test cycle. Signal must be maintained.
STD-Load New Preset	Loads a weld preset as defined by Recall Preset Bits 1-32.
STD-Memory Clear	Centers the power supply start frequency.
STD-Recall Preset 1, 2, 4, 8, 16, 32	Bit 0 to bit 5 for preset recall binary code. This code will be used to recall a preset when Load Preset input is activated.
STD-Sonics Disable	Prevents ultrasonics from coming on. If active throughout a weld cycle, the cycle will be performed but without ultrasonics. Should the weld mode be time indeterminate (energy, power, etc) then the weld time will extend to the cutoff time.
STD-Start Cycle	Starts a cycle.

5.4.4 Digital Output Functions

Table 5.12 Digital Output Functions

Function	Description
ACT-Actuator Home	Indicates that a ULS input has been received.
ACT-Afterburst Delay	Indicates if the weld cycle is in the Afterburst Delay state.
ACT-Afterburst Time	Indicates if the weld cycle is in the Afterburst state.
ACT-End of Hold Time	Indicates the system has reached the end of Hold since the cycle started.
ACT-Holdtime	Indicates if the weld cycle is in the Hold Time state.
RF-Select A-D	Output to select stacks 1 to 4 or a binary coded value (bit 0-3) to select RF relay.
STD-Amp1 Amp2	If output is 0 V, indicates the amplitude setting is Amplitude 1. If output is 24 V, indicates the amplitude setting is Amplitude 2.
STD-Confirm Preset Change	Output will go active when a preset has been recalled.
STD-Custom Alarm	Indicates a Custom Alarm has occurred. This function is user defined.
STD-Cycle Okay	Output will go inactive with cycle start input, and will go high at the end of the cycle if no alarms occurred.
STD-Cycle Start Out	Indicates start signal is active. It will stay active through weld time and hold time.
STD-General Alarm	Indicates an alarm occurred. This function is user configurable.
STD-Minus Energy Limit Alarm	Indicates the weld did not reach the minimum energy set.
STD-Minus Time Limit Alarm	Indicates the weld time has not reached the minimum time set.
STD-Minus Peakpower Limit Alarm	Indicates the weld has not reached the minimum peak power set.
STD-Overload Alarm	Indicates an overload alarm has occurred.
STD-Plus Energy Limit Alarm	Indicates the weld has exceeded the maximum energy set.

Table 5.12 Digital Output Functions

Function	Description
STD-Plus Time Limit Alarm	Indicates the weld time did exceed the maximum time set.
STD-Plus Peakpower Limit Alarm	Indicates the weld has exceeded the maximum peak power set.
STD-Ready	If active, indicates the system is ready to start a weld cycle, enter test mode, or start a horn scan. If inactive, it indicates the system is already cycling, in test mode, performing a horn scan, or has a reset-required alarm.
STD-Seek/Scan Out	Indicates either a seek or a horn scan is in progress.
STD-Sonics Active	Indicates sonics are active.
STD-Start Signal Release	If output is active, it indicates the start signal can be removed, If output is inactive, it indicates start signal is either inactive or that it cannot yet be removed.
STD-Status	To be used to drive an external beeper. Single 0.5 second beeps will occur when trigger is received. Three Beeps indicate an alarm occurred (e.g. overload alarm). Beeps 0.5 seconds on, 0.5 seconds off long are in between each beep.
STD-Weldcycle Complete	Indicates if a weld cycle is no longer in process.

5.4.5 Analog Input Functions

Table 5.13 Analog Input Functions

Function	Description	Valid Range
Amplitude In	Controls the amplitude of ultrasonic energy that will be delivered by the power supply.	1 V to 10 V* (10% to 100%)
Custom Input 1, 2	Define an analog voltage that can be used to create a cutoff. Voltage must be exceeded to produce the cutoff.	0 V to 10 V

Table 5.13 Analog Input Functions

Function	Description		Valid Range
Frequency Offset	Controls the frequency offset to the power supply operating frequency. Actual offset depends on the power supply operating frequency:		1 V to 9 V* (5 V is zero offset)
	Frequency	Offset Range	
	20 kHz	+/- 400 Hz	
	30 kHz	+/- 600 Hz	
	40 kHz	+/- 800 Hz	

* If the input signals are not within their valid range, or if left unconnected, the power supply will use 50% amplitude and zero frequency offset, respectively.

5.4.6 Analog Output Functions

Table 5.14 Analog Output Functions

Function	Description			Valid Range
Amplitude Out	Provides a 0 V to 10 V output signal proportional to amplitude (0% to 100%).			0 V to 10 V (0% to 100%)
Power Out	Provides a 0 V to 10 V output signal proportional to ultrasonic power output (0% to 100%).			0 V to 10 V (0% to 100%)
Frequency Out	Provides a 0 V to 10 V output signal that indicates memory plus offset. Actual frequency depends on the power supply operating frequency:			0 V to 10 V (5 V is zero offset)
	Frequency	Lower Limit (0 V)	Upper Limit (10 V)	
	20 kHz	19,450 Hz	20,450 Hz	
	30 kHz	29,250 Hz	30,750 Hz	
	40 kHz	38,900 Hz	40,900 Hz	

5.4.7 Default Branson User I/O Connector PIN Assignments Software V6.0 - V6.4

Table 5.15 Default Branson User I/O Connector PIN Assignments, V6.0

Pin	Function	I/O Type	Values
1	STD-External Start	Input Digital	Apply +24 VDC to run cycle NOTICE DCX Power Supply F-DP must be in ready mode before External Start.
2	STD-External Seek	Input Digital	Apply +24 VDC to perform a seek
3	STD-External Reset	Input Digital	Apply +24 VDC to reset alarm
4	STD-Memory Clear	Input Digital	Apply +24 VDC to clear memory
5 6	+24 VDC Source	I/O Signal Source	+24 V, 250 mA max. (sourced from the customer supplied 24 V external power supply).
7	STD-Ready	Output Digital	+24 V indicates the system is ready
8	STD-Sonics Active	Output Digital	+24 V indicates ultrasonics are active
9	STD-General Alarm	Output Digital	+24 V indicates an alarm occurred
10	STD-Seek/Scan Out	Output Digital	+24 V indicates either Seek or a Scan is in progress
11	STD-Recall Preset 1	Input Digital	Bit 0 for preset recall binary code
12	STD-Recall Preset 2	Input Digital	Bit 1 for preset recall binary code
13	STD-Recall Preset 4	Input Digital	Bit 2 for preset recall binary code
14 15	+24 VDC Return and I/O Return	I/O Signal Return	Return for all pins except pins 17, 18, 24, and 25
16	STD-Recall Preset 8	Input Digital	Bit 3 for preset recall binary code
17	Amplitude In	Input Analog	1 V to + 10 V (10% to 100%)*
18	Frequency Offset	Input Analog	1 V to + 9 V (5 V is zero offset)
19	STD-Amp1 Amp2	Output Digital	Indicates amplitude setting 0 V for Amplitude 1, +24 V for Amplitude 2
20	STD-Overload Alarm	Output Digital	+24 V indicates an overload alarm occurred.
21	STD-Start Signal Release	Output Digital	+24 V indicates start signal can be removed.
22	STD-Confirm Preset Change	Output Digital	+24 V indicates a load new preset request has occurred and the preset was successfully recalled.

Table 5.15 Default Branson User I/O Connector PIN Assignments, V6.0

Pin	Function	I/O Type	Values
23	ACT-Trigger Switch	Input Digital	+24 V must be present for ultrasonics to be enabled.
24	Power Out	Output Analog	0 V to + 10 V (0% to 100%)
25	Amplitude Out	Output Analog	0 V to + 10 V (0% to 100%)
26	Analog Signal Return	Analog Signal Return	Return for pins 17, 18, 24, and 25

* If the input signals are not within their valid range, or if left unconnected, the power supply will use 50% amplitude and zero frequency offset, respectively.

Software V6.5 or Newer

Table 5.16 Default Branson User I/O Connector PIN Assignments, V6.5

Pin	Function	I/O Type	Values
1	STD-External Start	Input Digital	Apply +24 VDC to run cycle NOTICE DCX Power Supply F-DP must be in ready mode before External Start.
2	STD-External Seek	Input Digital	Apply +24 VDC to perform a seek
3	STD-External Reset	Input Digital	Apply +24 VDC to reset alarm
4	STD-Memory Clear	Input Digital	Apply +24 VDC to clear memory
5	+24 VDC Source	I/O Signal Source	+24 V, 250 mA max. (sourced from the customer supplied 24 V external power supply).
6			
7	STD-Ready	Output Digital	+24 V indicates the system is ready
8	STD-Sonics Active	Output Digital	+24 V indicates ultrasonics are active
9	STD-General Alarm	Output Digital	+24 V indicates an alarm occurred
10	STD-Seek/Scan Out	Output Digital	+24 V indicates either Seek or a Scan is in progress
11	STD-Recall Preset 1	Input Digital	Bit 0 for preset recall binary code
12	STD-Recall Preset 2	Input Digital	Bit 1 for preset recall binary code
13	ACT-Ground Detect	Input Digital	Bit 2 for preset recall binary code
14	+24 VDC Return and I/O Return	I/O Signal Return	Return for all pins except pins 17, 18, 24, and 25
15			

Table 5.16 Default Branson User I/O Connector PIN Assignments, V6.5

Pin	Function	I/O Type	Values
16	ACT-Cycle Abort	Input Digital	Bit 3 for preset recall binary code
17	Amplitude In	Input Analog	1 V to + 10 V (10% to 100%)*
18	Frequency Offset	Input Analog	1 V to + 9 V (5 V is zero offset)
19	STD-Confirm Preset Change	Output Digital	Indicates amplitude setting 0 V for Amplitude 1, +24 V for Amplitude 2
20	STD-Overload Alarm	Output Digital	+24 V indicates an overload alarm occurred.
21	STD-Plus Peak Power Limit Alarm	Output Digital	+24 V indicates start signal can be removed.
22	STD-Minus Peak Power Limit Alarm	Output Digital	+24 V indicates a load new preset request has occurred and the preset was successfully recalled.
23	STD-Display Lock	Input Digital	+24 V must be present for ultrasonics to be enabled.
24	Power Out	Output Analog	0 V to + 10 V (0% to 100%)
25	Amplitude Out	Output Analog	0 V to + 10 V (0% to 100%)
26	Analog Signal Return	Analog Signal Return	Return for pins 17, 18, 24, and 25

* If the input signals are not within their valid range, or if left unconnected, the power supply will use 50% amplitude and zero frequency offset, respectively.

5.4.8 Typical Digital I/O Wiring Examples

Figure 5.9 Typical Digital I/O Wiring Examples

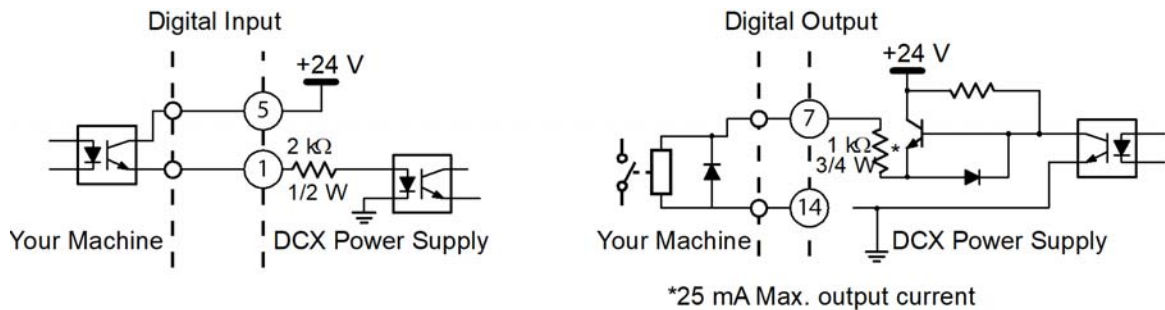

5.4.9 Typical Analog I/O Wiring Examples

Figure 5.10 Typical Analog I/O Wiring Examples

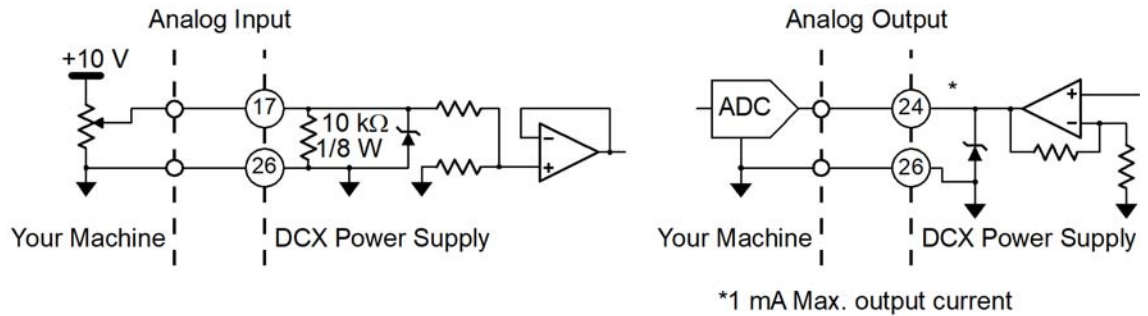

5.4.10 Output Power (RF Cable) Connection

Ultrasonic energy is delivered to the SHV connector on the power supply, which is then transmitted to the converter via the RF cable. The RF connector position depends on the power supply configuration. For Horizontal models it is located on the rear panel of the power supply. For Vertical models it is located on the bottom panel of the power supply.

To reduce electromagnetic interference (EMI), RF cables are equipped with a ferrite core (plastic case) on one end. This end is meant to be connected to the power supply.



WARNING	High Voltage Hazard
	Operating the System with the RF Cable disconnected or damaged can present an electrical shock hazard.
WARNING	High Voltage Hazard
	To avoid the possibility of electrical shock. Converters need to be properly grounded.
NOTICE	
	To avoid the possibility of EMI interference, ensure the RF connection to the power supply is made with the cable end that has the ferrite core box attached (see Figure 5.11 RF Cable Connection).

Figure 5.11 RF Cable Connection

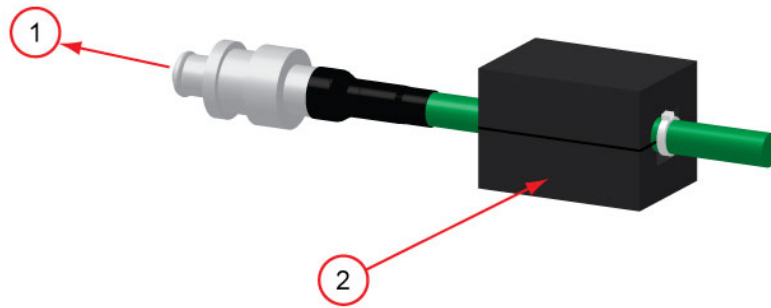





Table 5.17 RF Cable Connection

Item	Description
1	To Power Supply
2	Ferrite Core Box

5.4.11 Input Power Connection

WARNING	High Voltage Hazard
	<p>Ensure all electrical power is off when wiring input power to your DCX Power Supply F-DP connector block.</p> <p>To prevent the possibility of an electrical shock, ground the power supply by securing an 8 gauge grounded conductor to the ground screw located next to the air outlet.</p>
WARNING	High Voltage Hazard
	<p>If miss-wired, the power supply can present an electrical shock hazard.</p>
NOTICE	
	<p>The power supply can be permanently damaged if it is connected to the incorrect line voltage, or if the connection is mis-wired.</p>

Use the following procedure to connect the power supply to a 24 VDC 2.5A external power supply and to a single-phase, grounded 3-wire, 50 Hz or 60 Hz 200 V to 230 V power source. The 24 VDC power supply must be safety certified and agency approved.

Table 5.18 Input Power Connection

Step	Action
1	Detach the connector block on the back of the power supply.
2	Use two properly sized wires (according to local standards) to connect a 24 VDC 2.5A power supply as shown on Figure 5.6 DCX Power Supply F-DP Connections (Horizontal Model) .
3	Use three properly sized wires (No. 12 gauge, 2.5 mm or according to local standards) to connect the line 1, line 2, and ground to the connector block as shown on Figure 5.6 DCX Power Supply F-DP Connections (Horizontal Model) . Choose wires according to the current rating as specified in Table 5.6 Input Current and Circuit Breaker Specifications and on the label located on the back of the unit. Be sure to use agency approved wiring and use sleeving or tubing on each wire for double insulation.
4	Secure an 8 gauge grounded conductor to the ground screw located next to the air outlet.
5	Connect the converter-booster-horn stack to the power supply using the RF cable. See 5.4.10 Output Power (RF Cable) Connection .
6	Ensure the power switch on the back of the unit is in the OFF position. Plug the connector block back into the power supply. Tighten the two securing screws.
7	Connect the power supply to a single-phase, grounded, 3-wire, 50 Hz or 60 Hz 200 V to 230 V power source.

5.5 Power Supply Setup

Certain power supply configurations can be modified from the factory setting if needed. Although not usually requiring modifications from the factory setting, the following features are selectable:

- **Afterburst:** Allows for a short activation of ultrasonics at the end of the weld cycle to reliably release parts from the horn
- **Cutoffs:** Allows for setting parameter values for immediately terminating a weld cycle: Time (S); Energy (J); Peak Power (%); Frequency Low (Hz); Frequency High (Hz); Custom Input1 (V); and Custom Input2 (v)
- **End of Weld Store:** Provides an option for selecting if the stack frequency is stored at the end of each weld cycle
- **Energy Brake:** Allows the user to set the power supply to reduce the amplitude before the sonics are shut off
- **Frequency Offset:** Allows for varying the start frequency by way of external controls (analog signal applied through the user I/O analog input) or setting a fixed value using the web page interface. This is useful for certain applications, where the force applied on the fixture or anvil causes a frequency shift in the stack's operation
- **Limits:** Allows for setting up limits within a weld mode: +/- Continuous; +/- Time (s); +/- Energy (J); or +/- Peak Power (%)
- **Mode:** Allows for selecting the weld mode from the different available options: Continuous; Time (s); Energy (J); Peak Power (%); and Ground detect
- **Power Up:** Allows an option to configure the power supply to perform a seek on power up; a horn scan on power up; or to perform no action at power up
- **Seek Ramp:** Provides a selection for different power supply seek ramp times
- **Seek Time:** Provides an option for selecting seek duration
- **Start Ramp:** Provides a selection for different start ramp times. This controls how fast the amplitude of the horn rises from 0 to 100. Long ramp times may be useful when using large horns or high gain stacks
- **Timed Seek:** Provides an option for monitoring, and storing the operating frequency at timed intervals (60 seconds). Periodic frequency seeks may be helpful when welder is not used for long periods of time. Seeks are timed from the moment sonics was last activated
- **Weld Amplitude:** Allows for varying the amplitude (10% to 100%) using the front panel LCD, the web page interface, or by way of external controls (analog signal applied through the user I/O analog input). Via the web page interface scrub amplitude, afterburst amplitude, and amplitude stepping options may also be configured

For instruction on how to change the power supply settings refer to [7.4 Configuring the Power Supply Registers](#) in [Chapter 7: Operation](#).

5.6 Assembling the Acoustic Stack



CAUTION	General Warning
	<p>The following procedure must be performed by a setup person. If necessary, secure the largest portion of a square or rectangular horn in a soft jawed vise. NEVER attempt to assemble or remove a horn by holding the converter housing or the booster clamp ring in a vise.</p>
CAUTION	General Warning
	<p>Do not use silicone grease with Mylar plastic film washers. Use only 1 (one) Mylar plastic film washer of the correct inside and outside diameters at each interface.</p>
NOTICE	
	<p>The use of a Branson torque wrench or the equivalent is recommended. P/N 101-063-787 for 20 kHz, and 30 kHz systems and 101-063-618 for 40 kHz systems.</p>

Figure 5.12 Assembling the Acoustic Stack



Acoustic Stack Description

Table 5.19 Acoustic Stack Description

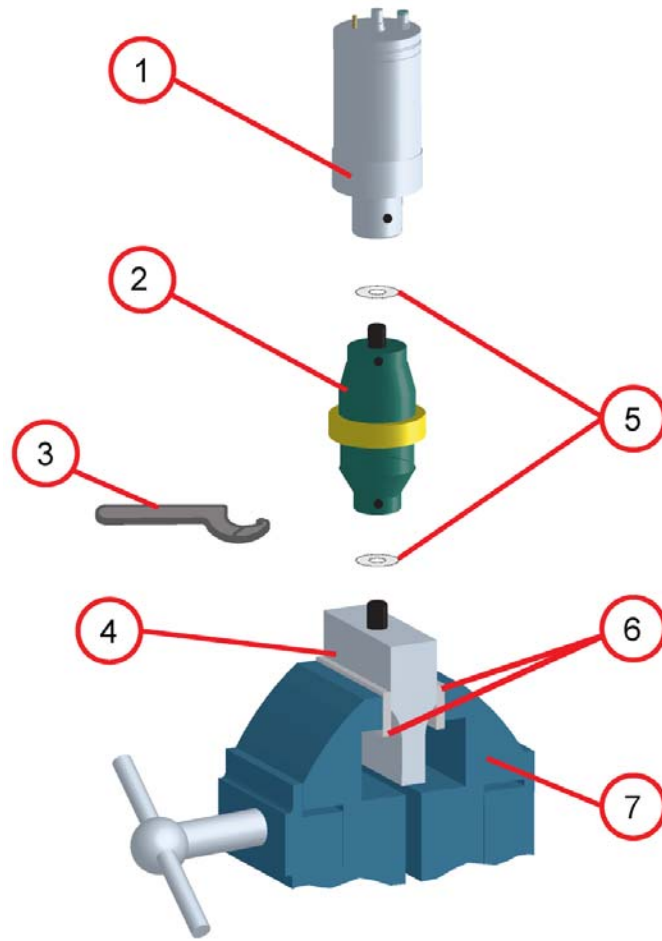
Item	Description
1	Converter
2	Booster
3	Spanner (provided)
4	Horn
5	See stack assembly procedure
6	Vise Jaw protectors (aluminum or soft metal)
7	Vise

Stack Torque Values

Table 5.20 Stack Torque Values

Frequency	Torque
20 kHz	220 in·lb (24.85 N·m)
30 kHz	185 in·lb (21 N·m)
40 kHz	95 in·lb (10.73 N·m)

Tools

Table 5.21 Tools

Tool	EDP Number
20 kHz, and 30 kHz Torque Wrench Kit	101-063-787
40 kHz Torque Wrench	101-063-618
20 kHz Spanner Wrench	101-118-039
30 kHz Spanner Wrench	201-118-033
40 kHz Spanner Wrench	201-118-024
Silicone Grease	101-053-002
Mylar Plastic Film Washers (20 kHz)	100-063-357
Mylar Plastic Film Washers (30 kHz)	100-063-632

5.6.1 For a 20 kHz System

Table 5.22 20 kHz System

Step	Action
1	Ensure that the mating surfaces of the converter, booster, and horn are clean, and that the threaded holes are free of foreign material.
2	Install a single Mylar plastic film washer (matching the size of the washer to the stud) to each interface.
3	Assemble the converter to the booster and the booster to the horn.
4	Torque to 220 in·lb (24.85 N·m) at each interface.

5.6.2 For a 30 kHz System

Table 5.23 30 kHz System

Step	Action
1	Ensure that the mating surfaces of the converter, booster, and horn are clean, and that the threaded holes are free of foreign material.
2	Install a single Mylar plastic film washer (matching the size of the washer to the stud) to each interface.
3	Assemble the converter to the booster and the booster to the horn.
4	Torque to 185 in·lb (21 N·m) at each interface.

5.6.3 For a 40 kHz System

Table 5.24 40 kHz System

Step	Action
1	Ensure that the mating surfaces of the converter, booster, and horn are clean, and that the threaded holes are free of foreign material.
2	Coat each interface surface with a thin film of silicon grease - but do not apply silicon grease to a threaded stud or tip.
3	Assemble the converter to the booster and the booster to the horn.
4	Torque to 95 in·lb (10.73 N·m) at each interface.

5.6.4 Connecting Tip to Horn

1. Ensure that the mating surfaces of the tip and horn are clean. Remove any foreign matter from the threaded stud and hole.
2. Hand assemble the tip to the horn. Assemble dry. Do not use any silicone grease.
3. Use the spanner wrench and an open-end wrench (refer to [Figure 5.13 Connecting Tip to Horn](#)) and tighten to the following torque tip specifications:

Figure 5.13 Connecting Tip to Horn

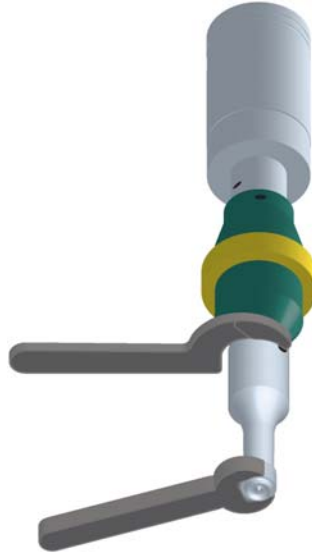

Table 5.25 Tip to horn torque values

Tip Thread	Torque
1/4 - 28	110 in·lbs (12.42 N·m)
3/8 - 24	180 in·lbs (20.33 N·m)

5.7 Converter Cooling

Converter performance and reliability can be adversely affected if the converter ceramics are subjected to temperatures above 140° F (60° C). The converter front driver temperature should not exceed 122° F (50° C).

To prolong converter life and maintain a high degree of system reliability, the converter should be cooled with clean, dry, compressed air, particularly if your application calls for continuous ultrasonic operation. Converter cooling is especially critical in 40 kHz applications.

Use one of the following procedures to determine if a converter is operating close to the maximum allowable temperature. Check converter temperature immediately after substantial machine operation and without power applied to the horn.

- Press a pyrometer probe (or similar temperature measuring device) against the front driver of the converter assembly. Wait for the probe to reach the temperature of the shell. If the temperature is 120° F (49° C) or higher, the converter requires a cooling air stream
- If a temperature measuring device is unavailable, use your hand to feel the shell of the converter. If the converter is hot to touch, the converter requires a cooling air stream

High duty cycles require additional cooling for the converter. System average power must be limited to the specified continuous maximum. Higher peak power, up to the maximum acceptable power limit, with an on time of up to 10 seconds may be obtained, if appropriate off time ensures that, on average, the continuous duty maximum power is not exceeded.

Table 5.26 Continuous Duty Max. Power & Full Power Duty Cycle

Configuration	Continuous Duty Max. Power	Full Power Duty Cycle
20 kHz / 1250 W	800 W	10 s on 10 s off (50% Duty Cycle)
20 kHz / 2500 W	1600 W	10 s on 10 s off (50% Duty Cycle)
20 kHz / 4000 W	2000 W	5 s on 15 s off (25% Duty Cycle)
30 kHz / 750 W	300 W	2 s on 2 s off (50% Duty Cycle)
30 kHz / 1500 W	800 W	2 s on 2 s off (50% Duty Cycle)
40 kHz / 400 W	300 W	10 s on 10 s off (50% Duty Cycle)
40 kHz / 800 W	400 W	10 s on 10 s off (50% Duty Cycle)

If converter cooling is required, use the following steps:

Table 5.27 Converter Cooling Procedure

Step	Action
1	Start with a 50 psi (345 kPa) air source or higher from a 0.06 in (1.5 mm) I.D. orifice.
2	Perform a run of welding operations.
3	Immediately after completing the welding run, check the converter temperature.
4	If the converter is still too hot, increase the diameter of the orifice in small increments until the temperature falls within the ranges in the chart.

A 0.06 in (1.5 mm) orifice at 50 psi (345 kPa) will result in a reading of 80 ft³ (2.26 m³) per hour. This should be sufficient to cool most operations requiring a cooling air stream. In continuous welding operations, or applications with longer duty cycles, it may be necessary to cool the horn as well as the converter. Horns may require cooling because of the heat transfer from contacting the work piece.

5.8 Testing the Installation

To test the power supply follow the procedure described in [7.6 Ultrasonics Test Procedure](#) in [Chapter 7: Operation](#).

5.9 Still Need Help?

Branson is pleased that you chose our product and we are here for you! If you need parts or technical assistance with your DCX Power Supply F-DP system, call your local Branson representative. Please refer to [1.4 How to Contact Branson](#) for a list of Branson key contacts.



Chapter 6: Converters and Boosters

6.1 Converters and Boosters 84

6.1 Converters and Boosters

A variety of converters and boosters available for use with the DCX Power Supply F-DP are illustrated in the following pages.



WARNING	High Voltage Hazard
	To avoid the possibility of electrical shock. Converters need to be properly grounded.
NOTICE	
	Special adaptor cables are available to connect to MS-style converters (CR20 and 4TR). See Table 9.8 DCX Power Supply F-DP System Cables .

Figure 6.1 20 kHz typical Converter Dimensions

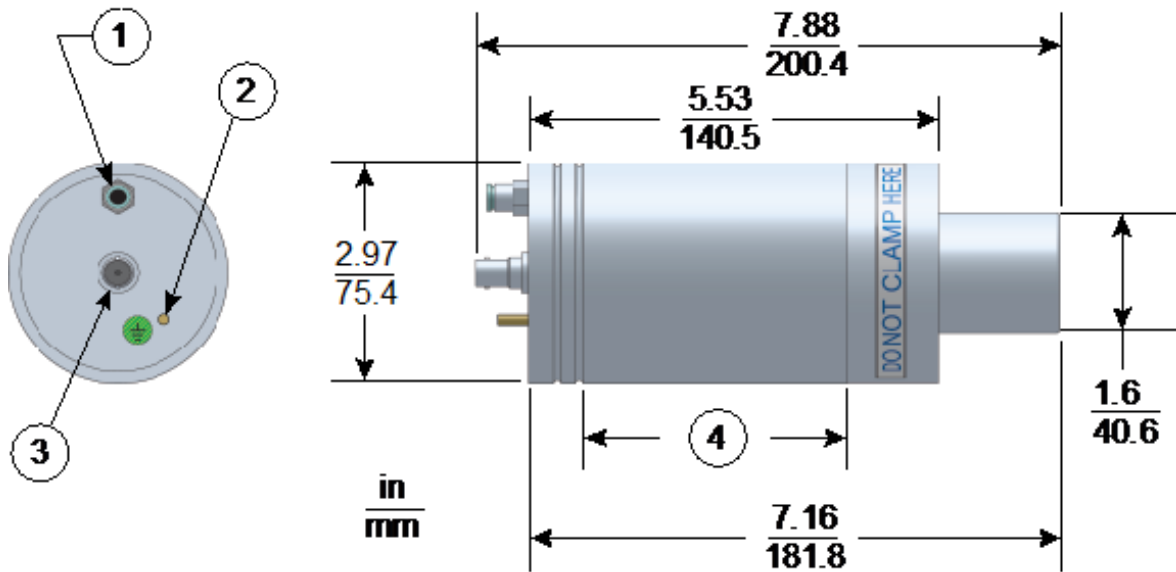

Table 6.1 20 kHz Converter

Item	Description
1	Air inlet
2	Ground stud
3	SHV connector
4	Grip area

Figure 6.2 20 kHz Booster Dimensions

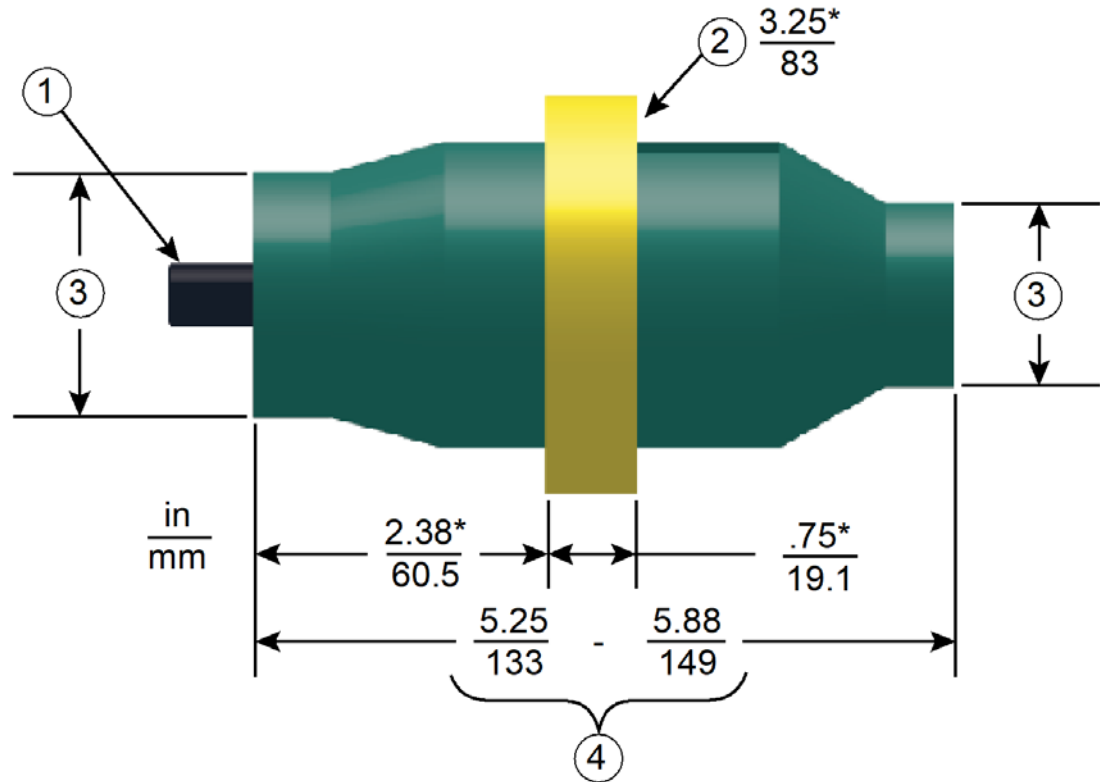

Table 6.2 20 kHz Booster

Item	Description
1	1/2 - 20 x 1 - 1/4 stud (Ti boosters) 1/2 - 20 x 1 - 1/2 stud (Al boosters)
2	Grip Ring Diameter
3	Variable
4	Varies with tuning and gain

* These dimensions do not vary.

Figure 6.3 20 kHz Converter/Booster/Horn, Typical Dimensions

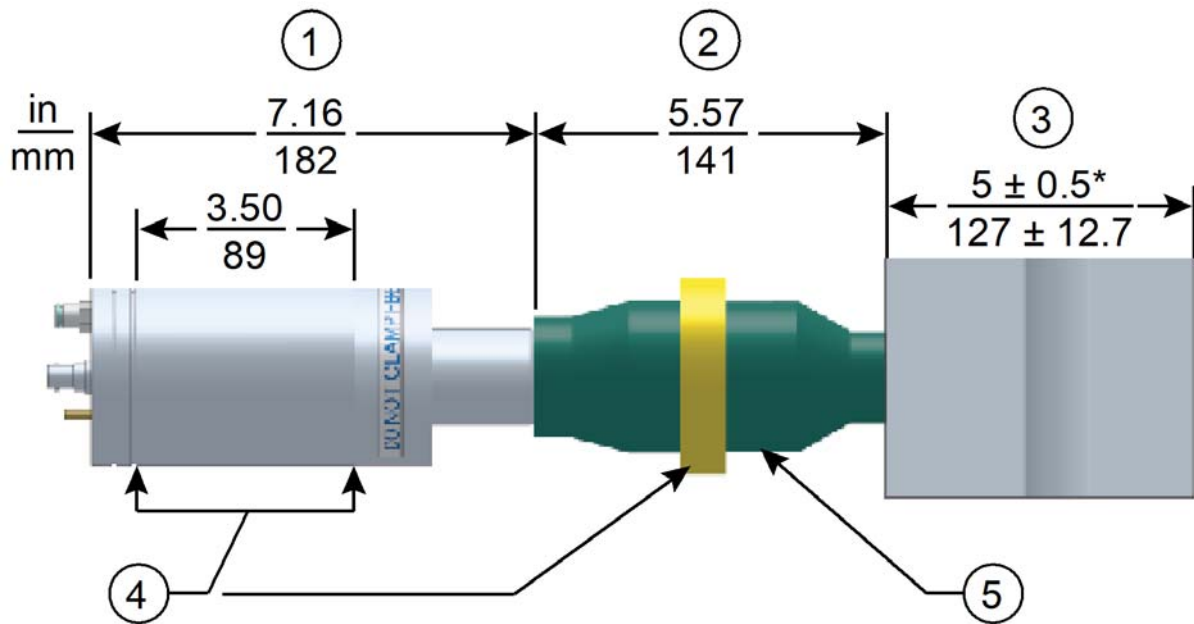

Table 6.3 20 kHz Converter/Booster/Horn

Item	Description
1	Converter
2	Booster
3	One-half wavelength horn
4	Recommended clamping area
5	Booster front end diameter will vary with amplitude

* Overall horn length can vary beyond these typical dimensions depending on the application.

Figure 6.4 30 kHz Converter Dimensions

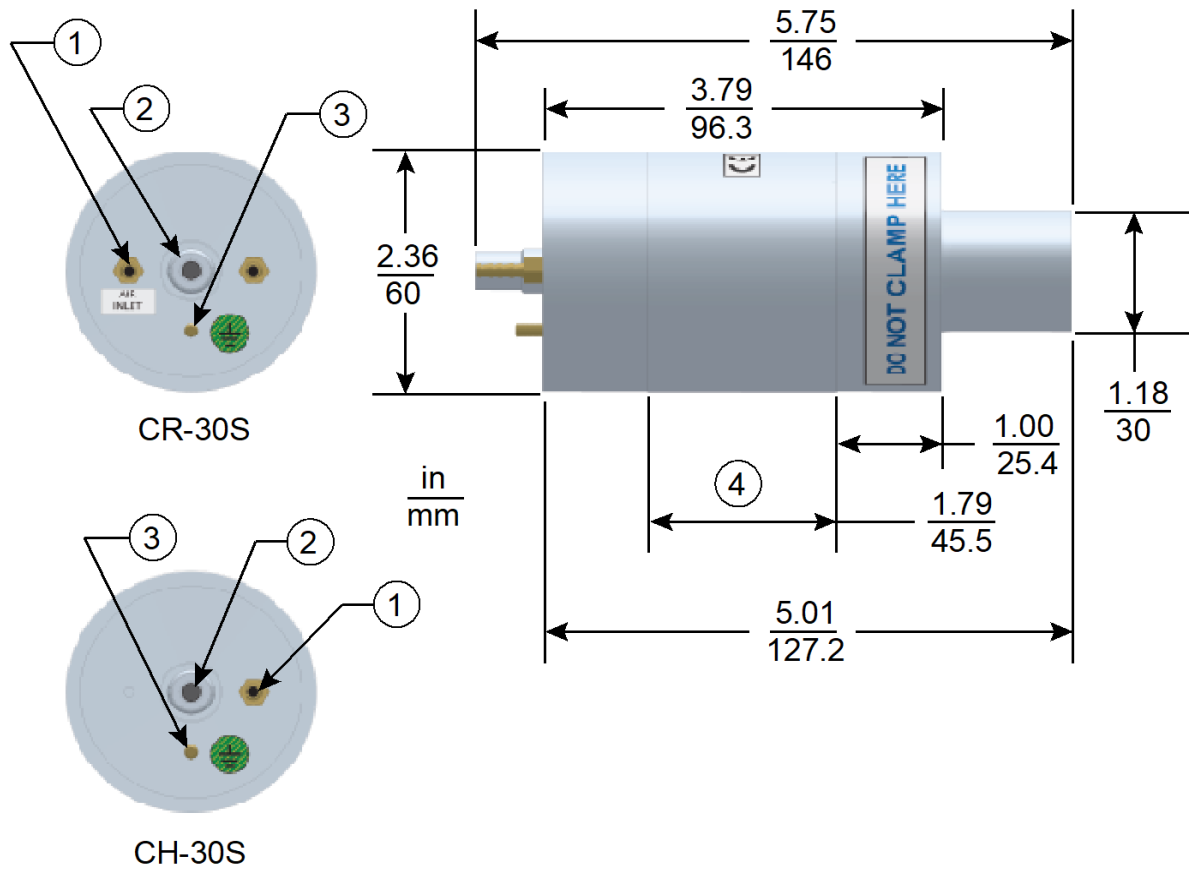

Table 6.4 30 kHz Converter

Item	Description
1	Air inlet
2	SHV connector
3	Ground stud
4	Grip area

CR-30S and CH-30S are dimensionally identical, and differ only in their respective cooling feature.

CR-30S has flow through cooling, and CH-30S has closed loop cooling (air circulates in the converter and returns to its source).

Figure 6.5 30 kHz Booster Dimensions

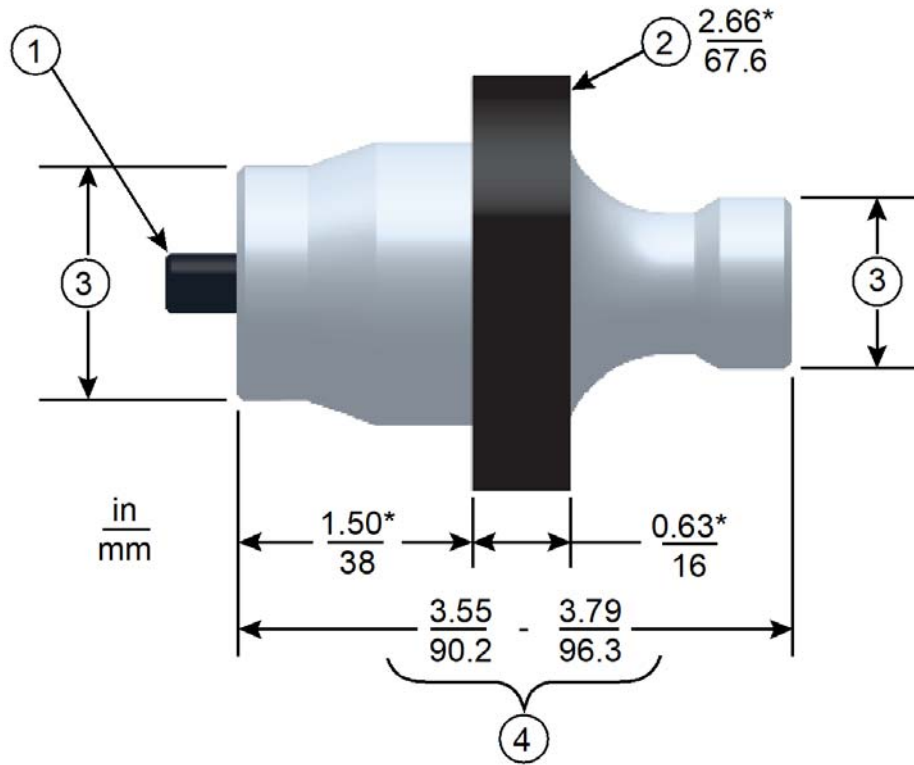

Table 6.5 30 kHz Booster

Item	Description
1	3/8 - 24 x 1 - 1/4 stud
2	Grip Ring Diameter
3	Variable
4	Varies with tuning and gain

* These dimensions do not vary.

Figure 6.6 30 kHz Converter/Booster/Horn, Typical Dimensions

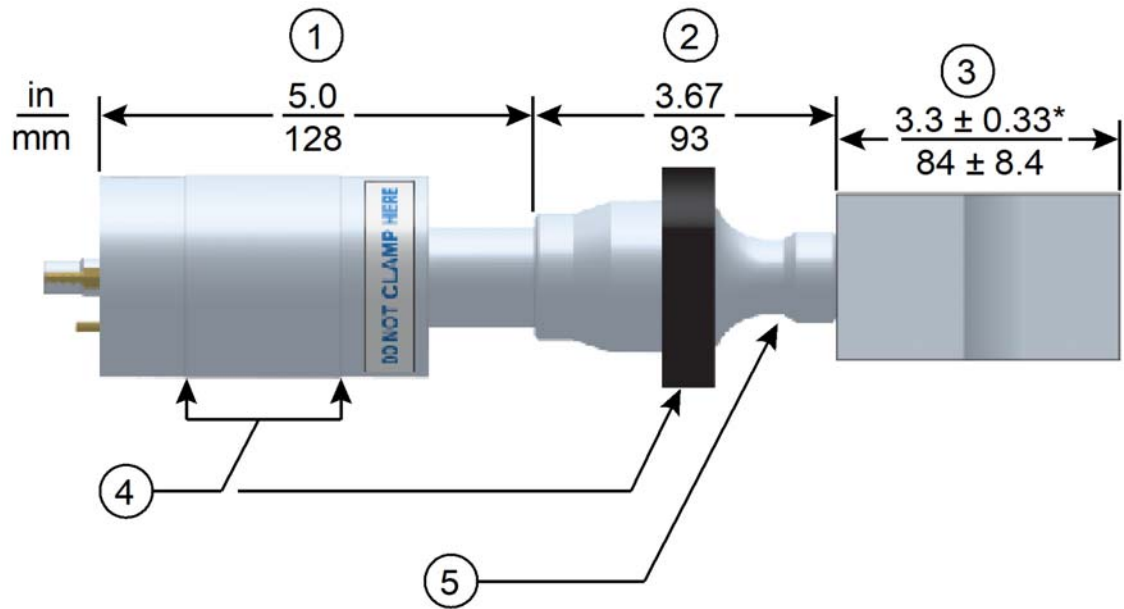

Table 6.6 30 kHz Converter/Booster/Horn

Item	Description
1	Converter
2	Booster
3	One-half wavelength horn
4	Recommended clamping area
5	Booster front end diameter will vary with amplitude

* Overall horn length can vary beyond these typical dimensions depending on the application.

Figure 6.7 40 kHz, 4TR Converter Dimensions

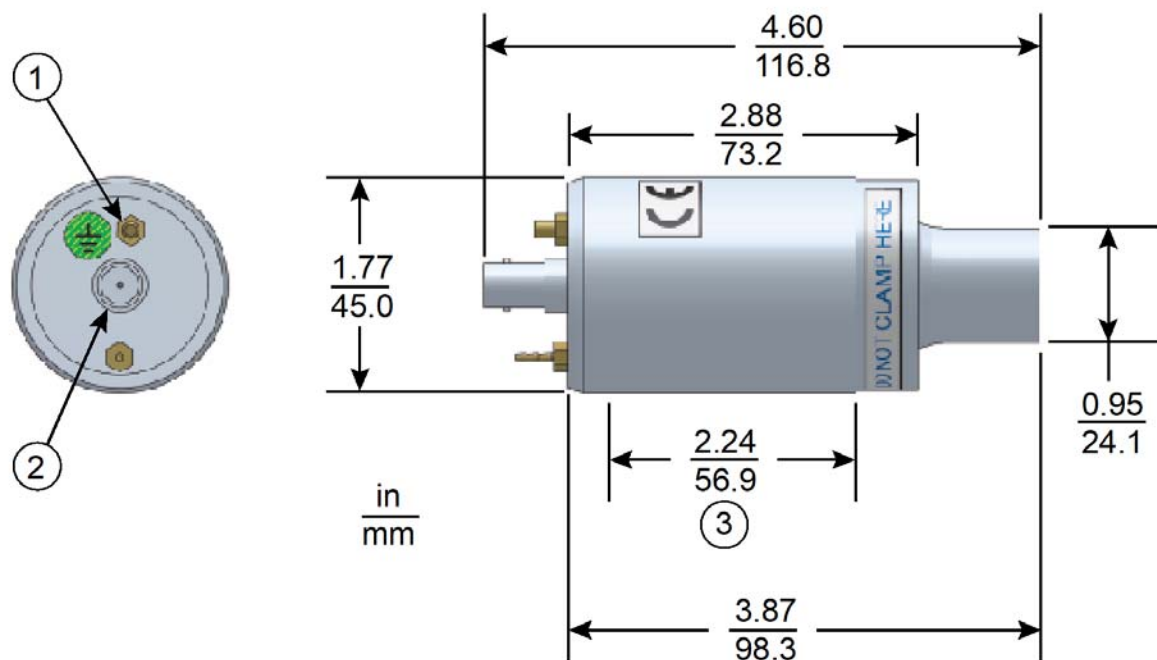

Table 6.7 40 kHz, 4TR Converter

Item	Description
1	Ground stud
2	SHV connector
3	Grip area

Figure 6.8 40 kHz Booster Dimensions

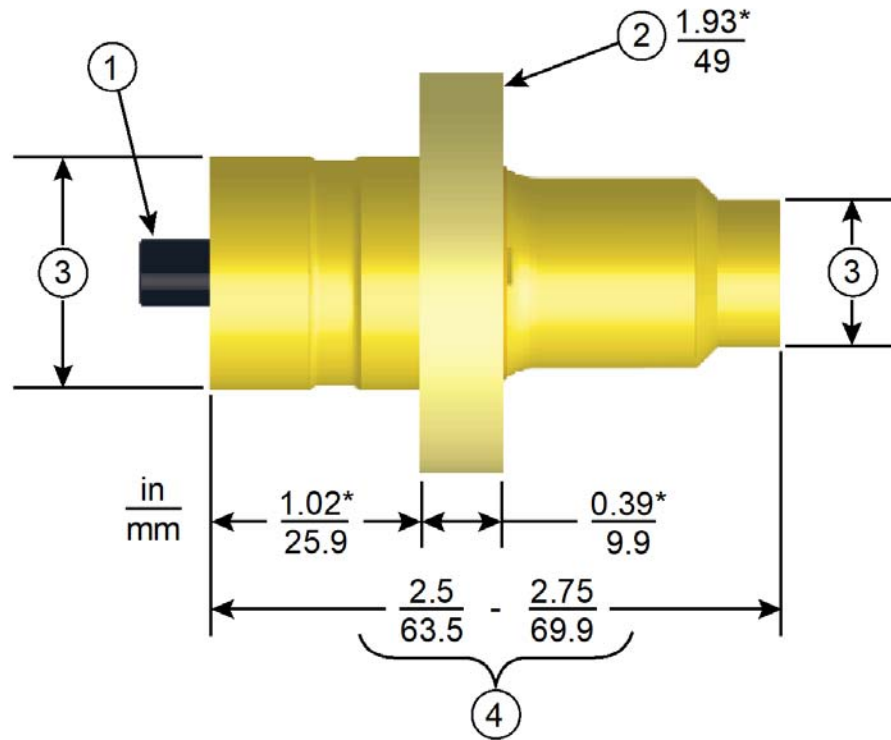

Table 6.8 40 kHz Booster

Item	Description
1	M8 x 1 - 1/4 stud (Ti boosters) M8 x 1 - 1/2 stud (Al boosters)
2	Grip ring diameter
3	Variable
4	Varies with tuning and gain

Figure 6.9 40 kHz Converter/Booster/Horn, Typical Dimensions

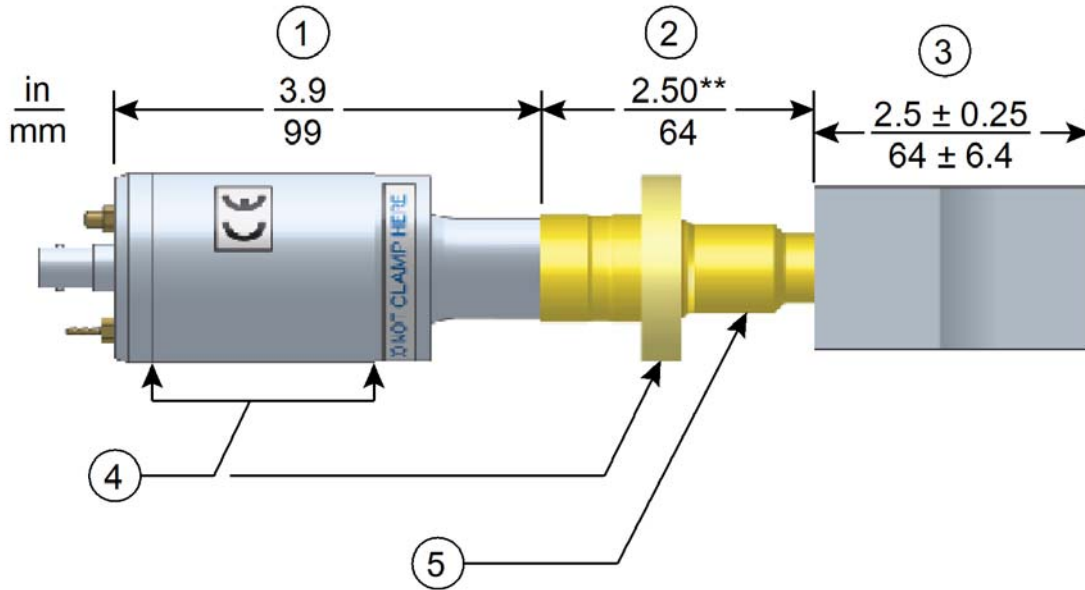

Table 6.9 40 kHz Converter/Booster/Horn

Item	Description
1	Converter
2	Booster
3	One-half wavelength horn
4	Recommended clamping area
5	Booster front end diameter will vary with amplitude

* Overall horn length can vary beyond these typical dimensions depending on the application.

** Dimension varies with tuning and gain.

6.1.1 Component Functional Description

Ultrasonic Stack

Converter

The converter is mounted in the customer's automation as part of the ultrasonic stack. The ultrasonic electrical energy from the power supply is applied to the converter (sometimes called the transducer). This transforms the high frequency electrical oscillations into mechanical vibrations at the same frequency as the electrical oscillations. The heart of the converter are piezoelectric ceramic elements. When subjected to an alternating voltage, these elements alternately expand and contract, resulting in better than 90% conversion of electrical to mechanical energy.

Booster

It is important to be able to modify the horn face amplitude for successful ultrasonic assembly. The booster provides a means to modify the amplitude. It is designed to couple different ratios of ultrasonic energy to the horn, which will in turn increase or decrease the amplitude at the face of the horn. This is accomplished by varying the ratios of the masses of the input and output half sections of the booster.

The booster is a resonant half-wave section of aluminum or titanium. It is mounted between the converter and the horn, as part of the ultrasonic stack. It also provides a clamping point for rigid stack mounting.

Horn

The horn is selected or designed for a specific application. Each horn is tuned typically as a half-wave section that applies the necessary force and vibration uniformly to the parts to be assembled. It transfers ultrasonic vibrations from the converter to the workpiece. The horn is mounted to the booster as part of the ultrasonic stack.

Depending on their profile, horns are referred to as stepped, conical, exponential, bar, or catenoidal. The shape of the horn determines the amplitude at the face of the horn. Depending on the application, horns can be made from titanium alloys, aluminum, or steel. Titanium alloys are the best materials for horn fabrication due to their high level of strength and low loss. Aluminum horns are usually chrome- or nickel-plated or hard-coated to reduce wear. Steel horns are for low amplitude requiring hardness, such as ultrasonic insertion applications.

Solid Mount Boosters

The solid mount booster is a one-half wave-length resonant section made exclusively of titanium. It is mounted between the converter and the horn, modifying the amplitude of vibration applied to the horn and providing a clamping point.

The solid mount booster is superior to prior versions in that deflection is minimized. This is the result of a redesigned clamp-ring which employs a metal-to-metal press fit rather than an O-ring assembly.

The advantage this booster offers is its improved rigidity. For continuous applications, this means more energy delivered to the product, while in plunge applications, improved alignment is possible. The solid mount provides improved positional alignment and will benefit continuous applications where high force, high side load, or high cycle rates are necessary. In plunge welding applications, overall deflection is reduced by an average of 0.0025 in. (0.064 mm) over a wide variety of materials, joint designs, and operating conditions. The results of this testing in combination with information drawn from field testing indicate that the solid mount will benefit plunge applications where precision alignment is necessary (such as staking, swaging, or insertion) or where concentricity/parallelism is critical.



Chapter 7: Operation

7.1	Setting Primary Parameters	96
7.2	Setting the Amplitude.	107
7.3	Resetting the Power Supply Alarms.	109
7.4	Configuring the Power Supply Registers	110
7.5	LCD Bar-Graph	114
7.6	Ultrasonics Test Procedure.	117
7.7	Using the I/O Connections.	119

7.1 Setting Primary Parameters

After analyzing your specific application, you can determine the Weld Mode to use to weld your parts. A Weld Mode is a set of parameters that governs the weld. Contact the Branson Ultrasonics Applications Laboratory for more information on determining the best mode for welding your application. See [1.4 How to Contact Branson](#).

There are five Weld Modes to choose from Continuous, Time, Energy, Peak Power, and Ground Detect Modes. The following table describes each mode:

Table 7.1 Summary of Weld Modes

Weld Mode	Description
Continuous	On this mode, ultrasonic energy will be delivered continuously while the start signal is present.
Time	You select the length of time (in seconds) that ultrasonic energy will be transmitted to your parts.
Energy	You select the amount of energy (in Joules) that will be transmitted to your parts. (A Joule is one Watt-Second.)
Peak Power	You select the peak power level (as a percentage of full power) at which the weld is terminated.
Ground Detect	<p>The DCX Power Supply F-DP provides ultrasonic energy until the horn comes in contact with your electrically isolated fixture or with the anvil, providing that you made an electrical connection between the actuator and your fixture or anvil.</p> <p>NOTICE Ground detect signal is required to terminate the weld and enter scrub time. It is necessary to install Ground Detect Kit EDP No. 125-063-061 in order to utilize this feature.</p>

NOTICE	
	In these modes, cutoffs can be used as secondary controls.

7.1.1 Continuous Mode

In this mode, ultrasonic energy will be delivered continuously while the start signal is present. Within Continuous Mode, you can also select several other parameters, ranging from afterburst to limits and cutoffs. For more information on setting the optional parameters within Continuous Mode, or any other welding mode, refer to the DCX A/F Series Web Page Instruction Manual.

Table 7.2 Continuous Mode Operational Sequence



Step	Action	Reference
1	<p>Press the Configuration key until the number icon (#) appears on the LCD.</p> <p>The power supply will display register 101 at every power up.</p>	
2	<p>Press and release the Up/Down arrow keys to select register 138. For a detailed description of available registers refer to Table 7.18 Power Supply Registers.</p>	
3	<p>Once you have reached register 138, press the Configuration key. The register value will be displayed; this is indicated by the circle icon.</p>	

Table 7.2 Continuous Mode Operational Sequence

Step	Action	Reference
4	Use the Up/Down arrow keys to select value 0 (Continuous mode), then press the Configuration key to confirm the selection.	
5	Continuous mode icon and amplitude value will be displayed.	



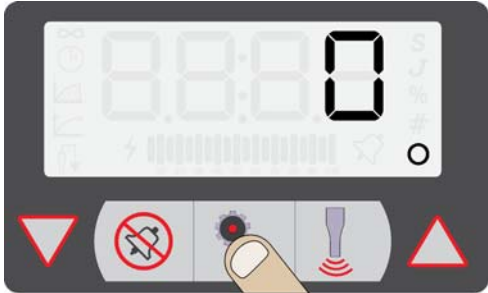
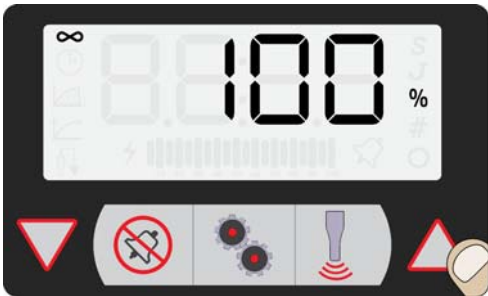

7.1.2 Selecting Time Mode

You can use Time Mode to select the length of time that ultrasonic energy is applied to your parts. Within Time Mode, you can also select several other parameters, ranging from afterburst to limits and cutoffs. For more information on setting the optional parameters within Time Mode, or any other welding mode, refer to the DCX A/F Series Web Page Instruction Manual.

Table 7.3 Time Mode Parameters

Parameter	Default	Max. Value	Min. Value
Time	0.010 seconds	30 seconds	0.010 seconds

Table 7.4 Selecting Time Mode

Step	Action	Reference
1	<p>Press the Configuration key until the number icon (#) appears on the LCD.</p> <p>The power supply will display register 101 at every power up.</p>	 <p>The LCD display shows '101' in the center. To the right of the display is a '#' icon. Below the display are several icons: a red triangle pointing down, a crossed-out lightning bolt, a gear, a hand pointing to a gear, a hand pointing to a lightning bolt, and a red triangle pointing up.</p>
2	<p>Press and release the Up/Down arrow keys to select register 138. For a detailed description of available registers refer to Table 7.18 Power Supply Registers.</p>	 <p>The LCD display shows '138' in the center. To the right of the display is a '#' icon. Below the display are several icons: a red triangle pointing down, a crossed-out lightning bolt, a gear, a hand pointing to a gear, a hand pointing to a lightning bolt, and a red triangle pointing up.</p>
3	<p>Once you have reached register 138, press the Configuration key. The register value will be displayed; this is indicated by the circle icon.</p>	 <p>The LCD display shows '138' in the center. To the right of the display is a circle icon. Below the display are several icons: a red triangle pointing down, a crossed-out lightning bolt, a gear, a hand pointing to a gear, a hand pointing to a lightning bolt, and a red triangle pointing up.</p>
4	<p>Use the Up/Down arrow keys to select value 1 (Time mode), then press the Configuration key to confirm the selection.</p>	 <p>The LCD display shows '138' in the center. To the right of the display is a circle icon. The rightmost digit of '138' is replaced by a '1'. Below the display are several icons: a red triangle pointing down, a crossed-out lightning bolt, a gear, a hand pointing to a gear, a hand pointing to a lightning bolt, and a red triangle pointing up.</p>

7.1.2.1 Setting Time Mode Parameters

Table 7.5 Setting Time Mode Parameters

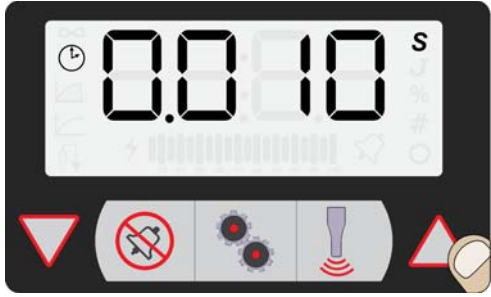
Step	Action	Reference
1	Set the Power Supply to Time Mode.	See 7.1.2 Selecting Time Mode .
2	Time mode icon and parameter value will be displayed. Use the Up/Down keys to enter the desired parameter value.	

7.1.3 Selecting Energy Mode

You can use Energy Mode to select the amount of ultrasonic energy that is applied to your parts. Within Energy Mode, you can also select several other parameters, ranging from afterburst to limits and cutoffs. For more information on setting the optional parameters within Energy Mode, or any other welding mode, refer to the DCX A/F Series Web Page Instruction Manual.

Table 7.6 Energy Mode Parameters

Parameter	Default	Max. Value	Min. Value
Energy	500 Joules	9999 Joules	0.1 Joules

Table 7.7 Selecting Energy Mode





Step	Action	Reference
1	Press the Configuration key until the number icon (#) appears on the LCD. The power supply will display register 101 at every power up.	

Table 7.7 Selecting Energy Mode

Step	Action	Reference
2	Press and release the Up/Down arrow keys to select register 138. For a detailed description of available registers refer to Table 7.18 Power Supply Registers .	
3	Once you have reached register 138, press the Configuration key. The register value will be displayed; this is indicated by the circle icon.	
4	Use the Up/Down arrow keys to select value 2 (Energy mode), then press the Configuration key to confirm the selection.	

7.1.3.1 Setting Energy Mode Parameters

Table 7.8 Setting Energy Mode Parameters

Step	Action	Reference
1	Set the Power Supply to Energy Mode.	See 7.1.3 Selecting Energy Mode .

Table 7.8 Setting Energy Mode Parameters

Step	Action	Reference
2	Energy mode icon and parameter value will be displayed. Use the Up/Down keys to enter the desired parameter value.	 <p>The image shows a digital display with the value '5000.0 J' in large black digits. To the left of the digits is a small icon of a signal tower. To the right is a small 'J' icon. Below the display is a control panel with several icons: a red triangle pointing down, a red circle with a diagonal line through it, two gears, a red exclamation mark, and a red triangle pointing up. A hand is shown pressing the up triangle button.</p>

7.1.4 Selecting Peak Power Mode

You can use Peak Power Mode to select the maximum percentage of the total available power that will be used to process your welds. When the power level you set is reached, ultrasonics will be terminated. From within Peak Power Mode, you can also select several other parameters, ranging from afterburst to limits and cutoffs. For more information on setting the optional parameters within Peak Power Mode, or any other welding mode, refer to the DCX A/F Series Web Page Instruction Manual.

Table 7.9 Peak Power Mode Parameters

Parameter	Default	Max. Value	Min. Value
Peak Power	1%	100%	1%

Table 7.10 Selecting Peak Power Mode





Step	Action	Reference
1	Press the Configuration key until the number icon (#) appears on the LCD. The power supply will display register 101 at every power up.	
2	Press and release the Up/Down arrow keys to select register 138. For a detailed description of available registers refer to Table 7.18 Power Supply Registers .	
3	Once you have reached register 138, press the Configuration key. The register value will be displayed; this is indicated by the circle icon.	

Table 7.10 Selecting Peak Power Mode

Step	Action	Reference
4	Use the Up/Down arrow keys to select value 3 (Peak Power mode), then press the Configuration key to confirm the selection.	

7.1.4.1 Setting Peak Power Mode Parameters

Table 7.11 Setting Peak Power Mode Parameters

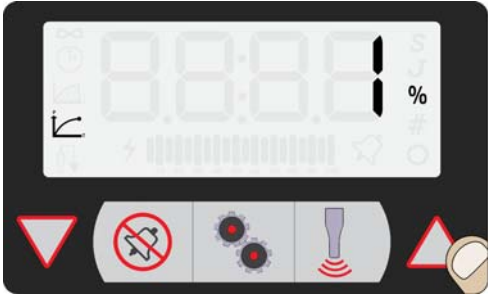
Step	Action	Reference
1	Set the Power Supply to Peak Power Mode.	See 7.1.4 Selecting Peak Power Mode .
2	Peak Power mode icon and parameter value will be displayed. Use the Up/Down keys to enter the desired parameter value.	

7.1.5 Selecting Ground Detect Mode

You can use Ground Detect Weld Mode to have ultrasonic energy turn off when the horn comes in contact with your electrically isolated fixture or anvil.

From within Ground Detect Mode, you can also select several other parameters, ranging from Hold Time (in seconds) to Suspect and Reject Limits. For more information on setting the optional parameters within Ground Detect Mode, or any other welding mode, refer to the DCX A/F Series Web Page Instruction Manual.

Table 7.12 Ground Detect Mode Parameters

Parameter	Default	Max. Value	Min. Value
Ground Detect	0.001 seconds	0.500 seconds	0.001 seconds

Table 7.13 Selecting Ground Detect Mode





Step	Action	Reference
1	<p>Press the Configuration key until the number icon (#) appears on the LCD.</p> <p>The power supply will display register 101 at every power up.</p>	
2	<p>Press and release the Up/Down arrow keys to select register 138. For a detailed description of available registers refer to Table 7.18 Power Supply Registers.</p>	
3	<p>Once you have reached register 138, press the Configuration key. The register value will be displayed; this is indicated by the circle icon.</p>	

Table 7.13 Selecting Ground Detect Mode

Step	Action	Reference
4	Use the Up/Down arrow keys to select value 4 (Ground Detect mode), then press the Configuration key to confirm the selection.	

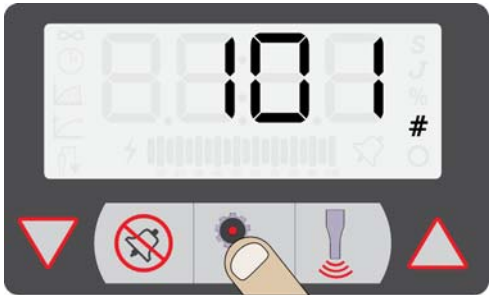
7.1.5.1 Setting Ground Detect Mode Parameters

Table 7.14 Setting Ground Detect Mode Parameters

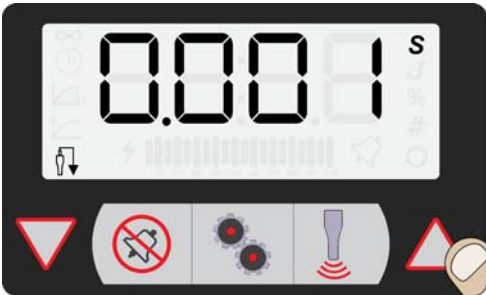
Step	Action	Reference
1	Set the Power Supply to Ground Detect Mode.	See 7.1.5 Selecting Ground Detect Mode .
2	Ground Detect mode icon and parameter value will be displayed. Use the Up/Down keys to enter the desired parameter value.	

7.2 Setting the Amplitude

7.2.1 Using the Front Panel Controls

At power up the DCX Power Supply F-DP will display the last amplitude setting on the LCD. It can also be set to show weld mode.

Figure 7.1 LCD at Power Up



Table 7.15 Setting the Amplitude Using the Front Panel Controls

Step	Action	Reference
1	Press the Configuration key until the percentage icon (%) and no mode icons are displaying on the LCD.	
2	<p>Press and release the Up or Down arrow keys to select the desired amplitude at 1% increments.</p> <p>Press and hold down the Up or Down arrow keys and the Amplitude will auto increment at 1% increments every quarter of a second.</p> <p>After holding down an arrow key for four straight seconds, the amplitude will auto increment at 5% increments every quarter of a second.</p>	

7.2.2 Using External Amplitude Control

When External Amplitude Control is enabled, the front panel amplitude control is disabled and the LCD displays four dashes (see [Figure 7.2 LCD when in External Amplitude Control Mode](#) below).

Figure 7.2 LCD when in External Amplitude Control Mode

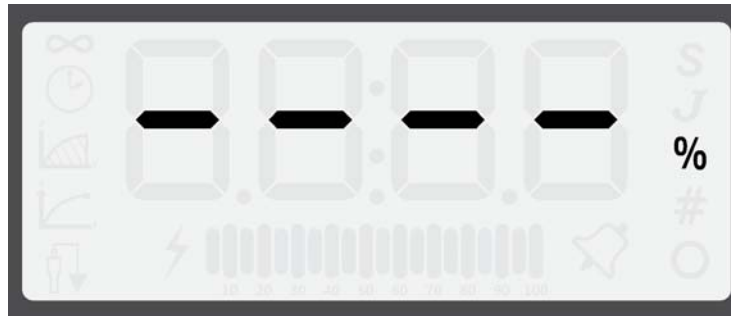

The ultrasonic amplitude can be controlled using one of the two analog input pins on the user I/O connector (pins 17 and 18) or through the Profibus interface.

7.2.3 Using the Web Page Interface

The ultrasonic amplitude can be set to a user specified value using the web page interface. For more information, refer to the DCX A/F Series Web Page Instruction Manual.

7.3 Resetting the Power Supply Alarms

You need to reset the weld system when you get an overload. When there is an overload, the alarm icon appears on the front panel LCD and the General Alarm output on the user I/O connector becomes active. The procedure for resetting the power supply depends on the power supply alarm settings. Refer to [Table 7.16 Resetting the DCX Power Supply F-DP](#) for reset procedures.

Table 7.16 Resetting the DCX Power Supply F-DP

Alarm Setting	Reset Procedure
Reset Required	Press the front panel Reset key. You can also send an External Reset signal.
No Reset Required	Remove and re-apply the start signal.

For more information on interfacing the DCX Power Supply F-DP using the user I/O connections refer to [5.4.1 User I/O Connections](#) in [Chapter 5: Installation and Setup](#).

7.4 Configuring the Power Supply Registers

At power up the DCX Power Supply F-DP will display the last amplitude setting, this is indicated by the percentage icon (%) on the LCD. Refer to [Figure 7.1 LCD at Power Up](#).

Table 7.17 Steps to Configure the Power Supply Registers





Step	Action	Reference
1	<p>Press the Configuration key until the number icon (#) appears on the LCD.</p> <p>The power supply will display register 101 at every power up.</p>	 <p>The image shows the LCD display with the number '101' in the center. To the right of the number is a '#' icon. Below the LCD is a control panel with several buttons: a left arrow, a 'no lightning bolt' icon, a red dot, a warning bell icon, and a right arrow. A finger is shown pressing the red dot button.</p>
2	<p>Press and release the Up or Down arrow keys to select the desired register. For a detailed description of available registers refer to Table 7.18 Power Supply Registers.</p>	 <p>The image shows the LCD display with the number '108' in the center. To the right of the number is a '#' icon. Below the LCD is the same control panel as in step 1. A finger is shown pressing the right arrow button.</p>
3	<p>Once you have reached the desired register, press the Configuration key. The register value will be displayed, this is indicated by the circle icon.</p>	 <p>The image shows the LCD display with the number '80' in the center. To the right of the number is a circle icon. Below the LCD is the same control panel as in step 1. A finger is shown pressing the red dot button.</p>

Table 7.17 Steps to Configure the Power Supply Registers

Step	Action	Reference
4	<p>Press and release the Up or Down arrow keys to enter the desired value at 1 increments.</p> <p>Press and hold down the Up and Down arrow keys and the value will auto increment at 1 increments every quarter of a second.</p> <p>After holding down an arrow key for four straight seconds, the value will auto increment at 5 increments every quarter of a second.</p> <p>Or press the Reset key to enter the default value. For detailed default values of available registers refer to Table 7.18 Power Supply Registers.</p>	
5	<p>Press the Configuration key to save the value. The current amplitude setting will be displayed only for continuous mode. For all the other modes, it will display the primary parameter of that mode.</p>	

7.4.1 Power Supply Registers

Table 7.18 Power Supply Registers

Register	Description	Min. Value	Max. Value	Default Value
101	Software version	N/A	N/A	N/A
102	Bar graph identification after weld complete 0=Power 1=Frequency	0	1	0
104	External amplitude control - user analog input or fieldbus 0=Off 1=On	0	1	0
105	Start ramp time (ms)	10	1000	80

Table 7.18 Power Supply Registers

Register	Description	Min. Value	Max. Value	Default Value
106	Store frequency at end of weld 0=Off 1=On	0	1	1
107	Power up seek/scan 0=Off 1=Seek, 2=Scan	0	2	1
108	Seek ramp time (ms)	10	1000	80
109	Timed seek (every 60 seconds) 0=Off 1=On	0	1	0
110	Seek time (ms)	10	1000	500
111	External Frequency Offset 0=Off 1=On	0	1	0
112	Frequency Offset Value			0
113	Cutoffs 0=Off 1=On	0	1	0
114	Limits 0=Off 1=On	0	1	0
115	Restore Defaults 0=Off 1=Just weld preset 2=System defaults	0	2	0
116	IP Address - 1	0	255	192
117	IP Address - 2	0	255	168
118	IP Address - 3	0	255	10
119	IP Address - 4	0	255	100
120	Gateway for IP Address - 1	0	255	192
121	Gateway for IP Address - 2	0	255	168
122	Gateway for IP Address - 3	0	255	10
123	Gateway for IP Address - 4	0	255	1

Table 7.18 Power Supply Registers

Register	Description	Min. Value	Max. Value	Default Value
124	Subnet Mask for IP Address - 1	0	255	255
125	Subnet Mask for IP Address - 2	0	255	255
126	Subnet Mask for IP Address - 3	0	255	255
127	Subnet Mask for IP Address - 4	0	255	0
128	DHCP Settings 0=Server 1=Client 2=Static 3=Restore Registers 116-128 to default	0	3	2
129	Fieldbus Address 1	0	Fieldbus Dependant	Fieldbus Dependant
130	Fieldbus Address 2	0	255	
131	Fieldbus Address 3	0	255	
132	Fieldbus Address 4	0	255	
134	Backlight Timeout (s) 0=Always on	0	9999	600
135	Auto scroll step size	1	50	5
136	Power on display 0=Weld Mode 1=Amplitude	0	1	1
138	Weld Mode 0=Continuous 1=Time 2=Energy 3=Peak Power 4=Ground Detect	0	4	0
139	MAC Address 1	0	FFFF	N/A
140	MAC Address 2	0	FFFF	N/A
141	MAC Address 3	0	FFFF	N/A
154	Restore registers 142–153 to default.	0	1	0

7.5 LCD Bar-Graph

While ultrasonic power is active the LCD will always display the power value on the 20-segment LCD bar-graph as a percentage of the maximum output power.

At the end of a weld or test cycle, the bar-graph is factory set to represent the cycle's peak power as a percentage of the maximum output power.

The power supply can also be configured to show a single bar on the LCD bar-graph to represent the stack operating frequency stored at the end of each weld or test cycle. This option can be used to troubleshoot operating frequency changes as a result of heating effects, coupling, tooling wear, etc.

For information on how to set the power supply registers see [7.4 Configuring the Power Supply Registers](#).

7.5.1 Power Bar-Graph Interpretation

The lightning bolt left of the bar-graph indicates ultrasonic power is running. Each of the segments represent 5% increments of the maximum output power. The segments will only appear if the output power has exceeded the value represented. For example if the power is 4% only the lightning bolt will be on. When it reaches 5% the first bar-graph segment will appear.

Table 7.19 Power Bar-Graph Interpretation Examples

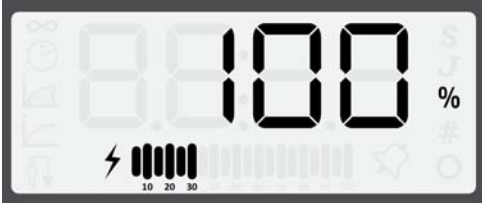
Description	Reference
<p>In this example only the lightning bolt appears left of the bar-graph. This means power is between 0% and 5%. If the power supply is 800 W the actual output power is between 0 W and 40 W.</p>	
<p>In this example the first six segments appear on the bar-graph. This means power is between 30% and 35%. If the power supply is 800 W, the actual output power is between 240 W and 280 W.</p>	

7.5.2 Frequency Bar-Graph Interpretation

The actual frequency depends on the power supply's operating frequency. Use [Table 7.20](#) to [Table 7.22](#) below to interpret frequency bar-graph readings.

NOTICE	
	<p>If there is a test overload or an external memory reset signal is received, then the 50% segment will be displayed and blinking.</p>

Table 7.20 Frequency Bar-Graph Interpretation - 20 kHz (50 Hz Segment)

20 kHz (50 Hz/Segment)	
1	19,475–19,524
2	19,525–19,574
3	19,575–19,624
4	19,625–19,674
5 (25%)	19,675–19,724
6	19,725–19,774
7	19,775–19,824
8	19,825–19,874
9	19,875–19,924
10 (50%)	19,925–19,974
11	19,975–20,024
12	20,025–20,074
13	20,075–20,124
14	20,125–20,174
15 (75%)	20,175–20,224
16	20,225–20,274
17	20,275–20,324
18	20,325–20,374
19	20,375–20,424
20 (100%)	20,425–20,474

Table 7.21 Frequency Bar-Graph Interpretation - 30 kHz (76 Hz Segment)

30 kHz (76 Hz/Segment)	
1	29,278–29,353
2	29,357–29,429
3	29,430–29,501
4	29,502–29,581
5 (25%)	29,582–29,657
6	29,658–29,733
7	29,734–29,809
8	29,810–29,885
9	29,886–29,961
10 (50%)	29,962–30,037
11	30,038–30,113
12	30,114–30,189
13	30,190–30,265
14	30,266–30,341
15 (75%)	30,342–30,417
16	30,418–30,493
17	30,494–30,569
18	30,570–30,645
19	30,646–30,721
20 (100%)	30,722–30,797

Table 7.22 Frequency Bar-Graph Interpretation - 40 kHz (100 Hz/Segment)

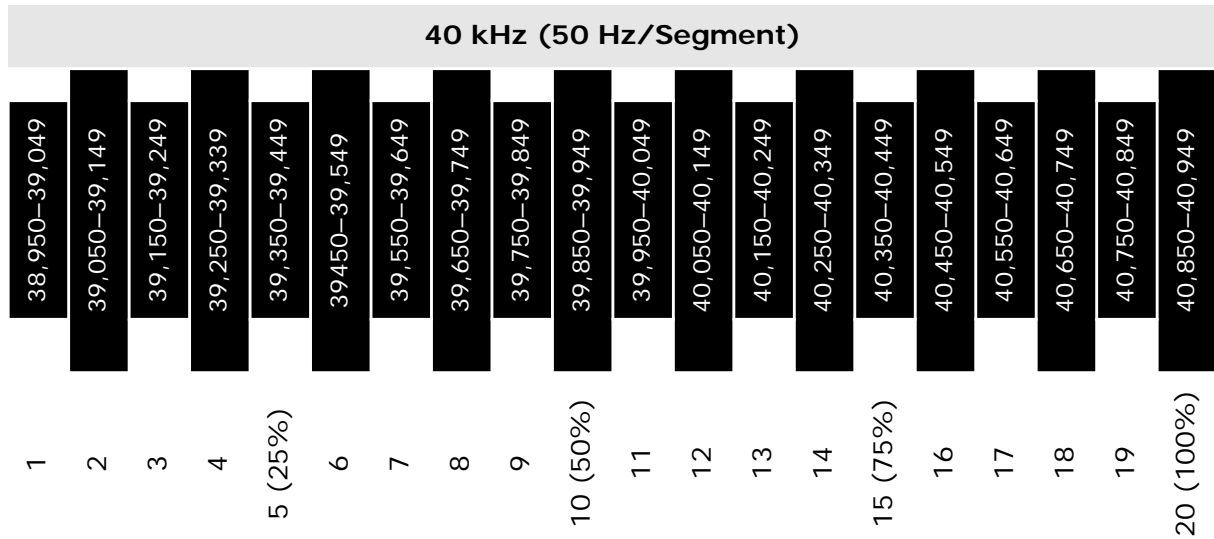



Table 7.23 Frequency Bar-Graph Interpretation Examples

Description	Reference
In this example the bar is located in the 11th segment. If the power supply is a 20 kHz unit, the stack is running in the frequency range of 19,975 Hz to 20,024 Hz.	
In this example the bar is located in the 7th segment. If the power supply is a 20 kHz unit, the stack is running in the frequency range of 19,775 Hz to 19,824 Hz.	

7.6 Ultrasonics Test Procedure

The Ultrasonics Test function measures ultrasonic power dissipated by the ultrasonic stack with no load. The ultrasonics test procedure involves an automatic matching of the frequency of the power supply to the frequency of the converter-booster-horn stack.

WARNING	High Voltage Hazard
	<p>Ensure that no one is in contact with the horn when testing the power supply.</p> <p>Do not cycle the welding system if either the RF cable or converter is disconnected.</p>

WARNING	High Voltage Hazard
	<p>Ensure the power supply is properly connected, as indicated in 5.3 Installation Steps.</p>

7.6.1 Using the Front Panel Controls

NOTICE	
	<p>To use the front panel controls, the DCX Power Supply F-DP unit must be in manual mode.</p>

Table 7.24 Power Supply Ultrasonic Test Procedure (Front Panel)



Step	Action	Reference
1	Turn on the power supply and 24 V. The front panel Power LED and LCD turn on.	

Table 7.24 Power Supply Ultrasonic Test Procedure (Front Panel)

Step	Action	Reference
2	<p>Press the test key for 1-2 seconds, then release. The Sonics Active indicator appears while the test key is pressed. If the power supply alarm indicator does not appear, the test procedure is finished.</p>	 <p>The image shows a digital display on a control panel. The display shows '100' followed by a '%' symbol. Below the display, there is a lightning bolt icon and a bar graph. A hand is shown pressing a button on the right side of the panel.</p>
3	<p>If the alarm indicator appears, press the alarm reset key and repeat step 2 one time only. If the alarm persists, refer to 9.5 Troubleshooting. See Appendix A: Alarms for additional information.</p>	 <p>The image shows the same digital display as in step 2, but now with a starburst alarm icon in the bottom right corner of the display area. A hand is shown pressing a button on the left side of the panel.</p>

7.7 Using the I/O Connections

Table 7.25 Power Supply Ultrasonic Test Procedure (User I/O)

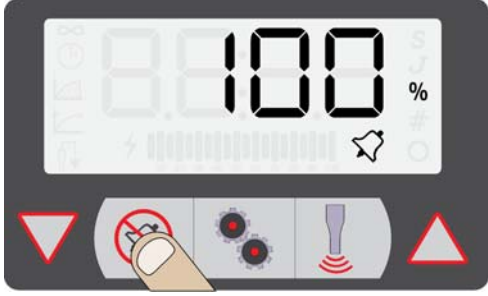

Step	Action	Reference
1	Wire the necessary I/O signals as shown on Figure 7.3 Test Connections , or using a similar setup.	Refer to Figure 7.3 Test Connections below.
2	Turn on the power supply and 24 V. The front panel Power LED should turn on. Ready Signal should become active.	
3	Send an External Test signal for 1-2 seconds. The Sonics Active output will become active and the Sonics Active indicator appears while the External Start Signal is present. If the General Alarm output/ alarm indicator does not become active, the test procedure is finished. NOTICE Power supply must be in manual mode.	
4	If the General Alarm output/alarm indicator becomes active, send an External Reset signal and repeat step 2 one time only. If the alarm persists, refer to 9.5 Troubleshooting .	

Figure 7.3 Test Connections



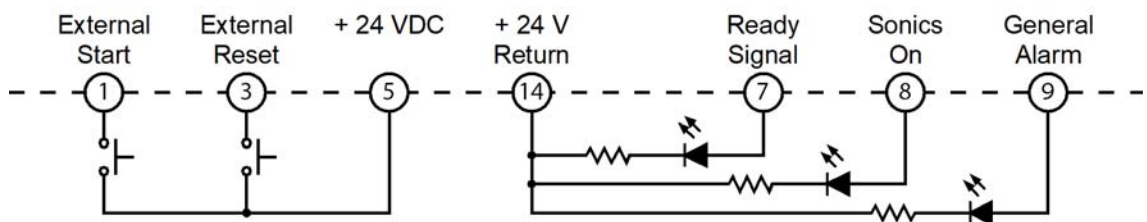

Chapter 8: PROFIBUS DP Operation

8.1	PROFIBUS DP	122
8.2	Configuration	125
8.3	Implicit Messaging	134

8.1 PROFIBUS DP

PROFIBUS is an open, vendor independent Field Bus standard for a wide range of applications in industrial automation.

8.1.1 LED Status Indicator

To get a fast overview about the status of the DCX Power Supply F-DP, two LEDs are placed on the front of the unit. The subsequent table describes the meaning of the LEDs.

Figure 8.1 LED Status Indicator

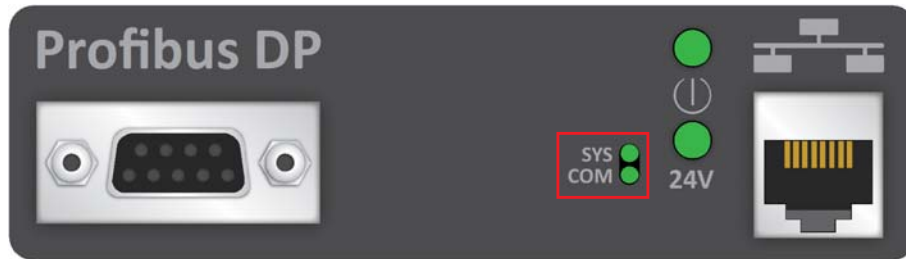

Table 8.1 DCX Power Supply F-DP LED Status Indicator

LED	Color	State	Description
SYS	Green	On	Operating System running.
	Green/ Yellow	Blinking green/ yellow	Bootloader is waiting for firmware.
	Yellow	Static	Bootloader is waiting for software.
	-	Off	Power supply for the device is missing or hardware defect.
COM	Green	Flashing (acyclic)	No configuration or stack error.
	Green	Flashing (cyclic)	PROFIBUS is configured, but bus communication is not yet released from the application.
	Green	On	Communication to all Slaves is established.
	Red	Flashing (cyclic)	Communication to at least one Slave is disconnected.
	Red	On	Communication to one/all Slaves is disconnected.

8.1.2 Bus Communication

The PROFIBUS specification defines the technical characteristics of a serial field bus system that links distributed digital controllers on the network, from field level to cell level. PROFIBUS is a multi-master system that allows the joint operation of several automation, engineering or visualization systems with their distributed peripherals on one bus. PROFIBUS distinguishes between the following types of devices:

- Master devices determine the data communication on the bus. A master can send messages without an external request when it holds the bus access rights (the token). Masters are also called active stations

- Slave devices include motion controllers, drives, I/O devices, valves, and transducers. Slaves do not have bus access rights and can only acknowledge received messages or send messages to the master when requested to do so. Slave devices are passive stations and require only small portions of the bus protocol
- The majority of PROFIBUS-DP applications are located at field level. The field level typically includes slave devices such as the S2K motion controller station and host devices like PLC or PC control systems for the PROFIBUS-DP master station. Operator interfaces and DCS type systems usually operate at the cell level

Table 8.2 Data Bandwidth Demands on PROFIBUS Communications Systems

Level	Amount of Data	Transmission Duration	Transmission Frequency
Management level	Megabytes	Hours/Minutes	Day/Shift
Cell level	Kilobytes	Seconds	Hours/Minutes
Field Level	Bytes	Several 100 microseconds to 100 milliseconds	10 to 100 milliseconds
Actuator sensor level	Bits	Microseconds to	Milliseconds

8.1.3 Network Topology

A PROFIBUS-DP network may have up to 127 stations (address 0-126), however address 126 is reserved for commissioning purposes. The bus system must be sub-divided into individual segments to handle this many participants. These segments are linked by repeaters. The function of a repeater is to condition the serial signal to allow connection of segments. In practice, both regenerating and non-regenerating repeaters may be used. Regenerating repeaters actually condition the signal to allow increased range of the bus. Up to 32 stations are allowed per segment and the repeater counts as a station address.

The user assigns a unique PROFIBUS station address to identify each master, slave, or repeater in the entire network. Each participant on the bus must have a unique station address.

8.1.4 Network Connectors

PROFIBUS connections are created with a 9 pin sub-D connector. A minimum connection consists of a shielded twisted-pair cable (shield to pin 1 and twisted-pair wires to pins 3 and 8) with terminating connections in the appropriate bus plugs. The pin to signal conventions are described below:

Table 8.3 Pin-out Listing for the PROFIBUS Bus Plug Connector

Pin	Signal	Designation
1	Shield	Shield Protective Ground
2	M24	Ground Common of the 24V output voltage
3	RxDfTxD-P	Receive data / transmission data plus
4	CNTR-P	Control signal for repeaters (direction control)
5	DGND	Data transmission potential (ground to 5V)
6	VP	Supply voltage of the terminating resistance(+ 5V)

Table 8.3 Pin-out Listing for the PROFIBUS Bus Plug Connector

Pin	Signal	Designation
7	P24	Output voltage (+ 24V)
8	RxDfTxD-N	Receive data transmission data negative
9	CNTR-N	Control signal for repeaters (direction control)

8.1.5 Network Segment Length

A PROFIBUS network uses either fiber optic or RS-485 copper media. The copper bus line, Line Type A is the recommended cable type. A more economical copper cable, Line Type B, is commonly used for smaller installations. It is extremely important to use cable rated to PROFIBUS specifications. The higher the baud rate selected and the longer the distances involved, the more critical cable selection becomes. (PROFIBUS cable has a distinctive purple color.)

The data rates for network communication with maximum segment trunk length per cable type are provided below. Multiple segments may be connected via repeater stations to extend the total bus length.

Table 8.4 Line Types

Baud Rate	Line A Distance (Max)	Line B Distance (Max)	Glass Fiber
9.6KBps, 19.2KBps and 93.75KBps	1200m	1200m	6Km
187.5KBps	1000m	600m	6Km
500KBps	400m	200m	6Km
1.5MBps	200m	N/A	6Km
3, 6 and 12MBps	100m	N/A	6Km

NOTICE	
	<p>The two physical ends of the PROFIBUS network should be terminated. There should be two, and only two, terminators on a network.</p>

8.2 Configuration

Due to the many different makes of PLCs available, the information in this section may not be relevant to all types of PLCs. These configuration procedures are intended for users with at least a basic knowledge of the CIMPLICITY Machine Edition Logic Developer software and the Series 90-30 PLC. For help with using the software, please see the software's built-in help system.

8.2.1 Communication

After the PROFIBUS Master has recognized the DCX Power Supply F-DP, the parameters of the DCX Power Supply F-DP can be set by means of "User Parameters". This parameter assignment should not be confused with parameters that are transmitted via the communication channel in the I/O image. The "User Parameters" are transmitted prior to the subsequent DATA_EXCHANGE services. The following "User Parameters" have been implemented:

Table 8.5 User Parameters

Byte	Description
1	PROFIBUS Standard
2	PROFIBUS Standard
3	PROFIBUS Standard
4	PROFIBUS Standard
5	PROFIBUS Standard
6	PROFIBUS Standard
7	PROFIBUS Standard
8	PROFIBUS Standard
9	PROFIBUS Standard
10	BRANSON-specific data format Default: 0x00 (Bit0 = Bit1 = 0) Bit 0 = 1, Bit 1 = 0 : BIG-ENDIAN (MOTOROLA) Bit 0 = 0, Bit 1 = 1 : LITTLE-ENDIAN
11	BRANSON-specific: Reserved

The respective parameters are selected via the PROFIBUS network configuration function, by means of the PROFIBUS configuration file (*.gsd). To ensure that the Professional Compact can be coupled as flexibly as possible, it is possible to choose the format of the I/O image by means of the "User Parameters". As shown above, you can select between BIG ENDIAN (MOTOROLA) or LITTLE ENDIAN (INTEL).

NOTICE	
	<p>As "Default", neither has been specified. This causes a "User Parameter Error" during startup of the PROFIBUS network. This is intentional. Thus you are forced to enter the desired format explicitly.</p> <p>The data formats shown in this document use the BIG-ENDIAN (MOTOROLA) format.</p>

8.2.2 I/O Image

If the master has recognized, parameterized and configured the DCX Power Supply F-DP on the bus, a cyclic data exchange with the PROFIBUS DATA_EXCHANGE service occurs. This involves exchanging the I/O image between the master and slave in one cycle. The I/O image is divided into two fundamentally different areas:

Process data channel: Only binary signals are read and written via this channel. This channel is processed in each DATA_EXCHANGE cycle. It is used for controlling the DCX Power Supply F-DP, for example for selecting the parameter set and triggering weld or horn functions. This channel has real-time capability.

Communication channel: This channel can be used to exchange welding parameters, status values of completed welding jobs and graphics to the PROFIBUS DP master. The communication follows a defined "handshake process" and stretches across several DATA_EXCHANGE cycles. This channel therefore has no real-time capability.

The I/O image has been divided as follows:

Table 8.6 Communication Channel (PKW)

Communication channel (PKW)				Process data channel (PZD)		Remarks
PKE	IND	PWE	PWE	STW1	STW2	Ma.->Sl. (Out)
				ZSW1	ZSW2	Sl.->Ma. (In)
8 Byte				4 Byte		Consistency

STW1, STW2 Control word 1, 2
ZSW1, ZSW2 Status word 1, 2

The I/O image thus consists of 12 bytes. The consistency specification defines for which parts the content has to be consistent. These conditions are also contained in the PROFIBUS configuration file (*.gsd). They affect the access mechanisms that are possible for the DP master.

8.2.3 Communication Channel (PKW)

The subsequent text describes the communication channel (PKW) for transmitting parameters and status values (data). The following functions are offered:

- Reading/writing test values; to test the implementation of the communication protocol in the super ordinate control system
- Reading version information; to read various hardware/software version numbers
- Reading system information
Power supply type, frequency
Power supply type, power
- RTC (real-time clock) reading/writing
- Error category 1, 2, 5 and "Fieldbus-reading": Reading error categories 1, 2, 5 and "Fieldbus". Errors in this category can occur constantly. Therefore they can also be read independent of the cycle. The "Fieldbus" error category can only be read via another, error-free interface
- External control, visualization (analog values), reading/writing: For visualization, or to structure external control circuits, certain "analog values" (for example frequency, power) can be read continuously, independent of the status sets. Similarly, it is possible to continuously write certain "analog values" (for example the set amplitude value) as external set value specifications, independent of the parameter sets
- Reading/writing a parameter set
- Reading/writing a horn-specific parameter set

- Reading/writing a status set
- Reading/writing a horn-specific status set

The communication channel (PKW) is further divided into the following:

Table 8.7 Subdivisions of the communication channel (PKW)

	Communication channel (PKW)							
	PKE		IND		PWE-HIGH		PWE-LOW	
Contents	Identifier		Index		Param., high word		Param., low word	
	High byte	Low byte	High byte (extend. access)	Low byte	High byte	Low byte	High byte	Low byte
Byte no.	0	1	2	3	4	5	6	7

The identifier (PKE) is further divided into two sections:

Table 8.8 Identifier (PKE) of the communication channel (PKW)

Bit	PKE, high byte								PKE, low byte						
	15	14	13	12	11	10	9	8	7	6	5	4	3	2	1
Contents	AK				PNU										

AK: Instruction/answer code (0...15)

PNU: Parameter number (1...3999)

The respective instruction code (data type, read/write) can be found in the following table, the master writes it in the AK field.

Table 8.9 Answer code - Master > Slave

AK, instruction code Master > Slave	Data type	Function
0	--	No instruction
1	INT / UINT 8	Read
2	IN / UINT16	Read
3	INT / UINT 32	Read
4	AINT / AUINT 8	Read array
5	AINT / AUINT 16	Read array
6	AINT / AUINT 32	Read array
7	INT / UINT 8	Write
8	INT / UINT 16	Write
9	INT / UINT 32	Write
10	AINT / AUINT 8	Write array

Table 8.9 Answer code - Master > Slave

AK, instruction code Master > Slave	Data type	Function
11	AIN / AUINT 16	Write array
12	AIN / AUINT 32	Write array
13	--	Not def.
14	--	Not def.
15	--	Not def.
(A)INT = (Array) Integer		
(A)UINT = (Array) Unsigned Integer		

Furthermore the master assigns the parameter number of the parameter to be read or written to the PNU field. If the data type is an array object, the relevant index additionally has to be entered in the IND field, otherwise IND has to be set to 0. However, for certain parameter numbers, it is possible to select extended access options by means of the IND index field. The High Byte in the IND field serves this purpose. In this case, the actual array index is only transferred in the Low Byte of the IND field, and is thus limited to 255. Even if the data type is not an Array (IND (Low-Byte) = 0), extended access options may be available for certain data numbers. The following table defines the interpretation of IND (High Byte) in these cases:

Table 8.10 IND (High Byte)

IND (High Byte)	Function	Extended access
0x00	(Array) Read	Std. access
0x01 (Bit0)	(Array) Read	"Default Value": Read
0x02 (Bit1)	(Array) Read	"Limit Low": Read
0x04 (Bit2)	(Array) Read	"Limit High" Read
0x00	(Array) Write	Std. access
0x01 (Bit0)	(Array) Write	"Non-volatile (RAM)" Write

If "extended access options" are applied to data numbers that do not support or permit these functions, the corresponding error, "Index erroneous" (see below) is generated. The parameter to be written is written to the "PWE" field. If a parameter has to be read, these fields can be ignored. However, after the instruction has been carried out, they contained the parameters that were read accordingly. To confirm an instruction, the master receives one of the following answer codes in the "AK" field. If this answer code matches the instruction code, the instruction has been carried out successfully.

Table 8.11 Answer Code: Slave > Master

AK, answer code Slave->Master	Data type	Function
0	--	No instruction
1	INT / UINT 8	Read

Table 8.11 Answer Code: Slave > Master

AK, answer code Slave->Master	Data type	Function
2	IN / UINT16	Read
3	INT / UINT 32	Read
4	AINT / AUINT 8	Read array
5	AINT / AUINT 16	Read array
6	AINT / AUINT 32	Read array
7	INT / UINT 8	Write
8	INT / UINT 16	Write
9	INT / UINT 32	Write
10	AINT / AUINT 8	Write array
11	AINT / AUINT 16	Write array
12	AINT / AUINT 32	Write array
13	--	Not def.
14	--	Not def.
15	--	Error
(A)INT = (Array) Integer		
(A)UINT = (Array) Unsigned Integer		

However, it is possible that the slave can also generate errors while an instruction is being carried out. An error is signaled by the respective answer code (= 15). A corresponding error message (error number) is then additionally contained in PKE, low byte (byte 1).

Table 8.12 Error Number PKE, Low Byte

Error number PKE, low byte	Description
1	Undefined instruction code
2	Undefined parameter number
3	Data type erroneous
4	Index erroneous
5	Parameter, value cannot be written
6	Parameter, currently no access right, "Access Token (AT)"
7	Parameter, currently no access right, "Security Level"
8	Parameter, lower limit value not reached
9	Parameter, upper limit value exceeded
10	NV write error -> Category 1 error present

Table 8.12 Error Number PKE, Low Byte

Error number PKE, low byte	Description
11	No access -> Category 1 error present
12	--
13	--
14	--
15	--
16	--
17	--
18	--
...49	--
50	Other errors
51 ... 255	--

8.2.4 Special Functions Within the Communication Channel

To establish the best possible coupling of DCX Power Supply F-DP and PROFIBUS Master, certain mechanisms have to be kept in mind for certain values when the communication channel is being implemented. This includes, amongst others:

- "Get Access Token" and "Put Access Token"
- Reading and writing the real-time clock (RTC)
- Buffering the entire welding parameter set, in order to move or copy it within the DCX Power Supply F-DP
- Setting default values within a welding parameter set
- Buffering the entire status set (welding function)
- Buffering the entire horn parameter set, in order to move or copy it within the DCX Power Supply F-DP
- Buffering the entire status set (horn function)

These special functions, with the necessary commands, are explained in more detail in the appendix.

8.2.5 Writing and reading parameters

The communication process (handshake between master and slave) is as follows: An instruction from the master is always confirmed by an answer from the slave. Therefore there is a fixed handshake process, which has to be observed! This handshake process uses several DATA_EXCHANGE cycles. Originally the instruction code and answer code have to be 0. The master now sets "PWE" (write parameter), "IND" and subsequently "PKE" including "AK". This is recognized by the slave, and the instruction is carried out. The master waits for this to happen, until the slave sets answer code # 0. The "PKE" fields, including the error messages (and the "PWE" (read parameter) fields) have been set by the slave in accordance with the instruction, and can now be evaluated and processed by the master. Subsequently the master sets "AK (instruction code)" = 0 and waits until the slave confirms with "AK (answer code)" = 0. Thus the original status has been restored and a new communication cycle can start. The slave only answers new instructions when it has confirmed the instruction code = 0 with answer code = 0.

Figure 8.2 Writing and reading Parameters

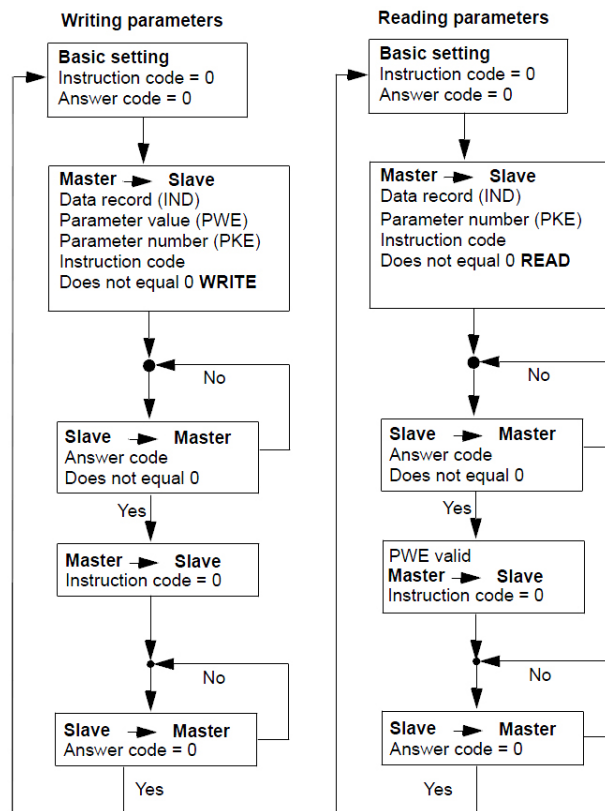

Prior to writing certain parameters, it is necessary to “get” the “Access Token” with the respective command. The “Access Token” is kept until it is “put back” again or until the DCX Power Supply F-DP is separated from the voltage supply. The PKW communication channel is used independent of the process data channel (PZD).

8.2.6 Process Data Channel (PZD Area)

The 8-byte process data area is used to cyclically update the process data. In the direction “master to slave”, control words STW1 and STW2 are used for the transfer. The master can query the slave status by means of status words ZSW1 and ZSW2.

- The process data channel supports the following functions:
- Selection: manual mode or auto mode
- Parameter set - including horn selection
- Controlling the cycle
- Ground detect function
- Amplitude profiling function
- “Error lines” for analyzing the errors of the last cycle

8.2.7 Signal/Control Processes Run Via Process Data Channel

In manual mode, the cycle can be run via the communication channel and the “Start/Stop/Reset” button on the control panel. In auto mode, everything is controlled via the process data channel.

The following are prerequisites for a cycle in automatic mode:

- MA = AUTO Automatic mode selected
- PSN0..PSN4 = XX Parameter set number selected

A category 2 error does not influence the processing of the cycle. However, if a corresponding error is present, the cycle is stopped right at the beginning. This occurs because this error can be set or deleted independent of the power supply controller.

If the prerequisites above have been met, the DCX Power Supply F-DP is OFF. Setting the "ON / STW2" bit switches it to the ON state (ultrasonic output + hold time). The appropriate parameters within the selected parameter set for the respective function is also adopted at this point in time. The complete "STW2 / Low-Byte" is evaluated simultaneously. Within "STW2 / Low-Byte", either the "STW2 / FCT" or the "STW2 / SFCT" bit has to be set, in accordance with the desired cycle for the welding and horn function. This determines the actual function of the cycle.

If the "STW2 / SFCT" bit has been set, the following bits are evaluated additionally: "STW2 / SFCT2..SFCT0" (horn-specific function, $SFCT2 = 2^2..SFCT0=2^0$). This determines the desired horn-specific function.

Welding and horn-specific functions have to be stopped - as per the respective parameter assignment - either by the PLC (continuous welding) or the power supply, depending on the operating mode (for example: welding time expired, energy -> energy reached). In the subsequent text, this is called "PLC Stop" or "Power Supply Stop". This information is provided by the Stop mode "SM / ZSW2" bit from the start of the ON state onwards.

The various processes for the two stop modes are as follows:

Signal flow, PLC stop ("SM / ZSW2" = 1):

If the PLC ends the cycle (continuous welding), the "ON / STW2" bit has to be reset. The DCX Power Supply F-DP thus cancels the cycle and switches to OK or ERROR state. Here the "OK / ZSW2" or "ER / ZSW2" bits are valid. This can be used to analyze the previous cycle. Subsequently the signal analysis has to be reset by setting the "RST / STW2" bit (edge-triggered). This switches the system to the OFF state. If internal errors are present, they are reset and the "OK / ZSW2" and "ER / ZSW2" bits are deleted. Then the system is ready for a new cycle.

If a power supply error occurs during the cycle, the "ER / ZSW2" bit signals this fact. Subsequently the "ON / STW2" bit has to be reset, the error has to be processed and, again, the analysis of these signals has to be reset with the "RST / STW2" bit. This switches the system to the OFF state.

Signal flow, power supply stop ("SM / ZSW2" = 0):

If the cycle has been completed, for example by means of a time or energy switch-off, or if an error occurred during the ON state, the system switches to OK or ERROR state. While the DCX Power Supply F-DP is in one of these states, the "OK / ZSW2" or "ER / ZSW2" bit is valid. This can be used to analyze the previous cycle. Subsequently the signal analysis has to be reset by setting the "RST / STW2" bit (edge-triggered). This switches the system to the OFF state. If internal errors are present, they are reset and the "OK / ZSW2" and "ER / ZSW2" bits are deleted. Then the system is ready for a new cycle.

In both processes, the OFF state is signaled by the "OFF / ZSW2" bit, the ON state by the "ON / ZSW2" bit, the OK state by the "OK / ZSW2" bit and the ERROR state by the "ER / ZSW2" bit.

A "handshake" with the superordinate controller can and should only be realized by means of the "OK / ZSW2" and "ER / ZSW2" bits.

The "OFF / ZSW2" and "ON / ZSW2" bits are not absolutely required for the control functions. They could be used in the realization of special functions.

If the prerequisites mentioned earlier are not met (any more), the process - including the switch to the OFF state - can be maintained. However, it is only possible to exit the OFF

state when all prerequisites have been met. This is reported by the corresponding return messages.

The states listed above are indicated by the respective LEDs on the control panel.

8.3 Implicit Messaging

8.3.1 DCX Inputs/PLC Outputs (8 bytes)

Table 8.13 DCX Inputs/PLC Outputs (8 bytes)

Data	Description	Data Type	Access	Unit	Notes
0	STW1 (STW Word 1)	UINT16	W	-	See Table 8.14 and Table 8.17
1	SWT2 (STW Word 2)			-	
2	External Amplitude			%	
3	Frequency Offset			Hz	

8.3.1.1 Control Word (STW1)

Table 8.14 Control Word (STW1)

	Bit	Name	Description	Notes
	0	RES	Reserved	Not used
	1	ES	Emergency Stop	1=Emergency Stop
	2	RES	Reserved	Not used
	3	RES	Reserved	Not used
	4	HFS0	Stack Preset Number 0	See Table 8.15 HFS Bit (Control Word) .
	5	HFS1	Stack Preset Number 1	
	6	HFS2	Stack Preset Number 2	
	7	HFS3	Stack Preset Number 3	
	<p>NOTICE</p> <p>HFS stack presets numbers are feedback inputs to indicate RF relay switching state. This is used only in stack sequencing applications. Set HFS to 0 if not using stack sequencing.</p>			
STW1	8	PSN0	Weld Preset Number 0	See Table 8.16 PSN Bit (Control Word) .
	9	PSN1	Weld Preset Number 1	
	10	PSN2	Weld Preset Number 2	
	11	PSN3	Weld Preset Number 3	
	12	PSN4	Weld Preset Number 4	
	<p>NOTICE</p> <p>Preset 0 is reserved for the running preset. When a preset number is recalled, it is copied to Preset 0 and becomes the running preset.</p>			
	13	RES	Reserved	Not used
	14	MA	Manual/Auto	Set and leave to 1 for implicit messaging control Set to 0 for discrete I/O control
	15	RES	Reserved	Not used

HFS Bit (Control Word)

Table 8.15 HFS Bit (Control Word)

HFS3	HFS2	HFS1	HFS0	Stack Selected
0	0	0	0	No stack change
0	0	0	1	1 (factory default)
0	0	1	0	2
0	0	1	1	3
0	1	0	0	4
0	1	0	1	5
0	1	1	0	6
0	1	1	1	7
1	0	0	0	8
1	0	0	1	9
1	0	1	0	10
1	0	1	1	11
1	1	0	0	12
1	1	0	1	13
1	1	1	0	14
1	1	1	1	15

PSN Bit (Control Word)

Table 8.16 PSN Bit (Control Word)

PSN4	PSN3	PSN2	PSN1	PSN0	Preset Selected
0	0	0	0	0	Previous preset
0	0	0	0	1	1
0	0	0	1	0	2
0	0	0	1	1	3
0	0	1	0	0	4
0	0	1	0	1	5
0	0	1	1	0	6
0	0	1	1	1	7
0	1	0	0	0	8
0	1	0	0	1	9

Table 8.16 PSN Bit (Control Word)

PSN4	PSN3	PSN2	PSN1	PSN0	Preset Selected
0	1	0	1	0	10
0	1	0	1	1	11
0	1	1	0	0	12
0	1	1	0	1	13
0	1	1	1	0	14
0	1	1	1	1	15
1	0	0	0	0	16
1	0	0	0	1	17
1	0	0	1	0	18
1	0	0	1	1	19
1	0	1	0	0	20
1	0	1	0	1	21
1	0	1	1	0	22
1	0	1	1	1	23
1	1	0	0	0	24
1	1	0	0	1	25
1	1	0	1	0	26
1	1	0	1	1	27
1	1	1	0	0	28
1	1	1	0	1	29
1	1	1	1	0	30
1	1	1	1	1	31

8.3.1.2 Control Word (STW2)

Table 8.17 Control Word (STW2)

	Bit	Name	Description	Notes
STW2	0	FCT	Weld Function	1 = To run ultrasonics in normal mode
	1	SFCT	Stack Function	See Table 8.23
	2	SFCT0	Stack Function 0	
	3	SFCT1	Stack Function 1	
	4	SFCT2	Stack Function 2	
	5	RES	Reserved	Not used
	6	MCLR	Memory Clear	1 = Memory offset will be set to 0
	7	RES	Reserved	Not used
	8	RST	Reset	1 = Reset
	9	ON	Run Ultrasonics	1 = Will turn on ultrasonics based on combination of SFCT or FCT bits. See table below.
	10	RES	Reserved	Not used
	11	RES	Reserved	
	12	GNDDT	Ground Detect	1 = Ground has been detected
	13	APROF	Amplitude Profile	1 = Switch from amplitude 1 to amplitude 2
	14	RES	Reserved	Not used
15	RES	Reserved		

8.3.2 DCX Outputs/PLC Inputs (20 bytes)

Table 8.18 DCX Outputs/PLC Inputs (20 bytes)

Data	Description	Data Type	Access	Unit	Notes
0	Reserved	UINT16	R		
1	Reserved				
2	ZSW1 (ZSW Word 1)			-	See Table 8.19 and Table 8.22
3	ZSW2 (ZSW Word 2)			-	
4	Nominal Amplitude Set			%	
5	Amplitude Output			%	
6	Current			%	
7	Power	%			
8	Phase	INT16		°	
9	PWM	UINT16		%	
10	Frequency			Hz	
11	Temperature		C		

8.3.2.1 Status Word (ZSW1)

Table 8.19 Status Word (ZSW1)

	Bit	Name	Description	Notes
ZSW1	0	NO-B	Non Cycle Overload Group B	1 = Non cycle overload has occurred
	1	ES	Emergency Stop Active	1 = Emergency stop active
	2	TEE	Future Use	Not used
	3	HFSE		
	4	HFS0	Stack Preset Number 0 Status	See Table 8.20 HFS Bit (Status Word) .
	5	HFS1	Stack Preset Number 1 Status	
	6	HFS2	Stack Preset Number 2 Status	
	7	HFS3	Stack Preset Number 3 Status	
	8	PSN0	Weld Preset Number 0 Active	See Table 8.21 PSN Bit (Status Word) .
	9	PSN1	Weld Preset Number 1 Active	
	10	PSN2	Weld Preset Number 2 Active	
	11	PSN3	Weld Preset Number 3 Active	
	12	PSN4	Weld Preset Number 4 Active	
	13	PSCA	Preset Change Complete	1 = Preset change complete
	14	MA	Manual/Auto Mode Active	1 = Auto Mode
15	OL-0	Overload Group 0	1 = Overload has occurred	

HSF Bit (Status Word)

Table 8.20 HFS Bit (Status Word)

HFS3	HFS2	HFS1	HFS0	Stack Active
0	0	0	0	Not valid
0	0	0	1	1
0	0	1	0	2
0	0	1	1	3
0	1	0	0	4
0	1	0	1	5
0	1	1	0	6
0	1	1	1	7
1	0	0	0	8
1	0	0	1	9
1	0	1	0	10
1	0	1	1	11
1	1	0	0	12
1	1	0	1	13
1	1	1	0	14
1	1	1	1	15

PSN Bit (Status Word)

Table 8.21 PSN Bit (Status Word)

PSN4	PSN3	PSN2	PSN1	PSN0	Preset Active
0	0	0	0	0	No preset active
0	0	0	0	1	1
0	0	0	1	0	2
0	0	0	1	1	3
0	0	1	0	0	4
0	0	1	0	1	5
0	0	1	1	0	6
0	0	1	1	1	7
0	1	0	0	0	8
0	1	0	0	1	9

Table 8.21 PSN Bit (Status Word)

PSN4	PSN3	PSN2	PSN1	PSN0	Preset Active
0	1	0	1	0	10
0	1	0	1	1	11
0	1	1	0	0	12
0	1	1	0	1	13
0	1	1	1	0	14
0	1	1	1	1	15
1	0	0	0	0	16
1	0	0	0	1	17
1	0	0	1	0	18
1	0	0	1	1	19
1	0	1	0	0	20
1	0	1	0	1	21
1	0	1	1	0	22
1	0	1	1	1	23
1	1	0	0	0	24
1	1	0	0	1	25
1	1	0	1	0	26
1	1	0	1	1	27
1	1	1	0	0	28
1	1	1	0	1	29
1	1	1	1	0	30
1	1	1	1	1	31

8.3.2.2 Status Word (ZSW2)

Table 8.22 Status Word (ZSW2)

	Bit	Name	Description	Notes
ZSW2	0	SE-2	Setup Group 2	1 = Setup alarm has occurred
	1	CM-3	Cycle Modified Group 3	1 = Cycle modified alarm has occurred
	2	WA-4	Warning Group 4	1 = Warning alarm has occurred
	3	EQ-6	Equipment Failure Group 6	1 = Equipment failure alarm has occurred
	4	NC-7	No Cycle Group 7	1 = No cycle alarm has occurred
	5	CF-8	Communication Failure Group 8	1 = Communication alarm has occurred
	6	HW-A	Hardware Group A	1 = Hardware alarm has occurred
	7	CU-1	Cutoff Group 1	1 = Cutoff alarm has occurred
	8	TP-9	Future Use	Not used
	9	SM	Future Use	Not used
	10	OFF	Ultrasonics Off and DCX Ready	1 = Ultrasonics off and DCX ready
	11	ON	Ultrasonics Active	1 = Ultrasonics active
	12	OK	End of Weld Cycle Without Error	1 = End cycle without error
	13	LM-5	Limit Group 5	1 = Limit alarm has occurred
	14	MCLR	Memory Clear	1 = Memory offset will be set to 0
15	RES	Reserved	Not used	

8.3.2.3 Stack Function

Table 8.23 Stack Function

Bit	Name	Test	Scan	Seek
STW2/1	SFCT	1	1	1
STW2/2	SFCT0	1	0	0
STW2/3	SFCT1	0	1	0
STW2/4	SFCT2	0	0	0

8.3.3 Implicit Message for Run

Table 8.24 Implicit Message for Run

Value	STW1 Bit															
16384d	15	14	13	12	11	10	9	8	7	6	5	4	3	2	1	0
	0	1	0	0	0	0	0	0	0	0	0	0	0	0	0	0
Value	STW2 Bit															
513d	15	14	13	12	11	10	9	8	7	6	5	4	3	2	1	0
	0	0	0	0	0	0	0	1	0	0	0	0	0	0	0	1

8.3.4 Implicit Message for Seek

Table 8.25 Implicit Message for Seek

Value	STW1 Bit															
16384d	15	14	13	12	11	10	9	8	7	6	5	4	3	2	1	0
	0	1	0	0	0	0	0	0	0	0	0	0	0	0	0	0
Value	STW2 Bit															
514d	15	14	13	12	11	10	9	8	7	6	5	4	3	2	1	0
	0	0	0	0	0	0	0	1	0	0	0	0	0	0	1	0

8.3.5 Implicit Message for Scan

Table 8.26 Implicit Message for Scan

Value	STW1 Bit															
16384d	15	14	13	12	11	10	9	8	7	6	5	4	3	2	1	0
	0	1	0	0	0	0	0	0	0	0	0	0	0	0	0	0
Value	STW2 Bit															
522d	15	14	13	12	11	10	9	8	7	6	5	4	3	2	1	0
	0	0	0	0	0	0	0	1	0	0	0	0	1	0	1	0

8.3.6 Implicit Message for Reset

Table 8.27 Implicit Message for Reset

Value	STW1 Bit															
16384d	15	14	13	12	11	10	9	8	7	6	5	4	3	2	1	0
	0	1	0	0	0	0	0	0	0	0	0	0	0	0	0	0
Value	STW2 Bit															
256d	15	14	13	12	11	10	9	8	7	6	5	4	3	2	1	0
	0	0	0	0	0	0	0	0	1	0	0	0	0	0	0	0

Chapter 9: Maintenance

9.1	General Maintenance Considerations	148
9.2	DCX Power Supply F-DP Preventive Maintenance	150
9.3	Recommended Spare Stock	155
9.4	Circuit Diagram.	160
9.5	Troubleshooting	161
9.6	Cold Start Procedure	164

9.1 General Maintenance Considerations

WARNING	High Voltage Hazard
	<p>Power supplies produce high voltage. To avoid the possibility of an electrical shock, you should always power down your system prior to repairing any portion of it.</p>

CAUTION	General Warning
	<p>When performing maintenance on the welder, make sure that no other automated systems are active.</p>

NOTICE	
	<p>There are no customer replaceable components inside the power supply. Have all servicing done by a qualified Branson technician.</p>

NOTICE	
	<p>When returning printed circuit boards, make sure to enclose them in an anti-static package.</p>

NOTICE	
	<p>Connectors may not be keyed and wires may not be color-coded. Therefore, when disconnecting cables and wires, label them so you can reconnect them properly.</p>

NOTICE



To prevent circuit damage from electrostatic discharge, always service the power supply on a static-dissipative surface, while wearing a properly grounded wrist strap.

9.2 DCX Power Supply F-DP Preventive Maintenance

The following preventive measures help assure long term operation of your Branson DCX Power Supply F-DP equipment.

9.2.1 Periodically Clean the Equipment

NOTICE	
	Use only anti-static vacuum cleaners to prevent damage from electrostatic discharge to your power supply.

Air is continuously drawn into the power supply. Periodically disconnect the unit from power, remove the cover and vacuum out any accumulated dust and debris. Remove material adhering to:

- The fan blades and motor
- Power supply heat sink cooling fins
- Transformers
- Circuit boards
- Cooling intake vents
- Exhaust ports

External covers may be cleaned with a damp sponge or cloth using a solution of mild soap and water. Do not allow cleaning solution to enter the unit.

To prevent rust in areas of high humidity, exposed steel surfaces, may require a very light film of rust preventing oil, such as WD-40[®]*

* WD-40 is a registered trademark of WD-40 Manufacturing Company.

9.2.2 Recondition the Stack (Converter, Booster, and Horn)

NOTICE	
	Never clean the converter-booster-horn stack mating surfaces by using a buffing wheel or by filing.

Welding system components work most efficiently when the converter-booster-horn stack mating surfaces are flat, in solid contact, and free from fretting corrosion. Poor contact between mating surfaces wastes power output, makes tuning difficult, increases noise and heat, and may cause damage to the converter.

For standard 20 kHz and 30 kHz products, a Branson Mylar polyester film washer should be installed between the horn and booster, and horn and converter. Replace the washer if

torn or perforated. Stacks using Mylar plastic film washers should be inspected every three months.

Stacks used with silicone grease, as with certain 20 kHz, 30 kHz and all 40 kHz products, should be periodically reconditioned to eliminate fretting corrosion. A stack using silicone grease should be inspected every two weeks for corrosion. When experience is gained for specific stacks, the inspection interval can be adjusted to a longer or shorter period as required.

Stack Reconditioning Procedure

To recondition stack mating surfaces, take the following steps:

Table 9.1 Stack Reconditioning Procedure

Step	Action
1	Disassemble the converter-booster-horn stack and wipe the mating surfaces with a clean cloth or paper towel.
2	Examine all mating surfaces. If any mating surface shows corrosion or a hard, dark deposit, recondition it.
3	If necessary, remove the threaded stud from the part.
4	Tape a clean sheet of #400 (or finer) grit emery cloth to a clean, smooth, flat surface (such as a sheet of plate glass), as in Figure 9.1 Reconditioning Stack Mating Surfaces .
5	Place the interface surface on the emery cloth. Grasp the part at the lower end, with your thumb over the spanner-wrench hole, and lap the part in a straight line across the emery cloth. Do not apply downward pressure — the weight of the part alone provides sufficient pressure.
6	Lap the part, two or three times, in the same direction against the emery cloth. (See Figure 9.1 Reconditioning Stack Mating Surfaces .)
7	Rotate the part 120 degrees, placing your thumb over the spanner-wrench hole, and repeat the lapping procedure in step 6.
8	Rotate the part another 120 degrees to the next spanner-wrench hole, and repeat the lapping procedure in step 6.
9	Re-examine the mating surface. If necessary, repeat steps 2-5 until you remove most of the contaminant. Remember, this should not require more than two to three complete rotations for an aluminum horn or booster; a titanium component may require more rotations.
10	<p>Before re-inserting a threaded stud in an aluminum booster or horn:</p> <p>Using a file card or wire brush, clean any aluminum bits from the knurled end of the stud.</p> <p>Using a clean cloth or towel, clean the threaded hole.</p> <p>Examine the knurled end of the stud. If worn, replace the stud. Also, examine the stud and threaded hole for stripped threads.</p> <p>NOTICE</p> <p>Threaded studs cannot be reused in titanium horns or boosters. Replace all studs in these components.</p>

Table 9.1 Stack Reconditioning Procedure

Step	Action
11	Assemble and install the stack.

Figure 9.1 Reconditioning Stack Mating Surfaces

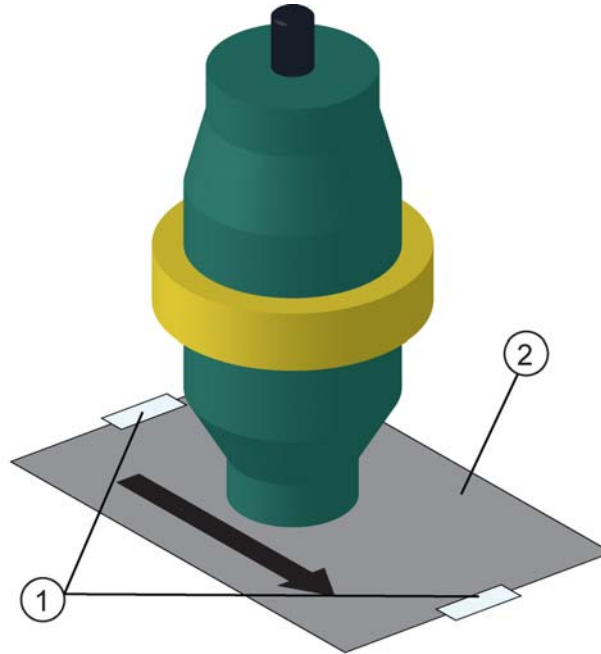

Table 9.2 Reconditioning Stack Mating Surfaces

Item	Description
1	Tape
2	#400 Emery Cloth

9.2.3 Stack Torque Values

Table 9.3 Stack Torque Values

Frequency	Torque
20 kHz	220 in·lb (25 N·m)
30 kHz	185 in·lb (21 N·m)
40 kHz	95 in·lb (11 N·m)

For a 20 kHz System

Table 9.4 Stack Reassembly for a 20 kHz System

Step	Action
1	Clean the mating surfaces of the converter, booster, and horn. Remove any foreign material from the threaded holes.
2	Install the threaded stud into the top of the booster. Torque to 450 in·lb (50.84 N·m). If the stud is dry, apply 1 or 2 drops of a light lubricating oil before installing.
3	Install the threaded stud into the top of the horn. Torque to 450 in·lb (50.84 N·m). If the stud is dry, apply 1 or 2 drops of a light lubricating oil before installing.
4	Install a single Mylar plastic film washer (matching the size of the washer to the stud) to each interface.
5	Assemble the converter to the booster and the booster to the horn.
6	Torque to 220 in·lb (24.85 N·m) at each interface.

For a 30 kHz System

Table 9.5 Stack Reassembly for a 30 kHz System

Step	Action
1	Clean the mating surfaces of the converter, booster, and horn. Remove any foreign material from the threaded holes.
2	Install the threaded stud into the top of the booster. Torque to 290 in·lb (32.76 N·m). If the stud is dry, apply 1 or 2 drops of a light lubricating oil before installing.
3	Install the threaded stud into the top of the horn. Torque to 290 in·lb (32.76 N·m). If the stud is dry, apply 1 or 2 drops of a light lubricating oil before installing.
4	Install a single Mylar plastic film washer (matching the size of the washer to the stud) to each interface.
5	Assemble the converter to the booster and the booster to the horn.
6	Torque to 185 in·lb (21 N·m) at each interface.

For a 40 kHz System

Table 9.6 Stack Reassembly for a 40 kHz System

Step	Action
1	Clean the mating surfaces of the converter, booster, and horn. Remove any foreign material from the threaded holes.
2	Apply a drop of Loctite® * 290 threadlocker (or equivalent) to the studs for the booster and horn.
3	Install the threaded stud into the top of the booster. Torque to 70 in·lb (7.91 N·m). Remove excess Loctite 290 threadlocker from the booster face and let cure for 30 minutes.
4	Install the threaded stud into the top of the horn. Torque to 70 in·lb (7.91 N·m). Remove excess Loctite 290 threadlocker from the horn face and let cure for 30 minutes.
5	Coat each interface surface with a thin film of silicon grease - but do not apply silicon grease to a threaded stud or tip.
6	Torque to 95 in·lb (10.73 N·m) at each interface.

* Loctite is a registered trademark of Henkel Corporation, U.S.A.

9.2.4 Stud Torque Values

Table 9.7 Stud Torque Values

Used on	Stud Size	Torque	EDP #
20 kHz	1/2 in x 20 x 1-1/4 in	450 in·lb, 50.84 N·m	100-098-370
	1/2 in x 20 x 1-1/2 in		100-098-123
30 kHz	3/8 in x 24 x 1 in	290 in·lb, 32.76 N·m	100-298-170R
40 kHz*	M8 x 1.25	70 in·lb, 7.91 N·m	100-098-790

* Add a drop of Loctite 290 threadlocker to the stud. Torque and let cure for 30 minutes before using.

9.3 Recommended Spare Stock

This section provides lists of replacement parts, system cables, and suggested spares.

9.3.1 System Cables

You can order the following cables:

Table 9.8 DCX Power Supply F-DP System Cables

P/N	Description
100-240-383	Cable, RF 8 ft (2.5 m)
100-240-384	Cable, RF 15 ft (4.5 m)
100-240-385	Cable, RF 25 ft (7.5 m)
100-240-387	Cable, RF right angle 8 ft (2.5 m)
100-240-388	Cable, RF right angle 15 ft (4.5 m)
100-240-389	Cable, RF right angle 25 ft (7.5 m)
100-240-391	Cable, RF adaptor for CR20 converter 3 ft (0.9 m)
100-240-392	Cable, User I/O 25 ft (7.5 m)
100-240-393	Cable, User I/O 50 ft (15 m)
200-240-396	Cable Ethernet Cat 5e 7 ft (2.1 m)
100-240-397	Cable, RF adaptor for 4TR converter 3 ft (0.9 m)

9.3.2 Suggested Spares

Table 9.9 Suggested Spares

Description	EDP#	1-4 Units	6-12 Units	14+ Units
Converter	Refer to Table 9.10 Converters Compatible with the DCX Power Supply F-DP.	0	1	2
Booster	Refer to Table 9.11 DCX Power Supply F-DP Compatible Boosters.	0	1	2
Horn	As Ordered	1	1	2

Table 9.9 Suggested Spares

Description	EDP#	1-4 Units	6-12 Units	14+ Units
Studs	Refer to Table 9.12 Other Items used with the DCX Power Supply F-DP.	4	6	8
Mylar Plastic Film Washer Kit	Refer to Table 9.12 Other Items used with the DCX Power Supply F-DP.	1	1	1

9.3.3 Converters Compatible with the DCX Power Supply F-DP

Table 9.10 Converters Compatible with the DCX Power Supply F-DP

Where used	Model	Connector	Part Number
20 kHz / 1250 W 20 kHz / 2500 W 20 kHz / 4000 W	CR-20*	3-pin MS connector	101-135-060R
	CR-20S	SHV connector	125-135-115R
	CR-20C	SHV connector with 3 ft (0.9 m) cable	159-135-210R
	CH-20S (932 AH SPL)	SHV connector	159-135-075R
	CH-20C	SHV connector with 3 ft (0.9 m) cable	159-135-211R
	CS-20S	SHV connector	159-135-138R
	CS-20C	SHV connector with 3 ft (0.9 m) cable	159-135-209R
30 kHz / 750 W 30 kHz / 1500 W	CR-30S	SHV connectors	101-135-081R
	CR-30C	SHV connector with 3 ft (0.9 m) cable	159-135-213R
	CH-30S	SHV connector	101-135-071R
	CH-30C	SHV connector with 3 ft (0.9 m) cable	159-135-214R
	CS-30S	SHV connector	159-135-110R
	CS-30C	SHV connector with 3 ft (0.9 m) cable	159-135-212R

Table 9.10 Converters Compatible with the DCX Power Supply F-DP

Where used	Model	Connector	Part Number
40 kHz / 400 W 40 kHz / 800 W	4TR	3-pin MS connector	101-135-042R
	4TP	SHV connector (platen mount)	101-135-068R
	CR-40S (4TH)	SHV connector	101-135-067R
	CR-40C	SHV connector with 3 ft (0.9 m) cable	159-135-215R

* Requires a special adaptor cable. See [Table 9.8 DCX Power Supply F-DP System Cables](#).

9.3.4 DCX Power Supply F-DP Compatible Boosters

Table 9.11 DCX Power Supply F-DP Compatible Boosters

Type of Booster	Description	Part Number
Solid Mount (1/2-20 horn stud) 20 kHz	Titanium, 1:0.6 (Purple)	101-149-095
	Titanium, 1:1 (Green)	101-149-096
	Titanium, 1:1.5 (Gold)	101-149-097
	Titanium, 1:2 (Silver)	101-149-098
	Titanium, 1:2.5 (Black)	101-149-099
Solid Mount (M8 x 1.25 horn stud) 40 kHz	Titanium, 1:0.6 (Purple)	109-041-178
	Titanium, 1:1 (Green)	109-041-177
	Titanium, 1:1.5 (Gold)	109-041-176
	Titanium, 1:2 (Silver)	109-041-175
	Titanium, 1:2.5 (Black)	109-041-174
Standard Series (1/2-20 horn stud) 20 kHz	Aluminum, 1:0.6 (Purple)	101-149-055
	Aluminum, 1:1 (Green)	101-149-051
	Aluminum, 1:1.5 (Gold)	101-149-052
	Aluminum, 1:2 (Silver)	101-149-053
	Titanium, 1:0.6 (Purple)	101-149-060
	Titanium, 1:1 (Green)	101-149-056
	Titanium, 1:1.5 (Gold)	101-149-057
	Titanium, 1:2 (Silver)	101-149-058
Titanium, 1:2.5 (Black)	101-149-059	

Table 9.11 DCX Power Supply F-DP Compatible Boosters

Type of Booster	Description	Part Number
Standard Series (3/8-24 horn stud) 30 kHz	Titanium, 1:2.5 (Black)	101-149-103
	Titanium, 1:2 (Silver)	101-149-104
	Titanium, 1:1.5 (Gold)	101-149-105
	Titanium, 1:1 (Green)	101-149-106
Standard Series (M8 x 1.25 horn stud) 40 kHz	Aluminum, 1:0.6 (Purple)	101-149-087
	Aluminum, 1:1 (Green)	101-149-079
	Aluminum, 1:1.5 (Gold)	101-149-080
	Aluminum, 1:2 (Silver)	101-149-081R
	Aluminum, 1:2.5 (Black)	101-149-082
	Titanium, 1:1 (Green)	101-149-085
	Titanium, 1:1.5 (Gold)	101-149-086
	Titanium, 1:2 (Silver)	101-149-083
	Titanium, 1:2.5 (Black)	101-149-084

9.3.5 Other Items used with the DCX Power Supply F-DP

Table 9.12 Other Items used with the DCX Power Supply F-DP

Product	Description	Part No.
Silicone grease	For use with 40 kHz systems	101-053-002
Mylar Plastic Film Washers (for 20 kHz systems)	Kit, 10 each (1/2 in. and 3/8 in.)	100-063-357
	Kit, 150 each (1/2 in.)	100-063-471
	Kit, 150 each (3/8 in.)	100-063-472
Mylar Plastic Film Washers (for 30 kHz systems)	Kit, 10 each (3/8 in.)	100-063-632
	Kit, 150 each (3/8 in)	100-063-712
Tool Kit	20 kHz (spanner wrench and 10 pc washer kit)	101-063-208R
	30 kHz (spanner wrench and 10 pc washer kit)	101-063-636R
	40 kHz (spanner wrench and silicone grease)	101-063-176R
Spanner wrench	20 kHz	101-118-039
	30 kHz	201-118-033
	40 kHz	201-118-024

Table 9.12 Other Items used with the DCX Power Supply F-DP

Product	Description	Part No.
Studs	1/2-20 x 1-1/4 (titanium horns)	100-098-370
	1/2-20 x 1-1/2 (aluminum horns, 20 kHz boosters)	100-098-123
	3/8-24 x 1 (30 kHz titanium horns and boosters)	100-298-170
	M-8 x 1.25 (40 kHz horns and boosters)	100-098-790
Fan Filter*	For small size units (400 W, 750 W, and 800 W)	101-063-936
	For medium size units (1250 W, and 1500 W)	101-063-935
	For large size units (2500 W, and 4000 W)	101-063-934
Connector Block	Detachable connector block	200-029-1081
Top Mounting Plate	Top mounting plate for vertical units.	100-079-462
Bottom Mounting Plate	Bottom mounting plate for vertical units.	100-079-463

* When using a fan filter on a DCX Power Supply F-DP, the maximum output power must be derated by 10%.

9.4 Circuit Diagram

Figure 9.2 Interconnect Diagram, Power Supply

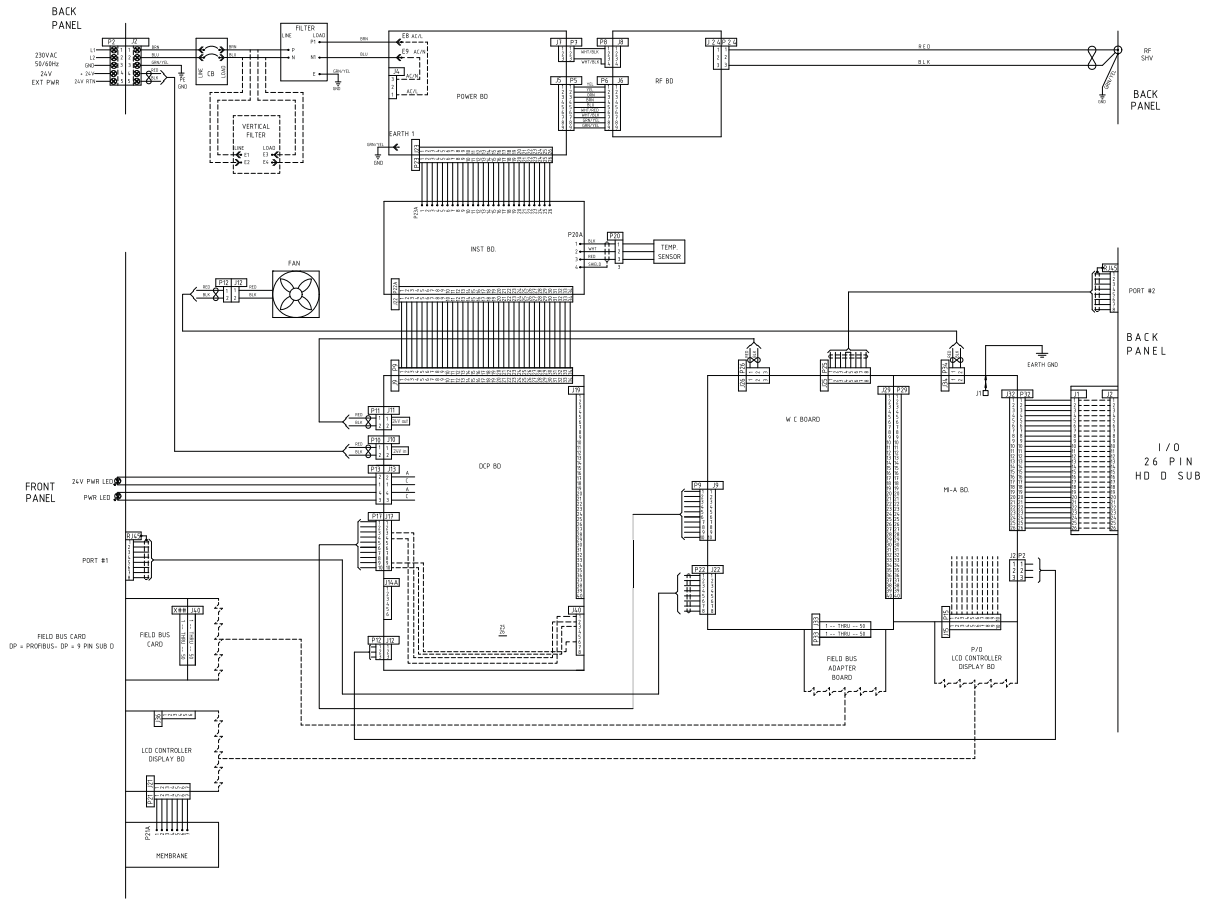

9.5 Troubleshooting

If you have a problem operating the DCX Power Supply F-DP, take the following steps:

Table 9.13 Troubleshooting

Step	Action
1	Make sure the converter-booster-horn stack is properly assembled and installed.
2	For instructions on reconditioning stack component surfaces, refer to 9.2.2 Recondition the Stack (Converter, Booster, and Horn) .
3	If you need additional help, call your local Branson representative, refer to 1.4 How to Contact Branson .

NOTICE	
	DCX Power Supply F-DP should be serviced only by qualified technicians using Branson-approved test and repair equipment, repair procedures, and replacement parts. Unauthorized attempts at repair or modification of the power supply will void the warranty.

9.5.1 Common Electrical Problems

NOTICE	
	If the circuit breaker fails more than once, this usually indicates that another component has failed. Continue troubleshooting other components.

Table 9.14 Troubleshooting Common Electrical Problems

Problem	Check	Solution
Main circuit breaker trips when plugging the power supply into an electrical outlet.	Inspect line connection cables.	If failed, replace.
Main circuit breaker trips during weld cycle.	Check current rating of the main circuit breaker.	If failed, replace.
Main circuit breaker fails during power up.	Check main circuit breaker current rating.	If incompatible, replace main circuit breaker.

Table 9.14 Troubleshooting Common Electrical Problems

Problem	Check	Solution
When touching a component of the weld system, you get a slight electrical shock.	Ensure the Ground cable is connected properly.	N/A
	Inspect the line cables.	If failed, repair or replace.
Fan does not operate when is tested on the Diagnostic User I/O Web Page.	Fan motor has failed.	Return for repair.

9.5.2 Ultrasonic Power Problems

Table 9.15 Troubleshooting Ultrasonic Power Problems

Problem	Check	Solution
Ultrasonic power delivered to horn; no indication on bar graph.	Check connector cables, replace if failed.	Replace defective cables.
	Test power supply.	See 7.6 Ultrasonics Test Procedure .
No ultrasonic power generated when Test key pressed; no Alarm indicator.	Failed or missing stack.	Replace.
	RF cable unplugged or failed; replace if failed.	Plug in or replace.
	Test power supply (7.6 Ultrasonics Test Procedure).	If defective, send unit for repair.
Unable to adjust amplitude using the front panel keypad.	Register setting configured to "External Amplitude Control"	Reset if required, See 7.4 Configuring the Power Supply Registers .
Unable to remote control.	User I/O cable	Repair or replace.
	Customer's switching device	Test/inspect/repair/replace.

9.5.3 Weld Cycle Problems

Table 9.16 Troubleshooting Weld Cycle Problems

Problem	Check	Solution
Full ultrasonic power not delivered.	Unsuitable horn or booster selection.	Contact Branson Applications Lab
	Plastic part material varies.	
	Mold release lubricant in weld area.	
	Unsuitable joint design.	
	Unsuitable or misaligned part fixture.	
	Amplitude setting	Adjust if required.
No ultrasonic power passed to horn.	Power supply overheating; check fan and vents.	If defective, send unit for repair.
Alarm indicator illuminates when you press the Test key or during the weld cycle.	Check converter-booster-horn stack interface for fretting corrosion.	See 9.2.2 Recondition the Stack (Converter, Booster, and Horn) .
	Check for loose or failed horn converter or booster.	Tighten or replace as needed.
	Check for loose or failed horn or booster stud.	
	Failed RF cable	Replace if failed.
Excessively warm horn, booster, and converter; occasional overloads.	Check converter-booster-horn stack mating surfaces for fretting corrosion.	See 9.2.2 Recondition the Stack (Converter, Booster, and Horn) .
	Be certain proper cooling has been provided.	If defective, send unit for repair.

9.6 Cold Start Procedure

The power supply internal memory stores the system default settings and the registers that you set. It also provides temporary storage to support the power supply internal functions. A cold start clears and restores all the power supply settings back to the original factory defaults. It is not necessary to perform a cold start during normal operation and servicing, but you might find a cold start helpful when:

- You suspect the system is not operating properly
- You want to make a new setup
- Some system memory registers, such as Software version, will not be cleared by this Cold Start procedure

9.6.1 Performing a Cold Start

NOTICE	
	<p>Using the Cold Start procedure will erase the current Amplitude Setting, the IP address and some of the Registers that you set. Be sure you have a record of your setup if you want to retain it or use the system backup feature from the DCX Power Supply F-DP Web Page Interface.</p>

Table 9.17 Steps to Perform a Cold Start

Step	Action
1	Turn off the power supply.
2	Connect together pins 4 and 10 on the 26-pin User I/O Connector.
3	Turn on the power supply.
4	After the power up sequence ends, turn off the power supply
5	Disconnect pins 4 and 10 of the 26-pin on User I/O Connector.

Appendix A: Alarms

A.1	Overload Alarms (Group 0)	166
A.2	Cutoff Alarms (Group 1)	168
A.3	Setup Alarms (Group 2)	169
A.4	Cycle Modified Alarms (Group 3)	170
A.5	Warning Alarms (Group 4)	171
A.6	Limit Alarms (Group 5)	172
A.7	Equipment Failure Alarms (Group 6)	173
A.8	No Cycle Alarms (Group 7)	175
A.9	Communication Failure Alarms (Group 8)	176
A.10	Hardware Alarms (Group A)	177
A.11	Non-Cycle Overload Alarms (Group B)	178

A.1 Overload Alarms (Group 0)

This group includes all overload alarms that can occur during a weld cycle. This overload group will abort the weld cycle after stopping the sonics.

Table A.1 Overload Alarms (Group 0)

Alarm Code	Bit Assignment	Alarm	Description
001	Bit01	Weld Overload - Phase	This alarm is generated in case of weld phase is out of weld phase limit for weld phase limit time period.
002	Bit02	Weld Overload - Current	This alarm is generated in case of weld current reaches to peak RF current limit of the system.
003	Bit03	Weld Overload - Frequency	This alarm is generated in case of weld frequency is out of weld frequency low and high limit window.
004	Bit04	Weld Overload - Power	This alarm is generated in case of weld power reaches to peak RF power limit of the system.
005	Bit05	Weld Overload - Voltage	This alarm is generated in case of voltage during weld reaches to peak RF voltage limit of the system.
006	Bit06	Weld Overload - Temperature	This alarm is generated in case of temperature inside the system (at the heat sink) reaches to 85° C ($\pm 5^\circ$ C). NOTICE Alarm cannot be cleared until the temperature returns below threshold.
011	Bit17	Energy Brake Overload - Phase	This alarm is generated in case of phase is out of weld phase limit for weld phase limit time period during energy breaking.
012	Bit18	Energy Brake Overload - Current	This alarm is generated in case of weld current reaches to peak RF current limit of the system during energy breaking.
013	Bit19	Energy Brake Overload - Frequency	This alarm is generated in case of weld frequency is out of weld frequency low and high limit window during energy breaking.

Table A.1 Overload Alarms (Group 0)

Alarm Code	Bit Assignment	Alarm	Description
014	Bit20	Energy Brake Overload - Power	This alarm is generated in case of weld power reaches to peak RF power limit of the system during energy breaking.
015	Bit21	Energy Brake Overload - Voltage	This alarm is generated in case of voltage during weld reaches to peak RF voltage limit of the system during energy breaking.

A.2 Cutoff Alarms (Group 1)

This groups includes all cutoff alarms. Cutoff alarms are defined as a limit on a parameter, that when exceeded, will stop ultrasonics. The remaining portion of a weld cycle will continue.

Table A.2 Cutoff Alarms (Group 1)

Alarm Code	Bit Assignment	Alarm	Description
102	Bit02	Energy Cutoff	Energy cutoff alarm is generated if the energy value during sonics on exceeded to the set cutoff value during a weld.
103	Bit03	Power Cutoff	Power cutoff alarm is generated if the peak power value during sonics on exceeded to the set cutoff value.
104	Bit04	Custom Input1 Cutoff	User can configure one of the user analog input as a Custom Input1 and also set a cutoff value from that input. System will generate custom Input1 Cutoff alarm if the user input voltage exceeds from the cutoff value set by user.
105	Bit05	Time Cutoff (Maximum Time-out)	User can set a time cutoff for weld and the alarm will be generated if the sonic on time during weld exceeds to the set value.
106	Bit06	Frequency Low Cutoff	User can set frequency low cutoff (negative offset to be applied from weld start frequency) for weld and the alarm will be generated if the frequency during weld goes below to the weld start frequency minus set value.
107	Bit07	Frequency High Cutoff	User can set frequency high cutoff (positive offset to be applied from weld start frequency) for weld and the alarm will be generated if the frequency during weld goes above to the weld start frequency plus set value.
108	Bit08	Custom Input2 Cutoff	User can configure one of the user analog input as a Custom Input2 and also set a cutoff value from that input. System will generate Custom Input2 cutoff alarm if the user input voltage exceeds from the cutoff value set by user.

A.3 Setup Alarms (Group 2)

This group includes all alarms that can occur during setup.

Table A.3 Cycle Modified Alarms (Group 2)

Alarm Code	Bit Assignment	Alarm	Description
203	Bit02	Invalid Preset	Recalling invalid preset. Preset > 32.

A.4 Cycle Modified Alarms (Group 3)

Cycle modified alarms cause the cycle to be modified from the intended parameters. This can be caused by the user or equipment conditions changing. This group of alarms will always abort the cycle.

Table A.4 Cycle Modified Alarms (Group 3)

Alarm Code	Bit Assignment	Alarm	Description
301	Bit01	Trigger Lost During Weld Or Hold	This alarm is generated during a weld cycle in case actuator is present and trigger input is lost before completing the weld (in case of time, energy, peak power and ground detect mode).
302	Bit02	Cycle Aborted Via User I/O	This alarm is generated if user aborts the cycle using cycle abort user input.

A.5 Warning Alarms (Group 4)

Warnings occur when a condition is happening that may have been unexpected. This group of alarms does not abort the cycle. This group includes overloads during afterburst because they do not abort the cycle.

Table A.5 Warning Alarms (Group 4)

Alarm Code	Bit Assignment	Alarm	Description
404	Bit04	Amplitude Step Not Reached	This alarm is generated if Amplitude Stepping is ON but weld cycle finishes before stepping take places.
405	Bit05	Sonics Disabled Via User I/O	This alarm indicates the user has enabled an input pin as "Sonics Disable" and has run a cycle with this input active.
411	Bit17	Afterburst Overload - Phase	This alarm is generated in case of afterburst phase is out of Weld Phase limit for Weld Phase limit time period.
412	Bit18	Afterburst Overload - Current	This Alarm is generated in case of weld current reaches to peak RF current limit of the system during afterburst.
413	Bit19	Afterburst Overload - Frequency	This alarm is generated in case of Weld Frequency is out of Weld Frequency Low and High limit window during afterburst.
414	Bit20	Afterburst Overload - Power	This alarm is generated in case of weld power reaches to peak RF power limit of the system during afterburst.
415	Bit21	Afterburst Overload - Voltage	This alarm is generated in case of weld voltage reaches to peak RF voltage limit of the system during afterburst.
416	Bit22	Afterburst Overload - Temperature	The internal heat sink temperature is greater than allowed. NOTICE Alarm cannot be cleared until the temperature returns below threshold.

A.6 Limit Alarms (Group 5)

Limits will be reported at the end of the weld, but, unlike cutoffs, will not stop the sonics or abort the cycle.

Table A.6 Limit Alarms (Group 5)

Alarm Code	Bit Assignment	Alarm	Description
503	Bit03	Power - Minus Limit	This alarm is generated at the end of the cycle in case that Weld peak power is lower than the Power Minus limit.
504	Bit04	Power - Plus Limit	This alarm is generated at the end of the cycle in case that Weld peak power is bigger than the Power Plus limit.
505	Bit05	Time - Minus Limit	This alarm is generated at the end of the cycle in case that Weld time is lower than the Time Minus limit.
506	Bit06	Time - Plus Limit	This alarm is generated at the end of the cycle in case that Weld time is bigger than the time Plus limit.
507	Bit07	Energy - Minus Limit	This alarm is generated at the end of the cycle in case that Weld energy is lower than the energy Minus limit.
508	Bit08	Energy - Plus Limit	This alarm is generated at the end of the cycle in case that Weld energy is bigger than the energy Plus limit.

A.7 Equipment Failure Alarms (Group 6)

Equipment alarms are caused by user equipment malfunction. These alarms occur before a cycle starts and therefore, will prevent a cycle from starting until the malfunction is corrected.

NOTICE	
	Alarm message will not reset until the malfunction is corrected.

Table A.7 Equipment Failure Alarms (Group 6)

Alarm Code	Bit Assignment	Alarm	Description
601	Bit01	Start Input Still Active	This alarm is generated if External Start/Cycle Start/Trigger signal is active for more than 4 seconds after finishing the weld or while system is waiting to come into ready state.
602	Bit02	Trigger Active While ULS Active	This alarm is generated any time if Trigger and ULS both becomes active.
603	Bit03	Trigger Active In Ready	This alarm is generated if Trigger signal becomes active while system is in ready state and actuator is present.
604	Bit04	ULS Not Active In Ready	This alarm is generated if actuator is present and ULS is not active while system is already in ready state.
605	Bit05	Ground Detect Active In Ready	This alarm is generated if ground detect signal becomes active while system is in ready state.
607	Bit07	Cable Failure - User I/O	The cable detect user I/O feature has been enabled and detected that the assigned pin does not have the voltage applied.
608	Bit08	Field Bus Removed	Communication between the internal field bus card and the internal weld controller has failed.
609	Bit09	Start Input Lost	This alarm is generated when source of cycle start is removed before Trigger comes.

Table A.7 Equipment Failure Alarms (Group 6)

Alarm Code	Bit Assignment	Alarm	Description
610	Bit16	Cycle Abort In Ready	This alarm is generated if Cycle Abort signal becomes active while system is in ready state.
611	Bit17	ULS Time Out	This alarm is generated if Actuator is present and ULS does not become active with a time-out at the end of the cycle.
612	Bit18	ULS Active During Weld	This alarm is generated if System is waiting for TRS and ULS becomes active. After TRS is active and system jumps to next state of cycle this alarm is generated when ULS becomes active during cycle along with "TRS active while ULS Active" alarm.

A.8 No Cycle Alarms (Group 7)

No cycle alarms are caused by possible mechanical setup errors or user errors. These are usually time out errors because an expected input did not occur in time. They will prevent a cycle from continuing. So although a cycle may have started, the cycle will be aborted.

Table A.8 No Cycle Alarms (Group 7)

Alarm Code	Bit Assignment	Alarm	Description
701	Bit01	ULS Time-Out (Start Of Cycle)	A cycle start has been received but the upper limit switch has not gone inactive within the time-out specified by the system.
702	Bit02	Trigger Time-Out	A cycle has been started, but the trigger input has not gone active within the time-out specified by the system.
703	Bit03	External Sonics Delay Time-Out (User I/O)	The system is waiting for an external user defined input (if configured), but has not received the input within the time-out specified by the system.
704	Bit04	Interlock Not In Place (User I/O)	The system is waiting for a valid status from a user defined Interlock input (if configured), but the input is not active at the time of Cycle start.
705	Bit05	RF Switch Feedback Failure	A feedback signal from the RF switch not was not received within the time specified by the user.
706	Bit06	Part Not In Place (User I/O)	The system is waiting for an external user defined input, but the input is not active at the Cycle Start.
707	Bit07	Stack Number Not Valid For RF Switching	An invalid horn number is being requested from the preset. Any values outside the range of 16 horn numbers will cause an alarm.

A.9 Communication Failure Alarms (Group 8)

This group handles any communication issue that occur between processors. This is generally the result of noisy environments or other conditions that interrupt communications. Physical cable failures will be included in the Hardware Failure group. Because data cannot be transmitted between internal hardware, the cycle will be aborted.

NOTICE	
	Alarm message will not reset until the malfunction is corrected.

Table A.9 Communication Failure Alarms (Group 8)

Alarm Code	Bit Assignment	Alarm	Description
801	Bit01	Modbus Communication Failure	Internal communication failure.
802	Bit02	LCD Communication Failure	Communication between the LCD user interface and the internal weld controller has failed.
803	Bit03	Fieldbus Communication Failure	The field bus was detected at power on, but is no longer responding. Either the cable has been removed or the field bus master has stop working. If the system is powered down and field bus is not detected at power up, then the system can still be used without the field bus.

A.10 Hardware Alarms (Group A)

This group of alarms will deal with internal equipment failures. This will generally be equipment that is supplied by Branson as part in the internal workings of the power supply. Cycles cannot be started if there is a Hardware alarm. If a cycle is in process when the alarm is detected then the cycle is aborted.

NOTICE	
	Alarm message will not reset until the malfunction is corrected.

Table A.10 Hardware Alarms (Group A)

Alarm Code	Bit Assignment	Alarm	Description
A01	Bit01	LCD NOVRAM Failure	LCD NOVRAM is not working.
A02	Bit02	FRAM or NOVRAM Failure	FRAM or NOVRAM is not working.
A03	Bit03	SD RAM Failure	SD RAM is not working.
A04	Bit04	Connection Failure - WC to LCD	The physical connection between the WC board and LCD board is missing or broken.
A05	Bit05	Connection Failure - WC to DCP	The physical connection between the WC board and DCP board is missing or broken.
A06	Bit06	AC Line Voltage Lost	The AC line voltage to the system is lost but the 24 V supply is still present. After clearing the alarm, the system will run a Seek, Scan, or only power up, depending on the selected action in the Seek/Power Up Setup menu.
			ES bit activated, check ZSW1 Low Byte

A.11 Non-Cycle Overload Alarms (Group B)

This group deals with overloads that occur outside of a weld cycle. By definition a weld is not in process so the weld cycle counter is not affected and the weld is not aborted.

Table A.11 Non-Cycle Overload Alarms (Group B)

Alarm Code	Bit Assignment	Alarm	Description
b01	Bit01	Seek Overload - Phase	This alarm is generated in case of phase during Seek reaches to peak RF phase limit of the system.
b02	Bit02	Seek Overload - Current	This alarm is generated in case of current during Seek reaches to peak RF current limit of the system.
b03	Bit03	Seek Overload - Frequency	This alarm is generated in case of Frequency during seek is out of Seek Frequency Low and High limit window.
b04	Bit04	Seek Overload - Power	This alarm is generated in case of Power during seek reaches to peak RF Power limit of the system.
b05	Bit05	Seek Overload - Voltage	This alarm is generated in case of Voltage during seek reaches to peak RF voltage limit of the system.
b06	Bit06	Seek Overload - Temperature	<p>This alarm is generated in case of temperature inside the system (at the heat sink) reaches to 85° C (±5° C) during Seek.</p> <p>NOTICE Alarm cannot be cleared until the temperature returns below threshold.</p>
b11	Bit17	Test Overload - Phase	This alarm is generated in case of phase during Test reaches to peak RF phase limit of the system.
b12	Bit18	Test Overload - Current	This alarm is generated in case of current during Test reaches to peak RF current limit of the system.
b13	Bit19	Test Overload - Frequency	This alarm is generated in case of Frequency during seek is out of Test Frequency Low and High limit window.
b14	Bit20	Test Overload - Power	This alarm is generated in case of Power during Test reaches to peak RF Power limit of the system.
b15	Bit21	Test Overload - Voltage	This Alarm is generated in case of Voltage during Test reaches to peak RF voltage limit of the system.

Table A.11 Non-Cycle Overload Alarms (Group B)

Alarm Code	Bit Assignment	Alarm	Description
b16	Bit22	Test Overload - Temperature	<p>This alarm is generated in case of temperature inside the system (at the heat sink) reaches to 85° C ($\pm 5^{\circ}$ C) during Test.</p> <p>NOTICE Alarm cannot be cleared until the temperature returns below threshold.</p>



Appendix B: Communication Channel Commands

B.1	Weld Parameters	182
B.2	Seek Stack Parameters	186
B.3	Test Stack Parameters	187
B.4	Common Stack Parameters	188
B.5	Alarm Commands	189
B.6	Weld Parameter Status	190
B.7	Weld Status Commands	192
B.8	Seek Parameter Status	193
B.9	Seek Stack Commands	194
B.10	Test Parameter Status	195
B.11	Test Stack Commands	196
B.12	Scan Parameter Status	197
B.13	Scan Stack Commands	198
B.14	Process Data Channels	199
B.16	Token Access	201
B.17	Version, System, & RTC Information	202
B.18	System Configuration Parameters	203

B.1 Weld Parameters

Table B.1 Weld Parameters

PNU	Description	Data Type	AK	IND	PWE			Format	Unit
					Default	Min.	Max.		
1010	Preset Name (Character 1)	AIN T8	R: 4 W: 10	0..31/ 32	64	32	128	-	-
1011	Preset Name (Character 2)	AIN T8	R: 4 W: 10	0..31/ 32	64	32	128	-	-
1012	Preset Name (Character 3)	AIN T8	R: 4 W: 10	0..31/ 32	64	32	128	-	-
1013	Preset Name (Character 4)	AIN T8	R: 4 W: 10	0..31/ 32	64	32	128	-	-
1014	Preset Name (Character 5)	AIN T8	R: 4 W: 10	0..31/ 32	64	32	128	-	-
1015	Preset Name (Character 6)	AIN T8	R: 4 W: 10	0..31/ 32	64	32	128	-	-
1016	Preset Name (Character 7)	AIN T8	R: 4 W: 10	0..31/ 32	64	32	128	-	-
1017	Preset Name (Character 8)	AIN T8	R: 4 W: 10	0..31/ 32	64	32	128	-	-
1018	Preset Name (Character 9)	AIN T8	R: 4 W: 10	0..31/ 32	64	32	128	-	-
1019	Preset Name (Character 10)	AIN T8	R: 4 W: 10	0..31/ 32	64	32	128	-	-
1020	Preset Name (Character 11)	AIN T8	R: 4 W: 10	0..31/ 32	64	32	128	-	-
1021	Preset Name (Character 12)	AIN T8	R: 4 W: 10	0..31/ 32	64	32	128	-	-
1022	Preset Name (Character 13)	AIN T8	R: 4 W: 10	0..31/ 32	64	32	128	-	-
1023	Preset Name (Character 14)	AIN T8	R: 4 W: 10	0..31/ 32	64	32	128	-	-
1024	Preset Name (Character 15)	AIN T8	R: 4 W: 10	0..31/ 32	64	32	128	-	-
1025	Preset Name (Character 16)	AIN T8	R: 4 W: 10	0..31/ 32	64	32	128	-	-
1026	Preset Name (Character 17)	AIN T8	R: 4 W: 10	0..31/ 32	64	32	128	-	-
1027	Preset Name (Character 18)	AIN T8	R: 4 W: 10	0..31/ 32	64	32	128	-	-
1028	Preset Name (Character 19)	AIN T8	R: 4 W: 10	0..31/ 32	64	32	128	-	-

Table B.1 Weld Parameters

PNU	Description	Data Type	AK	IND	PWE			Format	Unit
					Default	Min.	Max.		
1029	Preset Name (Character 20)	AINT8	R: 4 W: 10	0..31/ 32	64	32	128	-	-
1040	Horn Number assigned to a preset	AUINT8	R: 1 W: 7	0..31/ 32	1	1	16	-	-
1060	Weld Mode (Function Mode) (0=Continuous, 1=Time, 2=Energy, 3=Peak Power, 4=Ground Detect>)	AINT32	R: 6 W: 12	0..31/ 32	0	0	4		
1061	Time	AINT32	R: 6 W: 12	0..31/ 32	10	10	30000		ms
1062	Energy (Value should be entered 10 times higher)	AINT32	R: 6 W: 12	0..31/ 32	10	1	99990		0.1xJ
1063	Peak Power	AINT32	R: 6 W: 12	0..31/ 32	1	1	100		%
1064	Ground Detect Time	AINT32	R: 6 W: 12	0..31/ 32	1	0	500		ms
1065	Amplitude 1	AINT32	R: 6 W: 12	0..31/ 32	100	10	100		%
1066	Amplitude 2	AINT32	R: 6 W: 12	0..31/ 32	100	10	100		%
1067	Amplitude Profile Criterion (0=Fix, 1=External analog in, 2=Step@Time, 3=Step@Energy, 4=Step@Power, 5=Step@External)	AINT32	R: 6 W: 12	0..31/ 32	0	0	5	Selection	-
1068	Amplitude Profile Time	AINT32	R: 6 W: 12	0..31/ 32	10	1	30000		ms
1069	Amplitude Profile Energy (Value should be entered 10 times higher)	AINT32	R: 6 W: 12	0..31/ 32	10	1	99990		0.1xJ
1070	Amplitude Profile Peak Power	AINT32	R: 6 W: 12	0..31/ 32	1	1	100		%
1071	Amplitude Start Ramp Time	AINT32	R: 6 W: 12	0..31/ 32	80	10	1000		ms
1072	Amplitude Profile Ramp Time	AINT32	R: 6 W: 12	0..31/ 32	80	10	1000		ms
1073	Frequency Resonance Store At End	AINT32	R: 6 W: 12	0..31/ 32	1	0	1	Selection	

Table B.1 Weld Parameters

PNU	Description	Data Type	AK	IND	PWE			Format	Unit
					Default	Min.	Max.		
1074	Frequency Offset (Relative)	AINT32	R: 6 W: 12	0..31/ 32	0	-500	500		Hz
1075	Hold Time	AINT32	R: 6 W: 12	0..31/ 32	10	10	30000	0=OFF	ms
1076	Energy Breaking	AINT32	R: 6 W: 12	0..31/ 32	1	0	1	Selection	
1077	EB Target Amplitude	AINT32	R: 6 W: 12	0..31/ 32	3	1	100		%
1078	EB Time	AINT32	R: 6 W: 12	0..31/ 32	20	10	1000		ms
1079	After Burst	AINT32	R: 6 W: 12	0..31/ 32	1	0	1	Selection	
1080	AB Amplitude	AINT32	R: 6 W: 12	0..31/ 32	100	10	100		%
1081	AB Time	AINT32	R: 6 W: 12	0..31/ 32	100	100	2000		ms
1082	AB Delay	AINT32	R: 6 W: 12	0..31/ 32	100	100	2000		ms
1083	Reserved								
1084	Scrub Amplitude	AINT32	R: 6 W: 12	0..31/ 32	100	10	100		%
1085	Reserved								
1086	Time Error High (Cutoff)	AINT32	R: 6 W: 12	0..31/ 32	6000	10	30000	0=OFF	ms
1087	Energy Error High (Cutoff) (Value should be entered 10 times higher)	AINT32	R: 6 W: 12	0..31/ 32	1	1	99990	0=OFF	0.1xJ
1088	Peak Power Error High (Cutoff)	AINT32	R: 6 W: 12	0..31/ 32	10	1	100	0=OFF	%
1089	- Time Limit	AINT32	R: 6 W: 12	0..31/ 32	10	10	30000	0=OFF	ms
1090	+ Time Limit	AINT32	R: 6 W: 12	0..31/ 32	30000	10	30000	0=OFF	ms
1091	- Energy Limit (Value should be entered 10 times higher)	AINT32	R: 6 W: 12	0..31/ 32	1	1	99990	0=OFF	0.1xJ
1092	+ Energy Limit (Value should be entered 10 times higher)	AINT32	R: 6 W: 12	0..31/ 32	99990	1	99990	0=OFF	0.1xJ
1093	- Peak Power Limit	AINT32	R: 6 W: 12	0..31/ 32	1	1	100	0=OFF	%

Table B.1 Weld Parameters

PNU	Description	Data Type	AK	IND	PWE			Format	Unit
					Default	Min.	Max.		
1094	+ Peak Power Limit	AINT32	R: 6 W: 12	0..31/ 32	100	1	100	0=OFF	%
1095	- Frequency Cutoff (Relative) (It depends on the power supply operating frequency)	AINT32	R: 6 W: 12	0..31/ 32	20 kHz: 500	20 kHz: 1	20 kHz: 500	0=OFF	Hz
					30 kHz: 750	30 kHz: 1	30 kHz: 750		
					40 kHz: 1000	40 kHz: 1	40 kHz: 1000		
1096	+ Frequency Cutoff (Relative) (It depends on the power supply operating frequency)	AINT32	R: 6 W: 12	0..31/ 32	20 kHz: 500	20 kHz: 1	20 kHz: 500	0=OFF	Hz
					30 kHz: 750	30 kHz: 1	30 kHz: 750		
					40 kHz: 1000	40 kHz: 1	40 kHz: 1000		
1097	Ground Detect Error	AINT32	R: 6 W: 12	0..31/ 32	0	0	1	Selection	

B.2 Seek Stack Parameters

Table B.2 Seek Stack Parameters

PNU	Description	Data Type	AK	IND	PWE			Format	Unit
					Default	Min.	Max.		
1460	Time	AINT32	R: 6 W: 12	0..15 / 16	500	10	1000		ms
1462	Amplitude Start Ramp Time	AINT32	R: 6 W: 12	0..15 / 16	80	10	1000		ms
1465	Frequency Offset (Relative)	AINT32	R: 6 W: 12	0..15 / 16	0	-500	500		Hz

B.3 Test Stack Parameters

Table B.3 Test Stack Parameters

PNU	Description	Data Type	AK	IND	PWE			Format	Unit
					Default	Min.	Max.		
1475	Test Amplitude	AINT32	R: 6 W: 12	0..15 / 16	100	10	100	-	%

B.4 Common Stack Parameters

Table B.4 Common Stack Parameters

PNU	Description	Data Type	AK	IND	PWE			Format	Unit
					Default	Min.	Max.		
1505	Digital Tune Frequency	AINT32	R: 6 W: 12	0..15 / 16	20 kHz: 19,950	20 kHz: 19,450	20 kHz: 20,450	-	Hz
					30 kHz: 30,000	30 kHz: 29,250	30 kHz: 30,750	-	Hz
					40 kHz: 39,900	40 kHz: 38,900	40 kHz: 40,900	-	Hz

B.5 Alarm Commands

Table B.5 Alarm Commands

PNU	Description	Data Type	AK	IND	Format
200	OL - Overload Group 0 (bit 0-31)	UINT32	R: 6	0	OEPB
204	CU - Cutoffs Group 1 (bit 0-31)	UINT32	R: 6	0	OEPB
208	SE - Setup Group 2 (bit 0-31)	UINT32	R: 6	0	OEPB
212	CM - Cycle Modified Group 3 (bit 0-31)	UINT32	R: 6	0	OEPB
216	WA - Warnings Group 4 (bit 0-31)	UINT32	R: 6	0	OEPB
220	LM - Limits Group 5 (bit 0-31)	UINT32	R: 6	0	OEPB
224	EQ - Equip.Failure Group 6 (bit 0-31)	UINT32	R: 6	0	OEPB
228	NC - No Cycle Group 7 (bit 0-31)	UINT32	R: 6	0	OEPB
232	CF - Comm. Failure Group 8 (bit 0-31)	UINT32	R: 6	0	OEPB
240	HW - Hardware Group A (bit 0-31)	UINT32	R: 6	0	OEPB
244	NO - No Cycle Overload Group B (bit 0-31)	UINT32	R: 6	0	OEPB

B.6 Weld Parameter Status

Table B.6 Weld Parameter Status

PNU	Description	Data Type	AK	IND	Format
1210	Preset Name (Character 1)	AINT8	R: 4	0..31/32	OEPB
1211	Preset Name (Character 2)	AINT8	R: 4	0..31/32	OEPB
1212	Preset Name (Character 3)	AINT8	R: 4	0..31/32	OEPB
1213	Preset Name (Character 4)	AINT8	R: 4	0..31/32	OEPB
1214	Preset Name (Character 5)	AINT8	R: 4	0..31/32	OEPB
1215	Preset Name (Character 6)	AINT8	R: 4	0..31/32	OEPB
1216	Preset Name (Character 7)	AINT8	R: 4	0..31/32	OEPB
1217	Preset Name (Character 8)	AINT8	R: 4	0..31/32	OEPB
1218	Preset Name (Character 9)	AINT8	R: 4	0..31/32	OEPB
1219	Preset Name (Character 10)	AINT8	R: 4	0..31/32	OEPB
1220	Preset Name (Character 11)	AINT8	R: 4	0..31/32	OEPB
1221	Preset Name (Character 12)	AINT8	R: 4	0..31/32	OEPB
1222	Preset Name (Character 13)	AINT8	R: 4	0..31/32	OEPB
1223	Preset Name (Character 14)	AINT8	R: 4	0..31/32	OEPB
1224	Preset Name (Character 15)	AINT8	R: 4	0..31/32	OEPB
1225	Preset Name (Character 16)	AINT8	R: 4	0..31/32	OEPB
1226	Preset Name (Character 17)	AINT8	R: 4	0..31/32	OEPB
1227	Preset Name (Character 18)	AINT8	R: 4	0..31/32	OEPB
1228	Preset Name (Character 19)	AINT8	R: 4	0..31/32	OEPB
1229	Preset Name (Character 20)	AINT8	R: 4	0..31/32	OEPB
1306*	RTC, Date (DD/MM/YY)	AUINT32	R: 6	0..31/32	OEPB
1307**	RTC, Time (SS:MM:HH)	AUINT32	R: 6	0..31/32	OEPB
1308***	Ctm. Fct. Cycle Counter	AUINT32	R: 6	0..31/32	OEPB
1309	OL - Overload Group 0 (bit 0-31)	AUINT32	R: 6	0..31/32	OEPB
1313	CU - Cutoffs Group 1 (bit 0-31)	AUINT32	R: 6	0..31/32	OEPB
1317	SE - Setup Group 2 (bit 0-31)	AUINT32	R: 6	0..31/32	OEPB
1321	CM - Cycle Modified Group 3 (bit 0-31)	AUINT32	R: 6	0..31/32	OEPB
1325	WA - Warnings Group 4 (bit 0-31)	AUINT32	R: 6	0..31/32	OEPB

Table B.6 Weld Parameter Status

PNU	Description	Data Type	AK	IND	Format
1329	LM - Limits Group 5 (bit 0-31)	AUINT32	R: 6	0..31/32	OEFB
1333	EQ - Equipment Failure Group 6 (bit 0-31)	AUINT32	R: 6	0..31/32	OEPB
1337	NC - No Cycle Group 7 (bit 0-31)	AUINT32	R: 6	0..31/32	OEPB
1341	CF - Comm. Failure Group 8 (bit 0-31)	AUINT32	R: 6	0..31/32	OEPB
1349	HW - Hardware Group A (bit 0-31)	AUINT32	R: 6	0..31/32	OEPB
1353	NO - No Cycle Overload Group B (bit 0-31)	AUINT32	R: 6	0..31/32	OEPB
1357	Error Reason	AUINT32	R: 6	0..31/32	OEPB

*(Date) It's given in the order: day, month, year - for example 180810

18 Hex = 24 decimal = day

08 Hex = 08 decimal = month

10 Hex = 16 decimal = year

Date = 24/08/16

** (Time) It's given in the order: seconds, minutes, hours - for example 371E0F

37 Hex = 55 decimal = seconds

1E Hex = 30 decimal = minutes

0F Hex = 15 decimal = hours

Time = 15:30:55

***ID 1308 is a 32-bit long command

B.7 Weld Status Commands

Table B.7 Weld Status Commands

PNU	Description	Data Type	AK	IND	Format	Unit	Other
1360	Weld Time	AINT32	R: 6	0..31 / 32		ms	1), 2)
1361	Hold Time	AINT32	R: 6	0..31 / 32		ms	1), 2)
1362	Energy	AINT32	R: 6	0..31 / 32		0.1 J	1), 2)
1363	Peak Power	AINT32	R: 6	0..31 / 32		%	1), 2)
1364	Average Power	AINT32	R: 6	0..31 / 32		%	1), 2)
1365	Average Amplitude A	AINT32	R: 6	0..31 / 32		%	1), 2)
1366	Average Amplitude B	AINT32	R: 6	0..31 / 32		%	1), 2)
1367	Recalled Res.- Frequency (Abs.)	AINT32	R: 6	0..31 / 32		Hz	1), 2)
1368	Start Frequency (Abs.)	AINT32	R: 6	0..31 / 32		Hz	1), 2)
1369	End Frequency (Abs.)	AINT32	R: 6	0..31 / 32		Hz	1), 2)
1370	Stored Frequency (Abs.)	AINT32	R: 6	0..31 / 32		Hz	1), 2)
1371	Res.-Frequency OK	AINT32	R: 6	0..31 / 32	Selection		1), 2)
1372	End Amplitude Set	AINT32	R: 6	0..31 / 32		%	1), 2)
1373	End Amplitude	AINT32	R: 6	0..31 / 32		%	1), 2)
1374	End Psv	AINT32	R: 6	0..31 / 32		%	1), 2)
1375	End Power	AINT32	R: 6	0..31 / 32		%	1), 2)
1376	End Current	AINT32	R: 6	0..31 / 32		%	1), 2)
1377	End Phase	AINT32	R: 6	0..31 / 32		deg. (°)	1), 2)
1378	End Temperature	AINT32	R: 6	0..31 / 32		°C	1), 2)

B.8 Seek Parameter Status

Table B.8 Seek Parameter Status

PNU	Description	Data Type	AK	IND	Format
1625*	RTC, Date (DD/MM/YY)	AUINT32	R: 6	0..15/16	OEPB
1626**	RTC, Time (SS:MM:HH)	AUINT32	R: 6	0..31/32	OEPB
1630	OL - Overload Group 0 (bit 0-31)	AUINT32	R: 6	0..31/32	OEPB
1634	CU - Cutoffs Group 1 (bit 0-31)	AUINT32	R: 6	0..31/32	OEPB
1638	SE - Setup Group 2 (bit 0-31)	AUINT32	R: 6	0..31/32	OEPB
1642	CM - Cycle Modified Group 3 (bit 0-31)	AUINT32	R: 6	0..31/32	OEPB
1646	WA - Warnings Group 4 (bit 0-31)	AUINT32	R: 6	0..31/32	OEPB
1650	LM - Limits Group 5 (bit 0-31)	AUINT32	R: 6	0..31/32	OEFB
1654	EQ - Equipment Failure Group 6 (bit 0-31)	AUINT32	R: 6	0..31/32	OEPB
1658	NC - No Cycle Group 7 (bit 0-31)	AUINT32	R: 6	0..31/32	OEPB
1662	CF - Comm. Failure Group 8 (bit 0-31)	AUINT32	R: 6	0..31/32	OEPB
1670	HW - Hardware Group A (bit 0-31)	AUINT32	R: 6	0..31/32	OEPB
1674	NO - No Cycle Overload Group B (bit 0-31)	AUINT32	R: 6	0..31/32	OEPB
1678	Error Reason	AUINT32	R: 6	0..31/32	-

*(Date) It's given in the order: day, month, year - for example 180810

18 Hex = 24 decimal = day

08 Hex = 08 decimal = month

10 Hex = 16 decimal = year

Date = 24/08/16

** (Time) It's given in the order: seconds, minutes, hours - for example 371E0F

37 Hex = 55 decimal = seconds

1E Hex = 30 decimal = minutes

0F Hex = 15 decimal = hours

Time = 15:30:55

B.9 Seek Stack Commands

Table B.9 Seek Stack Commands

PNU	Description	Data Type	AK	IND	Format	Unit	Other
1680	Time	AINT32	R: 6	0..15 / 16	-	ms	1)
1681	Average Amplitude	AINT32	R: 6	0..15 / 16	-	%	1)
1682	Recalled Res.- Frequency (Abs.)	AINT32	R: 6	0..15 / 16	-	Hz	1)
1683	Start Frequency (Abs.)	AINT32	R: 6	0..15 / 16	-	Hz	1)
1684	End Frequency (Abs.)	AINT32	R: 6	0..15 / 16	-	Hz	1)
1685	Stored Frequency (Abs.)	AINT32	R: 6	0..15 / 16	-	Hz	1)
1686	Res.-Frequency OK	AINT32	R: 6	0..15 / 16	Selection		1)
1687	End Amplitude Set	AINT32	R: 6	0..15 / 16	-	%	1)
1688	End Amplitude	AINT32	R: 6	0..15 / 16	-	%	1)
1689	End Psv	AINT32	R: 6	0..15 / 16	-	%	1)
1690	End Power	AINT32	R: 6	0..15 / 16	-	%	1)
1691	End Current	AINT32	R: 6	0..15 / 16	-	%	1)
1692	End Phase	AINT32	R: 6	0..15 / 16	-	deg. (°)	1)
1693	End Temperature	AINT32	R: 6	0..15 / 16	-	°C	1)

B.10 Test Parameter Status

Table B.10 Test Parameter Status

PNU	Description	Data Type	AK	IND	Format
1725	RTC, Date	AUINT32	R: 6	0..15/16	OEPB
1726	RTC, Time	AUINT32	R: 6	0..31/32	OEPB
1730	OL - Overload Group 0 (bit 0-31)	AUINT32	R: 6	0..31/32	OEPB
1734	CU - Cutoffs Group 1 (bit 0-31)	AUINT32	R: 6	0..31/32	OEPB
1738	SE - Setup Group 2 (bit 0-31)	AUINT32	R: 6	0..31/32	OEPB
1742	CM - Cycle Modified Group 3 (bit 0-31)	AUINT32	R: 6	0..31/32	OEPB
1746	WA - Warnings Group 4 (bit 0-31)	AUINT32	R: 6	0..31/32	OEPB
1750	LM - Limits Group 5 (bit 0-31)	AUINT32	R: 6	0..31/32	OEFB
1754	EQ - Equipment Failure Group 6 (bit 0-31)	AUINT32	R: 6	0..31/32	OEPB
1758	NC - No Cycle Group 7 (bit 0-31)	AUINT32	R: 6	0..31/32	OEPB
1762	CF - Comm. Failure Group 8 (bit 0-31)	AUINT32	R: 6	0..31/32	OEPB
1770	HW - Hardware Group A (bit 0-31)	AUINT32	R: 6	0..31/32	OEPB
1774	NO - No Cycle Overload Group B (bit 0-31)	AUINT32	R: 6	0..31/32	OEPB
1778	Error Reason	AUINT32	R: 6	0..31/32	-

B.11 Test Stack Commands

Table B.11 Test Stack Commands

PNU	Description	Data Type	AK	IND	Format	Unit	Other
1780	Time	AINT32	R: 6	0..15 / 16	-	ms	1)
1781	Average Amplitude A	AINT32	R: 6	0..15 / 16	-	%	1)
1782	Average Amplitude B	AINT32	R: 6	0..15 / 16	-	%	1)
1783	Recalled Res.- Frequency (Abs.)	AINT32	R: 6	0..15 / 16	-	Hz	1)
1784	Res.-Frequency OK	AINT32	R: 6	0..15 / 16	Selection	-	-
1785	Start Frequency (Abs.)	AINT32	R: 6	0..15 / 16	-	Hz	1)
1786	End Frequency (Abs.)	AINT32	R: 6	0..15 / 16	-	Hz	1)
1787	End Amplitude Set	AINT32	R: 6	0..15 / 16	-	%	1)
1788	End Amplitude	AINT32	R: 6	0..15 / 16	-	%	1)
1789	End Psv	AINT32	R: 6	0..15 / 16	-	%	1)
1790	End Power	AINT32	R: 6	0..15 / 16	-	%	1)
1791	End Current	AINT32	R: 6	0..15 / 16	-	%	1)
1792	End Phase	AINT32	R: 6	0..15 / 16	-	deg. (°)	1)
1793	End Temperature	AINT32	R: 6	0..15 / 16	-	°C	1)

B.12 Scan Parameter Status

Table B.12 Scan Parameter Status

PNU	Description	Data Type	AK	IND	Format
1825	RTC, Date	AUINT32	R: 6	0..15/16	OEPB
1826	RTC, Time	AUINT32	R: 6	0..31/32	OEPB
1830	OL - Overload Group 0 (bit 0-31)	AUINT32	R: 6	0..31/32	OEPB
1834	CU - Cutoffs Group 1 (bit 0-31)	AUINT32	R: 6	0..31/32	OEPB
1838	SE - Setup Group 2 (bit 0-31)	AUINT32	R: 6	0..31/32	OEPB
1842	CM - Cycle Modified Group 3 (bit 0-31)	AUINT32	R: 6	0..31/32	OEPB
1846	WA - Warnings Group 4 (bit 0-31)	AUINT32	R: 6	0..31/32	OEPB
1850	LM - Limits Group 5 (bit 0-31)	AUINT32	R: 6	0..31/32	OEFB
1854	EQ - Equipment Failure Group 6 (bit 0-31)	AUINT32	R: 6	0..31/32	OEPB
1858	NC - No Cycle Group 7 (bit 0-31)	AUINT32	R: 6	0..31/32	OEPB
1862	CF - Comm. Failure Group 8 (bit 0-31)	AUINT32	R: 6	0..31/32	OEPB
1870	HW - Hardware Group A (bit 0-31)	AUINT32	R: 6	0..31/32	OEPB
1874	NO - No Cycle Overload Group B (bit 0-31)	AUINT32	R: 6	0..31/32	OEPB
1878	Error Reason	AUINT32	R: 6	0..31/32	-

B.13 Scan Stack Commands

Table B.13 Scan Stack Commands

PNU	Description	Data Type	AK	IND	Format	Unit	Other
1880	Time	AINT32	R: 6	0..15 / 16	-	ms	1)
1881	Start Frequency (Abs.)	AINT32	R: 6	0..15 / 16	-	Hz	1)
1882	End Frequency (Abs.)	AINT32	R: 6	0..15 / 16	-	Hz	1)
1883	End Amplitude	AINT32	R: 6	0..15 / 16	-	%	1)
1884	End Psv	AINT32	R: 6	0..15 / 16	-	%	1)
1885	End Power	AINT32	R: 6	0..15 / 16	-	%	1)
1886	End Current	AINT32	R: 6	0..15 / 16	-	%	1)
1887	End Phase	AINT32	R: 6	0..15 / 16	-	deg. (°)	1)
1888	End Temperature	AINT32	R: 6	0..15 / 16	-	°C	1)

B.14 Process Data Channels

Table B.14 Process Data Channels

Selection	Description	Data Type	Format	Unit
-	SELZSVx	-	-	-
1	Amplitude-Set	INT16	-	%
20	Amplitude	INT16	-	%
21	Current	INT16	-	%
22	Power	INT16	-	%
23	Phase	INT16	-	deg. (°)
26	Psv	INT16	-	%
27	Frequency	UINT16	-	Hz
28	Temperature	INT16	-	°C
-	SELSTVx	-	-	-
1	Ext. Amplitude-Set	INT16	-	%
Sel.-Ack.	-	-	-	-
-	SELAZSV / SELASTV	-	-	-
0xFF	Error, Undefined Selection	-	-	-

B.15 Communication Channel

Table B.15 Communication Channel

Number	Description	Data Type	Index	Access	Unit
400	Amplitude - Set	INT16	0	R	%
420	Amplitude	INT16	0	R	%
421	Current	INT16	0	R	%
422	Power	INT16	0	R	%
423	Phase	INT16	0	R	deg
426	Psv	INT16	0	R	%
427	Frequency	INT16	0	R	Hz
428	Temperature	INT16	0	R	degC
440	Ext. Amplitude-Set	INT16	0	R	%

B.16 Token Access

Table B.16 Token Access

PNU	Description	Data Type	AK	IND
50	Get Access Token	UINT8	R: 1	0
51	Put Access Token (Read always 0)	UINT8	R: 1	0
51	Put Access Token	UINT8	W: 7	0

B.17 Version, System, & RTC Information

Table B.17 Version, System, & RTC Information

PNU	Description	Data Type	AK	IND	Format
100	DCP, HW - Version	UINT32	R: 6	0	x.xx
101	DCP, FPGA - Version	UINT32	R: 6	0	x.xx
102	DCP, Bootloader - Version	UINT32	R: 6	0	x.xx
103	DCP, Firmware - Version	UINT32	R: 6	0	x.xx
110	WC, HW - Version	UINT32	R: 6	0	x.xx
112	WC, Bootloader - Version	UINT32	R: 6	0	x.xx
113	WC, Firmware - Version	UINT32	R: 6	0	x.xx
150	PS Frequency	UINT16	R: 5	0	Hz
151	PS Wattage	UINT16	R: 5	0	Watts
154	PS Serial Number	AINT8	R: 1	0..19	-
170*	RTC, Date (DD/MM/YY)	UINT32	R: 6 W: 12	0	-
171**	RTC, Time (SS:MM:HH)	UINT32	R: 6 W: 12	0	-

*(Date) It's given in the order: day, month, year - for example 180810

18 Hex = 24 decimal = day

08 Hex = 08 decimal = month

10 Hex = 16 decimal = year

Date = 24/08/16

** (Time) It's given in the order: seconds, minutes, hours - for example 371E0F

37 Hex = 55 decimal = seconds

1E Hex = 30 decimal = minutes

0F Hex = 15 decimal = hours

Time = 15:30:55

B.18 System Configuration Parameters

Table B.18 System Configuration Parameters

PNU	Description	Data Type	AK	IND	Format
950	Clear Memory Before Seek	UINT8	R: 1 W: 7	0	-
951	Clear Memory with Reset	UINT8	R: 1 W: 7	0	-
952	Set Digital Tine with Horn Scan	UINT8	R: 1 W: 7	0	-
953	Clear Memory at Power Up	UINT8	R: 1 W: 7	0	-



Appendix C: Timing Diagrams

C.1 **Timing Diagrams** 206

C.1 Timing Diagrams

C.1.1 RF Switching Direct With Feedback, With And Without Alarm

Figure C.1 RF Switching Direct With Feedback, With And Without Alarm

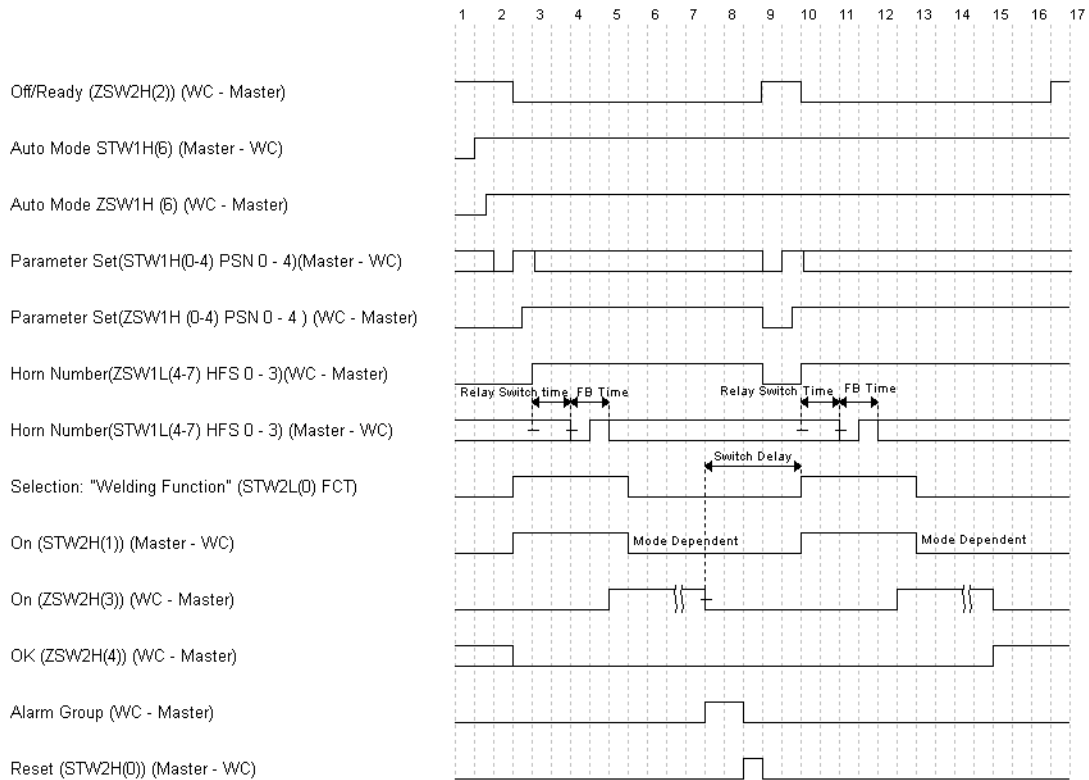

C.1.2 RF Switching I/O Direct With Feedback, With And Without Alarm

Figure C.2 RF Switching I/O Direct With Feedback, With And Without Alarm

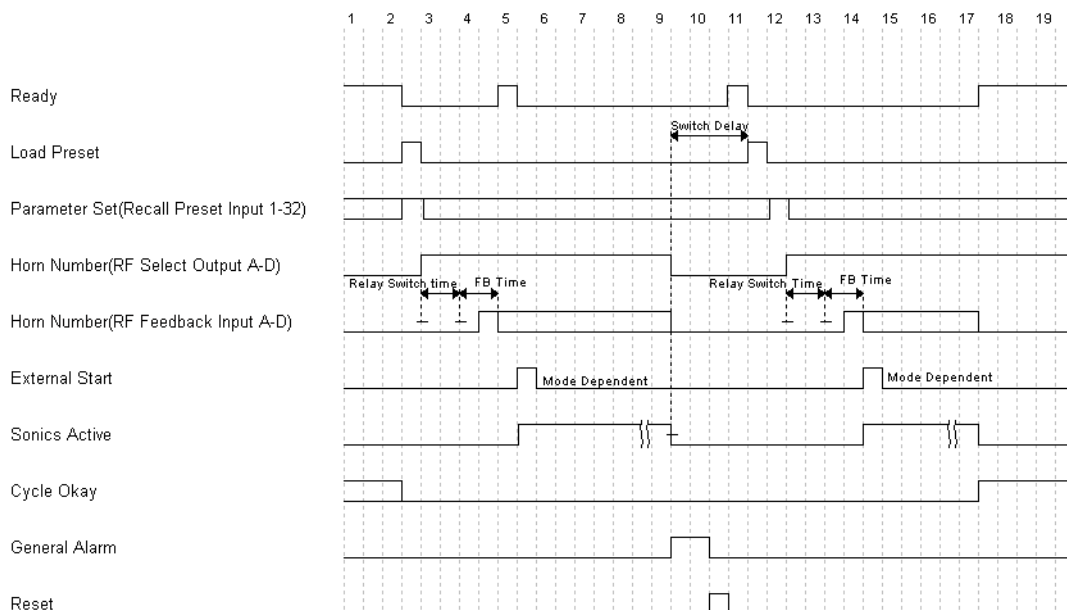

C.1.3 RF Switching I/O Direct With Feedback, With And Without Alarm, And Load On Start

Figure C.3 RF Switching I/O Direct With Feedback, With And Without Alarm, And Load On Start

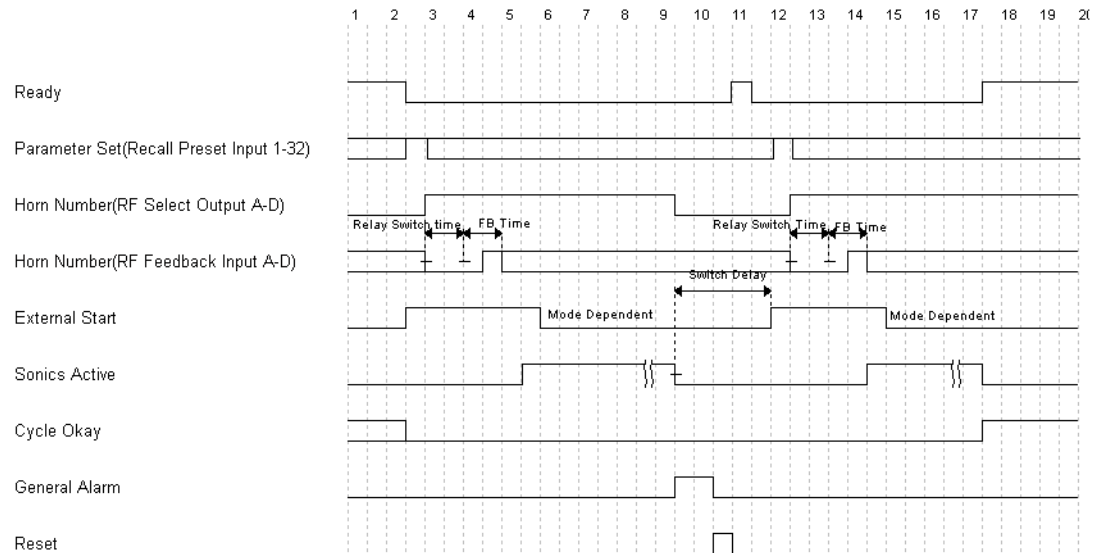

C.1.4 RF Switching I/O With Off, With And Without Alarm, And Load On Start

Figure C.4 RF Switching I/O With Off, With And Without Alarm, And Load On Start

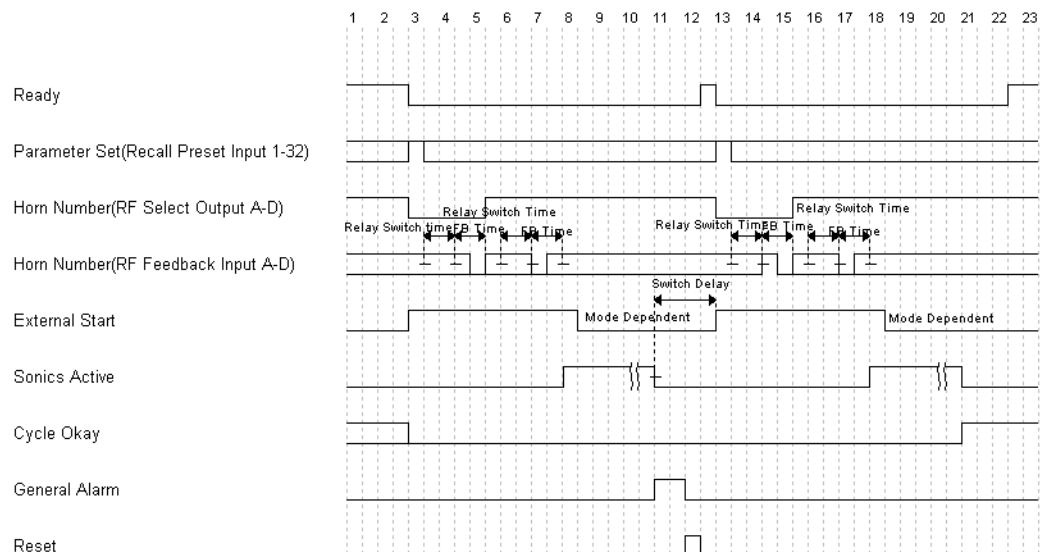

C.1.5 RF Switching I/O With Off, With Feedback, With And Without Alarm

Figure C.5 RF Switching I/O With Off, With Feedback, With And Without Alarm

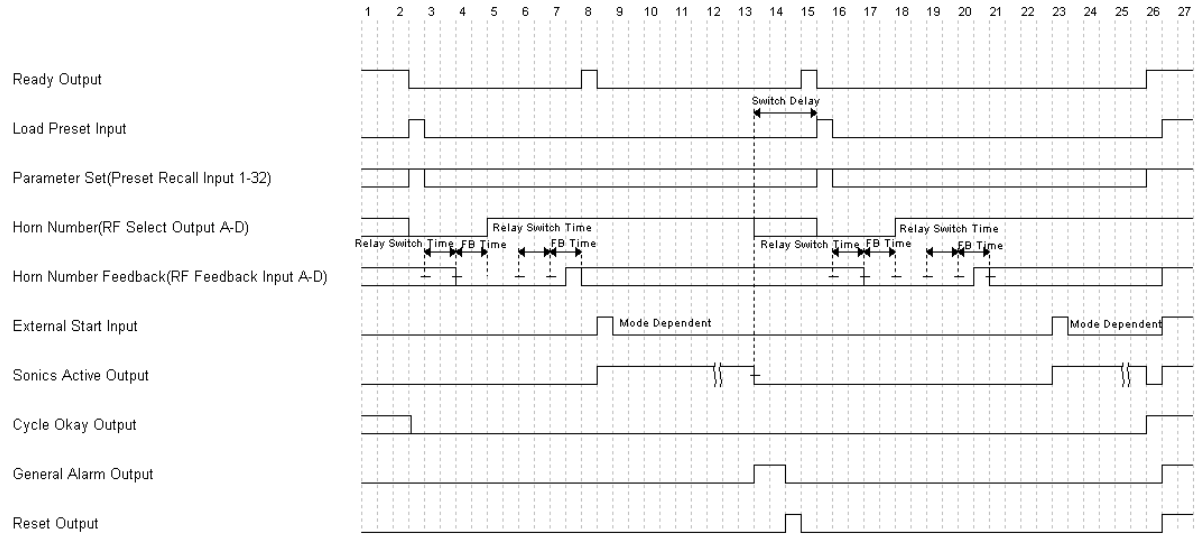

C.1.6 RF Switching With Off, With Feedback, With And Without Alarm

Figure C.6 RF Switching With Off, With Feedback, With And Without Alarm

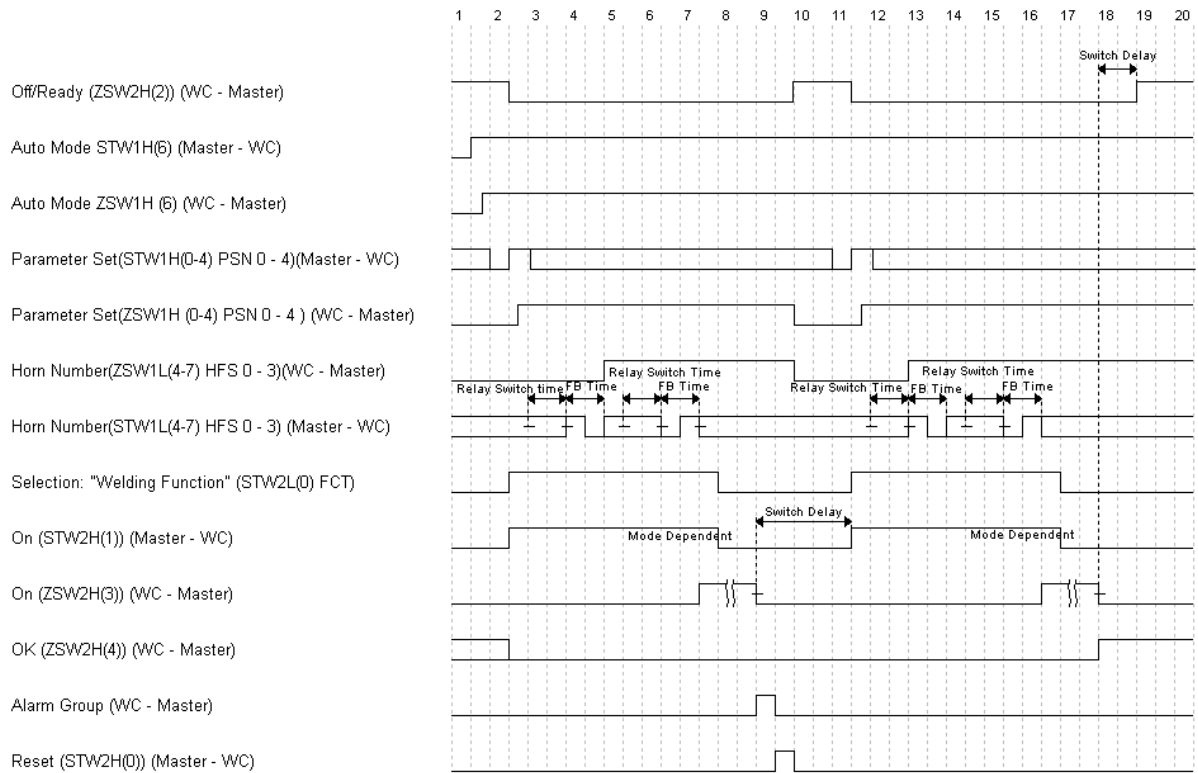

C.1.7 Timing Diagram For All Other Modes With Actuator

Figure C.7 Timing Diagram For All Other Modes With Actuator

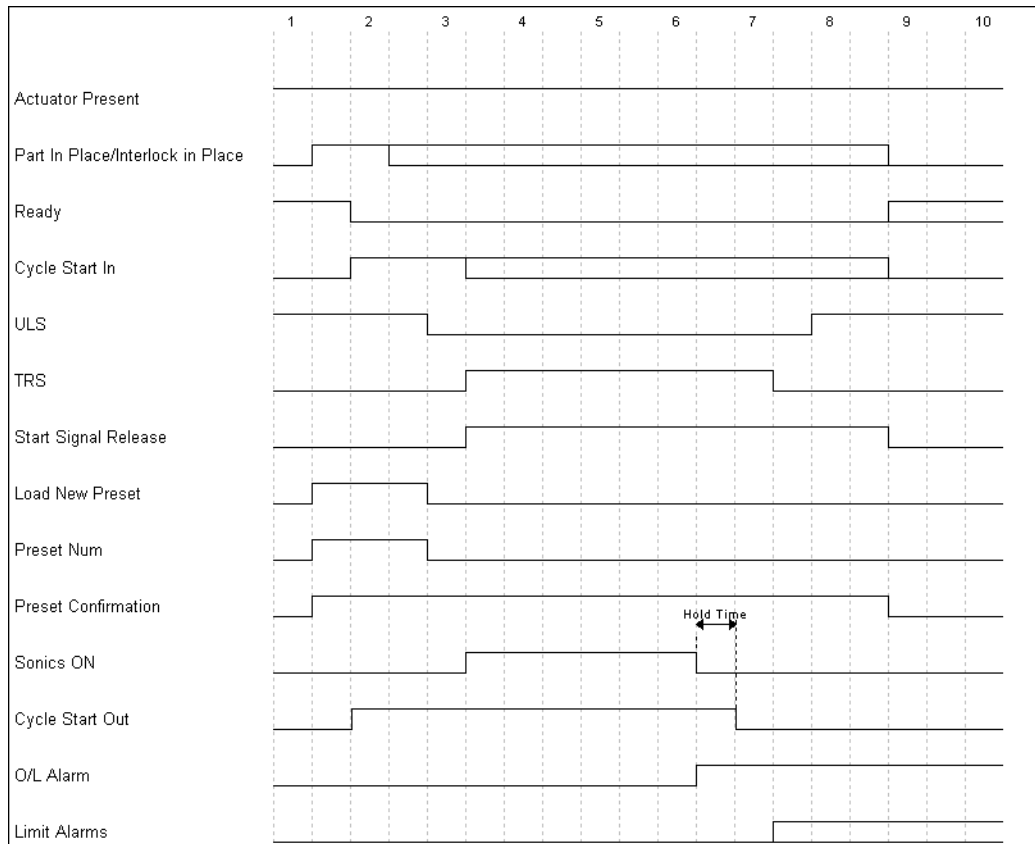

C.1.8 Timing Diagram For Cycle Abort With Actuator

Figure C.8 Timing Diagram For Cycle Abort With Actuator

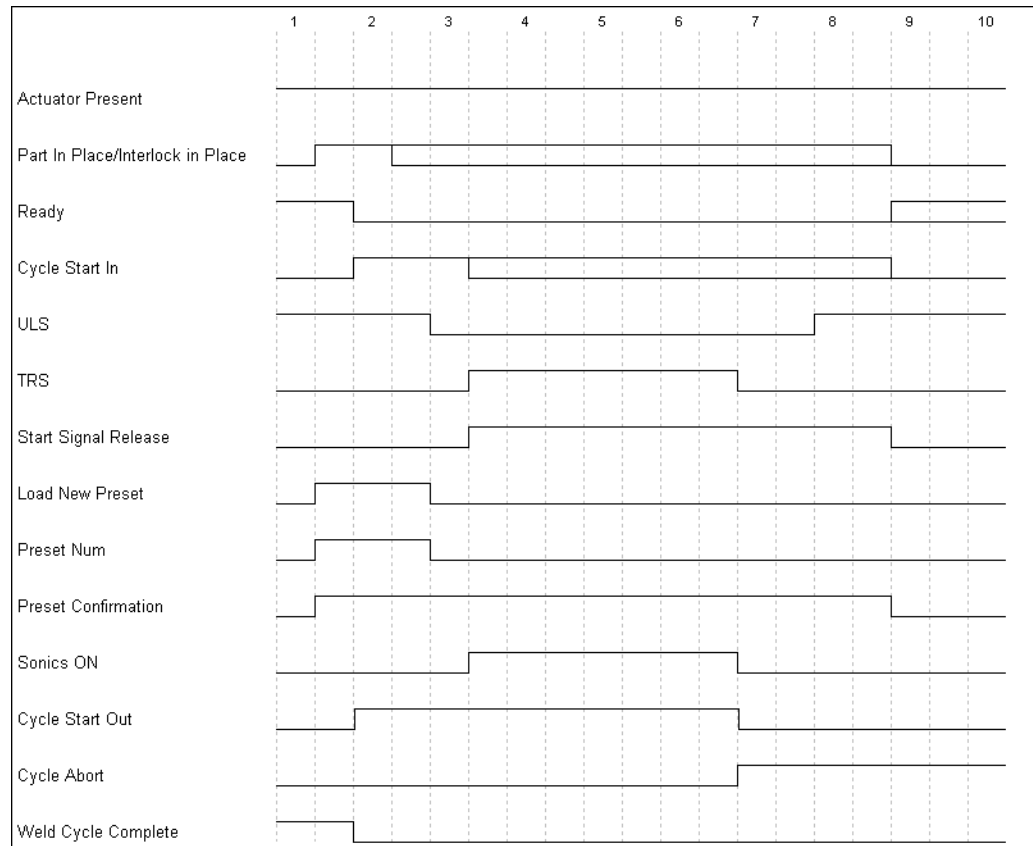

C.1.9 Timing Diagram For Ground Detect With Actuator

Figure C.9 Timing Diagram For Ground Detect With Actuator

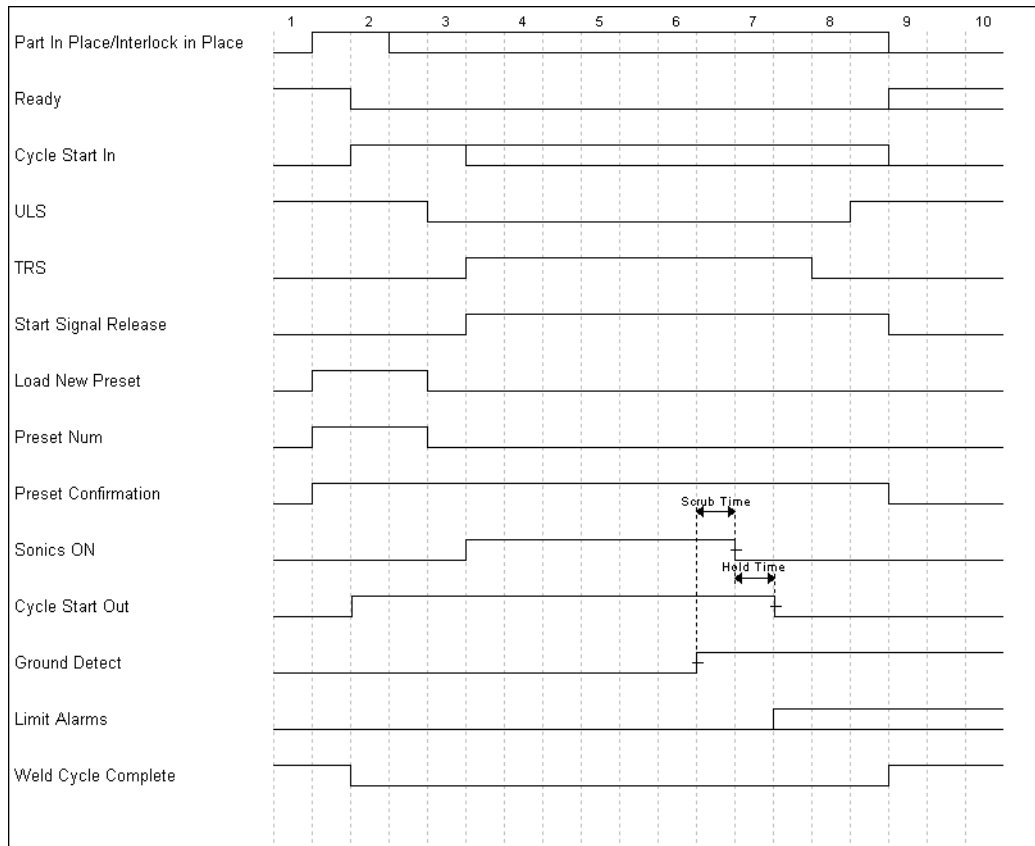

Appendix D: Signal Diagrams

D.1 Signal Diagrams 214

D.1 Signal Diagrams

Figure D.1 Continuous Mode

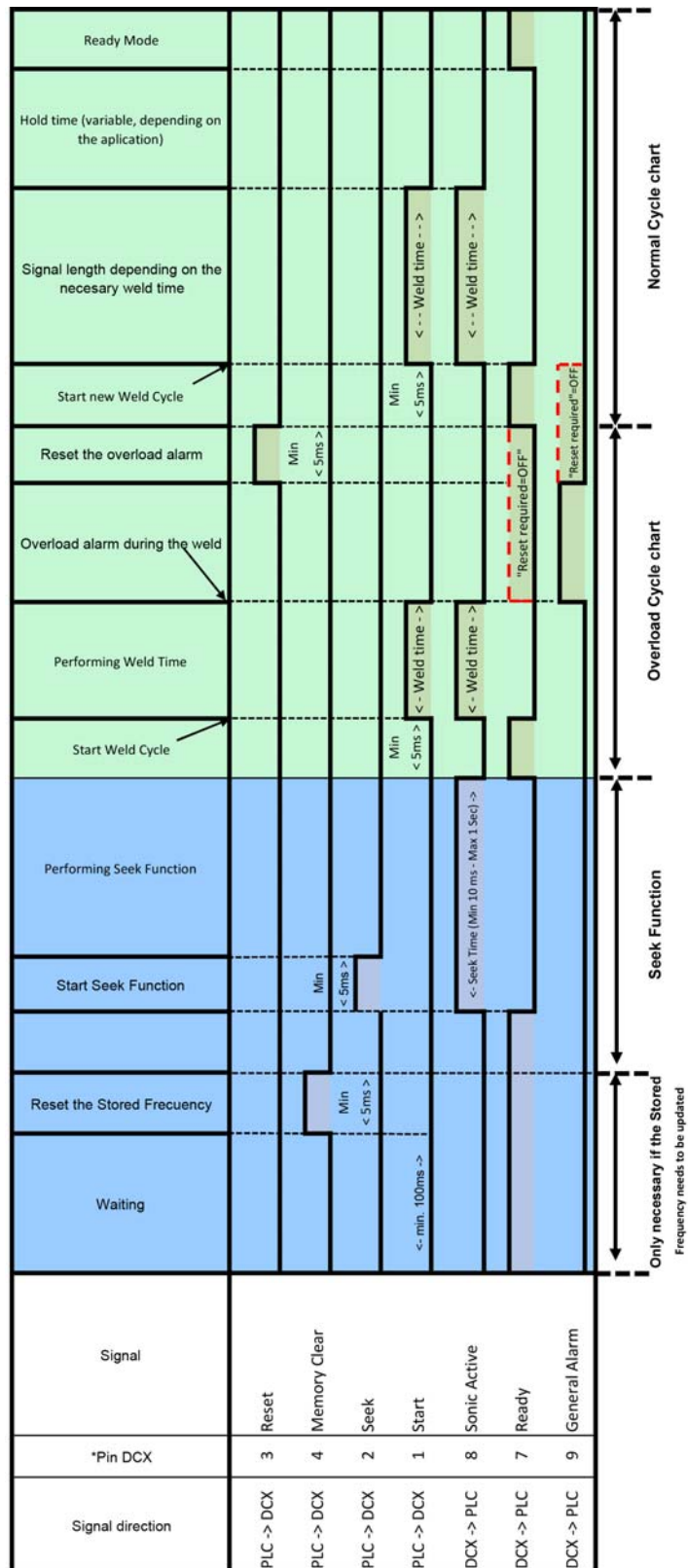

*Inputs/Outputs are configurable on the User I/O Configuration web page
 ---If Reset Required is unchecked for Overload in Alarm Webpage interface, Ready signal will be enabled after Start switch is released

Figure D.2 Time Mode

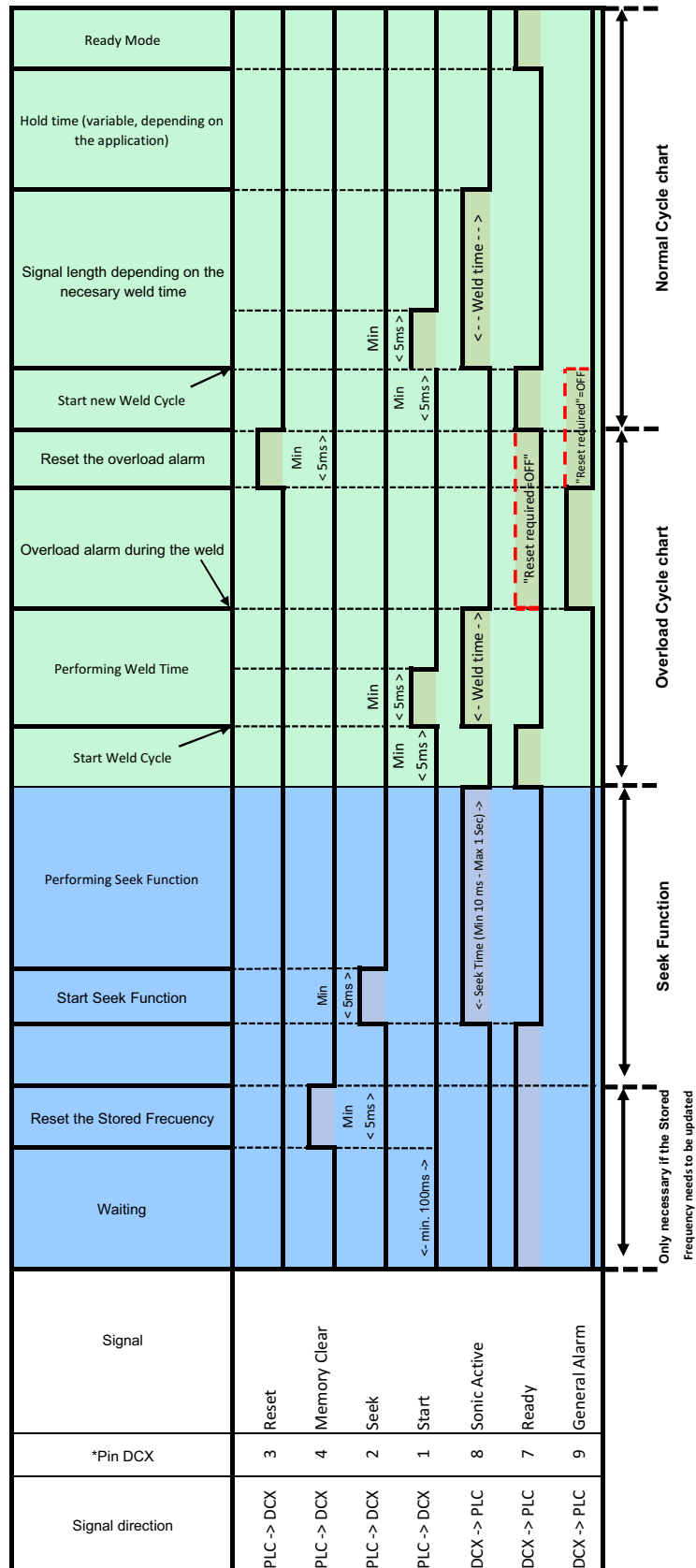

*Inputs/Outputs are configurable on the User I/O Configuration web page

--- If Reset Required is unchecked for Overload in Alarm Webpage interface, Ready signal will be enabled when General Alarm becomes active

Figure D.3 AE Actuator

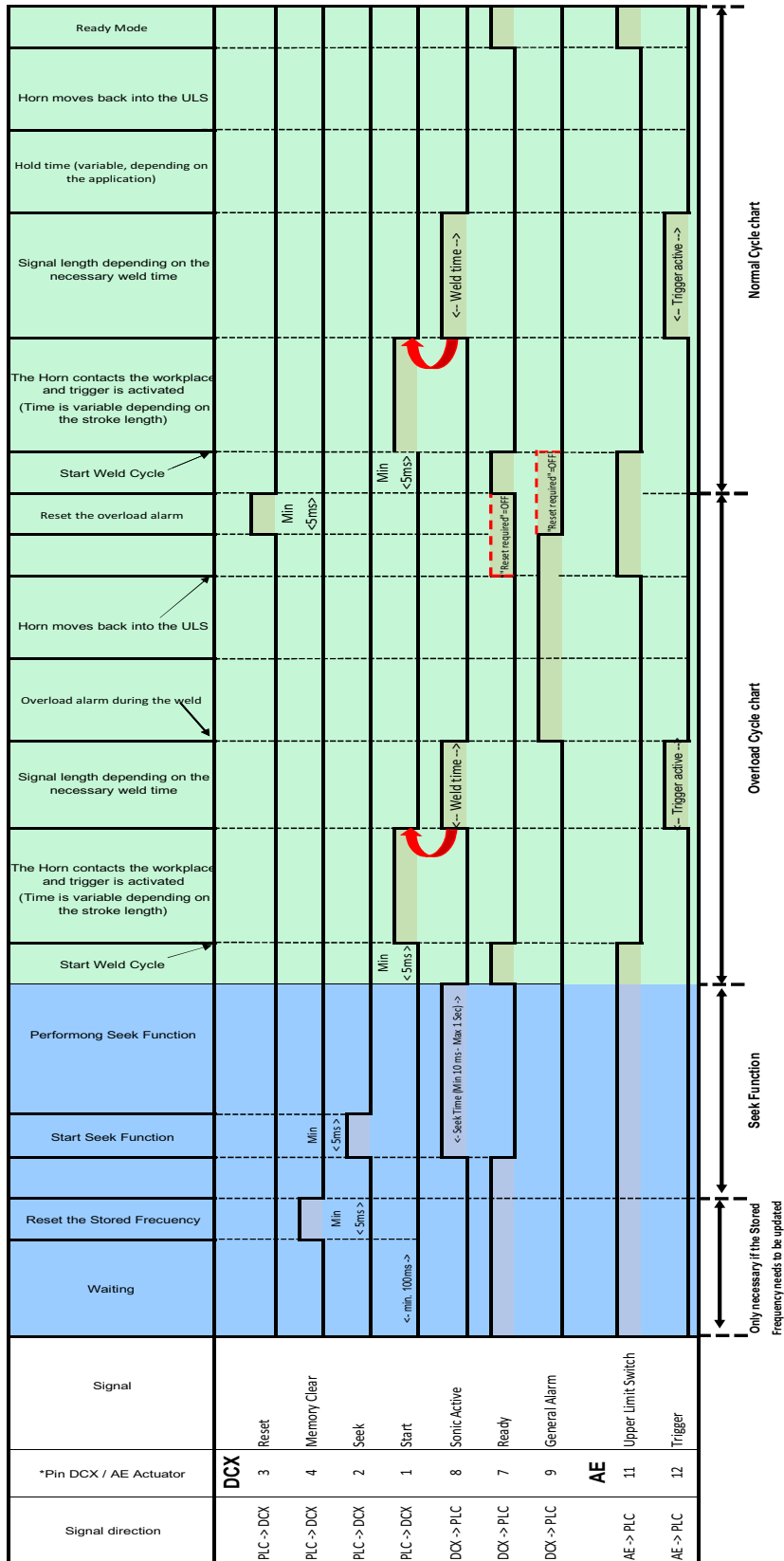

*Inputs/Outputs are configurable on the User I/O Configuration webpage.

↻ Start signal should be released by Sonic Active

--- If Reset Required is unchecked for Overload in Alarm Webpage interface, Ready signal will be enabled when Upper Limit Switch becomes active.

Index

Numerics

24 V Indicator 20

A

Actuator 18, 26
Afterburst 72
Alarm 26
Alarm Commands 189
Alarm Icon 23
Alarm Reset Key 19
Alarms 109, 165
Amplitude 26, 107
Amplitude Control 26
Analog Input Functions 64
Analog Output Functions 65
Assembling the Acoustic Stack 73
Autotuning 17

B

Booster 18, 26, 93
Boosters 157
Branson
 how to contact 7

C

Cables 33
Circle Icon 23
Circuit Breaker / Power Switch 24
Clamping Force 26
Cold Start 26, 164
Communication 125
Communication Channel 201
Communication Channel (PKW) 126
Communication Failure Alarms 176
Compatibility 16
Configuration Key 19
Connecting Tip to Horn 77
Connections 24
Continuous 96
Continuous Mode 97
Continuous Mode Icon 21
Control Word (STW1) 135
Control Word (STW2) 138
Controls and Indicators 19
Converter 18, 26
Converter Cooling 78
Converters 156
Converters and Boosters 83

- Counters 26
- Cutoff Alarms 168
- Cutoffs 72
- Cycle Modified Alarms 170

D

- DCX Inputs/PLC Outputs 143
- DCX Outputs/PLC Inputs 139
- Declaration of Conformity 39
- Degating 26
- Delivery and Handling 29
- Digital Amplitude Setting 17
- Digital Input Functions 61
- Digital Output Functions 63
- Drop Test 30

E

- Electrical Connections 56
- Electrical Problems 161
- Electrical Specifications 36
- Emissions 5
- End of Weld Store 72
- Energy 96
- Energy Brake 72
- Energy Director 26
- Energy Mode 100
- Energy Mode Icon 21
- Environmental Requirements 52
- Environmental Specifications 30, 36
- Equipment Failure Alarms 173
- Ethernet Port 20, 24
- External Amplitude Control 26, 108
- External Frequency Control 26

F

- Features 17
- Fieldbus 26
- Fixture 26
- Flash 26
- Forming 26
- Frequency 26
- Frequency Offset 17, 26, 72
- Fretting Corrosion 26
- Front Panel 19

G

- Gain 26
- General Maintenance 148
- General Precautions 4
- Glossary 26
- Ground Detect 96
- Ground Detect Icon 22
- Ground Detect Mode 105
- Ground Screw 24

H

- Hardware Alarms 177
- Horizontal (Benchtop) Mounting 54
- Horn 18, 26, 93
- Horn Amplitude 26
- Horn Signature 17, 26
- how to contact Branson 7
- Humidity 30

I

- I/O Connections 119
- I/O Image 126
- Implicit Message for Reset 145
- Implicit Message for Run 144
- Implicit Message for Scan 144
- Implicit Message for Seek 144
- Implicit Messaging 134
- Input Power Connection 70
- Input Power Ratings 52
- Insertion 26
- Installation and Setup 45
- Installation Requirements 47
- Installation Steps 53
- Intended Use of the System 4
- Interface 26
- Introduction 13
- Inventory 33

J

- Joint 26
- Joule Icon 22

L

- LCD 19
- LCD (Liquid Crystal Display) 17
- LCD Bar-Graph 114
- LED Status Indicator 122
- Limit Alarms 172
- Limits 72
- Line Input Connector 24
- Line Regulation 17
- Load Regulation 17
- Location 47

M

- Maintenance 147
- Membrane Keys 17
- Mode 72
- Mount the Power Supply 53
- Mounting Considerations 54

N

- Network Connectors 123
- Network Segment Length 124
- Network Topology 123

No Cycle Alarms 175
Non-Cycle Overload Alarms 178
Number Sign Icon 22
Numeric Display 21

O

Operation 95
Output Power 69
Overload Alarms 166

P

Parameter 26
Parameter Range 26
Passcodes 17
Peak Power 96
Peak Power Icon 22
Peak Power Mode 103
Percentage Icon 22
Physical Description 38
PIN Assignments 66
PKW 126
Pneumatic Requirements 52
Power Supply 17, 27
Power Supply Setup 72
Power Up 72
Power/Frequency Bar-Graph 23
Power-On Indicator 20
Preventive Maintenance 150
Primary Parameters 96
Process Data Channel 131
Process Data Channels 199
PROFIBUS DP 17, 27, 122
PROFIBUS DP Commands 181
PROFIBUS DP Connector 20
PROFIBUS DP Operation 121
PROFIBUS DP Status Indicator 20
PZD Area 131

R

Ramp Starting 17
Receiving 31
Recondition the Stack 150
Registers 110, 111
Regulatory Compliance 5
Returning 34
RF Connector 24

S

Safety and Support 1
Scan Parameter Status 197
Scan Stack Commands 198
Scan Stack Parameters 188
Seek 17, 27
Seek Parameter Status 193
Seek Ramp 72

- Seek Stack Commands 194
- Seek Stack Parameters 186
- Seek Time 72
- Setup 72
- Setup Alarms 169
- Shipping and Handling 30
- Shock / Vibration (transit) 30
- Solid Mount Boosters 93
- Sonics Active Indicator 22
- Spare Stock 155
- Spares 155
- Stack Function 143
- Stack Reconditioning 151
- Stack Torque Values 152
- Staking 27
- Start Ramp 72
- Start-up Diagnostics 17
- Status Word (ZSW1) 140
- Status Word (ZSW2) 143
- Storage / Shipping Temperature 30
- Stud Torque Values 154
- STW1 135
- STW2 138
- Swaging 27
- Symbols 2
- System Cables 155
- System Protection 17

T

- Technical Specifications 35
- Test Parameter Status 195
- Test Stack Commands 196
- Test Stack Parameters 187
- Testing 80
- Thermoset 27
- Time 96
- Time Icon 22
- Time Mode 98
- Time Mode Icon 21
- Timed Seek 18, 72
- Timing Diagrams 205
- Token 27
- Token Access 201
- Troubleshooting 161
- True Wattmeter 18

U

- Ultrasonic Power 27
- Ultrasonic Power Problems 162
- Ultrasonic Stack 92
- Ultrasonic Welding 27
- Ultrasonics Test Key 20
- Ultrasonics Test Procedure 117
- Unpacking 32
- Up/Down Keys 19
- User I/O Cable Pin Assignments 60

User I/O Connections 57
User I/O Connector 24
User ID 17, 27

V

Version, System, & RTC Information 202
Vertical Mounting 54

W

Warning Alarms 171
Warnings 2
Web Page Interface 18
Weld Amplitude 72
Weld Cycle Problems 163
Weld Parameter Status 190
Weld Parameters 182
Weld Status Commands 192
Weld System 27
Welding System 17
Welding Systems 25

Z

ZSW1 140
ZSW2 143