

# Fisher™ 4660 High-Low Pressure Pilot

The Fisher 4660 pneumatic high-low pressure pilot activates safety shutdown systems for flowlines, production vessels, and compressors. This pilot is available with either single or dual set point capability, using switch points to maintain full output pressure when the process pressure is within the set point range. If the process pressure is outside this range, the pilot switches from full output pressure to zero output pressure.

The primary switching mechanism in this pilot is a block-and-bleed relay assembly. This construction can be used in both block-and-bleed and bleed-only systems.

Unless otherwise noted, all NACE references are to NACE MR0175-2002.



X0231

FISHER 4660 HIGH-LOW PRESSURE PILOT  
WITH BLOCK AND BLEED RELAY

## Features

- **Safety Certification**—The 4660 is certified for use in Safety Instrumented System (SIS) applications. Certification is by exida Consulting LLC, a global provider of functional safety and control system security (see figure 1). SIS certification is identified on the product by a label affixed to the case.
- **Superior Performance**—Repeatability meets the U.S. Minerals Management Service test tolerances referenced in Outer Continental Shelf (OCS) Order No. 5 and defined in the American Petroleum Institute (API) RP14C standard.
- **Cost-Effective Design**—One pilot provides either a high-low function or a single switch point, whichever the application requires.

The functional safety assessment was performed to the requirements of IEC 61508: ed2, 2010, SIL3 for mechanical components.

Figure 1. exida Certificate

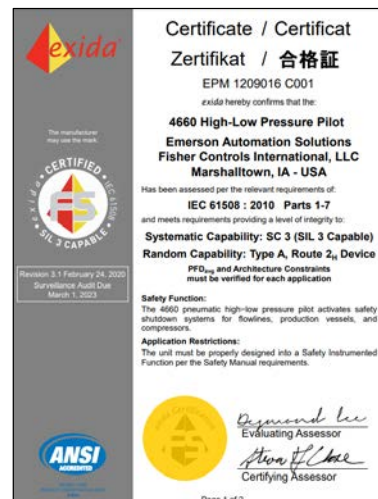

- **NACE Conformance**—A NACE compliant Bourdon tube is available for those applications where the pilot must meet the requirements of NACE MR0175-2002.
- **Environmental Packaging**—Construction materials have been selected to protect the pilot from corrosive environments such as the salt spray atmosphere of offshore platforms.
- **Reliable Operation**—The pilot uses a field-proven Bourdon tube process pressure sensing element, shown in figure 2, that reduces maintenance by eliminating the need for wetted dynamic O-rings.
- **Reduced Air/Gas Consumption**—The 4660 pneumatic high-low pressure pilot is an energy efficient choice. The low bleed relay provides a steady state consumption rate that is less than the 6 scfh requirement set for the oil and gas industry by the US Environmental Protection Agency (New Source Performance Standards Subpart OOOO, EPA-HQ-QAR-2010-0505).
- **Vibration Resistance**—The rugged Bourdon tube sensing element and shock-absorbing switch points dampen the effects of vibration while maintaining performance.
- **Set Point Accuracy**—Standard high-resolution set point adjustments are easy to set, non-interactive, and can be locked in place to maintain the desired set point. The optional set point indication assemblies on the front panel are easy to read and let you simply dial in the desired set point.

Figure 2. Fisher 4660 High-Low Pressure Pilot with Block and Bleed Relay; Left Side with Case Cover Off

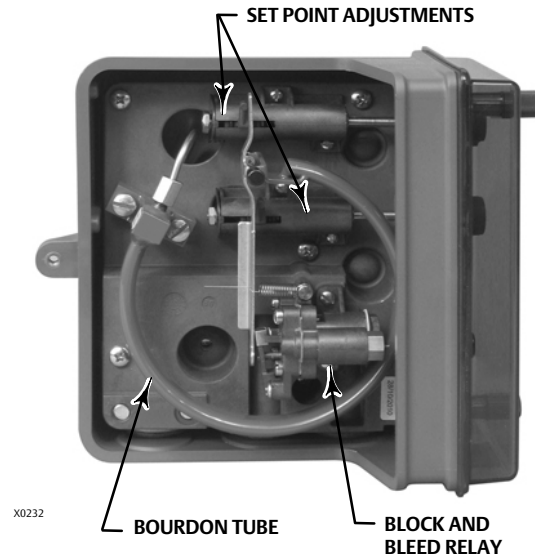

- **Easy Maintenance**—Simple modular construction plus a line of prepackaged parts kits makes pilot maintenance fast and easy.
- **Installation Versatility**—Panel, rack, pipestand, or actuator mounting is available to meet field requirements.
- **Operational Indications**—A supply pressure test function is provided. The optional output indicator lets you check at a glance whether the pilot output pressure is at full output or zero output pressure.

**Table of Contents**

Features .....	1	Installation .....	7
Principle of Operation .....	6	Ordering Information .....	11
Performance .....	6	Application .....	11
Applications .....	7	Construction .....	11

## Specifications

### Available Configurations

- High-low, ■ low-only, or ■ high-only set point capability

### Input Signal

Type: Process pressure sensed with a Bourdon tube  
 Bourdon Tube Ratings: See table 1 or 2  
 Overpressure Protection: Maximum allowable emergency process pressures and maximum allowable process pressures to ensure set point readjustability are shown in table 3

### Output Signal

- Zero pressure or ■ full supply pressure (automatically resets)

### Supply Pressure<sup>(1)</sup>

Normal Operating Pressure: 1.4 to 4.4 bar (20 to 65 psig)

Medium: Air or Natural Gas

Supply medium must be clean, dry, and noncorrosive

### Steady-State Air Consumption<sup>(2)</sup>

Output Signal at 0 psig:  $\leq 0.134$  normal  $m^3/hr$  ( $\leq 5$  scfh)

Output Signal at Full Supply Pressure:  $\leq 0.00134$  normal  $m^3/hr$  ( $\leq 0.05$  scfh)

### Set Point Adjustments

Continuously adjustable between 3% and 97% of Bourdon tube rating; see table 1 or 2 for ranges

### Performance in Percentage of Bourdon Tube Rating

Repeatability:  $\leq 0.25\%$

Set Point  $\Delta P_{min}$   
(See table 1 or 2)

Single High-Low Unit: 10% for up to 170 bar (2500 psig) Bourdon tubes; 15% for 350, 500, and 700 (NACE) bar (5000, 7500, and 10,000 (NACE) psig) Bourdon tubes

Low-Only and High-Only Pair: 3%

Trip-to-Reset Zone:  $\leq 1.5\%$  (see table 1 or 2)

### Exhaust Capacity

$C_g \geq 15$

### Construction Materials

Case and Cover: Polyester

Front Cover: Tinted polycarbonate with scratch-resistant coating

Base: Hard-anodized nickel-sealed aluminum alloy  
 Bourdon Tube: ■ S31600 SST or ■ NACE compliant material

Relay Body, Relay Flange, Nozzle/Flapper Assembly Orifice Block, and Switch Point Housings: Glass-filled polyphenylene sulfide

Relay Diaphragm: Fluorosilicone/Polyester

Relay Discs: Fluorosilicone

Process Pressure Block, Tubing, Front Plate, Flapper, Linkages, and Other Major Metal Parts: Stainless steel

Gaskets: Chloroprene and nitrile

O-Rings

Relay: Nitrile

Switchpoint Assembly: Nitrile impregnated with molybdenum disulphide

Base/Case: Nitrile

### Operating Conditions<sup>(1)</sup>

Condition	Normal Operating Limits	Nominal Reference
Ambient Temperature	-59 to 71 °C (-75 to 160 °F)	21 °C (70 °F)

### Operating Influences on Switch Point Sensitivity

Supply Pressure:  $\leq 0.05\%$  of Bourdon tube rating for a 10% change in supply pressure

Ambient Temperature:  $\leq 2\%$  of Bourdon tube rating throughout normal operating limits with nominal reference

Time:  $\leq 1\%$  of Bourdon tube rating over 30 days at ambient temperature nominal reference

Process Pressure: Range shift or set point drift can occur if process pressure exceeds the Bourdon tube rating

### Pressure Connections

1/4 NPT internal

### Mounting

- Panel, ■ rack, ■ pipestand, or ■ actuator

-continued-

**Specifications (continued)**

**Hazardous Area Classification**

Complies with the requirements of ATEX Group II Category 2 Gas and Dust

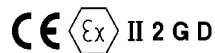

Ex h IIC Tx Gb  
Ex h IIC Tx Db

Maximum surface temperature (Tx) depends on operating conditions

Gas: T6  
Dust: T71

Meets Customs Union technical regulation TP TC 012/2011 for Groups II/III Category 2 equipment

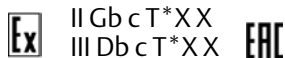

**Safety Instrumented System Classification**

SIL3 capable - certified by exida Consulting LLC

**Approximate Weight**

2.3 kg (5 pounds)

**Options**

- Visual output indication
- stainless steel panel mounting flange,
- set point indication, and
- tamper-resistant front cover

NOTE: Specialized instrument terms are defined in ANSI/ISA Standard 51.1 - Process Instrument Terminology.  
1. The pressure/temperature limits in this document and any applicable standard or code limitation for valve should not be exceeded.  
2. Normal m<sup>3</sup>/h--Normal cubic meters per hour at 0°C and 1.01325 bar, absolute. Scfh--Standard cubic feet per hour at 60°F and 14.7 psia.

**Table 1. Additional Specifications, Bar**

BOURDON TUBE RATING <sup>(1)</sup>	SET RANGE <sup>(1)</sup>	SET POINT $\Delta P_{MIN}$ (MINIMUM ALLOWABLE DIFFERENCE BETWEEN HIGH AND LOW SETTINGS)		TRIP-TO-RESET ZONE
		Single High-Low Unit	High-Only/ Low-Only Pair	
7	0.3 to 6.6	0.7	0.2	≤0.1
17	0.6 to 16.6	1.7	0.5	0.3
35	1.1 to 33.4	3.5	1.0	0.5
70	2.1 to 67.9	6.9	2.1	1.0
100	3.2 to 100.2	10.3	3.1	1.6
170	5.2 to 167.2	17.2	5.2	2.6
350	10.4 to 334.4	51.7	10.3	5.2
500	15.6 to 501.5	70.7	15.5	7.8
700 <sup>(2)</sup>	20.7 to 668.8	103.4	20.7	10.3

1. Rating indicated on Bourdon tube and set range on front panel are in kPa (1 bar = 100 kPa).  
2. Available in NACE compliant material only.

**Table 2. Additional Specifications, Psig**

BOURDON TUBE RATING	SET RANGE	SET POINT $\Delta P_{MIN}$ (MINIMUM ALLOWABLE DIFFERENCE BETWEEN HIGH AND LOW SETTINGS)		TRIP-TO-RESET ZONE
		Single High-Low Unit	High-Only/ Low-Only Pair	
100	3 to 97	10	3.0	≤1.5
250	8 to 242	25	7.5	3.8
500	15 to 485	50	15	7.5
1000	30 to 970	100	30	15
1500	45 to 1455	150	45	23
2500	75 to 2425	250	75	38
5000	150 to 4850	750	150	75
7500	225 to 7275	1025	225	113
10,000 <sup>(1)</sup>	300 to 9700	1500	300	150

1. Available in NACE compliant material only.

Table 3. Maximum Allowable Process Pressure<sup>(1)</sup>

BOURDON TUBE RATING		MAXIMUM ALLOWABLE EMERGENCY PROCESS PRESSURE			
Bar <sup>(2)</sup>	Psig	Stainless Steel Bourdon Tubes		NACE Compliant Bourdon Tubes	
		Bar <sup>(2)</sup>	Psig	Bar <sup>(2)</sup>	Psig
6.9	100	13.8	200	13.8	200
17.2	250	34.2	500	34.2	500
34.5	500	69.0	1000	69.0	1000
69.0	1000	138.0	2000	138.0	2000
103.4	1500	206.8	3000	206.8	3000
172.4	2500	344.8	5000	258.6	3750
344.8	5000	517.2	7500	430.9	6250
517.2	7500	646.3	9375	568.8	8250
689.5	10,000	N/A	N/A	758.5	11,000
Maximum Allowable Process Pressure to Ensure Set Point Readjustability <sup>(3)</sup>					
6.9	100	13.8	200	13.8	200
17.2	250	34.8	500	22.3	325
34.5	500	51.7	750	53.4	775
69.0	1000	103.5	1500	89.7	1300
103.4	1500	155.1	2250	124.0	1800
172.4	2500	172.4	2500	227.5	3300
344.8	5000	517.2	7500	344.8	5000
517.2	7500	646.3	9375	517.2	7500
689.5	10,000	N/A	N/A	689.5	10,000

1. Normal operating process pressures should not exceed the Bourdon tube rating.  
2. Ratings indicated on Bourdon tube are in psig and kPa (1 bar = 100 kPa).  
3. Values listed for the NACE compliant Bourdon tubes are for a 2% deviation from set point due to overpressure.

Figure 3. Principle of Operation Schematic

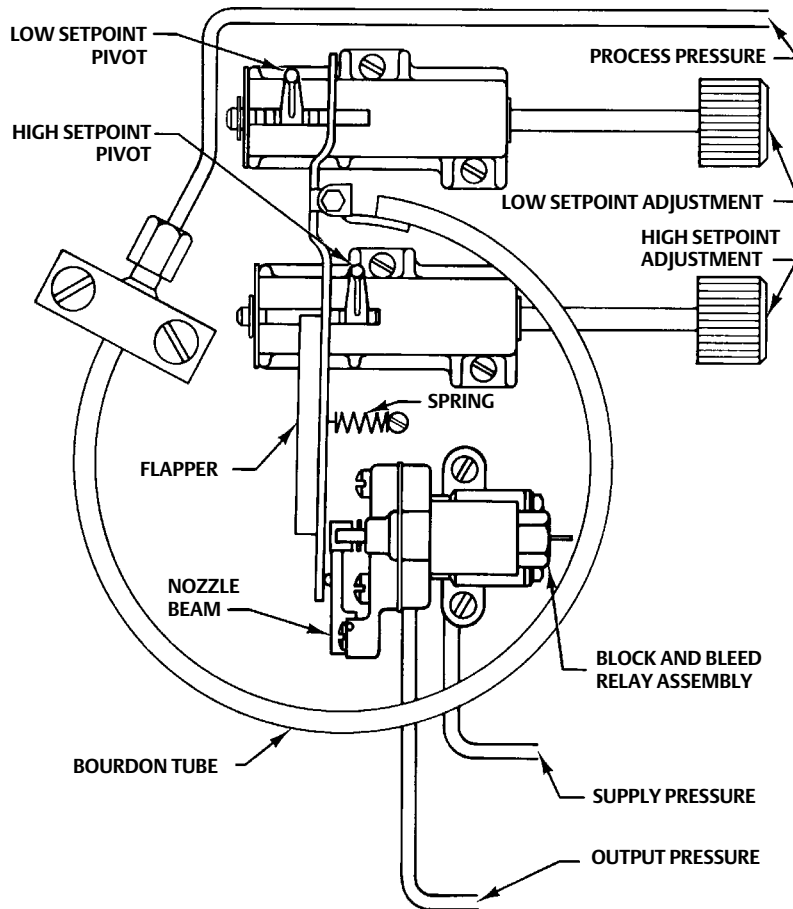

38A3803-A  
A2898-2

## Principle of Operation

Refer to figure 3.

Process pressure is connected to the Bourdon tube sensing element. While the process pressure remains in the adjusted set ranges (between the low set point and the high set point), the flapper does not contact either set point pivot. This keeps the nozzle capped and maintains full output pressure.

As the process pressure decreases below the low set point value, the radius of arc of the Bourdon tube contracts. This causes the flapper to contact the low set point pivot and uncap the nozzle, which blocks supply pressure and vents (bleeds) output pressure. As the process pressure increases above the high set

point value, the radius of arc of the Bourdon tube extends. This causes the flapper to contact the high set point pivot, also uncapping the nozzle and providing block-and-bleed action. When the process pressure returns to the set range, the nozzle is again capped, switching the relay back to maintain full output pressure.

## Performance

The performance characteristics discussed in the Performance in Percentage of Bourdon Tube Rating specification on page 3 and shown in figure 4 illustrate several important functional parameters.

$S_L$  represents the low set point and  $S_H$  represents the high set point. The set range capability is 3 to 97 percent of the Bourdon tube rating. However, with a single high-low unit or a high-only/low-only pair, there is a limit on how close to each other the set points can be adjusted. This limit is defined as set point  $\Delta P_{MIN}$  and is shown as  $S_L'$  and  $S_H'$ .

Trip-to-reset is the combined effect of pilot deadband and hysteresis. After the pilot has tripped, it automatically resets when the process pressure returns to the set range. However, full output pressure is not instantaneous. The difference between the set point and reset to full output pressure is the trip-to-reset zone. This parameter is also a function of the Bourdon tube rating as shown in figure 4 and discussed in the Performance in Percentage of Bourdon Tube Rating specification on page 3.

Repeatability is the switch point deviation around the set point as a percentage of the Bourdon tube rating.

Figure 4. Performance Characteristics

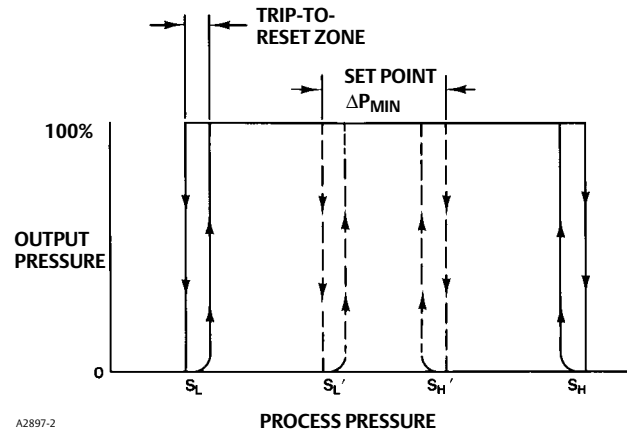

A2897-2

## Applications

Figure 5 shows some of the many ways in which the 4660 high-low pressure pilot may be connected to accommodate requirements for single and dual outputs as well as single and dual process pressure lines. Examples A and D in figure 5 show how a pair of high-only and low-only pilots are connected to obtain closer set points as specified by the set point  $\Delta P_{MIN}$  values in tables 1 and 2. Example B or C shows connections for a two-segment flow line configuration that adheres to API Specification RP14C. Example E shows a typical connection to an electrical pressure switch.

## Installation

Normal installation is with the pilot mounted vertically and the connections for process pressure, supply pressure, and output pressure facing down. The supply medium should be regulated dry air or natural gas with solid particles removed.

Figures 6 and 7 illustrate the mounting dimensions and the location of the pressure connections.

Figure 5. Typical Connection Schematics

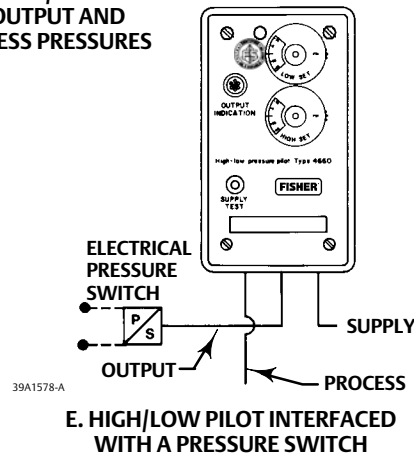
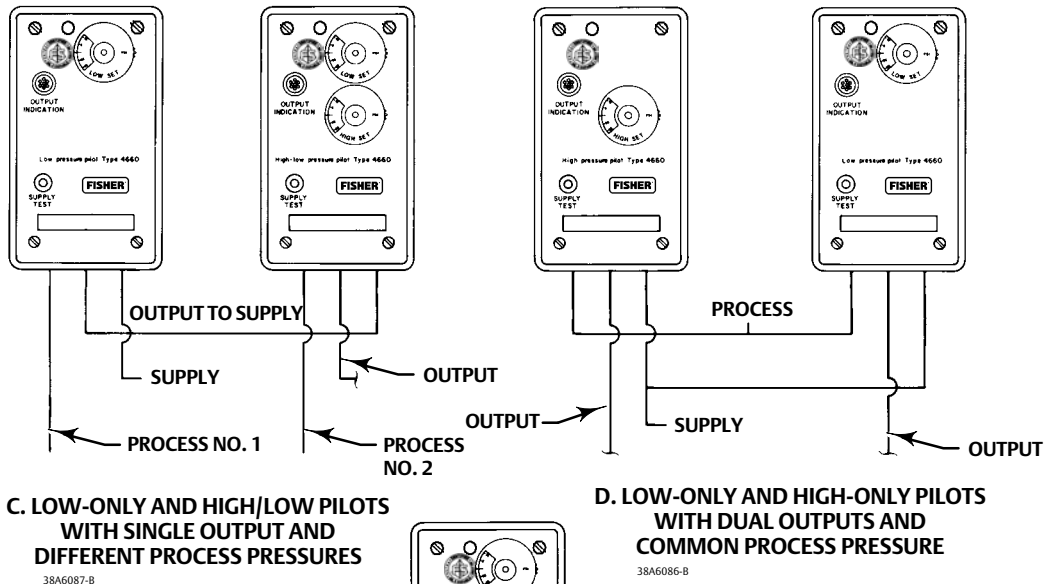
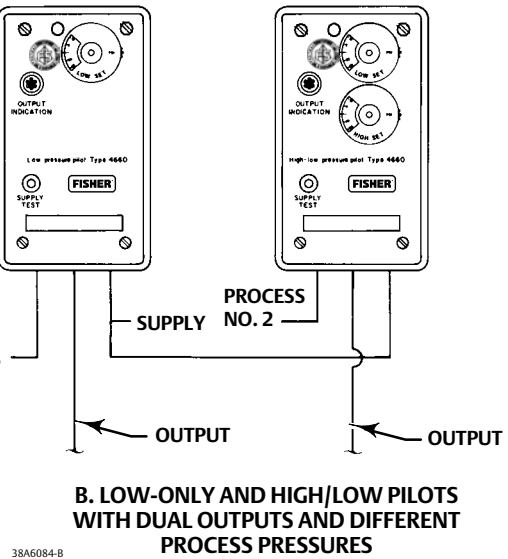
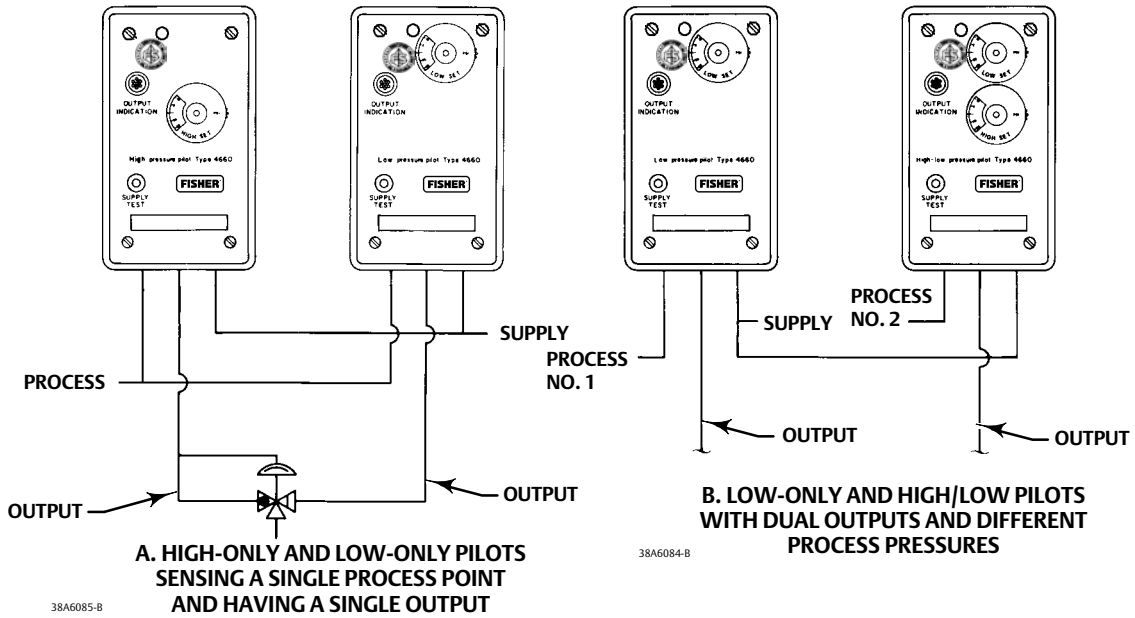
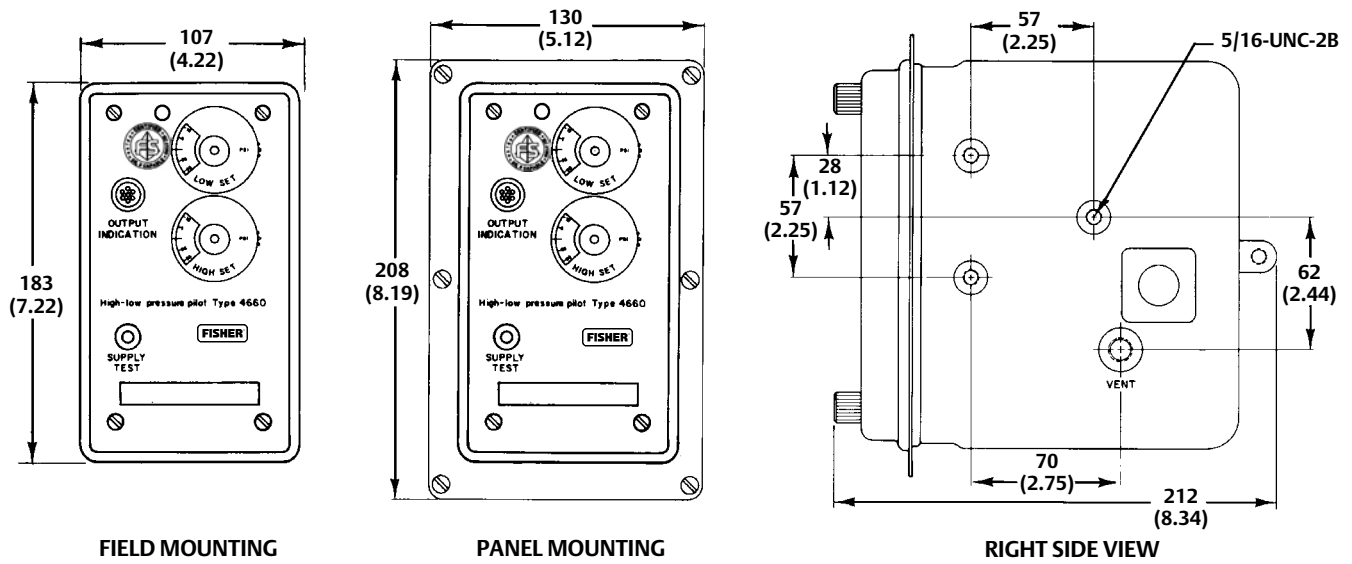

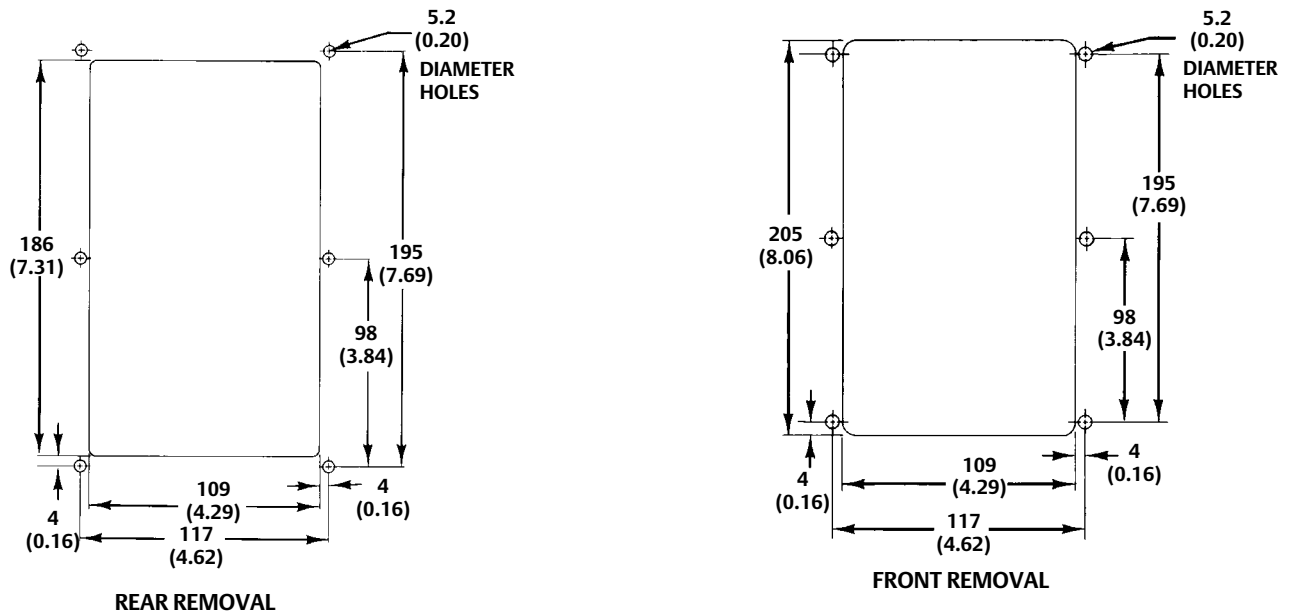

Figure 6. Panel Mounting Dimensions



Note:  
All connection are 1/4 NPT.

39A1578-A  
18A3804-G  
B1589-3



18A3804-F  
A3299-1

mm  
(INCH)

Figure 7. Pipestand Mounting Dimensions

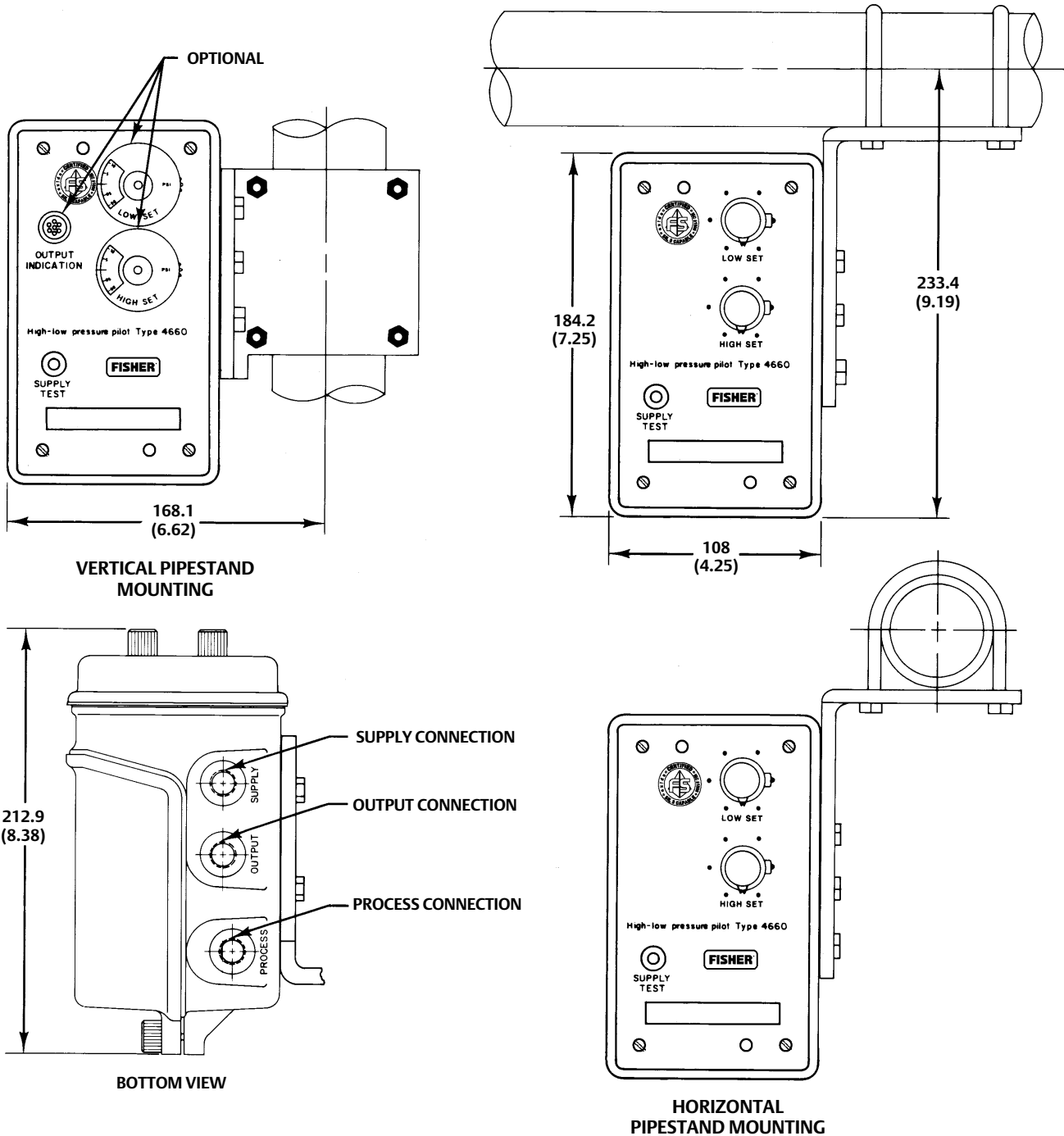

1082287-B  
B1965

mm  
(INCH)

## Ordering Information

When ordering, specify:

### Application

- Bourdon tube rating and material
- Composition, pressure, and temperature of the process fluid

- Ambient temperature range
- Description of application

### Construction

Refer to the Specifications table. Review the information under each specification and in the referenced tables; specify the desired selection whenever there is a choice to be made.

Neither Emerson, Emerson Automation Solutions, nor any of their affiliated entities assumes responsibility for the selection, use or maintenance of any product. Responsibility for proper selection, use, and maintenance of any product remains solely with the purchaser and end user.

Fisher is a mark owned by one of the companies in the Emerson Automation Solutions business unit of Emerson Electric Co. Emerson Automation Solutions, Emerson, and the Emerson logo are trademarks and service marks of Emerson Electric Co. All other marks are the property of their respective owners.

The contents of this publication are presented for informational purposes only, and while every effort has been made to ensure their accuracy, they are not to be construed as warranties or guarantees, express or implied, regarding the products or services described herein or their use or applicability. All sales are governed by our terms and conditions, which are available upon request. We reserve the right to modify or improve the designs or specifications of such products at any time without notice.

Emerson Automation Solutions  
Marshalltown, Iowa 50158 USA  
Sorocaba, 18087 Brazil  
Cernay, 68700 France  
Dubai, United Arab Emirates  
Singapore 128461 Singapore

[www.Fisher.com](http://www.Fisher.com)

