

# Fisher™ Dirty Service Trim for Out-Gassing Applications (DST-G)

Fisher Dirty Service Trim for out-gassing applications (DST-G) is a multi-stage control valve trim design. It is used in services where the fluid has dissolved gases that are released from the solution due to a reduction in pressure and may also contain entrained particulate. DST-G is mainly used in Refining and Oil & Gas applications.

## Features

- **Out-gassing Control**— Multi-stage DST-G, used in a valve properly selected for flow conditions, can minimize effects from out-gassing and associated damage, vibration, and noise.
- **Long Trim Life**— The trim concept uses a combined axial and radial flow that features large, open flow paths similar to the standard multi-stage DST. The lower cage utilizes large slots to separate the flow into smaller jets containing less energy and therefore extending trim life.
- **Easy Maintenance**— Inline trim removal allows inspection of parts without taking the valve body out of the pipeline.
- **Trim Materials**— Standard trim materials consist of a plug, seat ring, and upper cage fabricated from 316 SST with Alloy 6 hardfacing, and a lower cage machined from solid Alloy 6. Additional trim combinations can be found in table 2.
- **Shutoff**— DST-G also features a protected seat design where the shutoff function of the trim is separate from the throttling areas. DST-G comes standard with class V shutoff.



W9607

Fisher DST-G Plug and Cage

Specifications

**Available Valve Sizes**

See table 1

**End Connection Styles**

CL150 through CL2500 raised-face or ring-type joint flanges per ASME B16.5

For other end connections, contact your [Emerson sales office](#) or Local Business Partner for details

**Shutoff Classification**

Class V: per ANSI/FCI 70-2 and IEC 60534-4

**Maximum Inlet Pressures and Temperatures<sup>(1)</sup>**

Consistent with applicable pressure/temperature ratings according to ASME B16.34 unless limited by individual temperature limits shown in table 2

**Maximum Pressure Drop<sup>(1)</sup>**

Standard: 2500 psid unless limited by applicable pressure/temperature ratings in accordance with ASME B16.34 guidelines

**Optional:** Contact your Emerson sales office or Local Business Partner for pressure drops greater than 2500 psid

**Construction Materials**

See table 2

**Temperature Capabilities**

**Valve Body/Trim Combinations:** See table 2

**All Other Parts:** Consult your Emerson sales office or Local Business Partner

**Flow Characteristic**

Linear

**Flow Direction**

Flow down

**Flow Coefficients**

Typical maximum and minimum flow coefficients can be found in table 1

**Noise Levels**

Noise level is expected to be less than 80 or 85 dBA

1. The pressure/temperature limits in this bulletin and any applicable standard or code limitation should not be exceeded.

**Contents**

Features .....	1
Specifications .....	2
Principle of Operation .....	3
Availability .....	3
Trim Selection Guidelines .....	3
Characteristics .....	3

Tables	
DST-G Availability and Capacities .....	6
Typical Trim Combinations for DST-G .....	6

## Principle of Operation

Throughout the process industry, certain valve applications experience the phenomenon of out-gassing as the flowing media passes through the control valve. Out-gassing is the process by which gases dissolved in a fluid come out of solution due to a change in pressure. One way to illustrate this concept is to consider a can of soda. At first glance, the soda appears to be a homogeneous liquid. If the can is shaken and opened, the dissolved CO<sub>2</sub> comes out of solution and will fizz or spray out of the can. This occurrence is known as out-gassing.

Out-gassing generally causes two types of damage. One type of damage occurs due to the high velocity jets coming out of solution, which carry small liquid particles. These liquid particles impinge on internal surfaces at very high velocities causing erosion damage. Secondly, the high velocity jets coming out of solution tend to impinge on the body wall and trim parts causing vibration. The jet size is determined by the size of the cage hole/window through which the fluid flows. Breaking up the large jets into smaller jets helps to prevent vibration, as well as damage from entrained particulate.

The DST-G trim employs the basic design from the standard DST trim, but utilizes a different component in place of the lower cage. The slotted lower cage design facilitates smaller jet formation as the jets discharge from the cage into the body expansion area. By separating the jets, damage is prevented by forming many smaller jets that contain far less energy. The large slotted design also allows particles up to 1/4 inch in size to pass through the trim, reducing problems associated with plugging.

The DST-G block forged valve body is also unique whereby it utilizes an expanded body cavity that allows the entrained gases to expand. This expansion reduces the damaging effects of the previously mentioned high velocity jets. The protected seat design also allows the shutoff function of the valve to be separate from the throttling areas of the trim.

## Availability

DST-G comes in a block forged valve body. Typical body sizes and capacities are shown in table 1. The maximum pressure drop across the valve is limited to 2500 psid in standard constructions. Typical applications are shown below.

- Hot high pressure separators (HHPS) letdown
- Cold high pressure separators (CHPS) letdown
- Hot low pressure separators (HLPS) letdown
- Cold low pressure separators (CLPS) letdown
- Rich amine letdown
- Contact your local [Emerson sales office](#) or Local Business Partner for any applications outside of these parameters.

## Trim Selection Guidelines

Refer to table 2 in selecting appropriate trim materials. Trim materials and their corresponding temperature limits are given in table 2. Other materials such as superaustenitic stainless steel, N08825, and tungsten carbide trims are available upon request. Contact your Emerson sales office or Local Business Partner for more information.

## Characteristics

DST-G is designed to have no significant flow characteristic for the first 10-15% of travel in order to allow for the protected seat function, in which no significant pressure drop will occur across the seating surfaces. After 15% of travel, the flow characteristic becomes linear. See figures 1 and 2.

Figure 1. Fisher DST-G in Closed Position

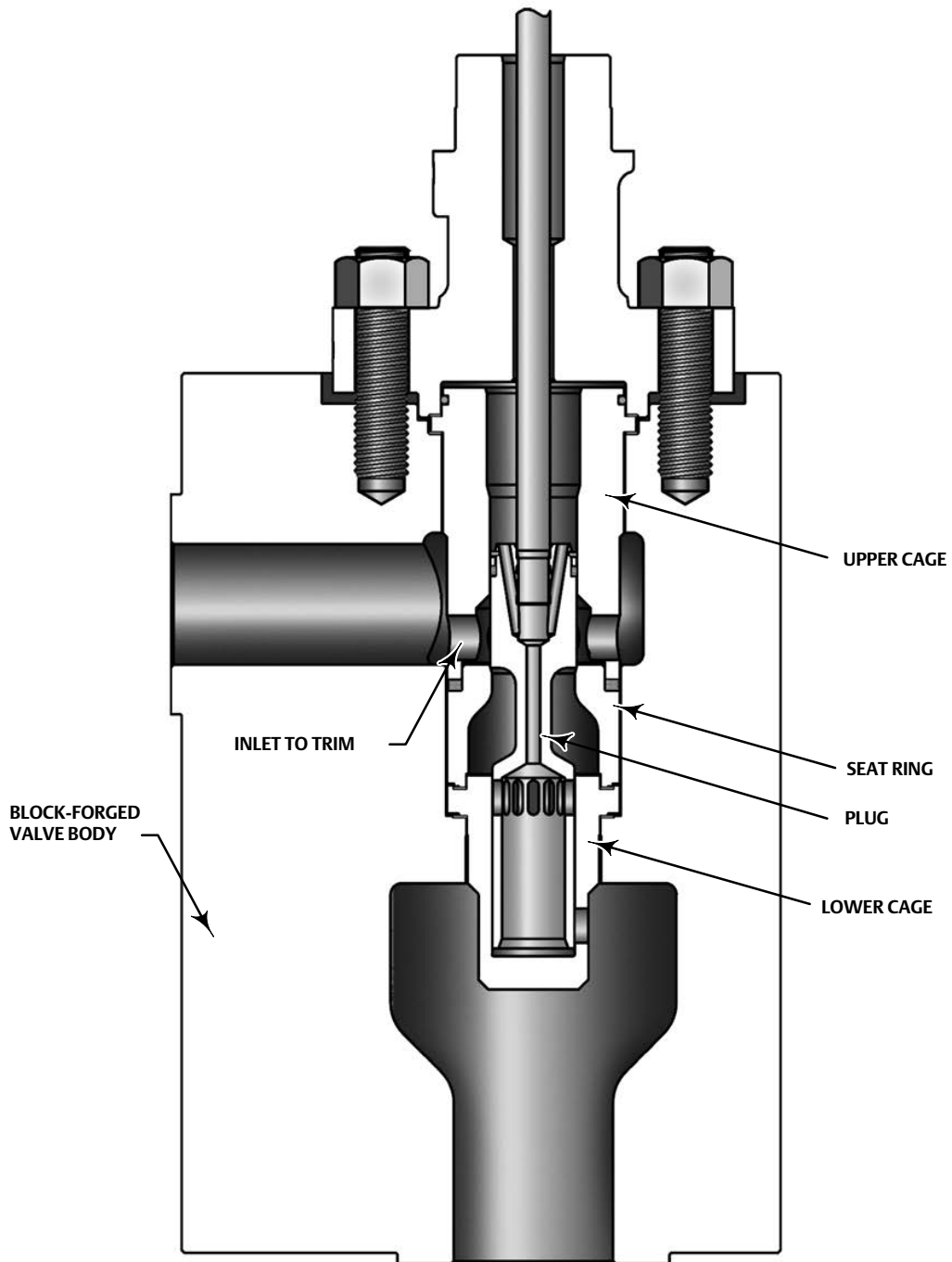

W9626-1

Figure 2. Fisher DST-G in Open Position

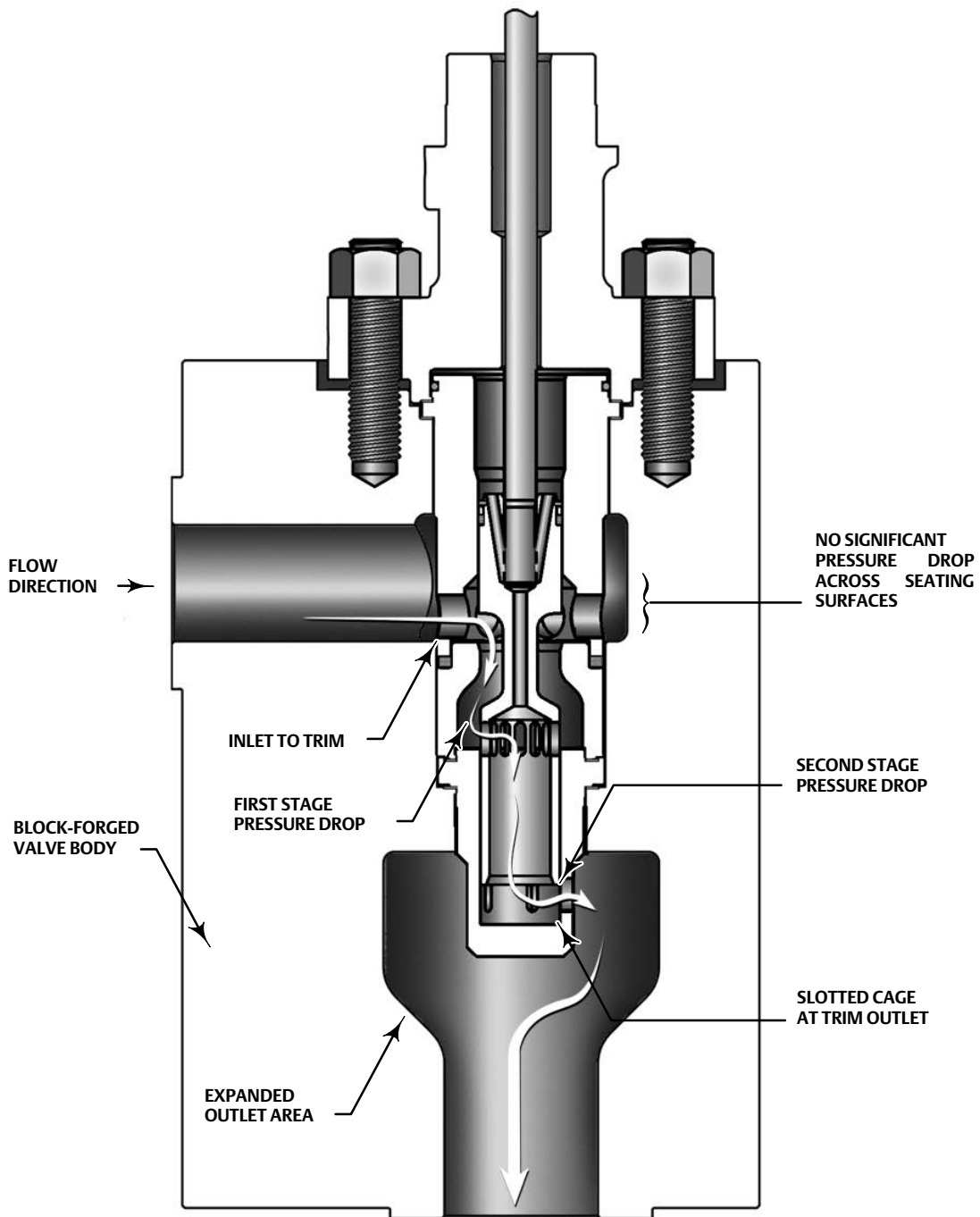

W9625-1

Table 1. Fisher DST-G Availability and Typical Capacities

PRESSURE CLASS	VALVE SIZE	PORT DIAMETER		TRAVEL		MINIMUM Cv	MAXIMUM Cv	UNBALANCE AREA
	NPS	mm	Inch	mm	Inch			Inch <sup>2</sup>
CL150 through CL600	2 2x3	47.6	1.88	19.1	0.75	0.78	32	0.031
	4	73.0	2.88	38.1	1.50	1.4	60	0.047
	6	111.1	4.38	63.5	2.50	2.6	153	0.154
	8	136.5	5.38	101.6	4.00	4	230	0.142
CL900 & 1500	2 3	33.3	1.31 <sup>(1)</sup>	19.1	0.75	0.46	10	---
	2 2x3 3x4	47.6	1.88	19.1	0.75	0.75	17.7	0.031
	3x4 4 6	73.0	2.88	38.1	1.50	1.4	60	0.047
	6 6x8	92.1	3.63	38.1	1.50	1.9	80	0.118
	6 6x8 8	111.1	4.38	50.8	2.00	2.6	130	0.154
	10	111.1	4.38	63.5	2.50	2.6	150	0.054
CL1500 only	8x8	136.7	5.38	76.2	3.00	4.0	180	0.142
CL2500	2	33.3	1.31 <sup>(1)</sup>	19.1	0.75	0.46	10	---
	3	73.0	2.88	38.1	1.50	1.4	60	0.047
	4	92.1	3.63	38.1	1.50	1.9	80	0.118
	6	111.1	4.38	50.8	2.00	2.6	130	0.154
	8	111.1	4.38	63.5	2 1/2	2.6	150	0.154

1. Unbalanced

Table 2. Typical Trim Combinations for Fisher DST-G<sup>(2)</sup>

VALVE BODY/ BONNET MATERIAL	VALVE PLUG	UPPER CAGE	LOWER CAGE	SEAT RING	MAXIMUM TEMPERATURE LIMIT	
					°C	°F
SA105/WCC S31600/CF8M S34700/CF8C S30400/CF8 F22/WC9	316/CoCr-A	316/CoCr-A	CoCr-A	316/CoCr-A	316	600
SA105/WCC F22/WC9	N07718/CoCr-A	N07718/CoCr-A	CoCr-A	N07718/CoCr-A	316	600
F22/WC9 SA105/WCC S31600/CF8M S34700/CF8C S30400/CF8	316/CoCr-A	316/CRCT or 316 ENC	CoCr-A	316/CoCr-A	316 <sup>(1)</sup>	600 <sup>(1)</sup>
SA105/WCC F22/WC9	N06625/CoCr-A	N06625/CoCr-A	CoCr-A	N06625/CoCr-A	316	600

1. CL150 to CL600 valves only.

2. Contact your [Emerson sales office](#) or Local Business Partner for additional trim combinations and higher temperatures.



Neither Emerson, Emerson Automation Solutions, nor any of their affiliated entities assumes responsibility for the selection, use or maintenance of any product. Responsibility for proper selection, use, and maintenance of any product remains solely with the purchaser and end user.

Fisher is a mark owned by one of the companies in the Emerson Automation Solutions business unit of Emerson Electric Co. Emerson Automation Solutions, Emerson, and the Emerson logo are trademarks and service marks of Emerson Electric Co. All other marks are the property of their respective owners.

The contents of this publication are presented for informational purposes only, and while every effort has been made to ensure their accuracy, they are not to be construed as warranties or guarantees, express or implied, regarding the products or services described herein or their use or applicability. All sales are governed by our terms and conditions, which are available upon request. We reserve the right to modify or improve the designs or specifications of such products at any time without notice.

**Emerson Automation Solutions**  
Marshalltown, Iowa 50158 USA  
Sorocaba, 18087 Brazil  
Cernay 68700 France  
Dubai, United Arab Emirates  
Singapore 128461 Singapore

[www.Fisher.com](http://www.Fisher.com)

