

Four-Channel Vibration Analysis with the AMS 2140

Efficient. Fast.

- Finish routes more quickly with efficient data collection
- Simple impact testing

Advanced.

- Find hidden problems with advanced troubleshooting and diagnostic options
- Accurately determine outside vibration sources
- Monitor turbomachinery startups with orbits from two sleeve bearings
- Capture machine or process cycles with four-channel transient waveform
- Animate the machine with four-channel ODS modal analysis to identify structural issues



The AMS 2140 Machinery Health Analyzer makes data collection and advanced analysis easier and more efficient.

Overview

Time is often the critical factor in completing route-based vibration analysis. With potentially thousands of machines to analyze, it's no small task. In addition to completing routes, the maintenance staff often performs certain advanced diagnostics, such as coherence testing, startups/coastdowns, bump tests, cross channel, and structural analysis, to determine machine health and detect developing problems.

Route-based vibration analysis performed using single-, dual-, and even some four-channel analyzers requires placing sensors on machines multiple times per bearing just to get the recommended multi-directional measurements. It's no small task, especially with potentially thousands of machines to analyze.

Don't waste time collecting data that could be spent on more value-added tasks.

Turn route-based vibration analysis into a faster, more efficient process that provides insights for advanced troubleshooting and problem solving. Identify the root causes of your toughest equipment problems.



Use Emerson's patented integral magnet and triaxial accelerometer to capture vibration data in three directions simultaneously. This data, when examined alongside PeakVue data, allows for the earliest detection of developing faults in bearings and gears.

Reduce Measurement Collection Time for Each Machine

Using the four-channel collection capabilities in the AMS 2140, your staff will not only reduce data collection time significantly but will also be able to cover more machines in the plant.

With Emerson's integral magnet triaxial sensor, you can take the horizontal, vertical, and axial measurements simultaneously with a single sensor placement on each bearing of the machine versus the traditional data collection method requiring three sensor placements per bearing. A PeakVue measurement can also be collected to detect deterioration in the machine's bearings. Measurements are now collected 30 % faster than data collection on the AMS 2130. This approach could reduce your total collection time on a machine by more than 50%.

Your staff will have more time to monitor additional machines or can dedicate themselves to higher value tasks like diagnostics and analysis.

Monitor Sleeve Bearings More Efficiently

An orbit plot requires two orthogonal measurements from each sleeve bearing. With a dual-channel analyzer that means monitoring only one sleeve bearing orbit at a time. Using the four-channel AMS 2140 you can simultaneously collect data from two sleeve bearings at a time to more accurately and efficiently detect problems.

The AMS 2140 simplifies creation and analysis of the orbit plot. You can view dual orbit plots on either side of the coupling or dual orbits of both sleeve bearings on a turbine, fan, or other production asset. You will discover how the shaft is moving in relation to the bearing races and detect problems like shaft rubs, oil whirl and oil whip.

The AMS 2140 input adapter enables you to take four-channel measurements during turbomachinery start-ups. Create orbit plots from these measurements to identify any mechanical conditions, such as wobbling, that could lead to machinery damage. With this knowledge, you can identify machinery problems and determine if it is safe to continue the startup of the turbomachinery.



Monitor dual orbit plots from two sleeve bearings on the turbine, fan, or other critical machinery to determine if the startup can continue.

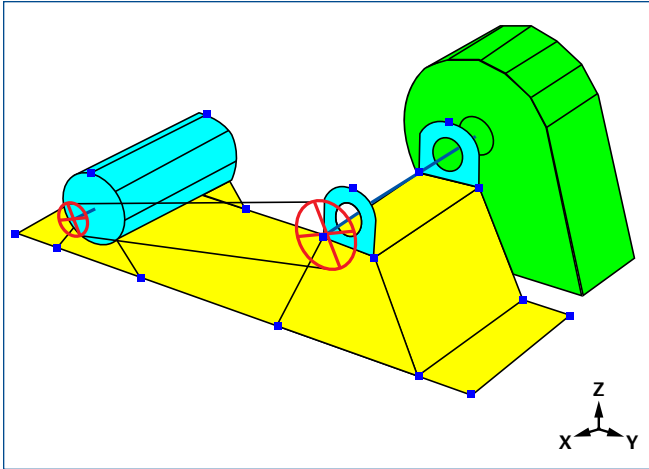

View wireframe animations in ODS software to identify structural problems with the machine during operation.

Simplify Structural Analysis with Animated ODS Modal

ODS (Operational Deflection Shape) Modal analysis produces an animation of how the machine is moving during operation from the measured machine vibration. This helps determine root cause of problems because you can see what the machine is doing as it is running.

When using a dual-channel analyzer and single axis accelerometers, measurements can be difficult and time-consuming – because the sensor needs to be moved to all three orientations at each location for a measurement.

The AMS 2140's simultaneous four-channel collection with the use of Emerson's integral magnet triaxial sensor simplifies the ODS data collection process and can reduce the time required to perform the ODS test by as much as 66%.

The AMS 2140 uses the data to animate a wire diagram showing machinery movement to help you identify the root cause of chronic or complex machinery problems.

Determine Phase Easily

A tachometer used with the AMS 2140 offers an efficient way to measure multiple bearings and show the associated phase reading. This can be used to help determine several machine conditions such as misalignment, resonance, foundation issues, etc. Simply attach a sensor on up to four bearings simultaneously and press enter. The press of one button allows the analyzer to provide phase information for each of the four vibration measurements on the machine.

With the AMS 2140, you have the ability to collect four simultaneous channels of data PLUS phase for those channels. Some four-channel analyzers available in the market require the sacrifice of a data channel in order to also collect phase.

Simplify Impact Testing

Impact testing measurements in three axes provides the most information to determine the resonance for the machine. Traditionally, this would require you to make three individual measurements consecutively with impacts for each measurement. With the four-channel option, however, you can test all impacts and measurements simultaneously. Impact testing can be accomplished quickly and resonance analysis can be performed easily.

Isolate Vibration from Other Sources in One Step

Is the source of vibration coming from the motor you are measuring, or is the vibration coming from another source – maybe the motor to your right? With the four-channel option, you can perform a coherence measurement immediately with the four sensors rather than moving the analyzer sensors from one machine to another and making consecutive measurements.

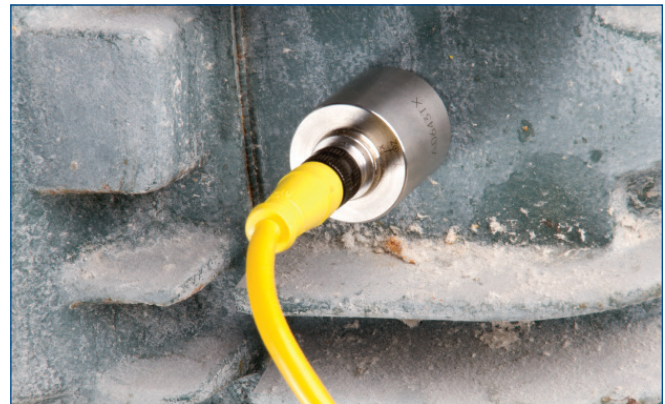

The triaxial accelerometer allows for the collection of vertical, horizontal and axial data from the same location simultaneously.

Four-Channel Accessories Kit Unlocks the Power of the AMS 2140

The four-channel accessories kit includes everything you need to unlock the power of the AMS 2140 four-channel analyzer. Simultaneously collect four-channel acceleration data for rolling element bearings, or four-channel volts data for sleeve bearings from a single input adapter by simply turning it over and using the appropriate side. The adapter is simple to install with a simple tab-click installation on both sides of the analyzer. The kit includes the 4-channel input adapter, cables, accelerometers, and magnets necessary to perform most any kind of 4-channel analysis.



The four-channel adapter snaps easily to either side of the analyzer itself. The padded shoulder strap attaches to the outside of the adapter.



The adapter offers accelerometer inputs on one side, volts inputs on the other.



Splitter cables included in the four-channel accessory kit are another way to collect four-channel simultaneous measurements.

Emerson
Reliability Solutions
 835 Innovation Drive
 Knoxville, TN 37932 USA
 ☎ +1 865 675 2400

🌐 www.emerson.com/ams

©2017, Emerson. All rights reserved.

The Emerson logo is a trademark and service mark of Emerson Electric Co. All other marks are the property of their respective owners.

The contents of this publication are presented for informational purposes only, and while every effort has been made to ensure their accuracy, they are not to be construed as warranties or guarantees, express or implied, regarding the products or services described herein or their use or applicability. All sales are governed by our terms and conditions, which are available on request. We reserve the right to modify or improve the designs or specifications of our products at any time without notice.