

DeltaV™ SQ Controller

- Scalable controllers
- Quick assembly
- Easy-to-use
- Field proven architecture
- Designed for Electronic Marshalling
- Advanced controls



The DeltaV™ SQ Controller and the DeltaV I/O subsystem make rapid installation easy.

Introduction

The DeltaV™ SQ Controllers provides communication and control functions and integrate field devices and the other nodes on the control network. The SX and SQ Controllers provide a choice to match the controller capacity to the requirements of the process. They also provide new ease of use features that eliminate mounting screws and accelerate cabinet assembly.

Control strategies and system configurations created on earlier DeltaV systems can be used with this controller. The SQ Controller provides all the features and functions of the M-series controllers including support for CHARM based Electronic Marshalling.

The control languages executed in the controllers are described in the control software product data sheet.

Benefits

Scalable Controllers. The SQ Controller complements the SX Controller by providing a smaller controller platform at a reduced price for those small to moderate applications:

Speed. The SQ Controller supports all the features you've come to expect from the DeltaV system: self-addressing, automatic I/O detection. All these features are designed to make your projects execute faster — *just plug and play!*

Redundant Architecture. The SQ Controller supports 1:1 redundancy for increased availability. Redundant SQ Controllers can be upgraded to SX Controllers online — *robust!*

Late Changes. You can easily upgrade an SQ Controller to an SX to handle project scope changes late in the project. Simply replace the SQ with the SX and all existing configuration, documentation and hardware design remain the same — *forgiving.*

Quick Assembly. The S-series hardware has been designed for speed of project execution. Carriers snap to standard DIN rails and controllers and S-series I/O snap into position without the use of retaining screws.

Easy to Use. Controllers are also easy to configure. Simply connect the SQ to the DeltaV network and Auto-Sense it from DeltaV Explorer. Add the controller and all its I/O interfaces to the system database and all components are automatically addressed and communicating. There are no dip switches or jumpers to set.

- Control strategies are developed using IEC-61131 programming techniques: Function Blocks, Sequential Function Charts and Structured Text.
- Automatic diagnostic and event reporting with time stamps applied in the controller.
- Set control execution to match process dynamics and controller scheduling adjusts automatically.
- Reference any parameter by its module name, regardless of its location in the system.
- Synchronized system clock for consistent time based event driven actions across the system.
- Online expandable I/O carriers allow new cards to be added online, with autosense capability, for modular system growth.
- Hardware redundancy is automatically detected with zero configuration effort.

Field Proven Architecture. The SQ Controller is an evolution of the DeltaV MQ Controller. The new design delivers installation and robustness enhancement while still using the same processor and OS that has proven itself in the field. All S-series I/O cards run the latest software enhancements of corresponding M-series I/O cards and deliver the same field proven, reliable operation.

Designed for Electronic Marshalling. The SQ Controller have highly distributable I/O capabilities with CHARMS based Electronic Marshalling. Electronic Marshalling I/O can be mounted anywhere, facilitating system design and expansion while reducing overall system footprint over traditional marshalled I/O Subsystems.



The SQ Controller.

Advanced Controls. The SQ Controller supports all the advanced control features that are expected in a world class Distributed Control System:

- Batch Software
- Model Predictive Control
- Neural Networks

Product Description

The SQ Controller executes control logic based on the process signals derived from the I/O subsystem and provides communication to the rest of the DeltaV control system for operator interaction and data collection.

Each controller node can be installed as a simplex or redundant node. Redundancy is provided by adding a second controller and power supply mounted adjacent to the primary controller. The controllers are connected to the I/O carriers, which are mounted to the right of the controller carriers. Up to 8 carriers with 8 cards each can be connected to the local bus I/O, for a total of 64 traditional I/O cards. In addition to the 8 local I/O carriers, each controller can communicate with an additional 16 Remote I/O units hosting traditional card based I/O.

In addition to traditional I/O cards, the local bus supports fieldbus technologies, including FOUNDATION Fieldbus, Profibus DP, DeviceNet and AS-i protocols. The I/O subsystem also supports Serial interface cards as well as the Ethernet I/O interface. These various I/O products provide a wide range of interfaces to meet the needs of your control application.

The SQ Controller also supports CHARMS. The CHARM I/O Card (CIOC) connects via the redundant Ethernet ports of the controller to provide a highly distributed and flexible I/O solution called Electronic Marshalling. Up to 16 CIOC's can communicate to one controller, each providing up to 96 individually configurable signal types.

The capacity limits of the SQ controller may vary depending on the particular application, amount of CHARM I/O Signals and as well control performance requirements. Enhanced memory handling and hardware alerts covering capacity and memory, via indexes, got added to the diagnostic information's of the SQ controller.

Control modules are automatically scheduled by the controller, based on their assigned scan rates. This allows each control function to be optimized based on the process dynamics. Modules scan times can be set as fast as 100 ms, and as slow as 60 seconds. The number of control modules that can be assigned to a controller depends on the complexity and scan rate of each module, and the available CPU and memory. The SQ Controller should be used for small to medium applications with a maximum of 750 individual I/O signals.

The SQ Controller is designed for harsh environments and is rated for G3 corrosive environments, with an operating temperature range from -40 to 70°C. It is ideally suited for remote installation, close to the process equipment. For more traditional installations with central marshalling cabinets, CHARM I/O Cards can be mounted in standard I/O cabinets providing Electronic Marshalling. CHARM I/O Cards can also be used for highly distributed I/O applications.

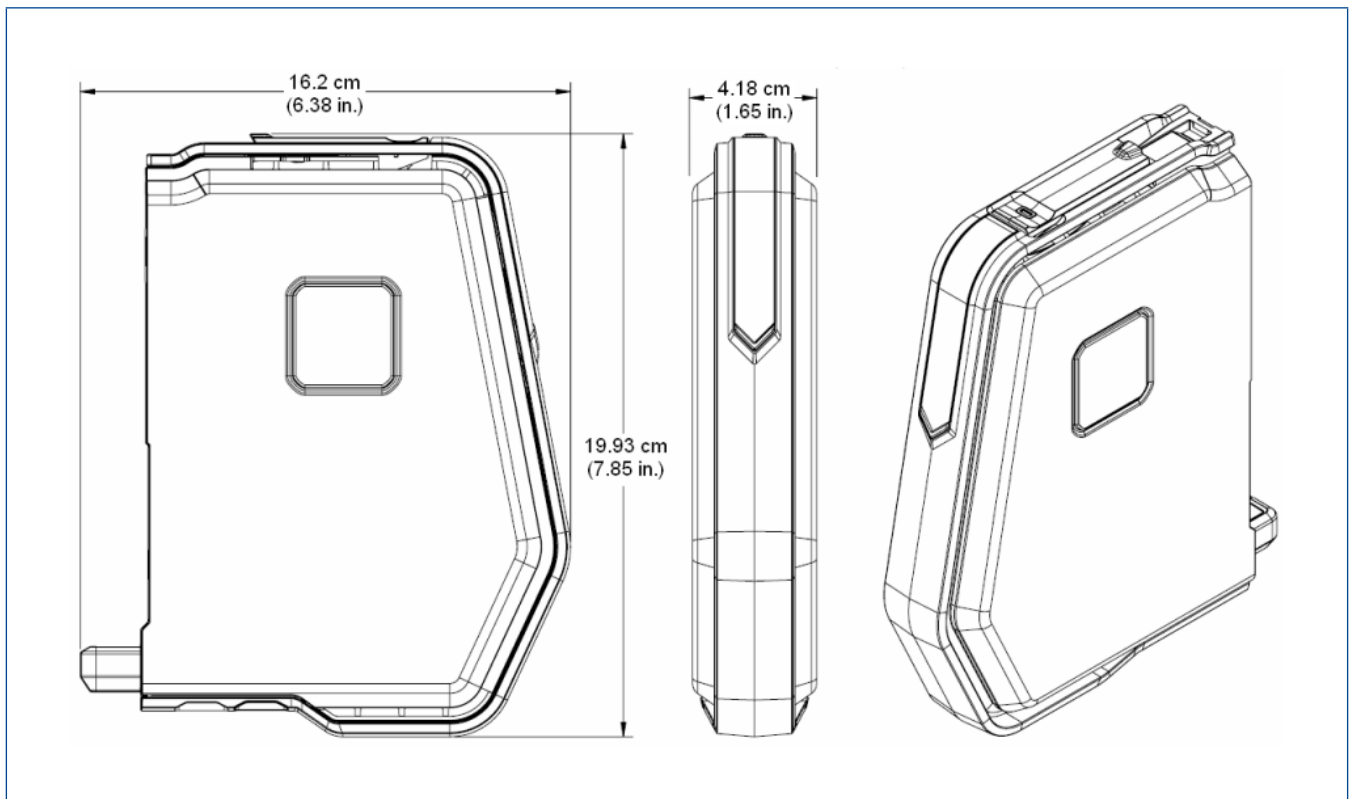

DeltaV SQ Controller hardware dimensions.

Hardware Specifications

Specifications for the SQ Controller	
DST Limit	750
SCADA Tags	3200
Max Data Values Sent	2000/second
Max Data Values Received	250/second
Max Unsolicited Client Nodes	64
Module Execution Rates	100ms, 200ms, 500ms, 1s, 2s, 5s, 10s, 30s, 60s
User Memory	48 MB
Fuse Protection (Internal)	3.0 A, non-replaceable fuses
Power Dissipation	5.0 W typical, 7.0 W maximum
Environmental Specifications	
Operating Temperature*	-40° to 70°C (-40° to 158°F)
Storage Temperature	-40° to 85°C (-40° to 185°F)
Relative Humidity	5 to 95%, non-condensing
Protection Rating	IP 20
Airborne Contaminants	ISA-S71.04-1985 Airborne Contaminants Class G3 Conformal coating
Shock (Normal Operating Conditions)	10 g ½-sine wave for 11 ms
Vibration (Operative Limit)	1 mm peak-to-peak from 5 Hz to 13.2 Hz, 0.7 g from 13.2 Hz to 150 Hz
LED Indicators	
Green – Power	Indicates DC power is applied
Red – Error	Indicates an error condition
Green – Active	Indicates that the controller is operating as the primary controller
Green – Standby	Indicates that the controller is operating as a backup controller
Yellow Flashing – Pri. CN	Indicates valid primary control network communication
Yellow Flashing – Sec. CN	Indicates valid secondary control network communication

External Connections	
Primary Control Network	8-pin RJ-45 connector
Secondary Control Network	8-pin RJ-45 connector

*Operating any electronics at the higher end of its temperature range for long periods of time will shorten its expected lifetime, see **Effects of Heat and Airflow Inside an Enclosure White Paper** for more information.

Certifications

The following certifications are available on the DeltaV SQ Controller (see actual certificates for exact certifications):

■ CE

EMC- EN 61326-1

■ FM

FM 3600

FM 3611

■ CSA

CSA C22.2 No. 213

CSA C22.2 No. 1010-1

■ ATEX

EN 60079-0

EN 60079-7

■ IEC Ex

IEC60079-0

IEC60079-7

■ Marine Certifications: IACS E10

ABS Certificate of Design Assessment

DNV Type Approval Certificate

■ Wurldtech

Achilles Communications Certification Level 2

Hazardous Area/Locations

The DeltaV SQ Controller can be installed and used based on the following Standards (see actual certificates for exact product markings):

■ FM (USA)

Class I, Division 2, Groups A, B, C, D, T4

■ cFM (Canada)

Class I, Division 2, Groups A, B, C, D, T4

■ ATEX

II 3G Ex ec IIC T4 Gc

■ IEC Ex

II 3G Ex ec IIC T4 Gc

Regarding the Installation instructions please refer to the following Documents:

Class 1 Division 2 Installation Instructions DeltaV S-series 12P5402

Zone 2 Installation Instructions DeltaV S-series 12P5404

Ordering Information

Description	Model Number
SQ Controller	SE3008

Prerequisites

- For each controller you will need a Power/Controller Carrier. Please refer to the S-series I/O Carrier product data sheet for details.
- Each controller requires a dedicated system power supply. Please refer to the S-series Power Supplies product data sheet for details.
- The SQ Controller requires DeltaV v11.3.1 or later. A hotfix is required for v11.3.2 and older firmware.

©2024, Emerson. All rights reserved.

The Emerson logo is a trademark and service mark of Emerson Electric Co. The DeltaV logo is a mark of one of the Emerson family of companies. All other marks are the property of their respective owners.

The contents of this publication are presented for informational purposes only, and while diligent efforts were made to ensure their accuracy, they are not to be construed as warranties or guarantees, express or implied, regarding the products or services described herein or their use or applicability. All sales are governed by our terms and conditions, which are available on request. We reserve the right to modify or improve the designs or specifications of our products at any time without notice.

Contact Us

www.emerson.com/contactus