

# Micro Motion™ 820 Electronics

Standard and differential measurement for two Coriolis flow sensors



## Standard and differential measurement for two Coriolis flow sensors

- A complete, dedicated Coriolis meter solution for fuel consumption calculations
- Meets regulatory requirements and custody transfer standards
- Simplified architecture improves reliability and reduces installation costs
- Powerful data log and diagnostics to increase measurement confidence

## Micro Motion™ 820 Electronics

The 820 electronics are specifically designed to meet the challenges of measuring consumption or differential flow between two Coriolis flow sensors. The 820's dedicated design provides an exceptional combination of accuracy, reliability, and value.

### Coriolis meters

Coriolis meters offer dramatic benefits over traditional volumetric measurement technologies. Coriolis meters:

- Deliver accurate and repeatable process data over a wide range of flow rates and process conditions.
- Provide direct inline measurement of mass flow and density, and also measure volume flow and temperature—all from a single device with a remote dual core processor.
- Have no moving parts, so maintenance costs are minimal.
- Have no requirements for flow conditioning or straight pipe runs, so installation is simplified and less expensive.
- Provide advanced diagnostic tools for both the meter and the process.

### 820 electronics

The 820 electronics are targeted for fuel consumption applications including, but not limited to, main engines, auxiliary engines, boilers, among others.

Powerful functions such as security lockout switch, data log, and diagnostics follow stringent regulations and increase the measurement confidence under challenging process conditions.

### Petroleum Measurement

Adds the following calculations to the standard software:

- Calculates base density (corrected API Gravity) and CTL (the correction for the effect of temperature on a liquid)
- Calculates gross volume at standard temperature
- Calculates flow-weighted average temperature and flow-weighted average observed gravity (flowing density)
- Calculates a net temperature for correct volume consumption in conjunction with fuel consumption software

### Weights & Measures Custody Transfer

Adds the following features and standards:

- Physical and software security
- Security alarm posting
- Mass or volume totalizer that is configurable by the user
- Compliant with MID 2004/22/EC Annex MI-002 and Annex MI-005
- Certified by NTEP and OIML

# Operating conditions: Environmental

## Vibration limits

Meets IEC 60068-2-6, endurance sweep, 5 to 2000 Hz, 50 sweep cycles at 1.0 g.

## Temperature limits

Component	Limit
Process fluid temperature	-320 to +140 °F (-196 to +60 °C)
Ambient temperature	-40 to +140 °F (-40 to +60 °C)

## Humidity limits

5 to 95% relative humidity, non-condensing at 140 °F (60 °C).

# Hazardous area classifications

## Approvals and certifications

Type	Liquid or Gas	Approval or certification (typical)
NEPSI	Gas (zone 1)	Ex db [ib] IIB/IIC T6 Gb
Ingress Protection Rating		IP 66/67 for sensors and transmitters IP50 for MVD barrier tightness enclosure IP20 for MVD barrier tightness terminal
EMI effects		Complies with EMC directive 2004/108/EC per EN 61326 Industrial Complies with NAMUR NE-21 (09.05.2012)

### Note

- When a meter is ordered with hazardous area approvals the approved flameproof cable glands must be used. Detailed information is shipped along with the product.
- More information about hazardous approvals, including detailed specifications and temperature graphs for all meter configurations is available on the 820 electronics product page at [www.emerson.com](http://www.emerson.com).

## Industry standards

Type	Standard
Weights and Measures for custody transfer applications:	<ul style="list-style-type: none"> <li>MID OIML R117, R81, and R137</li> </ul>

## Physical specifications

### Materials of construction

General corrosion guidelines do not account for cyclical stress, and therefore should not be relied upon when choosing a wetted material for your Micro Motion electronics device. For material compatibility information, refer to the *Micro Motion Corrosion Guide*.

Components	Specifications	
Housing	Electronic parts	Polyurethane-painted aluminum
Cable gland entrances	Inlets	Two 3/4" NPT female conduit ports for 9-wire connection
	Outlets	Two 1/2"—14 NPT or M20 × 1.5 female conduit ports for outputs and power supply
Mounting	Remote mounting options	

### Weight

Weights provided are the weight of the electronics device with EN1092-1 PN40 F316/316L weld neck flanges not including electrical parts and 9-wire cable.

Model	Description	Weight
820 electronics	Electrical parts	2.9 kg

## Electronics interface

### 820 electronics

The electronic interface code is 820.

#### Electrical connections

Connection	Description
Output connections	Not intrinsically safe type: <ul style="list-style-type: none"> <li>One pair of wiring terminals for RS-485 signal cable connection</li> </ul>
Power connection	<ul style="list-style-type: none"> <li>One pair of wiring terminals accepts 24V DC power</li> </ul>
Sensor connection	Intrinsically safe type: <ul style="list-style-type: none"> <li>Two 9-wire connection channel between sensor and electrical parts</li> <li>One internal ground terminal for 9-wire cable shield ground</li> </ul>
Service port connection	<ul style="list-style-type: none"> <li>Two clips for temporary connection to the service port</li> </ul>
Grounding	<ul style="list-style-type: none"> <li>One external ground terminal for electronics housing ground wiring</li> <li>One internal ground lug for RS-485 cable or power cable shield ground if needed</li> </ul>

#### Note

Each screw terminal connection accepts one or two solid conductors, 14 to 12 AWG (2.5 to 4.0 mm<sup>2</sup>) or one or two stranded conductors, 22 to 14AWG (0.34 to 2.5 mm<sup>2</sup>).

**Digital communications**

Channel	Description
Modbus / RS-485	<ul style="list-style-type: none"> <li>Accepts data rates 4800, 9600, 19200, and 38400 baud.</li> <li>One physical port dedicated to different sensors via different address.</li> </ul>

**Power supply**

Type	Description
DC power	<ul style="list-style-type: none"> <li>18 to 30 VDC, 3 watts typical, 5 watts maximum</li> <li>Minimum 28 VDC with 300 meters of 1 mm<sup>2</sup> power-supply cable</li> <li>At startup, power source must provide a minimum of 0.5 amperes of short term current at a minimum of 18 volts at the electrical parts power input terminals</li> <li>The maximum steady state current is 0.2A</li> </ul>

**Dimensions**

These dimensional drawings are intended to provide a basic guideline for sizing and planning.

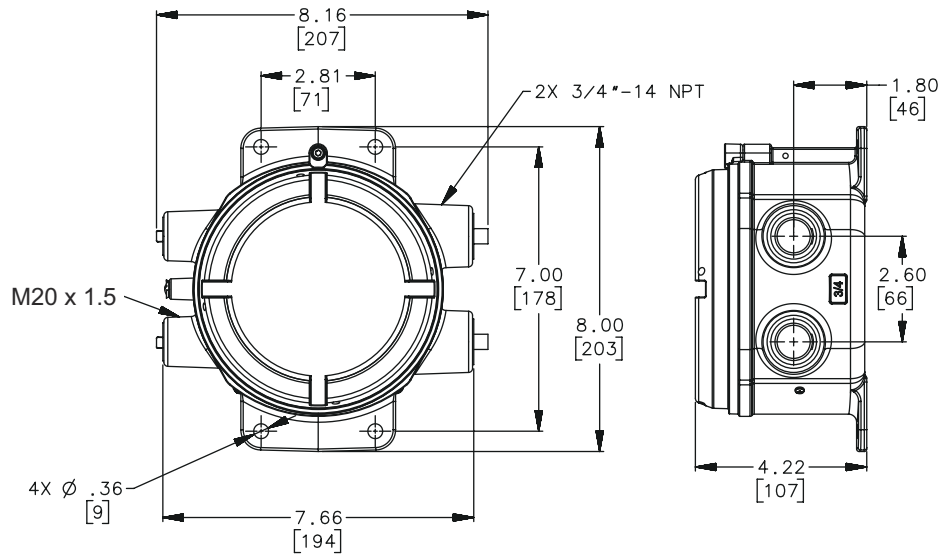

**Note**

- All dimensions are in inches (mm)
- All dimensions ± 0.125 inch (±3 mm)

Cable type	Minimum bending radius			
	Static (no load) condition		Dynamic load condition	
	inch	mm	inch	mm
Jacketed cable	3.13	80	6.25	159
Shielded cable	4.25	108	8.50	216

## Ordering information

This section lists the available options and ordering codes for the product family.

### Model code structure

A complete sensor model code includes the ordering options.

Example code	Description
820	Product description
B	Conduit connections
M	Approvals
FZ	Software measurement application
Z	Future option 1
Z	Future option 2
Z	Future option 3
Z	Factory options

### Product description

Code	Product description
820	820 electronics

### Conduit connections

Code	Conduit connection
B	3/4 inch inlet, 1/2 inch NPT output – no gland
C	3/4 inch input, 1/2 inch NPT output – brass nickel gland
D	3/4 inch input, 1/2 inch NPT output – stainless steel gland
E	3/4 inch inlet, M20 output – no gland
F	3/4 inch input, M20 output – brass nickel gland
G	3/4 inch input, M20 output – stainless steel gland

### Approvals

Code	Approval
M	Micro Motion Standard (no approval)
Z	ATEX – equipment category 2 (zone 1)

Code	Approval
L	ATEX — equipment category 3 (zone 2)
I	IECEX zone 1
3	IECEX zone 2
A	CSA Class I Div. 1 (US and Canada)
2	CSA Class I Div. 2 (US and Canada)
P	NEPSI — equipment category 2 (zone 1)
4	NEPSI — equipment category 3 (zone 2)

## Software measurement application

Code	Measurement applications
CZ	Cryogenic
FZ	Fuel Consumption
FA	Fuel Consumption with Petroleum Measurement
FC	Fuel Consumption with Custody Transfer
FB	Fuel Consumption with Petroleum Measurement and Custody Transfer

## Future option 1

Code	Future option 1
Z	Reserved for future use

## Future option 2

Code	Future option 2
Z	Reserved for future use

## Future option 3

Code	Future option 3
Z	No measurement application software

## Factory options

Code	Factory option
Z	Standard product
X	ETO product
R	Restocked product (if available)









For more information: [www.emerson.com](http://www.emerson.com)

©2021 Micro Motion, Inc. All rights reserved.

The Emerson logo is a trademark and service mark of Emerson Electric Co. Micro Motion, ELITE, ProLink, MVD and MVD Direct Connect marks are marks of one of the Emerson Automation Solutions family of companies. All other marks are property of their respective owners.

**MICRO MOTION™**

