

PD 601 DPI with RS-232 P-NET Interface

PD Series 600



PD 601 DPI is used to provide local programmable intelligence for the local cluster connected via Light-Link P-NET, and to provide an interface with MODEMS, PCs or other serial equipment, such as printers, bar code readers etc. It uses the BM 003 or BM 011 base module. PD 601 is included in the Series 600 modules and features:

- Real time clock with battery backup
- Up to 480 Kbytes RAM memory with battery backup for user data
- Up to 1 Mbytes in circuit programmable FLASH memory for user program
- Up to 2 Mbytes in circuit programmable FLASH memory for user data
- Built-in replaceable lithium battery
- LED state indicators
- Low power consumption
- Process-Pascal programmable
- Automatic checksum control of program memory after each reset

Introduction

The PD 600 series of Distributed Process Intelligence units - DPIs - has been developed as the 3rd generation of P-NET fieldbus programmable master devices, for use as distributed computing elements within highly complex as well as simple process control systems. The PD 600 series is part of a new family of standard process control devices, which can be mounted on a DIN rail.

When mounted, communication is automatically enabled through the Light-Link interface. Power is applied to all devices on the same rail by a common power bar. These facilities make mounting, connection, replacement and addition of devices very quick and easy.

Communication Interface

In the PD 601 DPI, Channel 1 is a P-NET RS-232 communication channel, primarily for communicating with MODEMs or PCs, but also with other serial devices such as bar code readers and printers.

Channel 2 is a P-NET Light-Link communication channel intended for communicating with other locally mounted P-NET devices using the optical Light-Link interface.

Programming

The PD 601 DPI is programmed in Process-Pascal, which is an extension of standard Pascal, allowing easy declaration and utilisation of P-NET variables and objects. Programs are developed and compiled on a standard PC, then downloaded directly via a P-NET interface. Program code can be downloaded to FLASH memory.

The PD 601 DPI series devices have the channels shown in the following table.

Channel		
No.	Name	Description
0	Service	Service channel
1	RS232Port	Communication channel, RS-232, P-NET mode or data mode
2	LightPort	Communication channel, Light-Link, P-NET mode or data mode
5	OpSysCh	Program channel for operating system
6	PPPProgCh	Program channel for Process-Pascal

Memory

The PD 600 DPI is available with 4 different memory versions: Small, Medium, Medium+ and Large. The amount and type of memory for each version is shown in the table.

Type	RAM *)	Program Flash	Data Flash
PD 600 S	64 Kbytes	64 Kbytes	128 KBytes
PD 600 M	480 Kbytes	512 Kbytes	1024 Mbytes
PD 600 M+	992 KBytes	512 KBytes	1024 KBytes
PD 600 L	480 Kbytes	1024 Mbytes	2048 Mbytes

*) 2Kbytes of RAM reserved for system variables.

A PD 600 DPI series device is equipped with 2 different memory types, with different characteristics. These memory types are described in the following.

The RAM memory is battery backed, and is used for static and temporary local and global Process-Pascal variables and the Process-Pascal stack. Data in RAM is preserved after a power failure, but not after a master reset of the device.

The FLASH memory can be reprogrammed 100 000 times.

The Program FLASH memory is used for Process-Pascal programs. The Data FLASH memory is used for static, global Process-Pascal variables, which are not changed very often. The FLASH memory is organized into 2 Kbytes blocks. Storing in FLASH memory will take minimum 0.5 ms pr. word. Data in FLASH is preserved, even after applying a master reset to the device. Refer to UserFLASH for further information on how to use FLASH memory for Process-Pascal variables.

Block Schematic

The following figure provides a block diagram showing the internal structure of a PD 601 DPI.

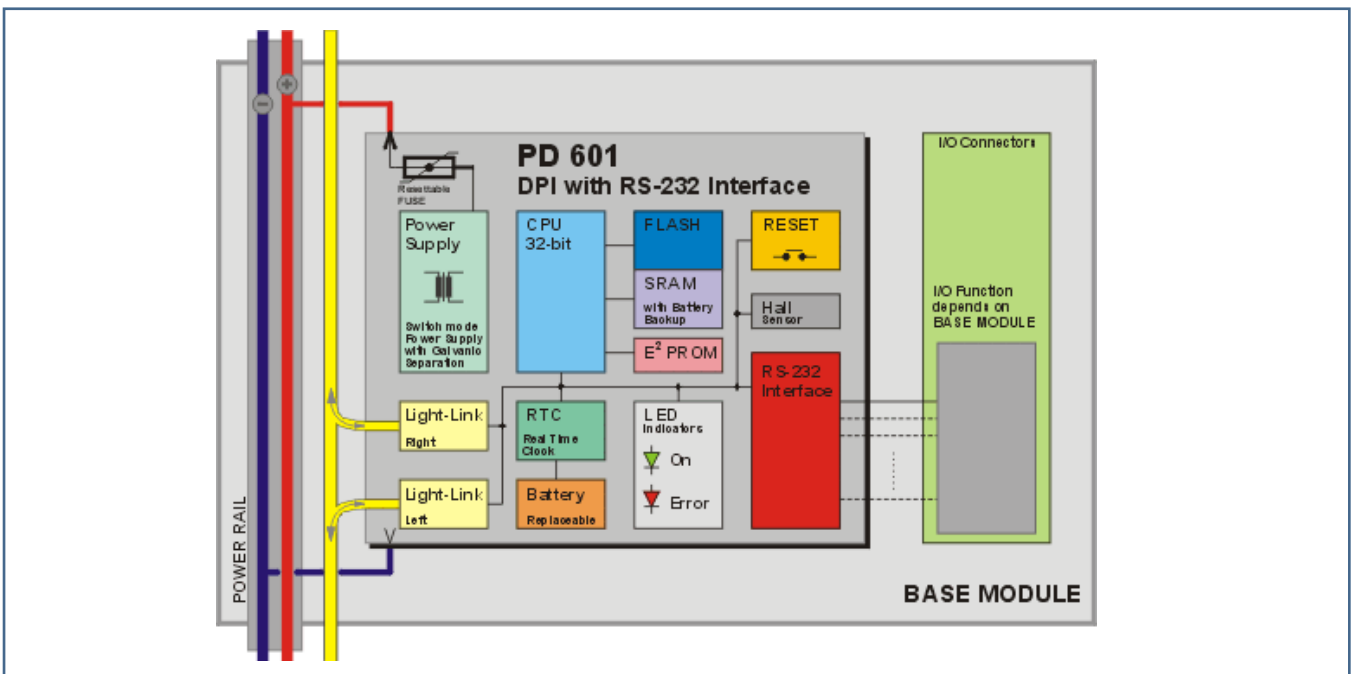

LED Indicators

A PD 601 DPI series device is equipped with 2 LED indicators, “Error” (red) and “On” (green). The state of the device is indicated by the LEDs, according to the scheme shown in the table.

Meaning	Error (Red)	On (Green)
No power	OFF	OFF
Error, not running	ON	OFF
Proces-Pascal not running	OFF	Flash, 2 Hz
Proces-Pascal running	OFF	ON
Power supply voltage too low	Flash, 0.5 Hz	OFF
Error, Proces-Pascal not running	ON	Flash. 2 Hz
Error, Proces-Pascal running	ON	ON

Power supply voltage too low occurs when MaxPowerdownTime is ≤ 0 , and the power supply voltage is below approx. 18 V.

Battery Backup

PD 601 DPI series device is equipped with a replaceable lithium battery for real time clock and RAM backup. The battery is not rechargeable. If the device is constantly powered, the lifetime

of the battery is approx. 7 years. If the device is constantly un-powered, the lifetime of the battery is approx. 3 years.

Real Time Clock

The devices are equipped with a real time clock circuit with battery backup. Max. deviation is approx. 3 minutes per month over the full temperature range, and approx. 1 minute per

month at 25 degrees Centigrade. The same circuit is used for the Process-Pascal timer system, ensuring that the real time clock and the Process-Pascal timers are synchronized.

Wiring Diagrams

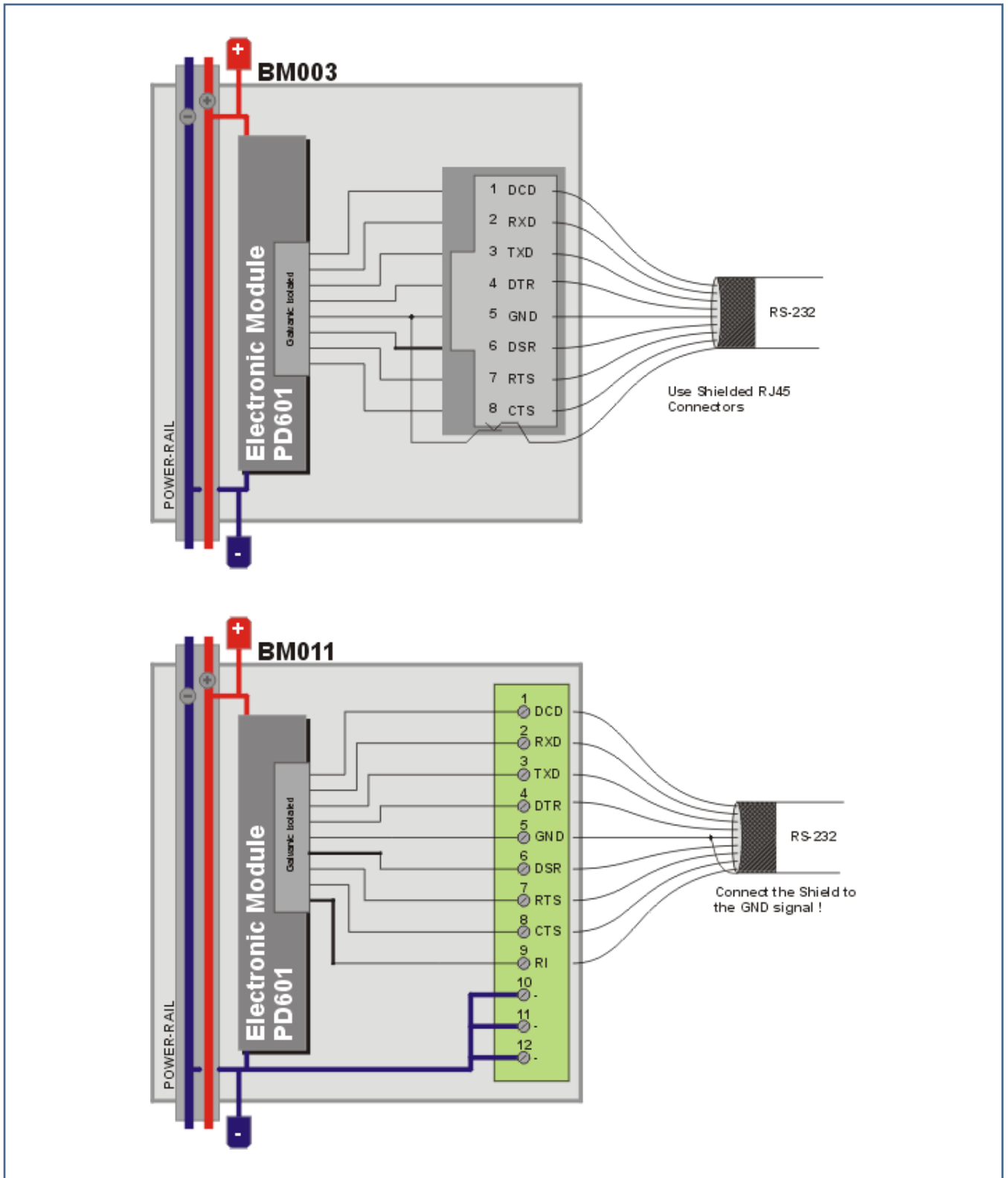

Pin	BM003 Screw terminals	BM011 RJ45	Description
1	DCD	DCD	Carrier detect
2	RXD	RXD	Receive data
3	TXD	TXD	Transmit data
4	DTR	DTR	Data terminal ready
5	GND	GND	Signal ground
6	DSR	DSR	Data set ready
7	RTS	RTS	Request to send
8	CTS	CTS	Clear to send
9	RI	*np	Ring indicator
10	-	*np	-
11	-	*np	-
12	-	*np	-

*np = Not Present

Connection Examples

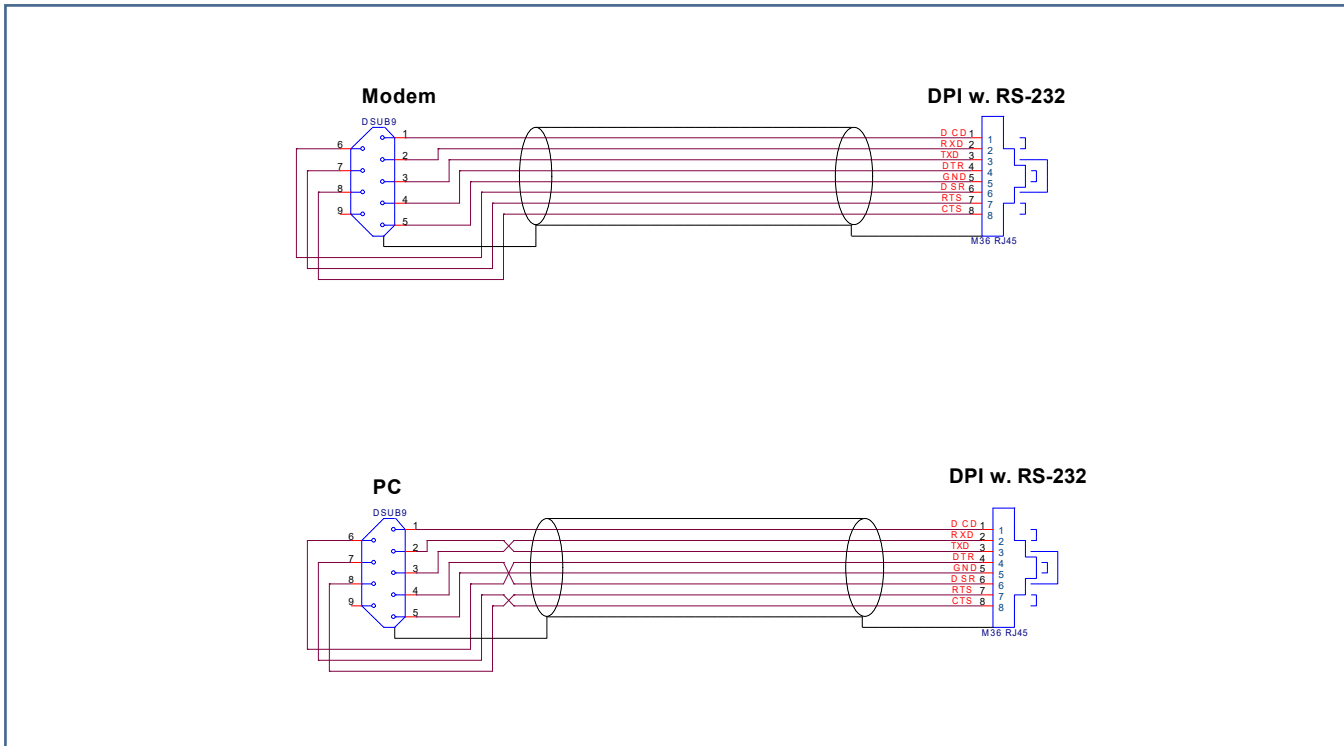

Technical Specifications

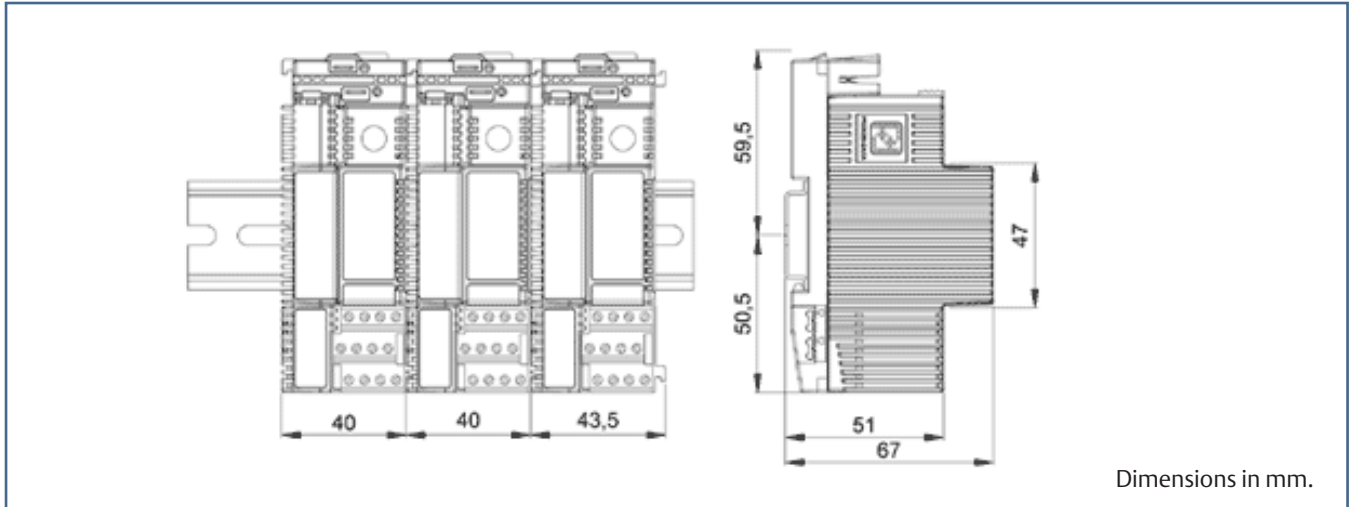

Weight	140 grams approx.
Power supply	18 to 32 VDC
Ripple	max. 5%
Power consumption @ 24VDC	
Operating	max. 50 mA
Current at power up	max. 100 mA
Operation Temperature	-25 °C to + 70 °C
Storage temperature	-40 °C to + 85 °C
Interface:	RS-232, Light-Link
Replaceable battery:	Panasonic BR 1632

Maritime Approvals

Meets the requirements of all the major international marine classification societies.

For more information see PDS for the PD Series 600 Introduction.

©2018 Emerson. All rights reserved.

The Emerson logo is a trademark and service mark of Emerson Electric Co. Damcos and the Damcos logotype are trademarks of Damcos A/S. Damcos is a member of the Emerson family of companies. All other marks are the property of their respective owners.

Emerson Automation Solutions

Damcos A/S
Aaderupvej 41
DK-4700 Naestved
T +45 5578 7200
F +45 5578 7272

www.Emerson.com/marine

The contents of this publication are presented for information purposes only, and while effort has been made to ensure their accuracy, they are not to be construed as warranties or guarantees, expressed or implied, regarding the products or services described herein or their use or applicability. Standard Terms and Conditions of Sale can be issued by contacting Damcos A/S. We reserve the right to modify or improve the designs and specifications of our products at any time without notice. Damcos A/S accepts no responsibility for any errors that may appear in this publication.

