

Rosemount™ 2501 Solids Level Switch

Rotating Paddle



- Rotation principle is unaffected by caking
- Adjustable signal output time delay
- Protected motor (friction clutch and double bearing)
- Modular design
- Temperature range from -40 to 212 °F (-40 to 110 °C)

Introduction

Measurement principles

The Rosemount 2501 Solids Level Switch uses a synchronous motor for driving a paddle (measuring vane) to rotate 360 degrees.

When the vane of the paddle is not covered by a solids medium, a spring pulls the motor and it switches a lug to the left position (Figure 1, left illustration). The signal output indicates an 'uncovered' state and the motor rotates the paddle.

When a solids medium covers the vane of the paddle, and causes the rotation to stop, the lug is switched to the right position (Figure 1, right illustration). The signal output indicates a 'covered' state due to a rising level of material, and the motor is stopped until the vane becomes uncovered.

Figure 1: Switching Lug Function

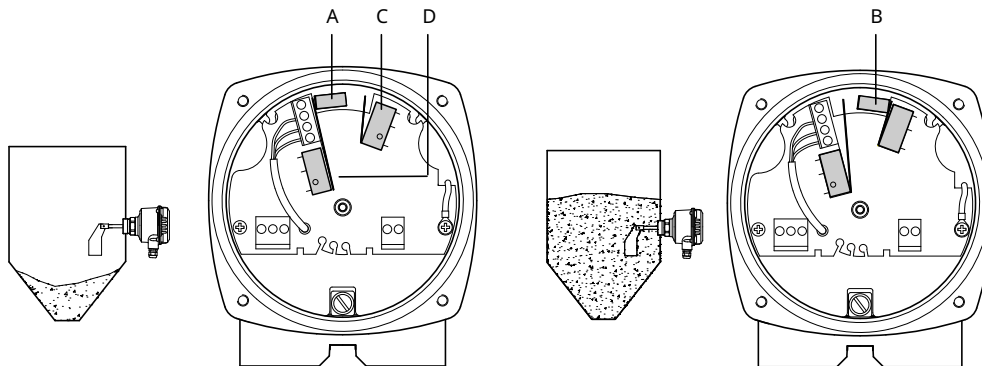

- A. Switching lug in left position ('uncovered' state)
- B. Switching lug in right position ('covered' state)
- C. Switch for stopping the motor
- D. Switch for signal output

The electrical outputs vary depending on the power supply selected when the Rosemount 2501 was ordered. See [Power supply](#) for the Power Supply option codes, and [Electrical data](#) for the electrical specifications.

Contents

Introduction.....	2
Ordering information.....	5
Spares and accessories.....	13
Specifications.....	16
Product certifications.....	22
Dimensional drawings.....	23

Key features and benefits

- Ideal for point level detection of most bulk solids materials
- Simple to install, maintenance-free measurement principle
- Reliable technology, unaffected by dust, electrostatic charge and clogging/caking
- Robust NEMA® Type 4X housing⁽¹⁾, which is suitable for use in extreme process conditions
- Designed for operation in temperature extremes of -40 °F to 2012 °F (-40 °C to 1100 °C)
- Different models to suit different sizes/types of process vessels and storage silos
- Generous space within housing with rotatable electronics, enabling easy wiring for quick installation
- Encapsulated ball bearing with shaft sealing, ideal for dusty applications
- Versatile installation in many types of vessel
 - It can be installed in vertical, horizontal, or angled positions with various extensions options available.
- Compact boom length from 2¾ in. (70 mm) is particularly suited for small process vessels

Applications

- Materials with most density types, > 0.9 lb/ft³ (15 g/l)
- Silos/vessels with limited space or large storage silos
- Environments with high levels of dust/ash present
- Overspill prevention
- High-reliability and high-safety requirements
- High-temperature applications

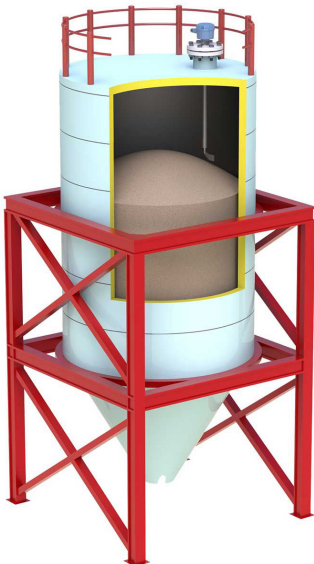

(1) The NEMA Type 4X rating requires the process connection (including extension) to be stainless steel and the process temperature to not exceed 176 °F (80 °C). In all other cases, including when a sliding sleeve is used or a Rosemount 2501 with Application Profile K, the housing is IP66/NEMA Type 4 rated.

Selection guide

Table 1: Rosemount 2501 Selection Guide

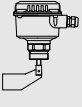
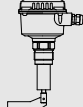
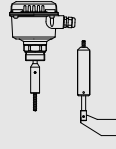
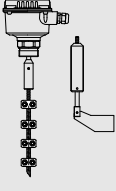
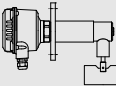
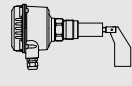
Type of installation	Model option codes					
	2501L	2501M	2501R	2501S	2501K	2501J
						
Full silo detection	★	★ ⁽¹⁾	★	★	★	★
On-demand detection	★	N/A	★ ⁽¹⁾	★ ⁽¹⁾	★	★
Empty silo detection	★	N/A	★ ⁽¹⁾	★ ⁽¹⁾	★	★
Vertical mounting	★	★	★ ⁽¹⁾	★ ⁽¹⁾	N/A	★
Angled mounting (top)	★	★ ⁽²⁾	N/A	N/A	N/A	★
Horizontal mounting	★	N/A	N/A	N/A	★	★
Angled mounting (bottom)	★	N/A	N/A	N/A	N/A	★

(1) Consider the maximum permitted mechanical traction force. See [Operating conditions](#) for the maximum supported mechanical loads.

(2) Available only with the "bearing at tube end" option (maximum of 10°).

Ordering information

Online product configurator

Many products are configurable online using our product configurator.

Select the **Configure** button or visit [Emerson.com/global](https://emerson.com/global) to start. With this tool's built-in logic and continuous validation, you can configure your products more quickly and accurately.

Specifications and options

Specification and selection of product materials, options, and/or components must be made by the purchaser of the equipment.

Model codes

Model codes contain the details related to each product. Exact model codes will vary; an example of a typical model code is shown in [Figure 2](#).

Figure 2: Model Code Example

2501 L 1 A A D 1 5 NN G A B 00000 NA D	Q4
1	2

1. Required model components (choices available on most)
2. Additional options (variety of features and functions that may be added to products)

Optimizing lead time

The starred offerings (★) represent the most common options and should be selected for the fastest delivery times. The non-starred offerings are subject to additional delivery lead time.

Rosemount 2501 Solids Level Switch ordering information



The Rosemount 2501 withstands heavy loads and extreme temperatures, and is suitable for full, demand or empty detection for all bulk media in all types of vessel. It is a simple, robust and reliable technology that is insensitive to dust, electrical charge, adhesion, extreme temperature and pressure. It is simple to install and can be mounted in a vertical, horizontal or oblique position.

[CONFIGURE >](#)
[VIEW PRODUCT >](#)

Required model components

Model

Code	Description	
2501	Rosemount Solids Level Switch - Paddle	★

Application profile

Code	Description	
L	Full or empty detection in small vessel, low mechanical resistance	★
M	Full detection in medium vessel, medium mechanical resistance	★
R	Full detection in large vessel, medium mechanical resistance (maximum 4 kN load)	★
S	Full detection in large vessel, high mechanical resistance (maximum 28 kN load)	★
J	Empty detection in medium or large vessel, low or medium mechanical resistance	★
K ⁽¹⁾	Empty detection in medium or large vessel, high mechanical resistance	★

(1) Application code K requires a 4-in./DN100 flanged process connection.

Operating temperature

Code	Description	Applications	
1	Maximum 176 °F (80 °C)	All	★
2 ⁽¹⁾	Maximum 302 °F (150 °C)	All except S	★
3 ⁽¹⁾	Maximum 482 °F (250 °C)	All except S	★
4 ⁽¹⁾	Maximum 662 °F (350 °C)	L and J only	★
5 ⁽¹⁾⁽²⁾	Maximum 1112 °F (600 °C)	All except S and K	★
6 ⁽¹⁾	Maximum 2012 °F (1100 °C)	L and M only	★

(1) Temperature-extended-shaft dimension is automatically added for this option, see [Table 7](#).

(2) Maximum overpressure is 1.45 psi (0.1 bar).

Process operating pressure

Code	Description	Temperatures	
A	Maximum 11.6 psi (0.8 bar)	All codes	★
B	Maximum 73 psi (5 bar)	1, 2, and 3	★
C	Maximum 145 psi (10 bar)	1, 2, and 3	★

Materials of construction: process connection

Code	Description	Applications	
A ⁽¹⁾⁽²⁾	Aluminum	All except S	★
D ⁽³⁾	303/304/321 Stainless steel (1.4305/1.4301/1.4541)	All codes	★
S ⁽³⁾	316L Stainless steel (1.4404)	L, M, and J	★

- (1) Available when Process Operating Temperature code 1 is selected.
- (2) Available when Process Operation Pressure code A is selected.
- (3) Not available when Process Operating Temperature code 6 is selected.

Materials of construction: extension

Code	Description	Applications	Materials (PC)	
A ⁽¹⁾⁽²⁾⁽³⁾	Aluminum	M, J, and K	A and D	★
D ⁽⁴⁾⁽⁵⁾	303/304 Stainless steel (1.4305/1.4301)	All codes	A and D	★
F ⁽⁴⁾	316L Stainless steel (1.4404)	L, J, and M	S	★

- (1) Available when Process Operation Pressure code A is selected.
- (2) Not available when Application Profile J and Process Operating Temperature codes 2 or 3 are selected.
- (3) Not available when Application Profile K and Materials of Construction: Process Connection code D is selected.
- (4) Not available when Process Operating Temperature code 6 is selected.
- (5) Not available when Application Profile K and Materials of Construction: Process Connection code A is selected.

Conduit entry/cable threads

Code	Description	
1 ⁽¹⁾	M20 x 1.5, 1 off screwed cable gland for CE, ATEX, and IECEx	★
2 ⁽²⁾	M20 x 1.5, 2 off screwed cable gland	
4 ⁽³⁾	½-in. NPT tapered, ANSI B1.20.1 (1 off conduit + 1 off Ex-d blind plug)	
6 ⁽⁴⁾	M20 x 1.5 (1 off conduit + 1 off Ex-d blind plug)	

- (1) Code 1 is for selecting a solid switch with M20 x 1.5-in threaded conduit/cable entries. The switch will be provided with 1 screwed cable gland and 1 blind plug. This option is valid with the following product certifications: CE, ATEX and IECEx, except flameproof versions.
- (2) Code 2 is for selecting a solid switch with two screwed M20 x 1.5-in. cable glands. Available for all product certification options, except flameproof versions.
- (3) Option 4 is for selecting a solid switch with NPT 1/5-in threaded conduit/cable entries. The switch will be provided with 1 conduit entry adaptor and one Ex-d rated blind plug. It is available for ordering with all product certifications.
- (4) Code 6 is for selecting a solid switch with M20 x 1.5-in. threaded conduit/cable entries. The switch will be provided with 1 conduit entry adaptor and one Ex-d rated blanking/stopping plug. This option is valid with the following product certifications: FM and CSA, except flameproof versions.

Process connection size

Code	Description	Applications	Temperatures	
1 ⁽¹⁾⁽²⁾	1-in. / 25 mm (DN25) / 25A	L	1, 2, 3	★
A ⁽¹⁾	1¼-in. / 32 mm (DN32) / 32A	All except K	1, 2, 3	★
5	1½-in. / 40 mm (DN40) / 40A	All except K	All	★
2 ⁽³⁾	2-in. / 50 mm (DN50) / 50A	All except K	All	★
3 ⁽³⁾	3-in. / 80 mm (DN80) / 80A	All except K	All	★
4	4-in. / 100 mm (DN100) / 100A	All	All	★

Code	Description	Applications	Temperatures	
B ⁽¹⁾⁽²⁾⁽⁴⁾	M30 x 1.5 mm	L only	1 only	★
C ⁽¹⁾⁽²⁾⁽⁴⁾	M32 x 1.5 mm	L only	1, 2, 3	★

- (1) Not available when Materials of Construction: Process Connection Material code S is selected.
- (2) Not available when Materials of Construction: Extension Material code A is selected.
- (3) Not available when Materials of Construction: Process Connection code A is selected.
- (4) Available when Process Operation Pressure code A is selected.

Process connection rating

Code	Description	Sizes	Materials (PC)	
AA	ASME B16.5 Class 150 flange	2, 3, and 4	All except A	★
DZ ⁽¹⁾	EN1092-1 PN6 flange	A and 4	All ⁽²⁾	★
DA	EN1092-1 PN16 flange	2 and 4	All except A	★
HA ⁽³⁾	150x150 flange, 4 off ø18 mm fixing holes	4	All except S	★
HB ⁽³⁾	150x150 flange, 4 off ø14 mm fixing holes	4	All except S	★
NN	For use with non-flange process connections	All except 3 and 4	All	★

- (1) Available when Operating Pressure codes A or B are selected.
- (2) Materials of Construction: Process Connection code A is not available when Process Connection Size code 4 is selected.
- (3) Available when Process Operation Pressure code A is selected.

Process connection type

Code	Description	Ratings	Applications	
F	Flat face flange	DZ, DA, HA, and HB	All	★
R	Raised face flange	AA	All	★
G	BSPP (G) thread	NN	All except K	★
N	NPT thread	NN	All except K	★
M ⁽¹⁾⁽²⁾	Metric thread	NN	L	★
C ⁽²⁾	Tri Clamp	NN	L, M, and J	★

- (1) Available when Process Operation Pressure code A is selected.
- (2) Not available when Process Operating Temperature codes 4, 5, or 6 is selected.

Power supply

Code	Description	
A	230 Vac 50-60 Hz, motor speed: 1 revolution per minute	
B	115 Vac 50-60 Hz, motor speed: 1 revolution per minute	
C	48 Vac 50-60 Hz, motor speed: 1 revolution per minute	
D	24 Vac 50-60 Hz, motor speed: 1 revolution per minute	
E	24 Vdc, motor speed: 1 revolution per minute	
F	24 Vdc / 22 to 230 Vac universal voltage, motor speed: 1 revolution per minute	★
R	230 Vac 50-60 Hz, motor speed: 5 revolutions per minute	
S	115 Vac 50-60 Hz, motor speed: 5 revolutions per minute	
T	48 Vac 50-60 Hz, motor speed: 5 revolutions per minute	
U	24 Vac 50-60 Hz, motor speed: 5 revolutions per minute	

Code	Description	
V	24 Vdc, motor speed: 5 revolutions per minute	
W	24 Vdc / 22 to 230 Vac universal voltage, motor speed: 5 revolutions per minute	★

Paddle length

Code	Description	Applications	
A ⁽¹⁾	Standard length 2.76-in. (70 mm)	L	★
B ⁽¹⁾	Standard length 3.93-in. (100 mm)	L	★
C ⁽¹⁾	Standard length 4.92-in. (125 mm)	K	★
D ⁽¹⁾	Standard length 5.90-in. (150 mm)	L, J, and K	★
G	Standard length 7.87-in. (200 mm)	L, J, and K	★
H	Standard length 9.84-in. (250 mm)	L, J, and K	★
J	Standard length 11.8-in. (300 mm)	L, J, and K	★
R	Rope fixings only (rope not included)	R	★
E ⁽²⁾	Extended shaft/tube, customer specified length in tenths of inches	L, M, J, and K	★
M ⁽²⁾	Extended shaft/tube, customer specified length in millimeters	L, M, J, and K	★
F ⁽²⁾	Extended rope, customer specified length in tenths of inches	R and S	★
N ⁽²⁾	Extended rope, customer specified length in millimeters	R and S	★

- (1) Not available when Operating Temperature code 4 is selected.
- (2) Please refer to [Dimensional drawings](#) for minimum and maximum length.

Specific extended paddle length

Code	Description	
00000	Factory default length (only if Paddle Length A, B, C, D, G, H, J, or R selected)	★
XXXXX	Specific customer-specified length in tenths of inches or millimeters (XXXX.X inches or XXXXX mm)	★

Product certifications

Code	Description	Conduit entries	
NA	No hazardous locations certifications	All	★
ND ⁽¹⁾	ATEX, Dust Certification (DIP)	1, 2, and 4	★
NK ⁽¹⁾	IECEX, Dust Certification (DIP)	1, 2, and 4	★
GM	Technical Regulations Customs Union (EAC), Ordinary Locations	1, 2, and 4	★
E7 ⁽¹⁾	IECEX, Flameproof / Dust Certification (DIP)	4 and 6	★
E8 ⁽¹⁾	ATEX, Flameproof / Dust Certification (DIP)	4 and 6	★
K1 ⁽¹⁾	ATEX, Increased Safety, Flameproof / Dust Certification (DIP)	1, 2, and 4	★
K7 ⁽¹⁾	IECEX, Increased Safety, Flameproof / Dust Certification (DIP)	1, 2, and 4	★
KB ⁽¹⁾	American and Canadian, Dust Certification (DIP)	4 only	★
KT ⁽¹⁾	American and Canadian, Increased Safety, Flameproof / Dust Certification (DIP)	4 only	★

Code	Description	Conduit entries	
KY ⁽¹⁾	American and Canadian, Explosion-proof / Dust Certification (DIP)	4 only	★
KZ ⁽¹⁾	American and Canadian Ordinary Location (unclassified, safe area)	4 only	★

(1) Not available when Process Temperature 4, 5, or 6 selected.

Measuring vane

Code	Description	Applications	Materials ⁽¹⁾	
A	1.02 x 3.03 inches (26 x 77 mm), boot-shaped vane	L	A and D	★
B	1.10 x 3.86 inches (28 x 98 mm), boot-shaped vane	L	All	★
C	1.38 x 4.17 inches (35 x 106 mm), boot-shaped vane	All except K	All	★
D	1.57 x 3.86 inches (40 x 98 mm), boot-shaped vane	All	All	★
K	1.57 x 3.15 inches (40 x 80 mm), rectangular notched vane	L	D and F	★
L	1.97 x 3.86 inches (50 x 98 mm), rectangular vane	All	A and D	★
M	1.97 x 5.90 inches (50 x 150 mm), rectangular vane	All	A and D	★
N	1.97 x 9.84 inches (50 x 250 mm), rectangular vane	All	A and D	★
P	3.86 x 3.86 inches (98 x 98 mm), rectangular vane	All	All	★
Q	3.86 x 5.90 inches (98 x 150 mm), rectangular vane	All	A and D	★
R	3.86 x 9.84 inches (98 x 250 mm), rectangular vane	All	A and D	★
U ⁽²⁾⁽³⁾	3.86 x 3.93 inches (98 x 100 mm), single-sided hinged vane	All	All	★
V ⁽²⁾⁽³⁾	3.86 x 7.87 inches (98 x 200 mm), double-sided hinged vane	All	All	★
W ⁽⁴⁾	3.86 x 9.84 inches (98 x 250 mm), rubber vane, up to 176 °F (80 °C)	All	A and D	★
Y	Split fin fixing for vane (vane not included)	All	A and D	★

(1) Availability of measuring vanes depending on the selected Extension Material code.

(2) Not available when Process Operating Temperature code 6 is selected.

(3) Not available when Materials of Construction: Extension code F and Operating Temperature code 4 or 5 are selected.

(4) Available when Process Operating Temperature code 1 is selected.

Additional options

Calibration data certification

Code	Description	
Q4	Certificate of functional test	★

Safety certification

Code	Description	
QS	Certificate of FMEDA Data	★

Alarm

Available when Power Supply code F or W is selected.

Code	Description	
AF	Fail-safe alarm	★

Weather protection

Code	Description	
P2	Weather protection cover	★

Welded flange

Available when Application Profile code K is selected.

Code	Description	Paddle length	
W1	Process connection flange welded to paddle tube	All except A and B	★
W2 ⁽¹⁾	Process connection flange welded to paddle tube, including reinforcing rib	All except A, B, C	★

(1) Not available when customer-specified extended lengths are selected and their material is aluminum.

Specific welded flange angle

Code	Description	
XX	Specific customer-specified angle of flange (0° to 45°) (maximum 30° with Welded Flange W2)	★

Paddle extension

Available when Application Profile code L and Extension Material code D are selected.

Code	Description	
PE1	Pendulum extension, 7.87 in. (200 mm), vertical or horizontal installation	★
PE2	Pendulum extension, 19.7 in. (500 mm), vertical installation	★
PE3	Pendulum extension, 39.4 in. (1000 mm), vertical installation	★
PE4	Rope extension, 78.7 in. (2000 mm), vertical installation	★

Sliding sleeve

Available when Application Profile code M is selected.

Code	Description	Temperatures	Pressures	
S1 ⁽¹⁾	Sliding sleeve, without over-pressure, maximum 482 °F (250 °C)	All	A	★
S2	Sliding sleeve, with over-pressure, maximum 145 psi (10 bar), maximum 482 °F (250 °C)	1, 2, 3	All	★

(1) Sliding sleeve option code S1 must not be used in hazardous (classified) areas.

Radial shaft sealing

Code	Description	Temperatures	Pressures	
T1	FPM	1	A	★
T2	PTFE	1 and 2	A	★

Alternative component material

Not available when Process Connection Size code B is selected.

Code	Description	Temperatures	Applications	
CM1	Ball bearings in stainless steel	1, 2, and 3	All except S	★

Housing heating

Available when Power Supply code F or W is selected.

Code	Description	
HH1	Heating of housing, for temperature range -4 to -40 °F (-20 to -40 °C)	★

Additional bearings

Additional bearings must be selected when Application Profile M and Materials of Construction: Extension code F are selected.

Code	Description	Applications	
BR1	Additional bearings for paddle extension tube	M	★

Extended product warranty

Code	Description	
WR5	5-year limited warranty	★

Tag plate

Code	Description	
WT	Wired tag plate	★

Spares and accessories

The specification and selection of product materials, options, or components must be made by the purchaser of the equipment. See [Material selection](#) for more information.

The starred offerings (★) represent the most common options and should be selected for best delivery. The non-starred offerings are subject to additional delivery lead time.

Table 2: Spares

Part number	Description	
02500-1000-0001	Motor: 230 Vac (50/60 Hz), 1 revolution/minute	★
02500-1000-0002	Motor: 230 Vac (50/60 Hz), 5 revolutions/minute	★
02500-1000-0003	Motor: 115 Vac (50/60 Hz), 1 revolution/minute	★
02500-1000-0004	Motor: 115 Vac (50/60 Hz), 5 revolutions/minute	★
02500-1000-0005	Motor: 48 Vac (50/60 Hz), 1 revolution/minute	★
02500-1000-0006	Motor: 48 Vac (50/60 Hz), 5 revolutions/minute	★
02500-1000-0007	Motor: 24 Vac (50/60 Hz), 1 revolution/minute	★
02500-1000-0008	Motor: 24 Vac (50/60 Hz), 5 revolutions/minute	★
02500-1000-0009	Motor: 24 Vdc, 1 revolution/minute	★
02500-1000-0010	Motor: 24 Vdc, 5 revolutions/minute	★
02500-1000-0011	Motor: 24 Vdc and 22 to 230 Vac (50/60 Hz), universal voltage, 1 revolution/minute	★
02500-1000-0012 ⁽¹⁾	Motor: 24 Vdc and 22 to 230 Vac (50/60 Hz), universal voltage, 1 revolution/minute, with fail-safe alarm	★
02500-1000-0013	Motor: 24 Vdc and 22 to 230 Vac (50/60 Hz), universal voltage, 1 revolution/minute, with housing heating (for temperatures of -20 to -40 °C)	★
02500-1000-0014 ⁽¹⁾	Motor: 24 Vdc and 22 to 230 Vac (50/60 Hz), universal voltage, 1 revolution/minute, with fail-safe alarm and housing heating (for temperatures of -20 to -40 °C)	★
02500-1000-0015	Motor: 24 Vdc and 22 to 230 Vac (50/60 Hz), universal voltage, 5 revolutions/minute,	★
02500-1000-0016 ⁽¹⁾	Motor: 24 Vdc and 22 to 230 Vac (50/60 Hz), universal voltage, 5 revolutions/minute, with fail-safe alarm	★
02500-1000-0017	Motor: 24 Vdc and 22 to 230 Vac (50/60 Hz), universal voltage, 5 revolutions/minute, with housing heating (for temperatures of -20 to -40 °C)	★
02500-1000-0018 ⁽¹⁾	Motor: 24 Vdc and 22 to 230 Vac (50/60 Hz), universal voltage, 5 revolutions/minute, with fail-safe alarm and housing heating (for temperatures of -20 to -40 °C)	★
02500-1000-0021	Paddle: 1.02 x 3.03 in. (26 x 77 mm), boot-shaped vane for M30x1.5	★
02500-1000-0022	Paddle: 1.57 x 3.86 in. (40 x 98 mm), boot-shaped vane, 304 stainless steel (1.4305)	★
02500-1000-0023	Paddle: 1.10 x 3.86 in. (28 x 98 mm), boot-shaped vane, 304 stainless steel (1.4305)	★
02500-1000-0024	Paddle: 1.38 x 4.17 in. (35 x 106 mm), boot-shaped vane, 316L stainless steel (1.4404)	★
02500-1000-0025	Paddle: 1.38 x 4.17 in. (35 x 106 mm), boot-shaped vane, 304 stainless steel (1.4305)	★
02500-1000-0026	Paddle: 1.57 x 3.86 in. (40 x 98 mm), boot-shaped vane, 316L stainless steel (1.4404)	★
02500-1000-0027	Paddle: 1.10 x 3.86 in. (28 x 98 mm), boot-shaped vane, 316L stainless steel (1.4404)	★
02500-1000-0028	Paddle: 3.86 x 9.84 in. (98 x 250 mm), rectangular vane	★
02500-1000-0029	Paddle: 3.86 x 5.90 in. (98 x 150 mm), rectangular vane	★
02500-1000-0030	Paddle: 3.86 x 3.86 in. (98 x 98 mm), rectangular vane, 304 stainless steel (1.4305)	★

Table 2: Spares (continued)

Part number	Description	
02500-1000-0031	Paddle: 1.97 x 9.84 in. (50 x 250 mm), rectangular vane	★
02500-1000-0032	Paddle: 1.97 x 5.90 in. (50 x 150 mm), rectangular vane	★
02500-1000-0033	Paddle: 1.97 x 3.86 in. (50 x 98 mm), rectangular vane	★
02500-1000-0034	Paddle: 3.86 x 3.86 in. (98 x 98 mm), rectangular vane, 316L stainless steel (1.4404)	★
02500-1000-0035	Paddle: 3.86 x 7.87 in. (98 x 200 mm), double-sided hinged vane, for 1½ and 1¼-in. BSPP, 303/304 stainless steel (1.4301/1.4305)	★
02500-1000-0036	Paddle: 3.86 x 7.87 in. (98 x 200 mm), double-sided hinged vane, for 1½ and 1¼-in. BSPP 316L stainless steel (1.4404)	★
02500-1000-0037	Paddle: 3.86 x 7.87 in. (98 x 200 mm), double-sided hinged vane, 28 mm for 1-in. BSPP and M32 hexagon nut, 303/304 stainless steel (1.4301/1.4305)	★
02500-1000-0038	Paddle: 3.86 x 3.93 in. (98 x 100 mm), single-sided hinged vane 37 mm for 1½ and 1¼-in. BSPP, 303/304 stainless steel (1.4301/1.4305)	★
02500-1000-0039	3.86 x 3.93 inches (98 x 100 mm), single-sided hinged vane, for 1½ and 1¼-in. BSPP, 316L stainless steel (1.4404)	★
02500-1000-0040	Paddle: 3.86 x 3.93 in. (98 x 100 mm), single-sided hinged vane 28 mm for 1-in. BSPP and M32 hexagon nut, 303/304 stainless steel (1.4301/1.4305)	★
02500-1000-0041	Paddle: 3.86 x 9.84 in. (98 x 250 mm), rubber vane (maximum 176 °F / 80 °C)	★
02500-1000-0042	Paddle: 1.57 x 3.15 in. (40 x 80 mm), rectangular notched vane	★
02500-1000-0044 ⁽²⁾	Rod extension by 50 mm, Ø10 mm	★
02500-1000-0045 ⁽²⁾	Rod extension by 100 mm, Ø10 mm	★
02500-1000-0046 ⁽²⁾	Rod extension by 150 mm, Ø10 mm	★
02500-1000-0047 ⁽²⁾	Rod extension by 200 mm, Ø10 mm	★
02500-1000-0048 ⁽²⁾	Pendulum extension, 19.7 in. (500 mm), vertical installation	★
02500-1000-0049 ⁽²⁾	Pendulum extension, 39.4 in. (1000 mm), vertical installation	★
02500-1000-0050 ⁽²⁾	Rope extension, 787.7 in. (2000 mm), vertical installation	★
02500-1000-0051	Single rope, Ø8 mm, with rope ends welded	★
02500-1000-0052	Fixing parts for rope extension, 787.7 in. (2000 mm)	★
02500-1000-0053 ⁽²⁾	Rope weight for full-detection in large vessels (silos), Ø30 mm rope	★
02500-1000-0054 ⁽²⁾⁽³⁾	Rope holder for full-detection in large vessels (silos), medium resistance, Ø22 mm	★
02500-1000-0055	M32 x 1.5 hexagon nut kit, aluminum, 1 off	★
02500-1000-0056	M32 x 1.5 hexagon nut kit, 303 stainless steel (1.4305), 1 off	★
02500-1000-0057	1-in. BSPP hexagon nut kit, aluminum, 1 off	★
02500-1000-0058	1-in. BSPP hexagon nut kit, 303 stainless steel (1.4305), 1 off	★
02500-1000-0059	M30 x 1.5 hexagon nut kit, aluminum, 1 off	★
02500-1000-0060	M30 x 1.5 hexagon nut kit, 303 stainless steel (1.4305), 1 off	★
02500-1000-0061	1½-in. BSPP hexagon nut kit, aluminum, 1 off	★
02500-1000-0062	1¼-in. BSPP hexagon nut kit, aluminum, 1 off	★
02500-1000-0063	1½-in. BSPP hexagon nut kit, 303 stainless steel (1.4305), 1 off	★
02500-1000-0064	1¼-in. BSPP hexagon nut kit, 303 stainless steel (1.4305), 1 off	★

Table 2: Spares (continued)

Part number	Description	
02500-1000-0065	Flush welding socket Ø69/ G 1½ in. material 1.4404	★
02500-1000-0066	Flush welding socket Ø69/ G 1½ in. material 1.4301 (304)	★
02500-1000-0067	Flush welding socket Ø69/ G 1½ in. material	★
02500-1000-0068	Weather protection for housing	★

- (1) *This module requires a sensor to detect the motor rotation, which is mounted inside the housing. Therefore it cannot be mounted into a housing where a different module was present before.*
- (2) *Delivery includes fixing parts.*
- (3) *Maximum of 4 kN load.*

Table 3: Accessories

Part number	Description	
02500-7500-0003	Mounting kit 1 for DN100 PN6 and EN1092-1 flange with ø18 mm holes, containing: 4 off M16 x 60 mm screws (304-grade stainless steel) 4 off M16 nuts 4 off washers 1 off seal (non-food grade) for up to 464 °F (240 °C)	★
02500-7500-0006	Mounting kit 2 for DN100 PN6 and EN1092-1 flange with M16 threaded holes, containing: 4 off M16 x 40 mm screws (A2-grade stainless steel) 4 off M16 washers (A2-grade stainless steel) 1 off seal (non-food grade) for up to 464 °F (240 °C)	★
02500-7500-0009	Mounting kit 3 for DN100 PN16 and EN1092-1 flange with ø18 mm holes, containing: 8 off M16 x 60 mm screws (A2-grade stainless steel) 8 off M16 nuts (A2-grade stainless steel) 8 off M16 washers (A2-grade stainless steel) 1 off seal (non-food grade) for up to 464 °F (240 °C)	★
02500-7500-0012	Mounting kit 4 for DN100 PN16 and EN1092-1 flange with M16 threaded holes, containing: 8 off M16 x 40 mm screws (A2-grade stainless steel) 8 off M16 washers (A2-grade stainless steel) 1 off seal (non-food grade) for up to 464 °F (240 °C)	★
02500-7500-0013	Mounting kit 5 for 150 x 150 mm flange with ø18 mm holes, containing: 4 off M16 x 50 mm screws (A2-grade stainless steel) 4 off M16 nuts (A2-grade stainless steel) 4 off M16 washers (A2-grade stainless steel) 1 off seal (non-food grade) for up to 464 °F (240 °C)	★
02500-7500-0014	Mounting kit 6 for 150 x 150 mm flange with M16 threaded holes, containing: 4 off M16 x 30 mm screws (A2-grade stainless steel) 4 off M16 washers (A2-grade stainless steel) 1 off seal (non-food grade) for up to 464 °F (240 °C)	★
02500-7501-0002	Flat sealing gasket 1 for 1½-in. threaded process connection. Maximum operating temperature of 482 °F (250 °C)	★
02500-7501-0003	Flat sealing gasket 2 for 1½-in. threaded process connection, includes aluminum sealing face. Maximum operating temperature of 482 °F (250 °C)	★
02500-7501-0004	Flat sealing gasket 3 for 1½-in. threaded process connection, includes 316L (1.4404) sealing face. Maximum operating temperature of 482 °F (250 °C)	★

Specifications

Mechanical data

Housing	Aluminum housing, powder coated Seal between housing and lid: NBR Seal between housing and process connection: NBR Nameplate: polyester film
Ingress Protection (IP)	IP66, NEMA Type 4X: Versions of the Rosemount 2501 with a stainless steel process connection (including extension), but do not have : <ul style="list-style-type: none"> ■ Process temperatures exceeding 302 °F (150 °C) ■ A sliding sleeve ■ Application Profile code K in the full model number IP66, NEMA Type 4: All other versions of the Rosemount 2501.
<hr/>	
Note The IP66 rating is compliant with the standard IEC/EN/NBR 60529.	
Process connection materials	Thread: 303/304 (1.4305/1.4301) or 316L (1.4404) stainless steel or aluminum Tri Clamp: 303/304 (1.4305/1.4301) or 316L (1.4404) stainless steel Flange (rectangular): 304 (1.4301) stainless steel or aluminum Flange (DN/ ANSI): 321 (1.4541) or 316L (1.4404) stainless steel; DN32 also made of aluminum
Extended length materials	Rosemount 2501L: 303/304 (1.4305/1.4301) or 316L (1.4404) Rosemount 2501M: 303/304 (1.4305/1.4301) or 316L (1.4404) or aluminum Rosemount 2501R or 2501S: 303/316 (1.4305/1.4401) stainless steel Rosemount 2501J: 303/304 (1.4305/1.4301) or 316L (1.4404) or aluminum Rosemount 2501K: 304 (1.4301) stainless steel or aluminum
Paddle shaft material	All versions: 303/304 (1.4305/1.4301) or 316L (1.4404) stainless steel
Paddle and socket materials	Boot-shaped vane: 304 (1.4301) or 316L (1.4404) stainless steel Rectangular vane: 304 (1.4301) or 316L (1.4404) stainless steel Hinged vane: 304/303/301 (1.4301/1.4305/1.4310) or 316L (1.4404) Rubber vane: 304 (1.4301)/rubber SBR
Tolerance for paddle length	±0.39 in. (±10 mm)
Bearings	Ball bearing, dust-tight
Rotary shaft seal	Materials: Graphite-based for 662 °F (350 °C) and 1112 °F (600 °C) NBR (Acrylnitril-Butadien-rubber) FPM (option code T1) PTFE (option code T2)
Friction clutch	Protects the gear unit against impacts on the paddle (measuring vane)

Speed of paddle rotation	One revolution or five revolutions per minute
Maximum noise level	50 dBA
Overall weight (approximated)	See Table 4 . All weights are approximated and without flanges (except the Rosemount 2501K) and have the smallest paddle (measuring vane).

Table 4: Overall Weights

	Version				Extension	
	176 °F (80 °C)		302/482/662/1112 °F (150/250/350/600 °C)	2012 °F (1100 °C)	Aluminum ⁽¹⁾	Stainless steel ⁽¹⁾
	Aluminum ⁽¹⁾	Stainless steel ⁽¹⁾				
2501L	3.3 lbs (1.5 kg)	4.0 lbs (1.8 kg)	2.6 lbs (1.2 kg)	6.2 lbs (2.8 kg)	(2)	(2)
2501M	3.5 lbs (1.6 kg)	4.2 lbs (1.9 kg)	2.6 lbs (1.2 kg)	6.2 lbs (2.8 kg)	2.9 lbs per 39.3 in. (1.3 kg per m)	5.9 lbs per 39.3 in. (2.7 kg per m)
2501R, 2501S	5.3 lbs (2.4 kg)	5.9 lbs (2.7 kg)	2.6 lbs (1.2 kg)	(2)	(2)	0.6 lbs per 39.3 in. (0.25 kg per m)
2501K	8.8 lbs (4.0 kg) ⁽³⁾	14.1 lbs (6.4 kg) ⁽³⁾	2.6 lbs (1.2 kg)	(2)	0.9 lbs per 3.93 in. (0.4 kg per 100 mm)	1.3 lbs per 3.93 in. (0.6 kg per 100 mm)
2501J	3.5 lbs (1.6 kg)	4.2 lbs (1.9 kg)	2.6 lbs (1.2 kg)	(2)	0.3 lbs per 3.93 in. (0.15 kg per 100 mm)	0.7 lbs per 3.93 in. (0.3 kg per 100 mm)

(1) *Material of the process connection.*

(2) *Not applicable*

(3) *Version with flange 5.9 x 5.9 x 0.47 in. (150 x 150 x 12 mm) and the 9.84-in. (250 mm) standard paddle length.*

Material selection

Emerson provides a variety of Rosemount products with various product options and configurations, including materials of construction that can be expected to perform well in a wide range of applications. The Rosemount product information presented is intended as a guide for the purchaser to make an appropriate selection for the application. It is the purchaser's sole responsibility to make a careful analysis of all process parameters (such as all chemical components, temperature, pressure, flow rate, abrasives, contaminants, etc.), when specifying product, materials, options, and components for the particular application. Emerson is not in a position to evaluate or guarantee the compatibility of the process fluid or other process parameters with the product, options, configuration, or materials of construction selected.

Electrical data

Connection terminals	Maximum 4 mm ² (AWG12)
Cable entry	M20 × 1.5 screwed cable gland ½-in. NPT conduit connection Clamping range (diameter) of the factory provided cable glands: 0.24 to 0.47 in (6 to 12 mm) for M20 x 1.5
Protection class	I
Overvoltage category	II
Pollution degree	2 (inside housing)

Power supply (ac and dc versions)	Ac version: 24, 48, 115, or 230 Vac ±10% (50/60 Hz) as ordered, maximum 4 VA External fuse: maximum 10 A, fast or slow, HBC, 250 V Dc version: 24 Vdc ±15%, maximum 2.5 W External fuse not required
Power supply (universal voltage)	24 Vdc ±15%, maximum 4 W 22 to 230 Vac (50/60 Hz) ±10%, maximum 10 VA
Signal output (ac and dc versions)	Micro switch, SPDT contact Maximum 250 Vac, 5 A, non-inductive Maximum 30 Vdc, 4 A, non-inductive External fuse: Maximum 10 A, fast or slow, HBC, 250 V
Signal and alarm output (Universal Voltage)	Relay DPDT contact Maximum 250 Vac, 5 A, non-inductive Maximum 30 Vdc, 4 A, non-inductive External fuse: Maximum 10 A, fast or slow, HBC, 250 V
Isolation	Power to signal and alarm output: 2,225 Vrms Signal output to signal output (DPDT): 2,225 Vrms
Status indication	Indicated by built-in LED (except for versions with an ac supply)

Signal output delay	Output state	Delay (Vac and Vdc)	Delay (Universal voltage)
	Covered paddle*	1.3 s	1.5 s ±0 to 20 s (adjustable)
	Uncovered paddle*	0.2 s	0.2 s +/-0..60 s (adjustable)

* After the paddle (measuring vane) has stopped rotating.

Table 5: Electronics

Power supply		SPDT ⁽¹⁾	DPDT ⁽²⁾	FSH/FSL ⁽³⁾	Output delay ⁽⁴⁾	Fail safe alarm
Ac version	24, 48, 115 or 230 Vac	★	N/A	N/A	N/A	N/A
Dc version	24 Vdc	★	N/A	N/A	N/A	N/A
Universal voltage	24 Vdc / 22..230 Vac	N/A	★	★	★	Option

- (1) *Single-Pole-Double-Throw contacts.*
- (2) *Double-Pole-Double-Throw contacts.*
- (3) *Selectable Fail Safe High or Fail Safe Low alarm output. See the Rosemount 2501 [Quick Start Guide](#) for more information.*
- (4) *Adjustable time delay for the switched outputs.*

Heating of housing When this option is selected, the motor gives out heat when temperatures are below 0 °C.

Electrical connections for the safety function

The signal output of the safety function has to be connected to terminals 4-7 on the universal voltage electronics (see [Figure 3](#)). Internally, there are two relays connected in series (terminal pairs 4-5 and 5-7).

Terminals 5, 6, 8, 9, and 10 are not part of the safety function. They can be used as documented in the Rosemount 2501 [Quick Start Guide](#), but the safety data is not valid for those terminals.

Terminals 1, 2, and PE are the same as documented in the Quick Start Guide.

Figure 3: Terminal Block Connections for Safety Function

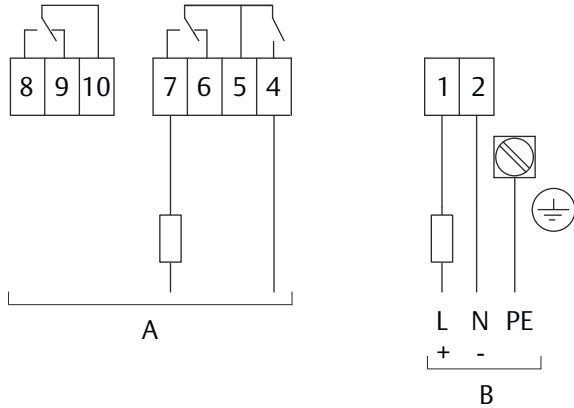

- A. Signal output connections
- B. Power supply connections

Operating conditions

Temperature

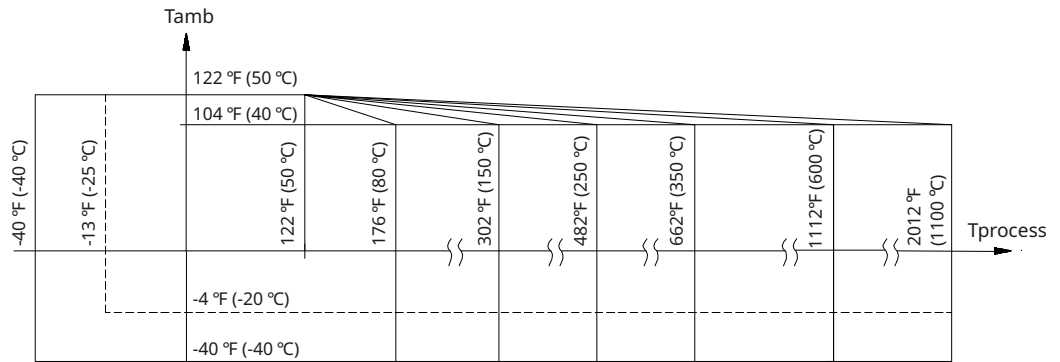

-40 °F (-40 °C) ambient and process temperature for versions with heating of housing.

662/1112 °F (350/600 °C) process temperature excludes 2501K and all other versions of the Rosemount 2521 with Ex-approvals.

2012 °F (1100 °C) process temperature is for 2501L and 2501M that do not have Ex-approvals.

Maximum process pressure

- Operating Pressure code A: -13.1 to 11.6 psi (-0.9 to +0.8 bar)
 - Operating Pressure code B: -13.1 to 73 psi (-0.9 to +5 bar)
 - Operating Pressure code C: -13.1 to 145 psi (-0.9 to +10 bar)
 - Operating Temperature codes 5 or 6: -1.5 to 1.5 psi (-0.1 to +1 bar)
- A PTFE seal is used for operating pressures exceeding 0.8 bar (11.6 psi).

Minimum powder density (sensitivity)

See [Table 6](#).

Table 6: Minimum Density Requirements and Sensitivity Settings

Paddle	Minimum density in g/l = kg/m ³ (lb/ft ³) ⁽¹⁾			
	Bulk material completely covering the vane		Bulk material is 3.93 in. (100 mm) above covered vane	
	Spring adjustment		Spring adjustment	
	Fine	Medium (factory setting)	Fine	Medium (factory setting)
Boot-shaped vane 40 x 98	200 (12)	300 (18)	100 (60)	150 (9)
Boot-shaped vane 35 x 106	200 (12)	300 (18)	100 (60)	150 (9)
Boot-shaped vane 28 x 98	300 (18)	500 (30)	150 (9)	200 (12)
Boot-shaped 26 x 77	350 (21)	560 (33)	200 (12)	250 (15)
Vane 50 x 98	300 (18)	500 (30)	150 (9)	250 (15)
Vane 50 x 150	80 (4.8)	120 (7.2)	40 (2.4)	60 (3.6)
Vane 50 x 250	30 (1.8)	50 (3)	15 (0.9)	25 (1.5)
Vane 98 x 98	100 (60)	150 (9)	50 (3)	75 (4.5)
Vane 98 x 150	30 (1.8)	50 (3)	15 (0.9)	25 (15)
Vane 98 x 250	20 (1.2)	30 (1.8)	15 (0.9)	15 (0.9)
Hinged vane 98 x 200 b=37 double-sided	70 (4.2)	100 (60)	35 (2.16)	50 (3)
Hinged vane 98 x 200 b=28 double-sided	100 (60)	150 (9)	50 (3)	75 (4.5)
Hinged vane 98 x 100 b=37 single-sided	200 (12)	300 (18)	100 (60)	150 (9)
Hinged vane 98 x 100 b=28 single-sided	300 (18)	500 (30)	150 (9)	250 (15)

(1) For versions with the **Heating of housing** option, the data in this table must be multiplied by 1.5. The reason for the multiplication factor is that a stronger spring is used and this causes high friction on the shaft seal at low temperatures.

Limitations for bulk material

Product density and mechanical vibrations in process.

Maximum permitted mechanical torque (at 104 °F, 40 °C)

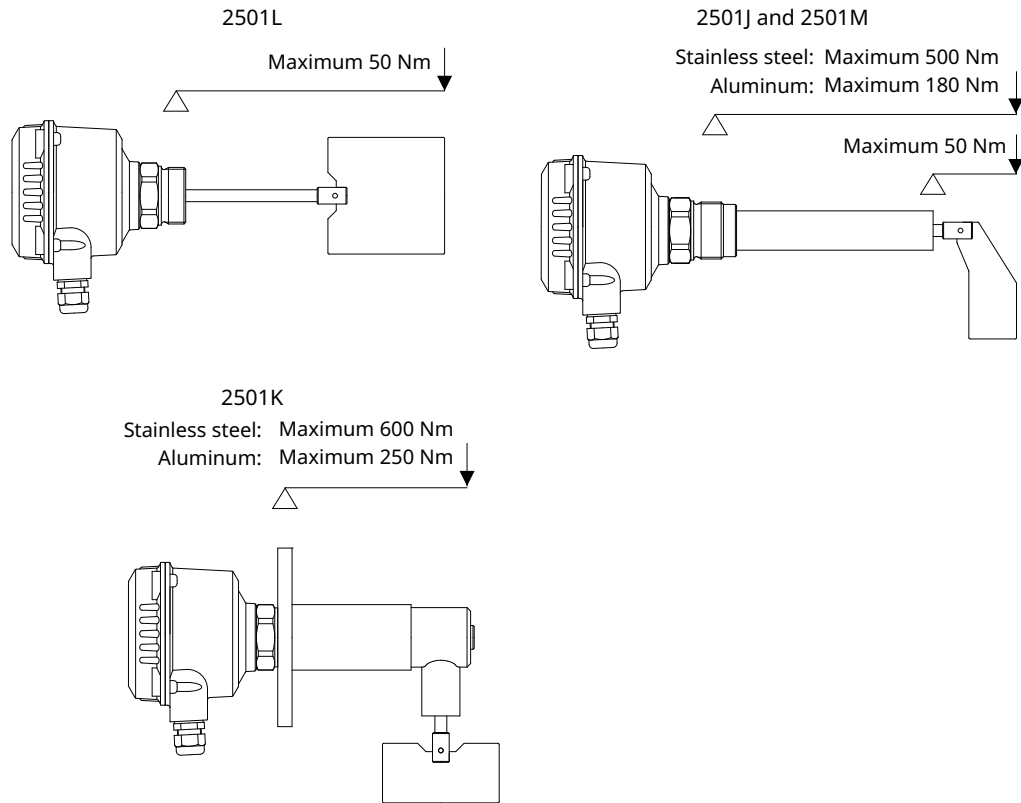

Contact Emerson for the maximum torque of a 2501 with a reinforced rib (Welded Flange option code W2).

Take protective measures, such as fitting an angled shield (reverse V shape) to the silo or selecting an extension tube option, when there are high mechanical forces.

Maximum tractive force	2501L with a pendulum shaft:	400 N (only when used as a full-silo detector)
	2501R and 2501J:	4 kN (standard rope type) 28 kN (reinforced rope type)

Ventilation Ventilation is not required.

Vibration 1.5 (m/s²)/ Hz according to EN 60068-2-64

Relative humidity 0-100%, suitable for outdoor use

Maximum altitude 6562 ft. (2000 m)

Expected product lifetime The following factors have a negative influence on the expected product lifetime:
High ambient- and process temperatures, corrosive environments, high plant vibrations, high flow rate of abrasive bulk material passing the sensor element, and high amount of measurement cycles.

Transport and storage

Transport

Refer to the instructions as stated on the transport packaging, otherwise the products may get damaged.

Transport temperature: -40 to +176 °F (-40 to +80 °C)

Transport humidity: 20 to 85%

Always inspect the received goods for any damage occurred during shipment from the factory. Notify Emerson of damaged goods as soon as possible.

Storage

Products must be stored at a dry and clean place. They must be protected from influence of corrosive environments, vibrations, and exposure to direct sunlight.

Storage temperature: -40 to +176 °F (-40 to +80 °C)

Storage humidity: 20 to 85%

Product certifications

See the Rosemount 2501 [Product Certifications](#) document for detailed information on the existing approvals and certifications.

Dimensional drawings

Figure 4: Rosemount 2501 Housing Options

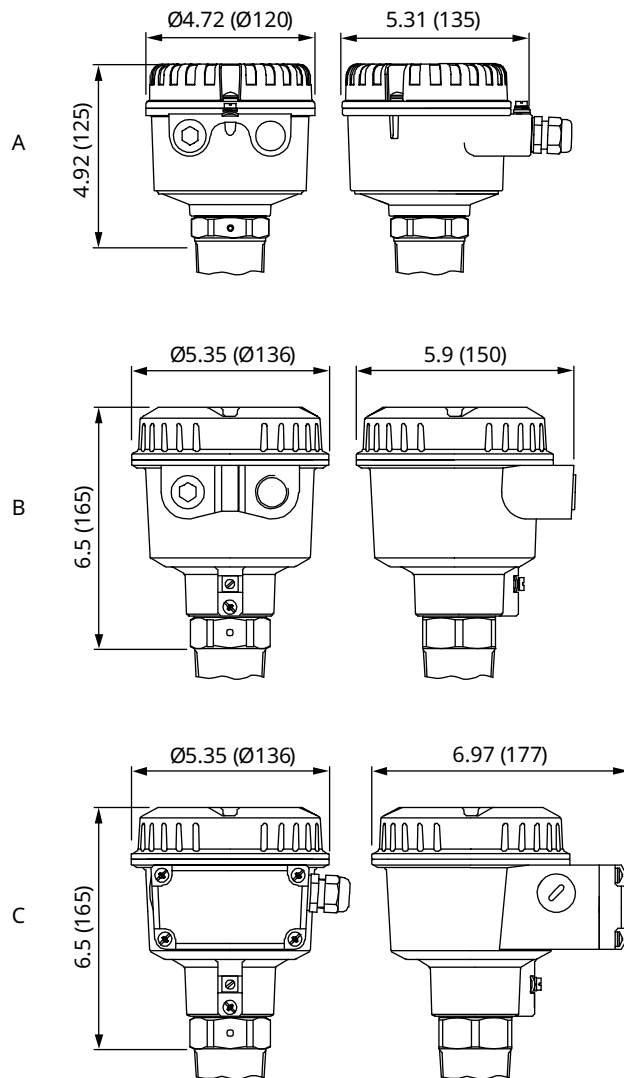

- A. Standard housing
- B. Type D flameproof/explosion-proof housing
- C. Type DE explosion-proof housing with increased safety terminal box

Dimensions are in inches (millimeters).

Figure 5: Rosemount 2501 Paddle Level Switch (Standard Length, Application Profile code L)

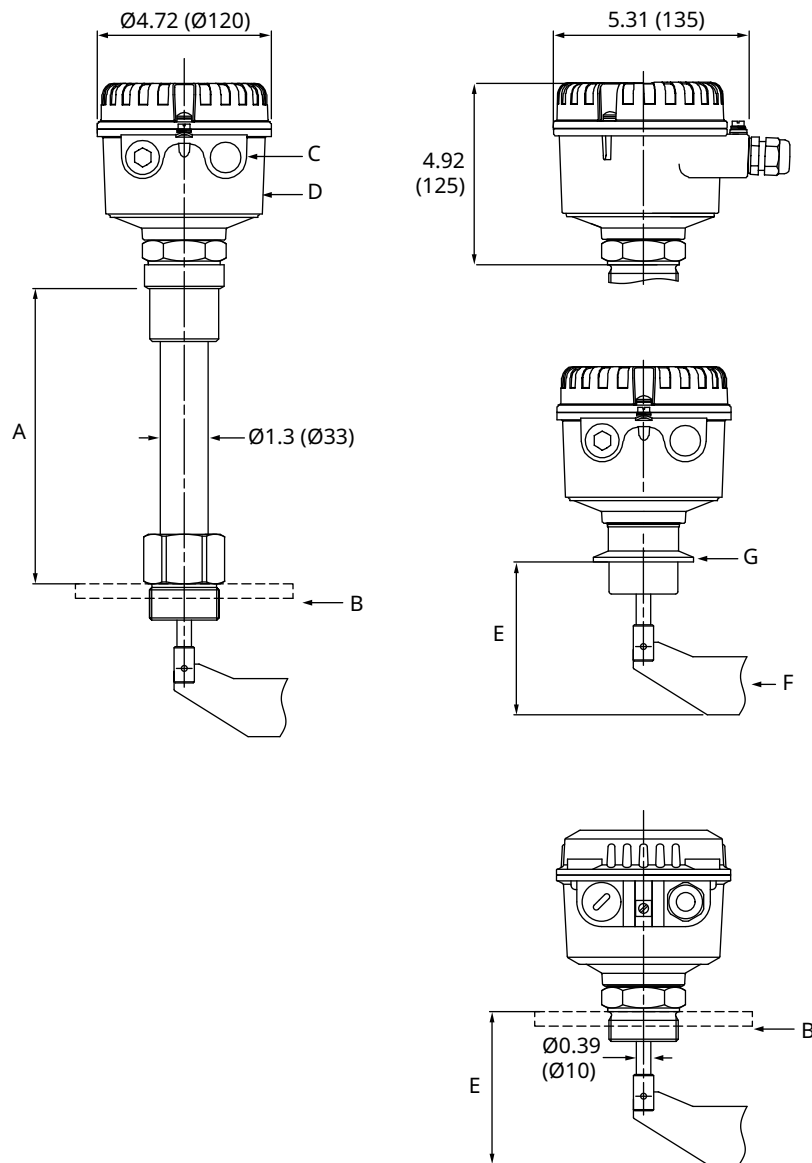

- A. Temperature-extended-shaft dimension. See [Table 7](#)
- B. Threaded or flanged process connection
- C. M20 or ½-in. NPT cable entry
- D. Aluminum standard housing. See [Figure 4](#) for dimensions of housing types D and DE.
- E. Measuring vane (paddle) dimension. See [Table 8](#)
- F. Measuring vane (paddle) options
- G. Tri Clamp process connection

Dimensions are in inches (millimeters).

Table 7: Dimension A

Process temperature	Dimension A
302 °F (150 °C)	7.87 (200)
482 °F (250 °C)	7.87 (200)
662 °F (350 °C)	11.81 (300)
1112 °F (600 °C)	15.74 (400)
2012 °F (1100 °C)	27.56 (700)

Table 8: Dimension E

Extension length	Measuring vanes allowed
2.76 (70)	Option P only
3.94 (100)	Options A, B, C, D, L, M, and N
5.91 (150)	All
7.87 (200)	All
9.84 (250)	All
11.81 (300)	All

Figure 6: Rosemount 2501 Paddle Level Switch (Extended Tube/Shaft Length, Application Profile code M)

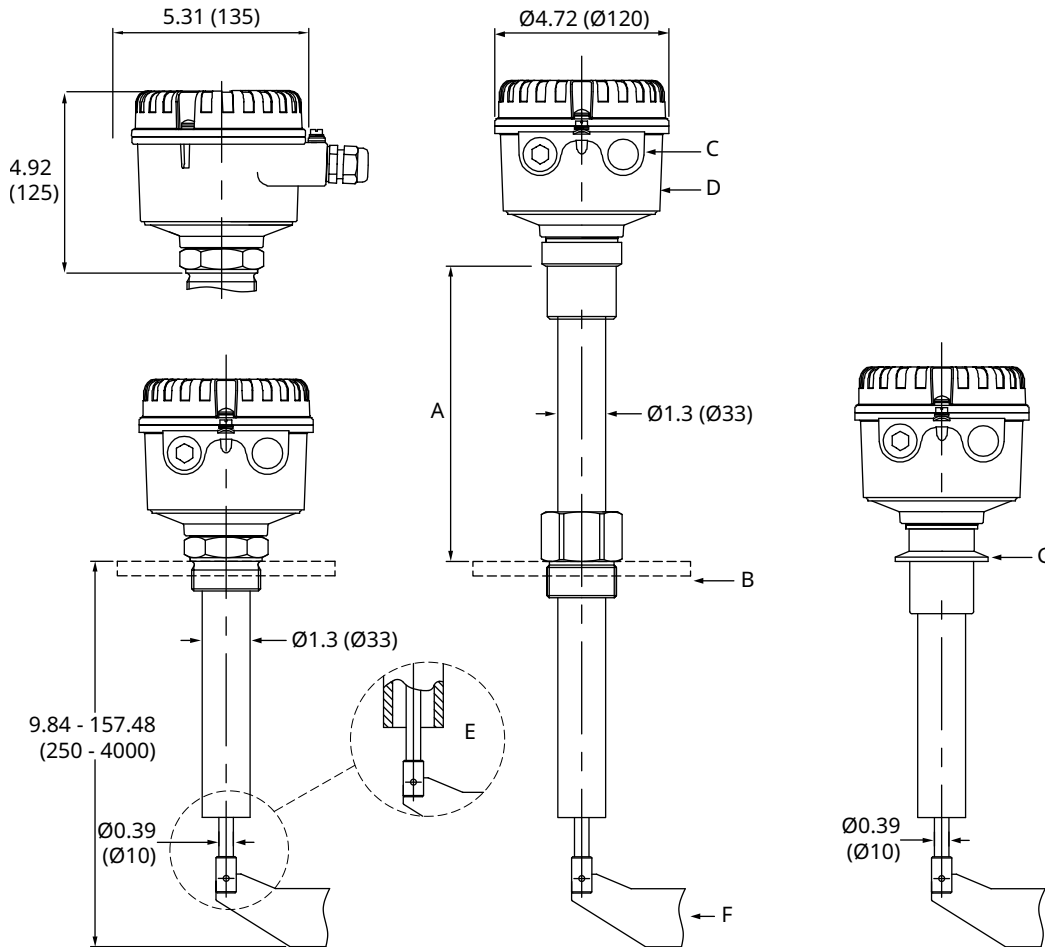

- A. Temperature-extended-shaft dimension. See [Table 7](#)
- B. Threaded or flanged process connection
- C. M20 or ½-in. NPT cable entry
- D. Aluminum standard housing. See [Figure 4](#) for dimensions of housing types D and DE.
- E. Without sealing and bearing at the tube end
- F. Measuring vane (paddle) options
- G. 2-in. Tri Clamp process connection (maximum 482 °F / 250 °C)

Dimensions are in inches (millimeters).

Figure 7: Rosemount 2501 Paddle Level Switch (Rope-Extended Length, Application Profile codes R and S)

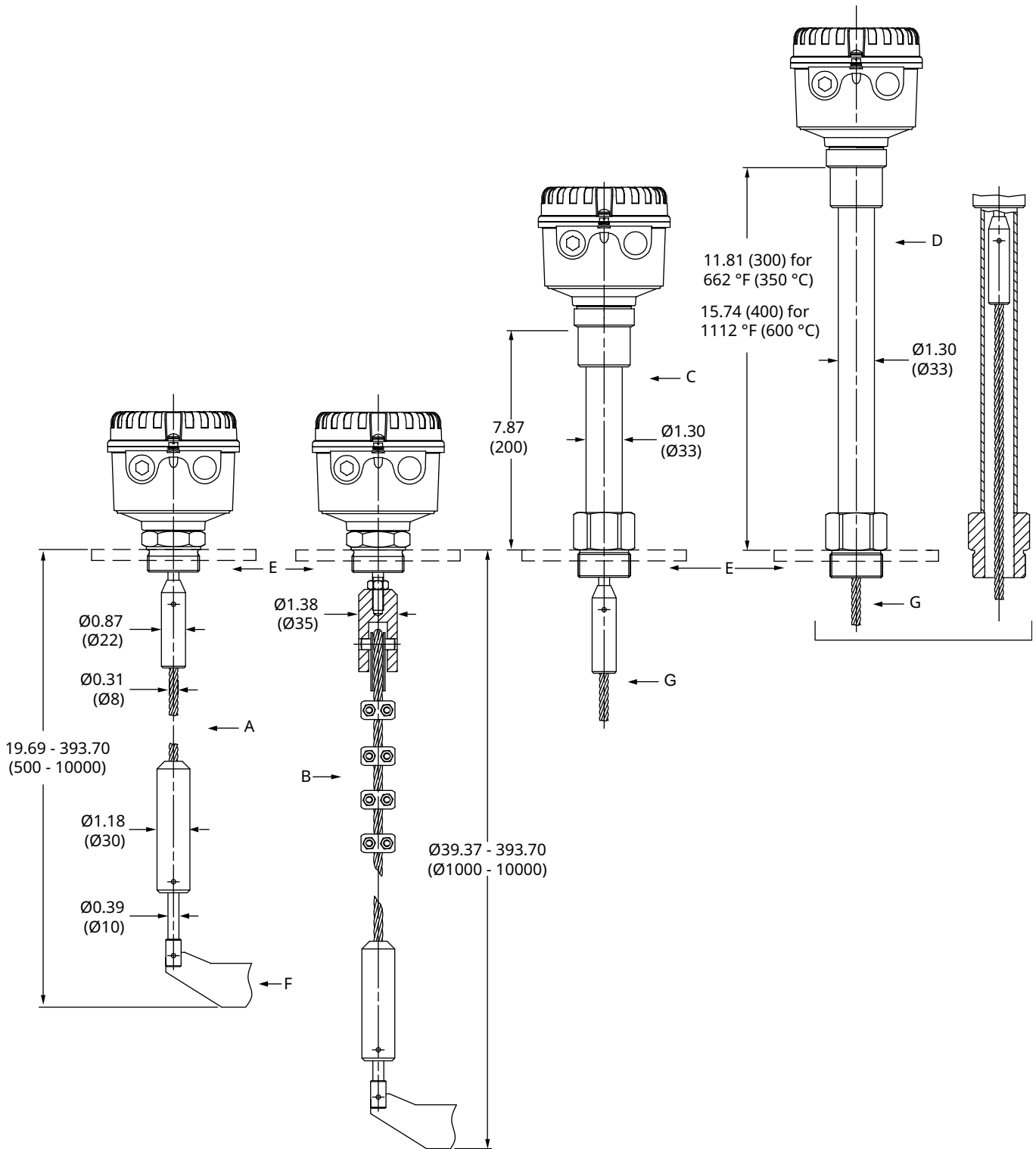

- A. Standard type of rope-extended paddle (maximum 4 kN load)
- B. Reinforced type of rope-extended paddle (maximum 28 kN load)
- C. Temperature-extended shaft for $302/482^\circ\text{F}$ ($150/250^\circ\text{C}$)

- D. Temperature-extended shaft for 662/1,112 °F (350/600 °C)
- E. Threaded or flanged process connection
- F. Measuring vane (paddle) options
- G. Rope-extended paddle

Dimensions are in inches (millimeters).

Figure 8: Rosemount 2501 Paddle Level Switch (Application Profile code K)

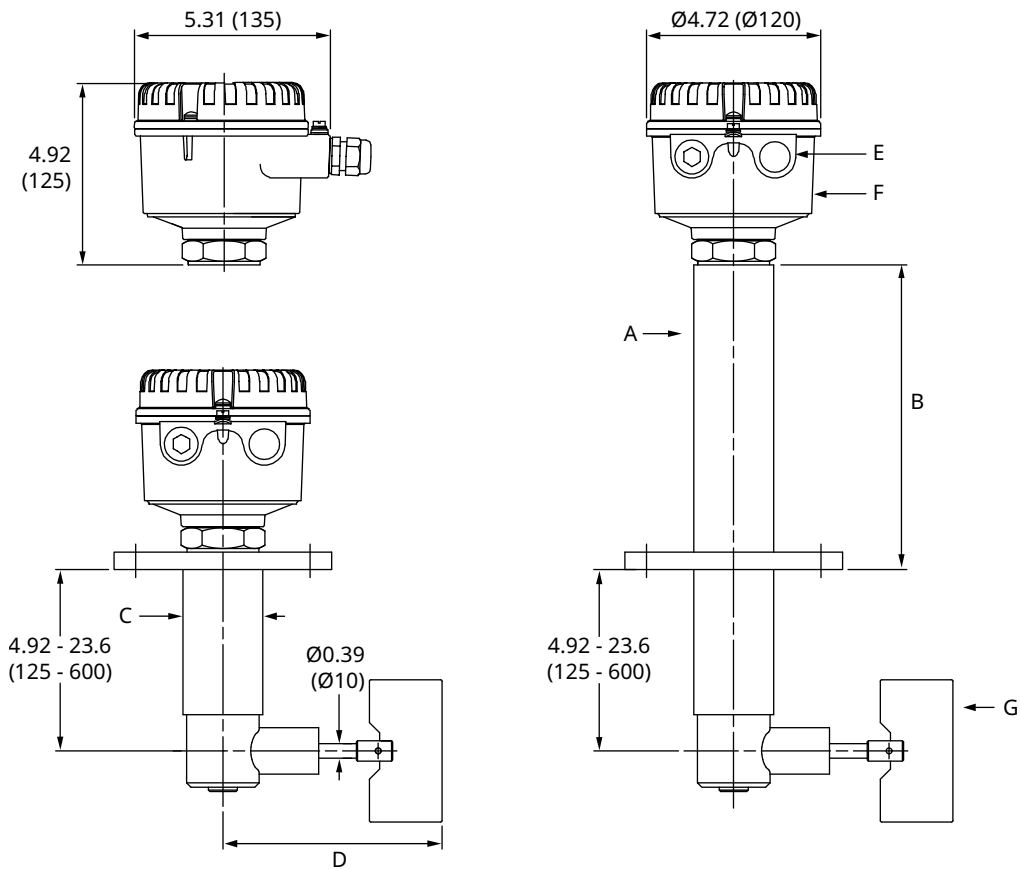

- A. Temperature extended shaft
- B. Dimension B. See [Table 9](#)
- C. Dimension C. See [Table 10](#)
- D. Dimension D. See [Table 11](#)
- E. M20 or 1/2-in. NPT cable entry
- F. Aluminum standard housing. See [Figure 4](#) for dimensions of housing types D and DE.
- G. Measuring vane (paddle) options

Dimensions are in inches (millimeters).

Table 9: Dimensions B

Process temperature	Dimension B
176 °F (80 °C), 11.6 psi (0.8 bar)	0.39 in. (10 mm)
176 °F (80 °C), 73 or 145 psi (5 or 10 bar)	2.95 in. (75 mm)

Table 9: Dimensions B (continued)

Process temperature	Dimension B
302 or 482 °F (150 or 250 °C), 11.6, 73 or 145 psi (0.8, 5, or 10 bar)	8.27 in. (210 mm)

Table 10: Dimensions C

Material	Dimension C
Steel	2.17 in. (55 mm)
Aluminum	2.36 in. (60 mm)

Table 11: Dimensions D

Measuring vane (paddle)	D dimension
1.97 in. x .. in. (50 mm x .. mm)	5.47 in. (139 mm)
3.86 in. x ..in. (98 mm x .. mm)	7.36 in. (187 mm)

Figure 9: Rosemount 2501 Paddle Level Switch (Application Profile code J)

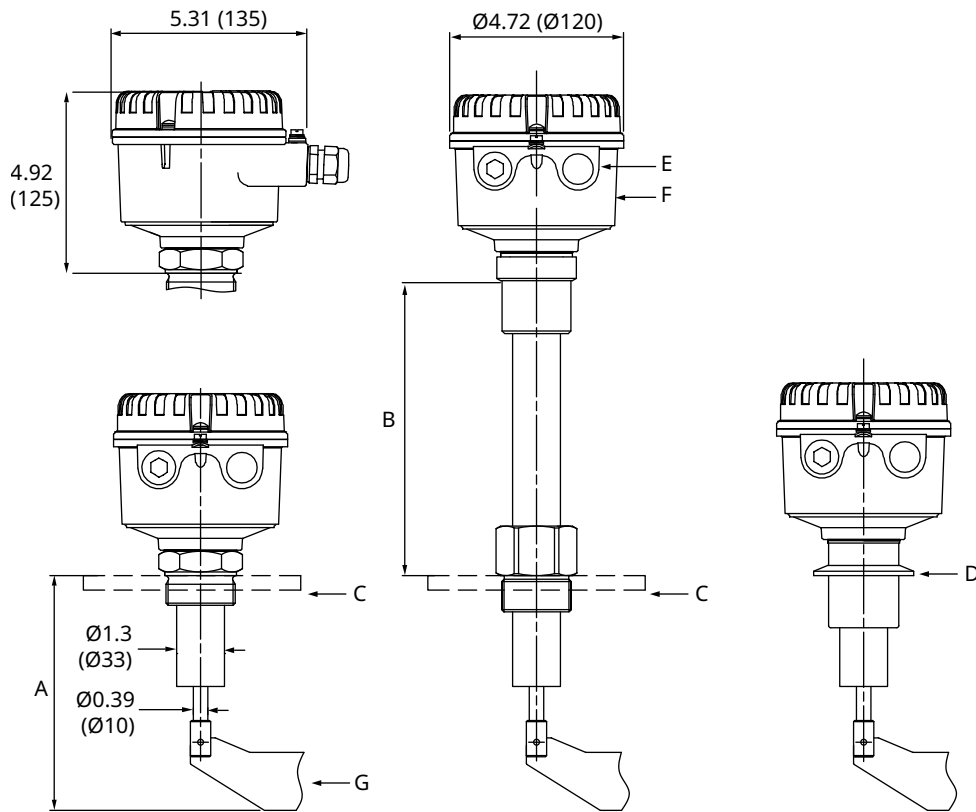

- A. Dimension A. See [Table 13](#)
- B. Dimension B. See [Table 12](#)
- C. Threaded or flanged process connection
- D. Tri Clamp process connection
- E. M20 or 1/2-in. NPT cable entry
- F. Aluminum standard housing. See [Figure 4](#) for dimensions of housing types D and DE.
- G. Measuring vane (paddle) options

Dimensions are in inches (millimeters).

Table 12: Dimension A

Process temperature	A dimension
302 °F (150 °C)	7.87 in. (200 mm)
482 °F (250 °C)	7.87 in. (200 mm)
662 °F (350 °C)	11.81 in. (300 mm)
1112 °F (600 °C)	15.74 in. (400 mm)

Table 13: Dimension E

Extension length	Measuring vanes allowed
5.91 (150)	Options C, D, L, M, and N
7.87 (200)	All

Table 13: Dimension E (continued)

Extension length	Measuring vanes allowed
9.84 (250)	All
11.81 (300)	All

Other lengths: Minimum 13.78 (350), maximum 23.62 (600)

Table 14: Paddles (measuring vanes)

Double-sided vanes have twice the measuring rate, compared to single-sided vanes.

<p>Figure 10: Rectangular Vane - Codes L, M, N, P, Q, R</p>	<p>Figure 11: Rectangular Notched Vane 40 x 80 mm - Code K</p>
<p>Figure 12: Boot-shaped Vane 40 x 98 mm - Code D</p>	<p>Figure 13: Hinged Vane 98 x 200 mm, Double-sided - Code V</p>
<p>Figure 14: Boot-shaped Vane 35 x 106 mm - Code C</p>	<p>Figure 15: Boot-shaped Vane 98 x 100 mm, Single-sided - Code U</p>

Table 14: Paddles (measuring vanes) (continued)

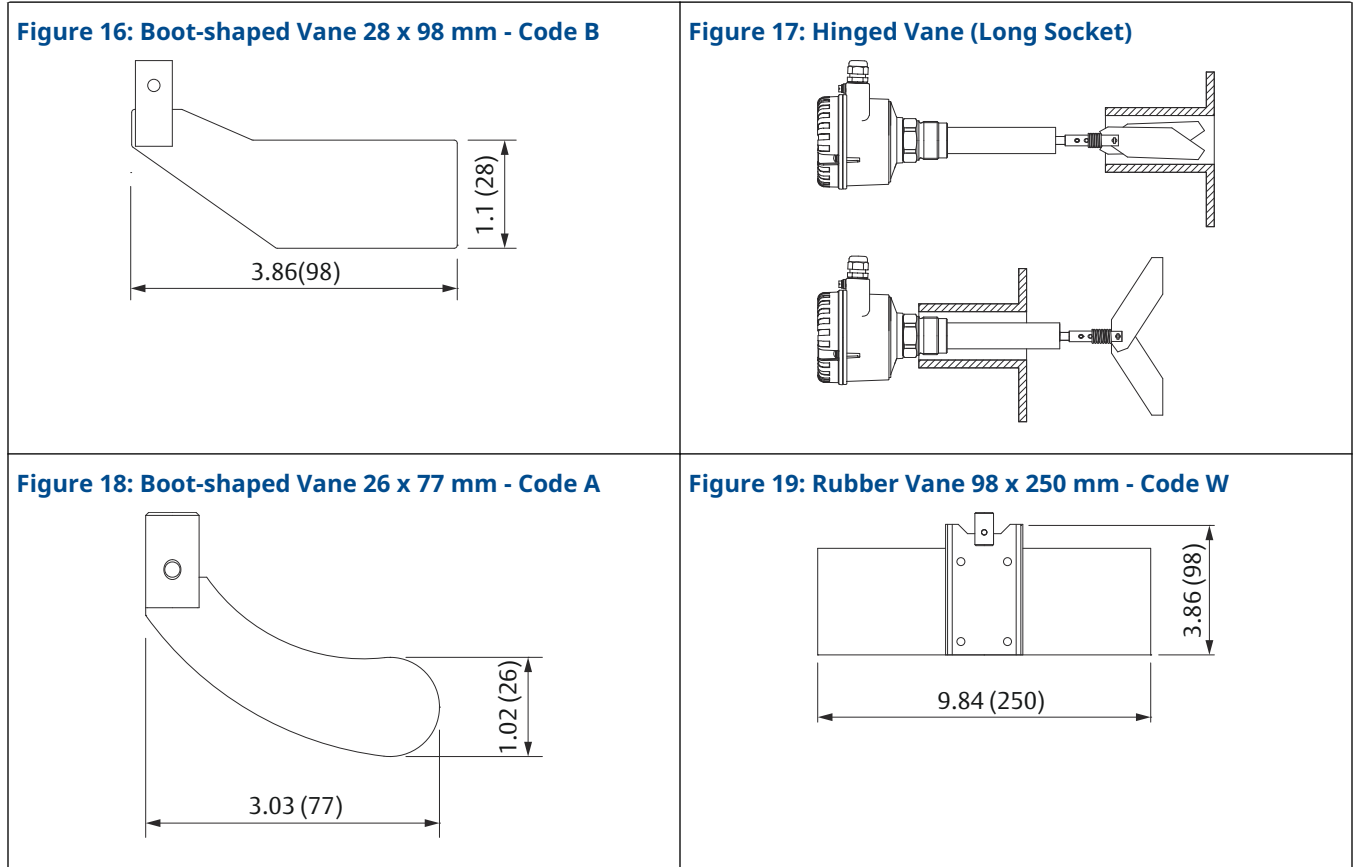

Dimensions are in inches (millimeters).

See [Table 15](#) for A and B dimensions.

Table 15: Measuring Vane Dimensions A and B

Code	Type	Dimension A	Dimension B
L	Rectangular	1.97 (50)	3.86 (98)
M	Rectangular	1.97 (50)	5.9 (150)
N	Rectangular	1.97 (50)	9.84 (250)
P	Rectangular	3.86 (98)	3.86 (98)
Q	Rectangular	3.86 (98)	5.90 (150)
R	Rectangular	3.86 (98)	9.84 (250)
U	Hinged, single-sided		1.46 (37) for 1½ in. or 1¼ in.
V	Hinged, double-sided		1.1 (28) for 1 in. or M32x1.5

Sliding sleeve

Sliding sleeve can be used to adjust the position of the paddle. When using the sliding sleeve the total length of the level switch remains unchanged, make sure that there is sufficient space to allow for these adjustments.

Figure 20: Sliding Sleeve

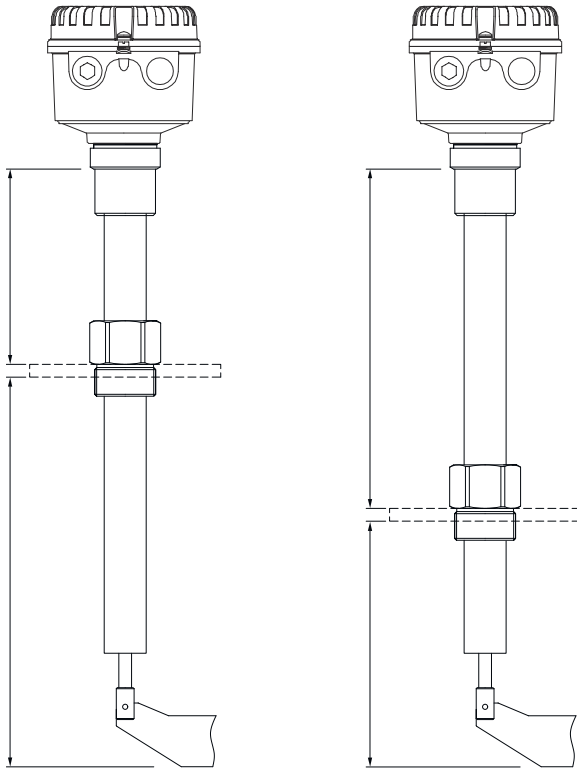

Welded flange

Figure 21: Process connection flange welded to paddle tube

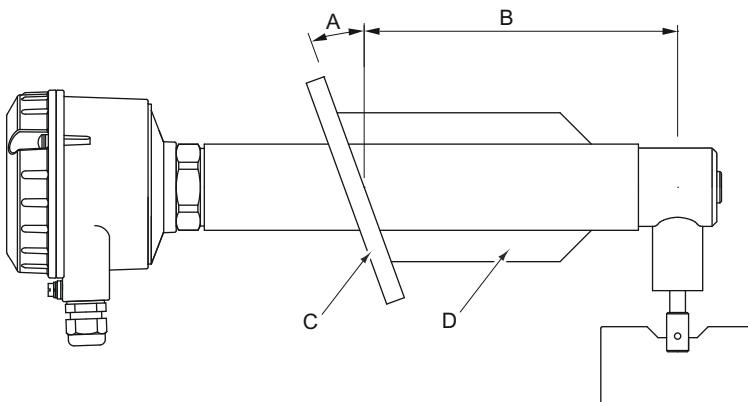

- A. Specific customer-specified angle of flange (0° to 45°), (maximum 30° with Welded flange option code W2)
- B. Extension
- C. Extension and flange welded
- D. Reinforced rib

For more information: [Emerson.com/global](https://emerson.com/global)

©2024 Emerson. All rights reserved.

Emerson Terms and Conditions of Sale are available upon request. The Emerson logo is a trademark and service mark of Emerson Electric Co. Rosemount is a mark of one of the Emerson family of companies. All other marks are the property of their respective owners.