

Rosemount™ 4390 Series of Corrosion and Erosion Wireless Transmitters



Rosemount 4390 Series of Corrosion and Erosion Wireless Transmitters provide continuous, accurate, and highly sensitive real-time corrosion and erosion monitoring data, enabling maximum performance through process optimization and eliminate the need of costly walkdowns. The transmitter contributes to superior corrosion and erosion management data by using top-range technology to provide improved data processing, flexible data management solutions, and a friendly user interface.

The Rosemount 4390 Series of Corrosion and Erosion Wireless Transmitters have the following features:

- Delivers best in class resolution and measurement sensitivity
- Operates with Electrical Resistance (ER), Linear Polarization Resistance (LPR), Galvanic, Multiple-Element Sand/Erosion, or Combined probes
- Reads monitoring probes from most common vendors
- Provides up to 20 meters of probe cable that offer flexible, convenient positioning for maintenance and radio signals
- Provides flexibility in data formats and data management

Operating principle

Rosemount 4390 Series of Corrosion and Erosion Wireless Transmitters is an Emerson™ wireless product and uses the same radio and power modules as other Emerson wireless products. The corrosion and erosion transmitter communicates through standard wireless Gateways. The gateways interface with existing host systems using industry standard protocols including OPC, Modbus® TCP/IP, and Modbus RTU.

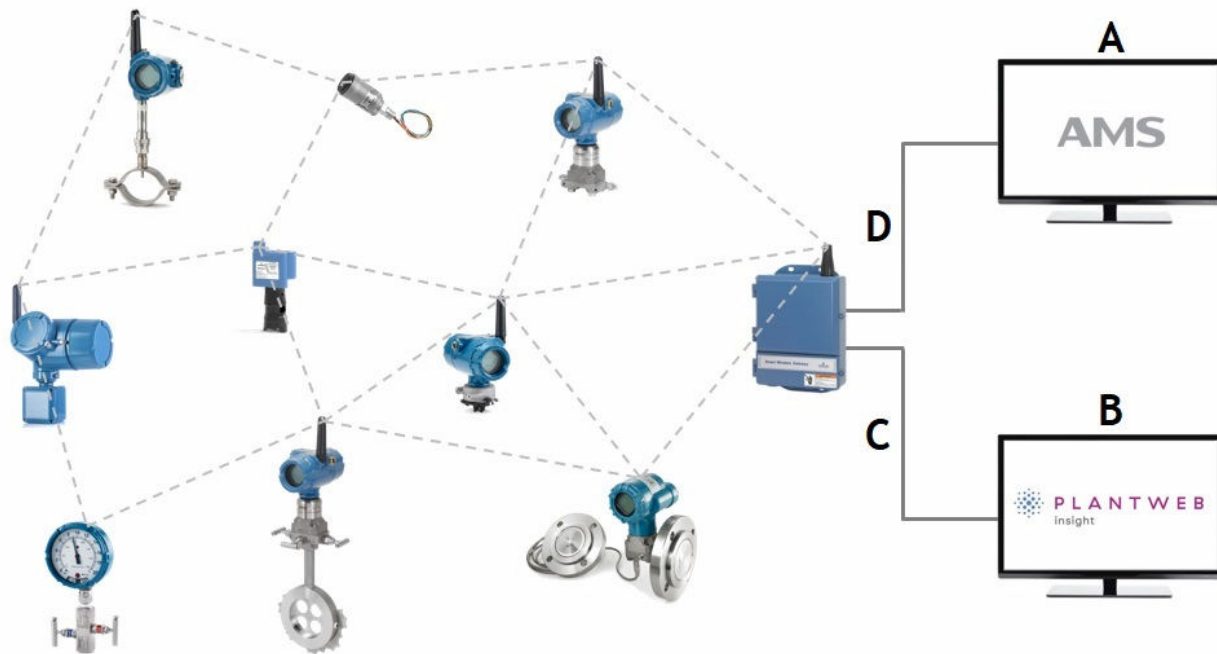

- A. AMS Suite
- B. Plantweb™ Insight In-line Corrosion Application
- C. Modbus/OPC
- D. HART® data

Reliable wireless architecture

- Standard IEEE 802.15.4 radios
- 2.4 GHz ISM band sliced into 15 radio-channels
- Allows for time-synchronized channel hopping in order to avoid interference from other radios, Wi-Fi®, and EMC sources, thereby increasing reliability
- Delivers high reliability in challenging radio environments using Direct Sequence Spread Spectrum (DSSS) technology

High accuracy data monitoring

The transmitter can provide fast and reliable corrosion monitoring, identifying within 10 to 20 nanometers of metal loss, based on frequent measurements when using an ER probe.

System flexibility

- The wireless transmitter allows up to a 20 meter cable between probe and transmitter
 - The transmitter can be installed conveniently for battery replacement and other maintenance without a need for scaffolding for access
 - The transmitter should be installed where it is most beneficial for wireless signal routing, avoiding shadows where radio communication would be difficult
- Reads corrosion and erosion probes from most common manufacturers

Data Management

- Data format (calculated metal loss data, corrosion and erosion rates, or probe raw data) is user selectable from the HART terminal, or from the Emerson Asset Management System (AMS)
- The corrosion wireless transmitter can be seamlessly integrated with Plantweb Insight Inline Corrosion Application and Fieldwatch™ software suite
- Calculated metal loss can be transmitted directly to and displayed in Emerson AMS system
- Calculated metal loss can be transmitted to any historian or control system for data management

Other benefits

The integrated Emerson wireless product, can be combined with other Emerson wireless products in an integrated network, using same gateway for data communication

Product specifications

Item	Description
General	For connection with intrusive corrosion and erosion probes
Connection	Connected to a probe through a probe cable (maximum 65 ft (20 m))
Humidity limits	5 - 95% relative humidity
Measurement intervals	Sand, Electrical Resistance (ER) and galvanic probes can be measured as fast as 1-minute intervals, while Linear Polarization Resistance (LPR) probes can be measured as fast as 4-minute intervals
Communication	WirelessHart® 2.4 GHz DSSS (Discrete Sequential Spread Spectrum)
Instrument resolution	24 bit
ER probe	Actual accuracy 10-100 ppm of probe element thickness, depending on probe type and environmental conditions
LPR probe	Accuracy of 100 ppm for the resistance measured on the LPR port
Sand probe	Actual accuracy 10-100 ppm of probe element thickness, depending on probe type and environmental conditions
Operating pressure	-40 °F (-40 °C) to 158 °F (70 °C)
Battery capacity	To simulate the power module life span, refer to the calculator here: Power Module Life Estimator .
Power module	Black power module, type 701PBKKF; Replaceable, non-rechargeable; Intrinsically safe Lithium-Thionyl Chloride power module pack with PBT/PC enclosure. 7.2 V
Housing	Painted aluminum, IP 66
Weight	Painted aluminum: 5kg

Certification

Europe

Telecommunications compliance

All wireless devices require certification to ensure they adhere to regulations regarding the use of the RF spectrum. Nearly every country requires this type of product certification. Emerson is working with governmental agencies around the world to supply fully compliant products and remove the risk of violating country directives or laws governing wireless device usage.

Ex approvals for hazardous areas

Intrinsically safe parameters

Table 1: Intrinsically safe parameters

ER port	U _o = 5.9V; I _o = 1.697A; P _o = 0.83W; IIC: C _o = 82nF; L _o = 12.34μH; L _o /R _o = 14.20 μH/Ω IIB: C _o = 9μF; L _o = 49.36μH; L _o /R _o = 56.80 μH/Ω
LPR port	U _o = 5.9V; I _o = 0.235A; P _o = 0.309W; IIC: C _o = 210nF; L _o = 0.64mH; L _o /R _o = 102 μH/Ω IIB: C _o = 9μF; L _o = 2.56mH; L _o /R _o = 408 μH/Ω
Galvanic port	U _o = 5.9V; I _o = 0,180 A; P _o = 0.244 W; IIC: C _o = 230nF; L _o = 1.09mH; L _o /R _o = 133 μH/Ω IIB: C _o = 9μF; L _o = 4.36mH; L _o /R _o = 532 μH/Ω
HART service port	U _o = 5.9V; I _o = 12.64mA; P _o = 18.65mW; C _o = 420nF; L _o = 223mH; L _o /R _o = 1.9mH/Ω; U _i = 1.9V; I _i = 32μA; P _i = 61 μW; C _i = 1μF; L _i = Negligible
<p>Note The transmitter can only be powered with 701PBKKF SmartPower Black Power Module with P/N 00753-9920-0001 only. The whole electronics are isolated from the enclosure (boards, battery, antenna, etc.). It should withstand a 500V test between the metal body and circuits.</p>	
T _{amb} = -40 °F (-40 °C) to 158 °F (70 °C)	

I1 - ATEX Intrinsic Safety

Table 2: I1 - ATEX Intrinsic Safety

Certificate	Presafe 20 ATEX 79679X
Standards	EN IEC 60079-0:2018 and EN 60079-11:2012
Markings	II 1 G Ex ia IIC T4 Ga, -40°C ≤ Ta ≤ 70°C
Specific conditions for safe use (X):	<ul style="list-style-type: none"> - The external connections must be connected to intrinsically safe circuits with parameters complying with the parameters specified in this certificate and the manufacturer’s installation manual. - This product 4390 Series Corrosion and Erosion Wireless transmitters is approved with following battery pack model 701PBKKF SmartPower Module - Black with P/N 00753-9920-0001. - The plastic enclosure of the battery pack model mentioned above may constitute a potential electrostatic ignition risk and caution should be used when being handled. - The plastic antenna and the painted enclosure may present a potential electrostatic ignition hazard and must not be rubbed or cleaned with a dry cloth. - Instrument enclosure made of 100% aluminum is used, impact and friction must be avoided due to ignition hazard. - The probe outputs only connected to simple apparatus (passive circuits). All other terminals will only be connected to IS rated apparatus complying with the IS input parameters. - Separate IECEx / ATEX certified IP66 cable gland or plugs must be used.

I7 - IECEx Intrinsic Safety

Table 3: I7 - IECEx Intrinsic Safety

Certificate	IECEX PRE 20.0096X
Standards	IEC 60079-0:2017 Edition 7.0 and IEC 60079-11: 2011 Edition 6.0
Markings	Ex ia IIC T4 Ga, -40°C ≤ Ta ≤ 70°C
Specific conditions for safe use (X):	<ul style="list-style-type: none"> - The external connections must be connected to intrinsically safe circuits with parameters complying with the parameters specified in this certificate and the manufacturer’s installation manual. - This product 4390 Series Corrosion and Erosion Wireless transmitters is approved with following battery pack model 701PBKKF SmartPower Module - Black with P/N 00753-9920-0001. - The plastic enclosure of the battery pack model mentioned above may constitute a potential electrostatic ignition risk and caution should be used when being handled. - The plastic antenna and the painted enclosure may present a potential electrostatic ignition hazard and must not be rubbed or cleaned with a dry cloth. - Instrument enclosure made of 100% aluminum is used, impact and friction must be avoided due to ignition hazard. - The probe outputs only connected to simple apparatus (passive circuits). All other terminals will only be connected to IS rated apparatus complying with the IS input parameters. - Separate IECEx / ATEX certified IP66 cable gland or plugs must be used.

Transmitter dimensions

Figure 1: Dimensions for the Rosemount 4390 Transmitter

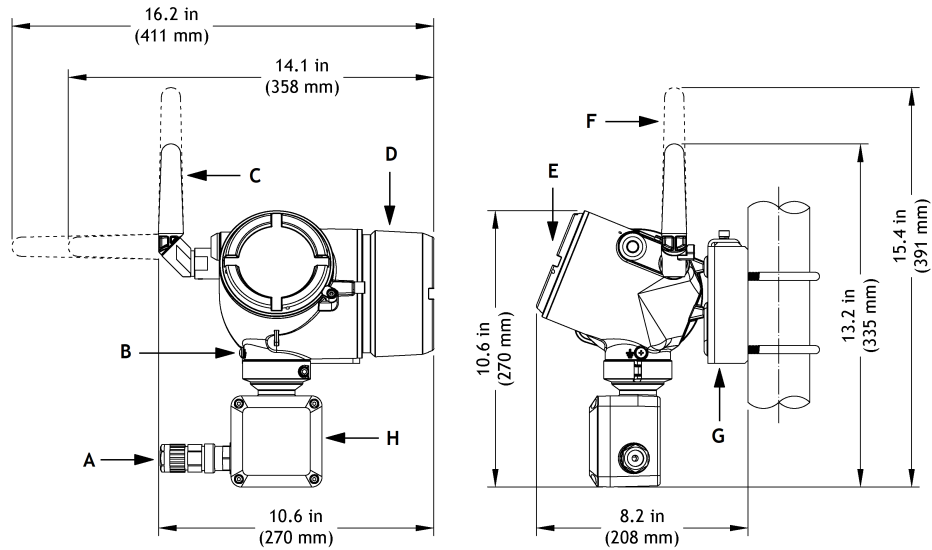

- A. Probe cable gland (optional)
- B. Grounding lug
- C. 2.4 GHz external antenna
- D. Power module extended cover
- E. Electronics cover
- F. 2.4 GHz extended range, external antenna
- G. Mounting bracket kit
- H. Junction box for probe connection

Rosemount 4390 Series of Corrosion and Erosion Wireless Transmitters ordering information

Specifications and options

See the Specifications and options section for more details on each configuration. Specification and selection of product materials, options, or components must be made by the purchaser of the equipment. See the Material selection section for more information.

Model codes

Model codes contain the details related to each product. Exact model codes will vary; an example of a typical model code is shown just below.

Mode code example

XXX X XXX X X XX XXX XXX XX
 1 2

1. Required model components (choices available on most)
2. Additional options (variety of features and functions that may be added to products)

Product description

Code	Product Description
439	4390 Series Wireless Corrosion and Erosion Transmitter

Measurement

Code	Description
1	Corrosion
2	Erosion

Probe connection / mounting

Code	Description
R	Remote mounting with probe cable, bracket for wall or pipe mounting, and hardware for 2 in pipe mount

Enclosure material

Code	Description
A	Aluminum

Display

Code	Description
00	No display

Communication protocol

Code	Description
WA3	User configurable update rate, 2.4 GHz DSSS, IEC 62591 (<i>WirelessHART</i>)

Antenna options

Code	Description
WK1	External antenna, adapter for black power module (I.S. Power module sold separately)
WM1	Extended range, external antenna, adapter for black power module (I.S. Power module sold separately)

Approvals

Code	Description
I1	ATEX intrinsically safe
I7	IECEx intrinsically safe

Probe cable gland

Code	Description
G0	No gland - M20x1.5
G1	No gland - ½ in - 14 in NPT
G2	No gland - ¾ in - 14 in NPT
M3	Metric; nickel-plated brass
M4	Metric; stainless steel
N3	NPT; nickel-plated brass
N4	NPT; stainless steel

Probe cable size range

Code	Description
0 ⁽¹⁾	Not applicable
1 ⁽²⁾	Standard multicable (5.5 mm to 12 mm OD / 3.5 mm to 8.1 mm ID) Applicable for corrosion and erosion
2 ⁽²⁾⁽³⁾	Armored cable BFOU(c) (12.5 mm to 20.5 mm OD / 8.4 mm to 14.3 mm ID) Applicable for corrosion
3 ⁽²⁾⁽⁴⁾	Armored cable BFOU(c) (16.9 mm to 26 mm OD / 11.1 mm to 19.7 mm ID) Applicable for erosion

(1) Available only with probe cable gland option G0, G1, and G2 no gland.

(2) Not available with probe cable gland option G0, G1, and G2 no gland.

(3) Not available with measurement option 2.

(4) Not available with measurement option 1.

Tag plates

Code	Description
ZZ	Customer information not required
TG	Instrument tagging - customer information required (max. 30 characters)

Configuration

Code	Description
C0	Standard factory configuration
C1	Factory custom configuration, descriptor, message fields, and wireless parameters

Transmitter option 1

Code	Description
Z	Standard

Factory option

Code	Description
Z	Standard product

For more information: www.emerson.com

©2021 Emerson. All rights reserved.

Emerson Terms and Conditions of Sale are available upon request. The Emerson logo is a trademark and service mark of Emerson Electric Co. Rosemount is a mark of one of the Emerson family of companies. All other marks are the property of their respective owners.

ROSEMOUNT™

