

Rosemount OTG 51

Overfill Alarm Radar Gauge, Still Pipe Antenna



The Rosemount OTG 51 Tank Radar Gauge for LNG applications is a high level and overfill alarm gauge used in independent safety applications in liquefied gas tanks and is part of the Rosemount Overfill Control System (OFC). It is an intrinsically safe tank radar intended to be mounted on ships deck. The radar transmission is guided through a still pipe measuring the surface of the liquid. Using our reliable method, the signals are digitally processed to achieve an accurate reading of the distance to the surface.

The technology allows two radar measurements to be done separately and independently from each other in one and the same gauge.

- The most accurate and reliable level measurement from the pioneers in radar level gauging and LNG CTMS
- The OTG 51 is an integrated part of the Rosemount Overfill Control system (OFC)
- Connects with the OCA 51 overfill alarm cabinet and its alarm panel
- Ideal solution for reliable independent high level and overfill measurements on liquefied gas tanks
- Dual channel measurement with one Tank Radar Gauge and one still pipe utilizing two independent radars
- Automatic self test and functionality surveillance
- Meets requirements for all major marine classification societies

Description

The Rosemount OTG 51 Overfill Alarm Radar Gauge is suited for installation on LNG and LPG tanks. The unit is equipped with a cone antenna and measures the level of the liquefied gas in the still pipe. The still pipe acts as a waveguide, guiding the radar waves to the liquid surface and back up to the electronics.

The intrinsically safe gauge comprises the antenna with a sensor that transmit, and receive, radar signals. The gauge can be equipped with up to two modules, one module per level alarm channel. The electrical parts in each module are separated (galvanically isolated) from each other. Each module processes the signals independently from each other and hence the high level and overfill alarm functions are integrated in one single unit, yet functionally separated. This intelligent and autonomous gauge sends the processed data to the Rosemount OCA 51 Overfill Alarm Cabinet to be displayed on the alarm panel.

Still Pipe and in-tank Installation

The complete assembly consists of the OTG 51 and a still pipe segment with an ventilation hole. The still pipe is supported by support brackets to an internal structure, e.g. pipe tower platforms, or alternatively with fingersprings in a protective pipe.

Tank Installation Overview

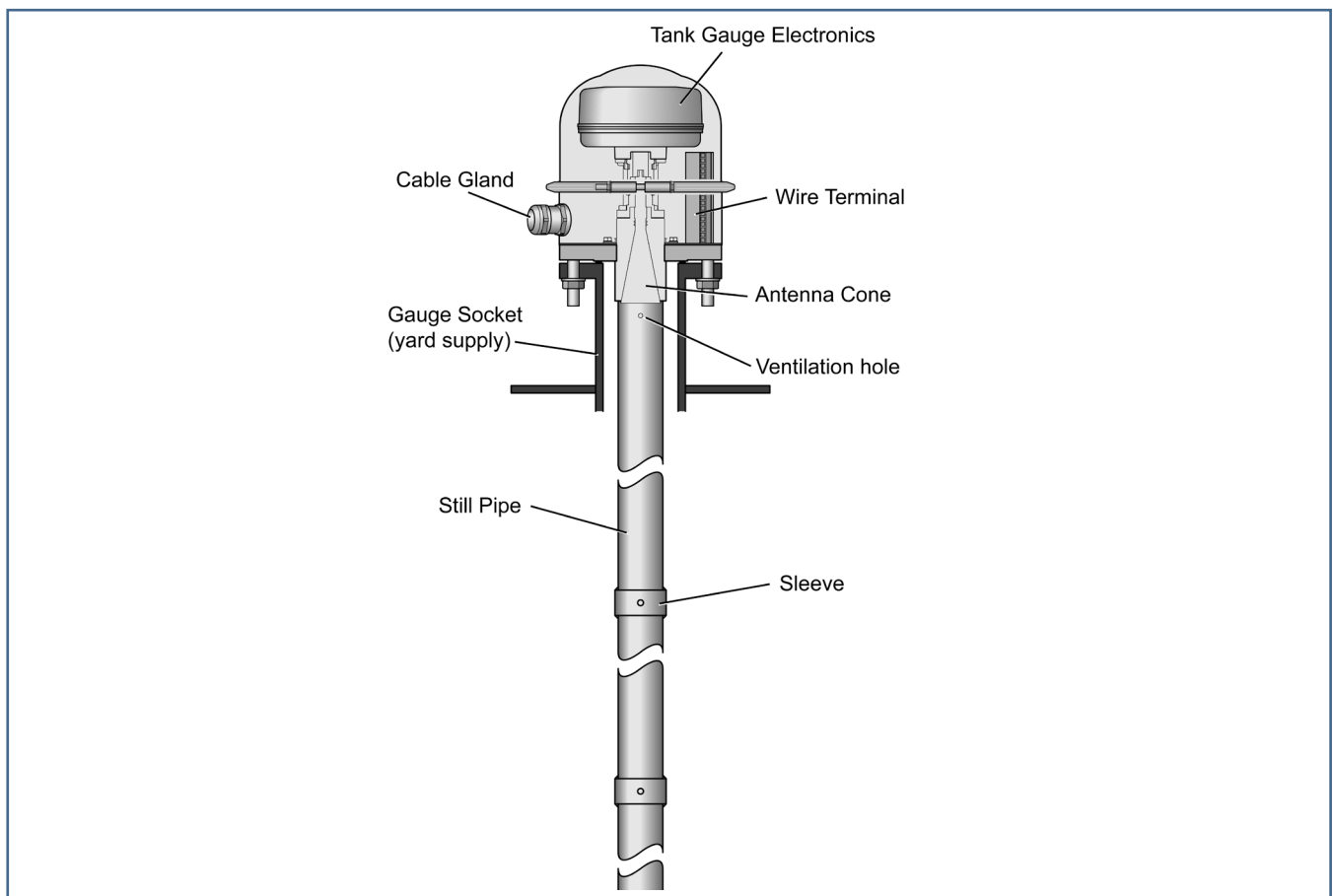

Technical Specification

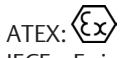
Product Name	
General Specification	
Antenna type	Cone antenna with Still Pipe
Product range	Liquefied gases
Measuring range	max. 15 m to alarm point
Instrument accuracy	± 3 mm
Number of radar channels	One or two
FMCW centre frequency	10 GHz
Operating temperature, tank	-170 °C to +100 °C
Operating pressure, tank	-0.2 to 8 Bar
Electrical Specification	
Cable to control room	Up to 2 cables, 2x2 twisted wire cable with common shield to each measurement channel
Number of cable inlets	1 to 2
Cable diameters	6 to 21mm
Field bus	Proprietary intrinsically safe
Microwave output power	<1 mW
Mechanical Specification	
Weight	20 kg (gauge socket excluded)
Material facing tank atmosphere	Stainless steel 304L, PTFE
Material facing deck	Stainless steel 316L
Process connection	ANSI 3" (standard) ANSI 6", DN80, JIS5 (optional)
Still pipe dimension	2"
Environment Specification	
Ingress protection	IP56
Ambient temperature	-40 to +70 °C
Approvals	
Marine type approvals	ABS, BV, CCS, DNV-GL, KR, LR, NK, RINA
Explosion protection	Intrinsically safe:  ATEX: II 1G Ex ia IIC T4 Ga IECEx: Ex ia IIC T4 Ga

Dimensional Drawings

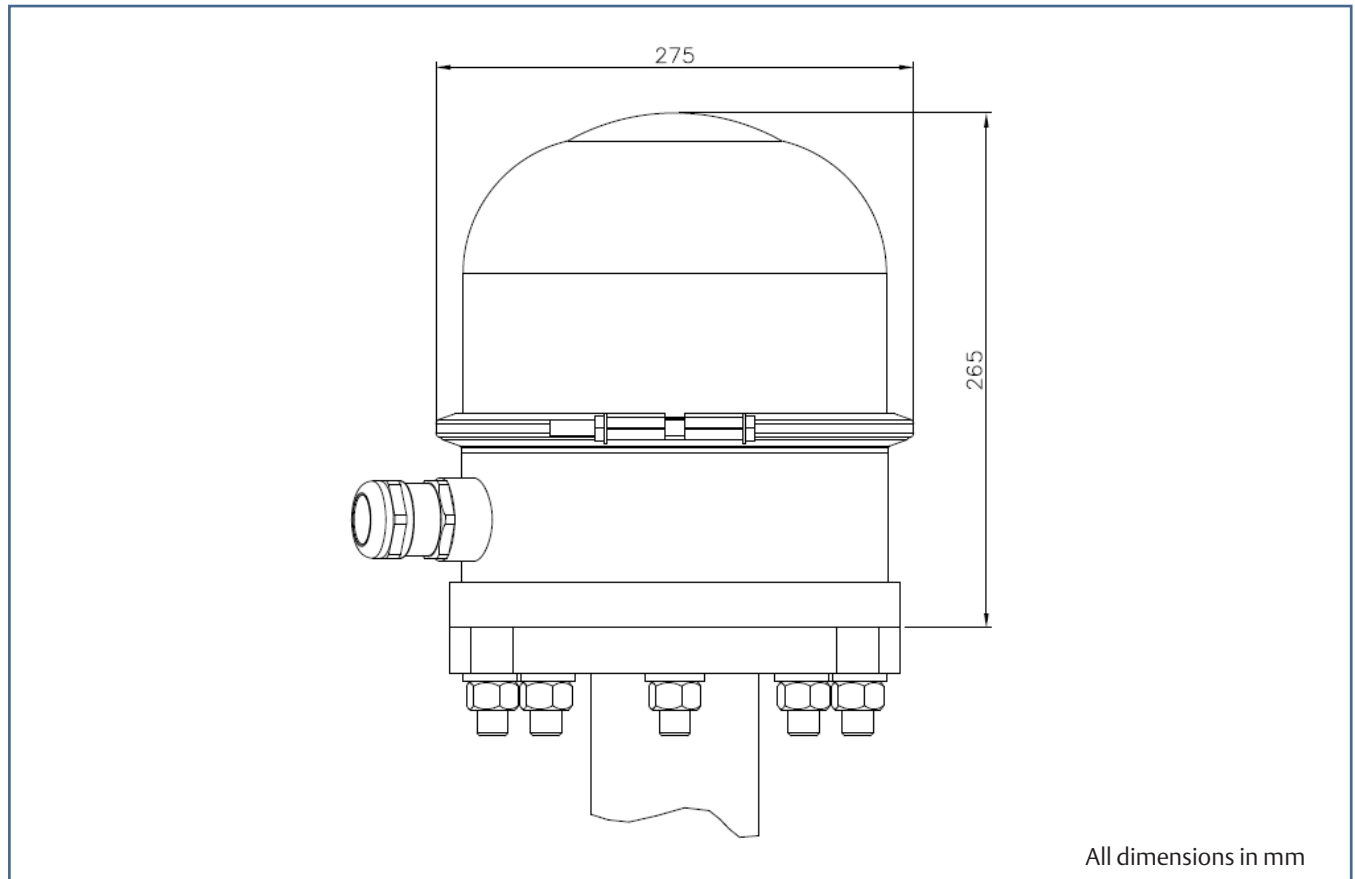

©2020 Emerson. All rights reserved.

The Emerson logo is a trademark and service mark of Emerson Electric Co. Rosemount and the Rosemount logotype are registered trademarks of Rosemount Inc. TankRadar is a trademark of Rosemount Tank Radar AB. Rosemount Tank Radar AB is a member of the Emerson family of companies. All other marks are the property of their respective owners.

Emerson Automation Solutions

Rosemount Tank Radar AB
Box 150
SE-435 23 Mölnlycke
T +46 31 337 00 00
F +46 31 25 30 22

www.Emerson.com/marine

The contents of this publication are presented for information purposes only, and while effort has been made to ensure their accuracy, they are not to be construed as warranties or guarantees, expressed or implied, regarding the products or services described herein or their use or applicability. Standard Terms and Conditions of Sale can be issued by contacting Rosemount Tank Radar AB. We reserve the right to modify or improve the designs and specifications of our products at any time without notice. Rosemount Tank Radar AB accepts no responsibility for any errors that may appear in this publication.