

Rosemount™ Tank Gauging System

High performance bulk liquid measurement
and overfill prevention solutions



Secure efficient operations, reduce risk and minimize measurement uncertainty with the scalable and open architecture Rosemount Tank Gauging System.

- Get certified custody transfer accuracy based on innovative radar technology
- Comply with the latest overfill prevention standards such as API 2350
- Increase safety with IEC 61508 certified SIL 2 and SIL 3 capable devices, and unique 2-in-1 technology
- Simplify automation and expansion with Emerson™ wireless solutions
- Improve inventory management and custody transfer operations with Rosemount TankMaster™ software
- Use gauge emulation to easily replace old mechanical gauges from other vendors

What if you could meet every challenge today and tomorrow?

Protect the value of your investment

There are always new challenges to face in a tank storage facility. Expansion or refurbishing projects mean you have to connect new equipment to your installation. This is also the case when you replace damaged or outdated technology. Emerson’s Rosemount Tank Gauging System lets you meet your challenges so you can increase plant efficiency and protect the value of your assets.

Works everywhere

Rosemount Tank Gauging System is suitable for all applications and tank types: pressurized or non-pressurized, with fixed or floating roofs. Applications include bulk liquid storage tanks in:

- Marketing terminals
- Refineries
- Aviation fuel depots
- Biofuel plants
- Distilleries
- Independent tank terminals
- Liquefied gas terminals (LPG and LNG)
- Petrochemical industries
- Pipeline terminals
- Power plants

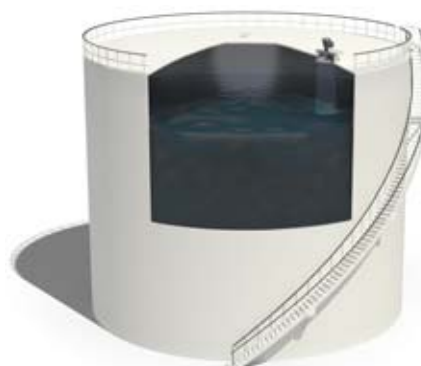

Fixed roof



Floating roof



Liquefied gas

Contents

System overview	3	System layout configurations	21
Key devices for tank gauging	8	Specifications	31
System functions	10	System certifications	38
Technology	11	Appendix	39

System overview

Rosemount Tank Gauging System measures and calculates tank data for custody transfer, inventory management, oil/product movement, mass balance and loss control, operational and blending control as well as leak detection and overfill prevention. The system can be configured to provide the following:

- Net volume calculations according to API (with Tank Master)
- Complete inventory, hybrid and custody transfer functions (with TankMaster)
- Total observed volume and observed density calculations in the Rosemount 2410 Tank Hub
- Level, level rate, temperature and free water interface level measurement
- Multiple spot temperature sensors for average calculations
- Vapor pressure and hydrostatic pressure measurement giving on-line density
- IEC 61508 certified SIL2/SIL3 level sensors for independent overfill prevention systems (OPS)
- Interoperability with all major DCS and host systems
- Automatic proof-testing without affecting tank operations

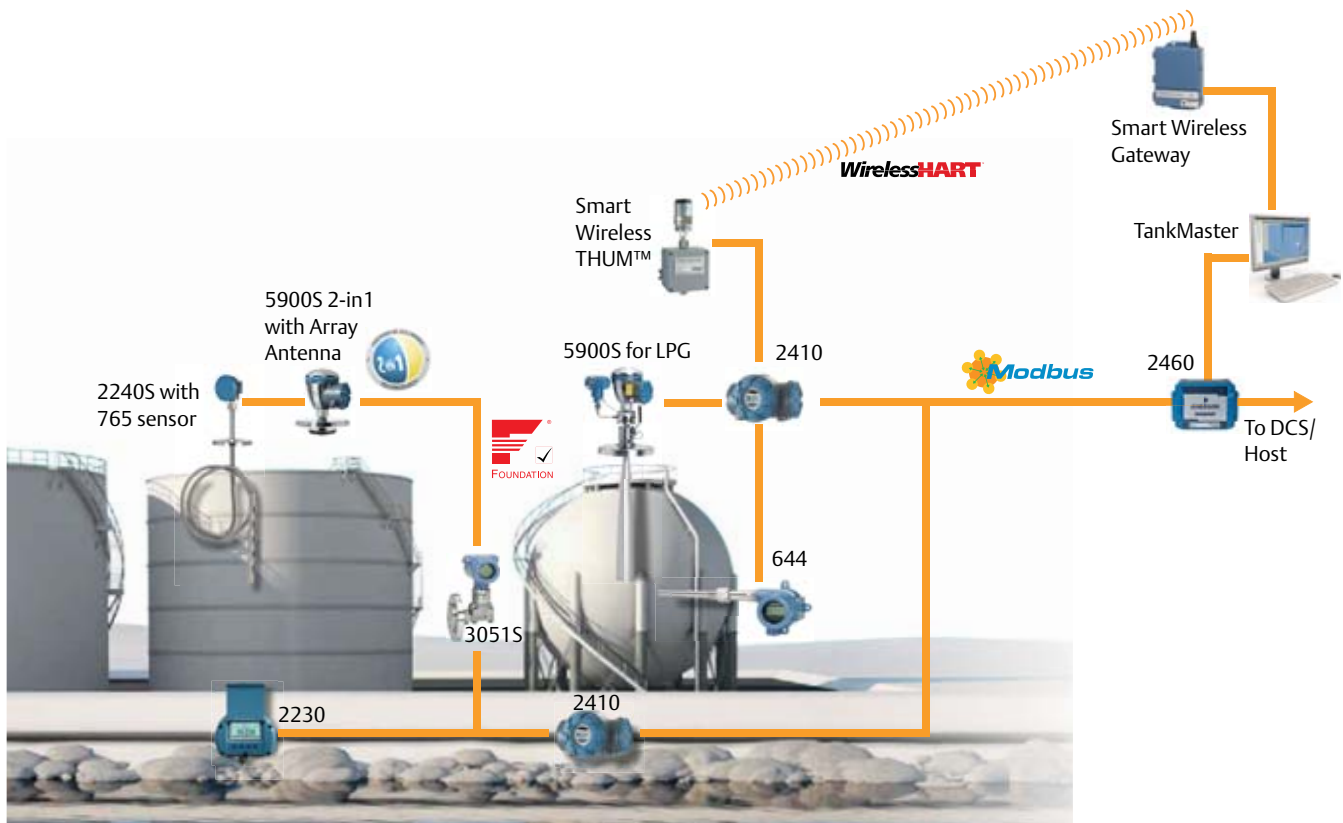

2-wire Intrinsically Safe (IS) self-configuring Tankbus enables cost efficient and safe installation.

Make the most of your tank farm

Boost plant efficiency

Having access to reliable and accurate real time tank inventory data is key to high plant productivity. Operators can handle more tanks, and safely fill them higher to better utilize the storage capacity. Rosemount Tank Gauging System is based on a scalable technology with open architecture, allowing you to improve efficiency step-by-step.

- Possible to combine devices freely – including devices from previous systems
- Automatic configuration of devices speeds up commissioning
- Wired and wireless networks can co-exist within the same system
- Installation can be done with tanks in operation (except for pressurized tanks)



Raise the level of safety

Lawmakers, corporate management, insurance companies, members of the community – demands for increased safety come from just about everywhere. Rosemount Tank Gauging System allows you to meet existing and future requirements at the same time as you protect plant assets, the environment and human lives.

- Continuous surveillance – radar level gauges are always in operation
- 2-wire intrinsically safe cabling on tanks
- IEC 61508 certified SIL 2 and SIL 3 capable level and alarm output devices
- 2-in-1 gauging allowing simultaneous level measurement and independent alarm functionality
- API 2350 overfill prevention guidelines and expertise available whenever you need it
- Automatic proof-testing without affecting tank operations



Certified SIL 2 or SIL 3 capable overfill safety



Unique 2-in-1 solution with full separation

Ensure precise measurements

Rosemount Tank Gauging System gives you precise data for certified custody transfer, inventory management and loss control. The level measurement accuracy of ± 0.5 mm (0.02 in.), together with the highest precision average temperature measurement, ensures exact net volume calculations. In cases where medium accuracy is sufficient, we offer a number of cost-effective gauging instruments.

- Level gauges with no moving parts and only the antenna inside the tank
- Custody transfer certification by OIML as well as many national institutes
- Precise measurement lets you stay in control of inventory and custody transfer
- Keep accurate track of leaks and overfills



Transmitter for 3- or 4-wire calibrated average temperature sensors



Display and communication hub for wired and wireless data



Ultra-precise radar level



Pressure measurement for online mass and density

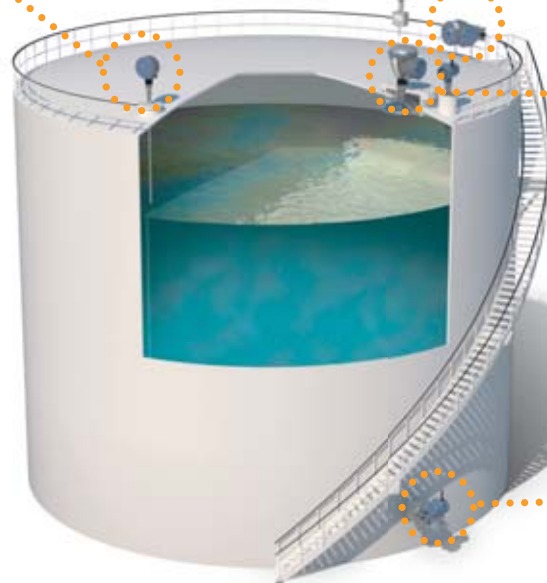

Use modern technology to go further

Reach more tanks at less cost

Wireless tank gauging allows for installation cost savings by up to 70 percent. Rosemount Tank Gauging System supports Emerson’s wireless technology, based on the wireless field network industry standard IEC 62591 (*WirelessHART*®). The wireless network is self-organizing and automatically finds the best way around any obstacle.

Wireless data transmission gives you a lot of benefits and opportunities:

- No need for digging and trenching in a potentially complicated and dangerous tank environment
- Possible to connect tanks located far away and divided by water or roads
- Easy to automate all bulk liquid storage measurement
- Redundant communication can be created without time-consuming cabling work
- Downtime for expansion, upgrading and maintenance is kept to a minimum

WirelessHART



Meet the future with emulation

Emulation technology lets you replace old level gauges from all major vendors, with modern radar-based tank gauging using your existing field wiring and host system.

- Easy way to upgrade your tank gauging system at a pace that suits you
- New and accurate devices make it possible to improve efficiency and safety
- Precise data strengthens tank inventory control allowing increased throughput

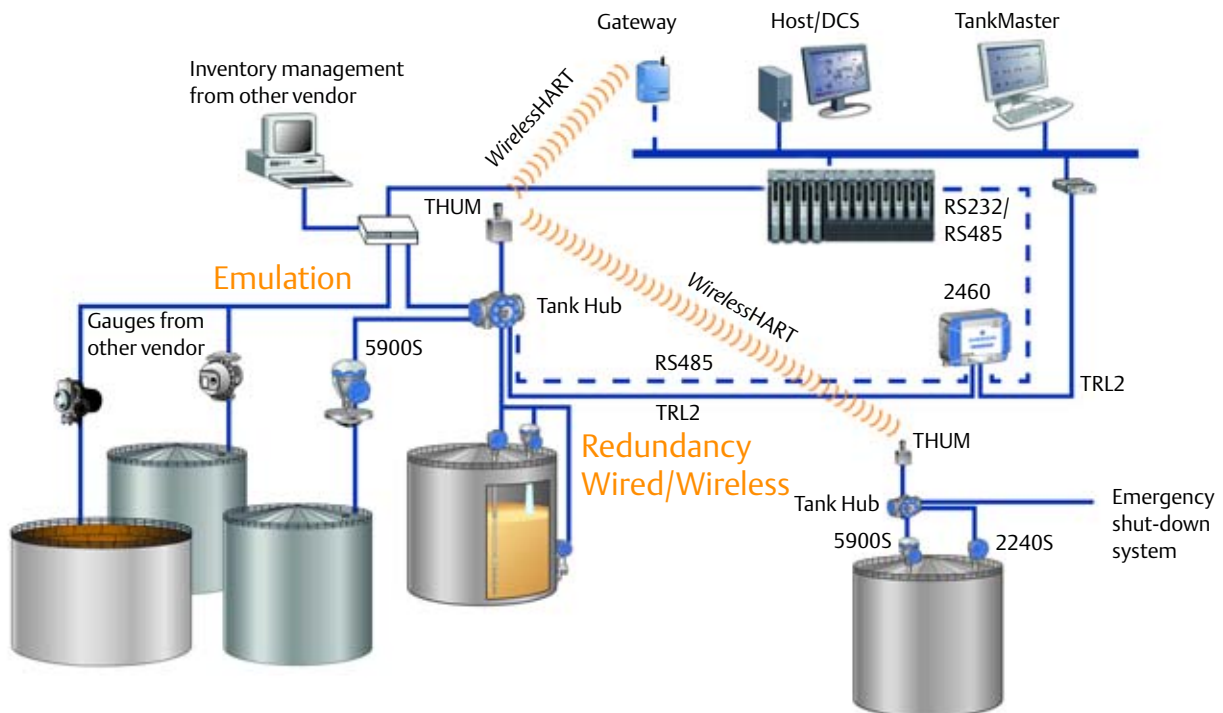

Stay in control with TankMaster

TankMaster is a Windows™-based software that provides a real-time overview of Rosemount Tank Gauging System. Data can be shared with users on all levels and information can be accessed via the Internet, wherever you are.

- Graphic plant layout with customized views for efficient operations
- Alarm handling via screen, email or text message
- Batch handling available to control transferred volumes
- Audit logs and reporting can be used to record and trace operations
- Possible to seamlessly replace other tank management systems with TankMaster

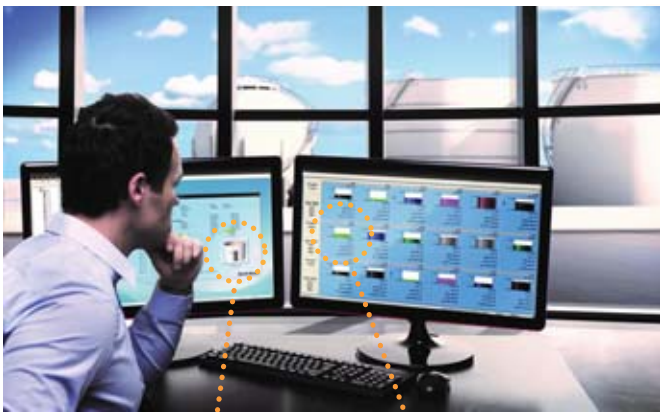

Complete single tank gauging inventory data



Tank farm overview with Net Standard and Overall Volume

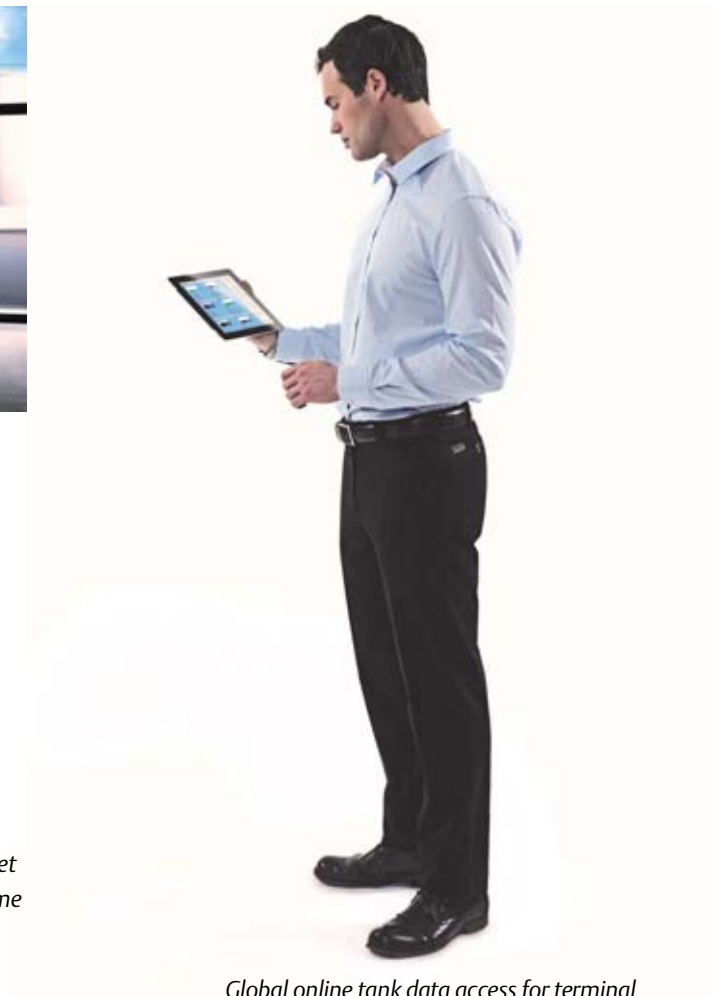

Global online tank data access for terminal customers and corporate headquarters

Key devices for tank gauging

For decades, Rosemount radar level gauges have been the obvious choice when precision is critical. The 5900S gauge builds upon this legacy by offering level measurement accuracy of ± 0.5 mm (0.02 in.). Even if accuracy is important, the need can vary. This is why we include gauging solutions for both demanding custody transfer, with full inventory management functionality as well as applications where accuracy is less critical. See [Appendix A](#) for list/links to Product Data Sheets for each device.

Radar level gauges

Rosemount 5900S Radar Level Gauge

Non-contacting, ± 0.5 mm (0.02 in.) ultra-high performance level measurement. Antennas available for all tank types.



Rosemount 5900C Radar Level Gauge

Reliable ± 3 mm (0.12 in.) non-contacting measurement. Antennas available for all tank types.



Rosemount 5300 and 5400 Radar Level Transmitters

Guided wave radar and non-contacting radar level transmitters for medium accuracy, non-inventory grade applications.



Temperature and free water level

Rosemount 2240S Multi-input Temperature Transmitter

Ultra-stable temperature measurement.



Rosemount 565, 566 and 765 Sensors

3- or 4-wire calibrated temperature sensors and free water level measurement. Up to 16 Pt-100 spot elements per sensor.



Rosemount 644 Temperature Transmitter

For single-point temperature measurement.



Rosemount 65 and 68 Single Point Temperature Sensors

Single-point Pt-100 temperature measurement.



Pressure

Rosemount 3051S Pressure Transmitter

Enables online density, mass and vapor pressure measurement.



Rosemount 2180 Field Bus Modem

Used for connecting a TankMaster PC to the TRL2 field bus.



Communication and accessories

Rosemount 2410 Tank Hub

Collects and transfers data from one or several tanks. Enables emulation, wireless communication and SIL certified overfill prevention.



Smart Wireless Gateway 1420/1410

Connects wireless self-organizing networks with any host system.



Smart Wireless THUM Adapter

Adds wireless to all measurement points.



Rosemount 2460 System Hub

Transfers tank gauging data to TankMaster Inventory Management System and/or Host/DCS.



Rosemount TankMaster Inventory Management Software

Gain control over your inventory data. In addition use it for system configuration.



Rosemount 2230 Graphical Field Display

Remote data access at tank top or ground level.



Rosemount 2100 Series Liquid Level Switch

Alternative option with point level switch when gauge in constant operation is not used for overfill prevention.



Segment Coupler

Junction box which distributes the Tankbus to multiple tanks and/or transmitters (alternative to daisy-chaining).



Cabinet

Customized cabinets for wiring connections, communication devices and servers.



System functions

Depending on system configuration, Rosemount Tank Gauging System performs the below functions. For a more detailed list of Inventory management functions, see TankMaster Product Data Sheet, document number 00813-0100-5110.

Measurement of:⁽¹⁾

- Tank level
- Level rate
- Free water level (interface)
- Average liquid temperature (only elements in liquid are considered)
- Spot temperature
- Vapor and liquid pressure
- Density
- Gross volume based on 100 strapping points
- Gross volume based on 5000 strapping points (TankMaster)
- Net volume according to API standards (TankMaster)
- Mass (TankMaster)

Data communication functions

- Digital communication with other systems, DCS, SCADA, PLC, Enterprise system etc (OPC, RS232, Ethernet etc)
- Emulation of other vendor's field bus/gauges
- Emulation of other vendor's control room HMI
- Modbus® or FOUNDATION™ Fieldbus wired transmission of data
- WirelessHART transmission of data

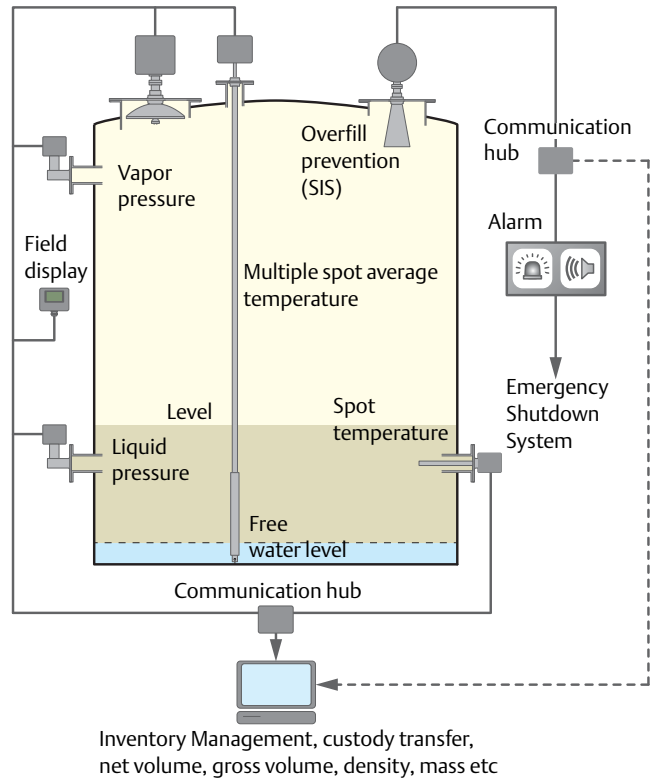

Other functions

- Operator graphics and HMI (TankMaster)
- Alarm handling
- Relay outputs for overfill prevention alarms (SIL)
- 4-20 mA SIL output
- Relay outputs for overfill prevention and other alarms (non-SIL)
- Leak alarms (TankMaster)
- Batch reporting (TankMaster)
- Log reports (TankMaster)
- Mass balance reports (TankMaster)
- Historical data sampling (TankMaster)
- Internet connection (TankMaster)
- System configuration and setup (TankMaster)

1. All measurement data can be displayed in field or control room, except the ones marked "TankMaster" which are available in control room/office only.

Technology

Radar level gauging

Rosemount radar level gauges provide outstanding reliability with no moving parts and only the antenna inside the tank. For radar level measurement, there are mainly two modulation techniques:

- Frequency Modulated Continuous Wave, FMCW**, is used by high performance radar level gauges. Rosemount 5900S uses FMCW, together with digital reference and filter technology which enables custody transfer accuracy.
- Pulse method**, measures the time it takes for a pulse to travel to the surface and back. The time difference is converted to a distance, from which the level is calculated. Rosemount 5400 uses this technique. One special case of the pulse method is the Time Domain Reflectometry (TDR) technology, as used in Rosemount 5300, where a low power nano-second pulse is guided down a probe towards the process media surface, where it is reflected back.

The radar gauge/transmitter consists of a transmitter head and an antenna. The transmitter head can be combined with any antenna type in the same gauge series, minimizing spare parts requirements. No matching of transmitter head and antenna is required, which means the transmitter head can easily be replaced without opening the tank.

The FMCW method

The FMCW-based radar gauge transmits microwaves towards the surface of the liquid. The microwave signal has a precise linear frequency variation, around 10 GHz for the 5900 Series.

When the signal has traveled down to the liquid surface and back to the antenna, it is mixed with the signal that is being transmitted at that moment.

The reflection from the liquid surface has a slightly different frequency compared with the signal transmitted from the antenna.

The difference in frequency is measured, and it is directly proportional to the distance to the liquid surface. This technology provides a measured value with high accuracy.

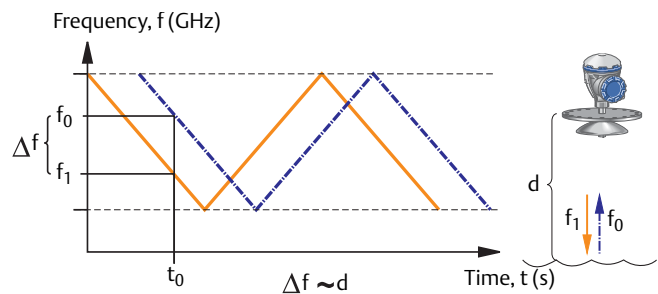

Technology for real world tank applications

Since the 5900 Series antenna has an inclined polished PTFE surface where microwaves are emitted, it will be less susceptible to condensed water or product. The drops of condensation will not cover the active part of the antenna, and the radar signal will not be attenuated. This results in a higher accuracy and better reliability.



Antenna design with no horizontal surfaces according to the American Petroleum Institute Standard (API ch. 3.1B ed.1).

Rosemount 5900 Series radar level gauges with parabolic antennas are designed also for harsh environments like bitumen tanks. The antenna in the picture is in operation after having been exposed to blown bitumen at 220 °C (430 °F) for several months.



The 5900 Series with still-pipe array antenna uses the Low Loss Mode technology transmitting radar waves close to the pipe centerline. This technology virtually eliminates signal and accuracy degradation due to rust and product deposits on the inside of the pipe wall.



For best measurement performance in LPG applications an integrated pressure sensor enables corrections for vapor influence. Measurements in closed tanks can be verified using a reference pin with a known distance to the antenna.



The still-pipe used for LNG and LPG ensures adequate signal strength from the surface also when the liquid is boiling.



LPG radar gauge with pressure sensor.

Open and scalable system architecture

The standard system can include a wide range of devices making it easy to build a large or small customized tank gauging system. Thanks to the modular design, a system can easily be expanded/upgraded.

All field devices are connected on the Tankbus which is based on the open industry standard, FOUNDATION Fieldbus.

Lower cost and easier commissioning

Rosemount Tank Gauging System supports plug-and-play technology for trouble-free installation.

All fieldbus segments in a system are autoconfigured minimizing the need for specific FOUNDATION Fieldbus knowledge.

The existing field cabling can normally be used. No special tools are required, and all parts can easily be carried to the tank roof.

Installation can be done with tanks in operation, except for pressurized tanks, such as Liquefied Petroleum Gas (LPG).

Intrinsically safe cabling on tank

The system is designed to minimize power consumption, which enables use of 2-wire intrinsically safe technology. The field devices are powered by the Tankbus via the 2410 Tank Hub using the FISCO (FOUNDATION Fieldbus Intrinsically Safe Concept). This solution has several advantages:

- Increased safety at system start-up and operation
- Installation is quicker and easier due to less cabling
- Cables without conduits can be used

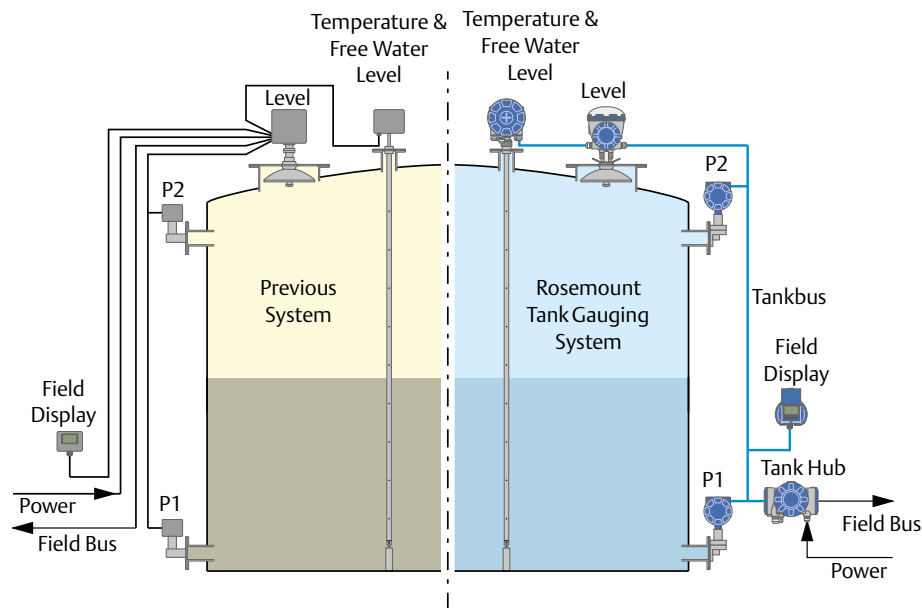

Integration with other systems

The Rosemount system can be connected to all major suppliers of DCS, SCADA systems, plant host computers or terminal automation systems. Integration can be made in several ways via:

- TankMaster PC
- Rosemount 2460 System Hub
- Rosemount 2410 Tank Hub
- Direct connection to the tank devices, if the host system is based on FOUNDATION Fieldbus (no 2410 or 2460 hub included in this case)

Using a connection to TankMaster gives the advantage of communicating both measured values and inventory data.

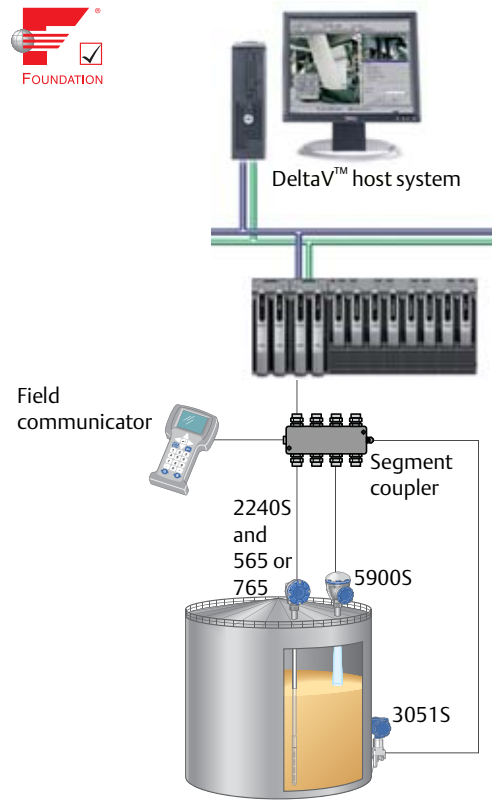

Tank gauging devices directly connected to a FOUNDATION Fieldbus host system.

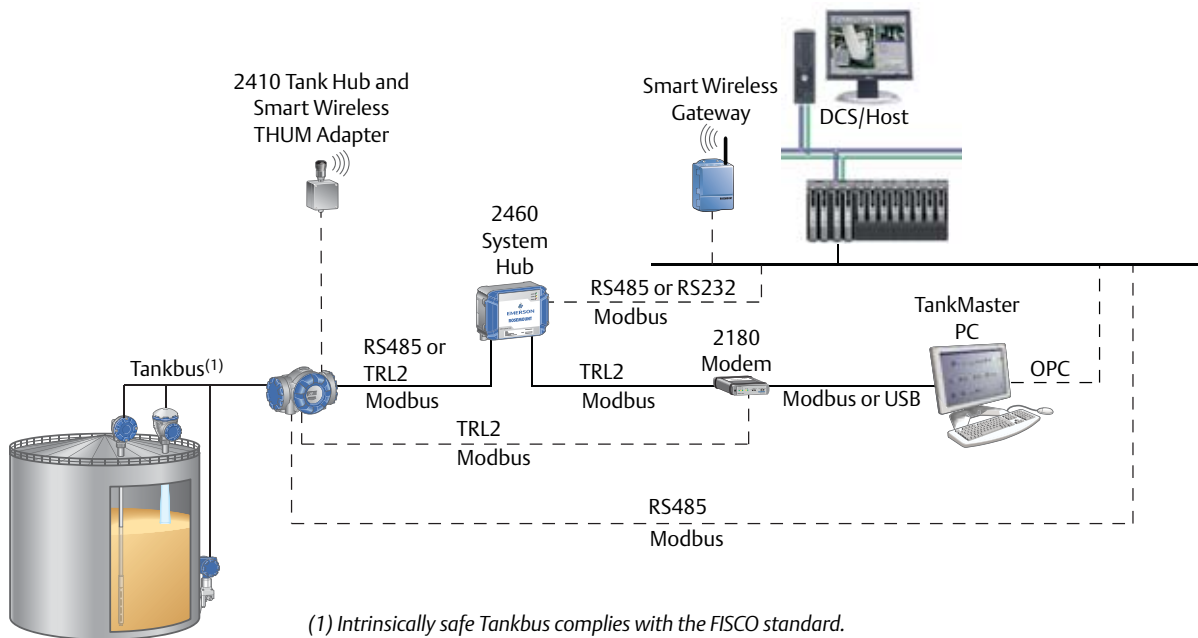

(1) Intrinsically safe Tankbus complies with the FISCO standard.

Connection to a host system can be made via 2410, 2460, a TankMaster PC or directly.

Reduce the risk of tank overfills

Rosemount Tank Gauging System can be used as part of a highly reliable automatic or manual overfill prevention system. In such Safety Instrumented System (SIS) applications, level measurement is duplicated in one Basic Process Control System (BPCS) Layer and one independent Functional Safety Layer.

The 5900 Series gauges and tank hubs are IEC 61508 certified SIL 2 or SIL 3 capable. They include separate certified alarm loop relays or analog output functionality.

Innovative 2-in-1 technology saves installation cost and reduces complexity by enabling the 5900S gauge to provide dual level data in two independent layers of protection using only one housing and a single tank nozzle. The level output from the safety layer sensor is available as redundant level measurement data.

One important advantage is that the 5900 Series gauge is in constant operation. Unlike a conventional switch, it provides continuous information about its status and performance, since it is being used in everyday tank farm operations.

In addition, the alarm level can easily be set to any chosen value.

The level value from the radar level gauge is transferred on the digital bus to a TankMaster PC or other host system, whereas the alarm signal uses the separate relay or analog output in the Tank Hub. Follow the recommendations in the Safety Manual (document number 00809-0200-5100). See also some available SIS/BPCS configuration examples on page 23 to 26.

The Rosemount gauging system supports all categories covered by the API 2350, revision 4, which is the first internationally recognized tank gauging standard for overfill prevention. It covers not only instrumentation but also procedures and processes for the whole plant/terminal life cycle, including the requirements for establishing a detailed risk assessment. See “The Complete Guide to API 2350”, document number 00821-0100-5100 and “The Engineer’s Guide to Overfill Prevention”, document number 00805-0100-1042.

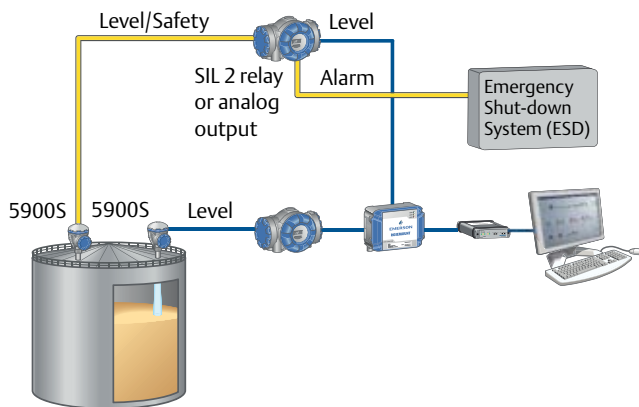

SIL 2 certified system with dual gauges.

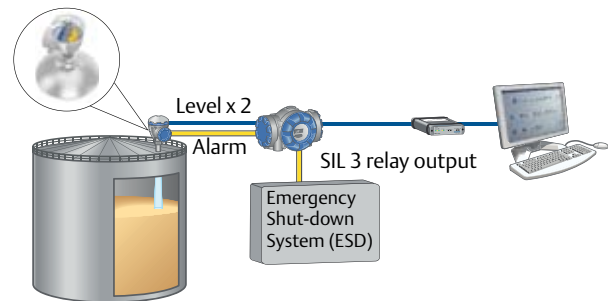

SIL 3 certified system with unique 2-in-1 gauge.

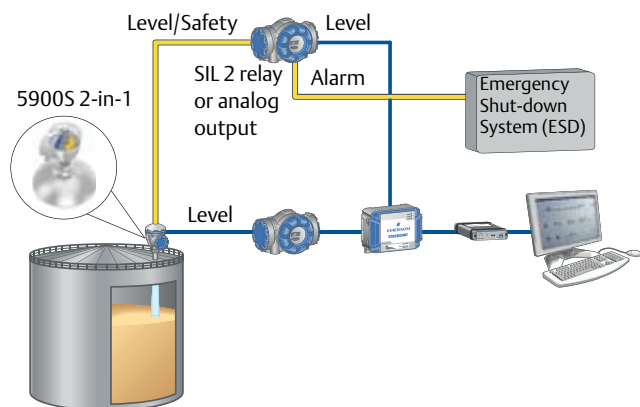

SIL 2 certified system with unique 2-in-1 gauge.

Use wireless technology to reach more tanks at less cost

Rosemount Tank Gauging System supports Emerson’s wireless technology, based on IEC 62591 (*WirelessHART*), the industry standard for wireless field networks. Reducing field wiring leads to substantial savings in infrastructure, design and labor required for installation and commissioning.

In addition, the time between project start-up and an up-and-running wireless system is drastically reduced. Wireless tank gauging allows for cost savings up to 70%, and gives other benefits as well.

Better utilization of tank capacity

Wireless functionality allows tank gauging data from remotely located tanks, previously collected manually or not at all, to be integrated into the system. This results in a more efficient tank capacity utilization, better inventory and loss control.

Self-organizing field network increases reliability

A wireless device can transmit its own data as well as relay information from other devices in the network. The self-organizing field network automatically finds the best way around any fixed or temporary obstacle. Nodes can identify a network, join it, and self-organize into dynamic communication paths. Reliability increases when the network expands – the more devices, the more communication paths. For fastest update rate, direct hops to the gateway are required.

Emerson wireless solution for more secure data transmission

Emerson’s wireless field network is designed for best-in-class security. Data is protected by 128-bit encryption, authentication, verification, anti-jamming, and key management.

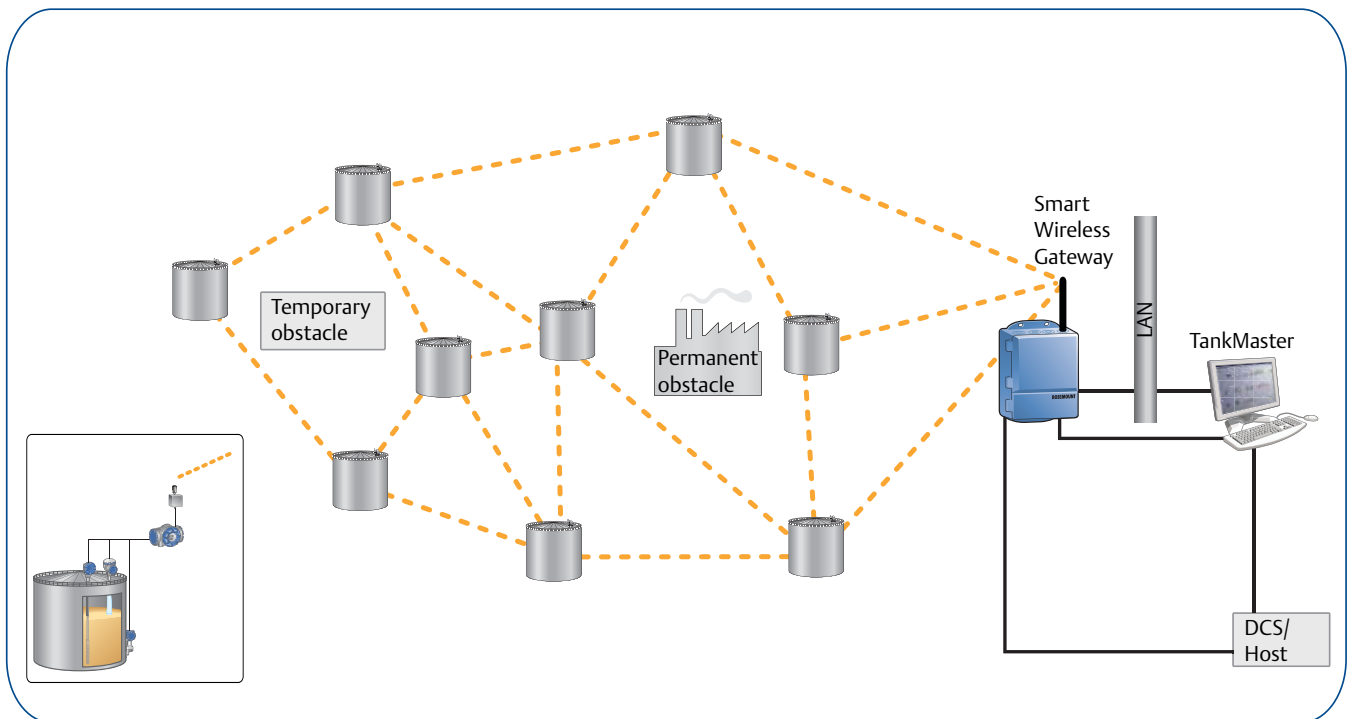

All wireless devices communicate with the host system through the Wireless Gateway. A Rosemount Tank Gauging System can consist of both wired and wireless networks.

Wireless connection of tank gauging equipment

The Smart Wireless Gateway is the network manager that provides an interface between field devices and the TankMaster inventory software or host/DCS systems. Both the 1410 and 1420 gateways are supported.

Each wireless node in the Rosemount Tank Gauging System consists of a Rosemount 2410 Tank Hub and either a 5900 Series gauge or one or several 5300/5400 transmitters plus the other tank devices. Rosemount 2410 is connected to mains power, and a Smart Wireless THUM Adapter.

The tank gauging system can be complemented with other wireless devices, such as pressure and temperature transmitters.



Smart Wireless Gateway.



The wireless transmission supports measurement data handled by the tank devices, such as level, temperature, free water level and pressure.

Easy step by step installation using emulation

The Rosemount gauging system is compatible with all other major tank gauge vendors. Step-by-step modernization of an existing tank gauging system is possible using available field and control room solutions.

Gauge emulation

Many old mechanical float or servo gauges from other vendors can be upgraded with modern Rosemount level and temperature devices and a 2410 Tank Hub, using the existing tank openings, field cabling, and control system. By replacing mechanical gauges, it is possible to avoid re-calibration and the expenses associated with spare parts and maintenance.

The new radar gauge is normally installed with the tank in operation. No hot work is required. The 2410 has an open design, covering everything from electrical interface and communication protocol to utilization of different power sources.

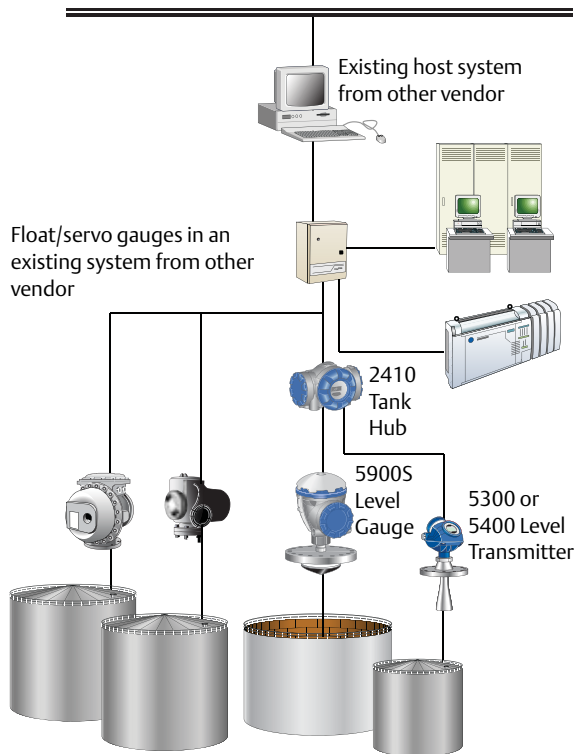

A Rosemount gauge seamlessly replaces another device, independent of measurement technology. Data from the tank is displayed as before on the existing inventory management system.

Seamless control room connectivity

In addition, other tank management systems can be seamlessly replaced with the Rosemount TankMaster software, and the 2460 System Hub supports emulation of other vendors' control room devices. Rosemount TankMaster can replace an existing inventory management system, still being able to communicate with the field devices in use. This solution provides interoperability, and problem-free communication with existing field devices, often with a better update rate than before.

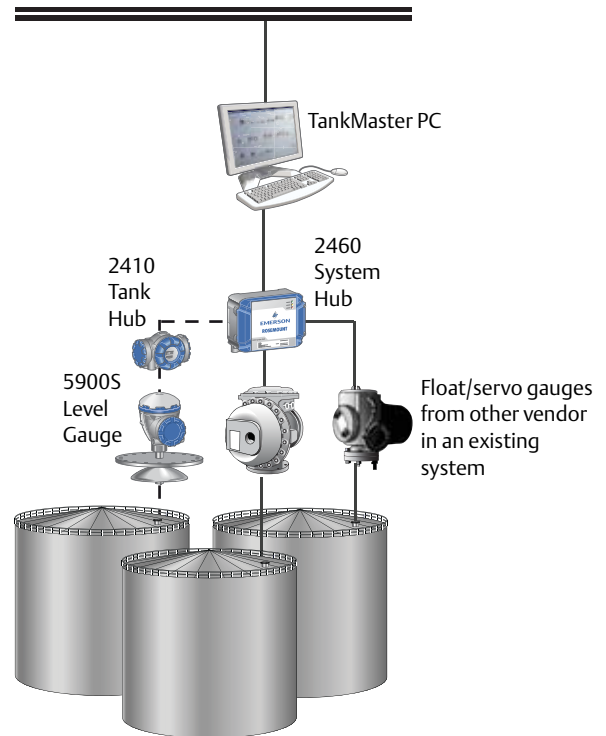

Replacing old tank monitoring software with TankMaster.

Tank gauging as a system application

Tank gauging is an integrated system application which has quite specific requirements on the measuring devices in the system. These requirements vary depending on how the system is used. A Rosemount gauging system can be configured with highest accuracy for custody transfer/inventory control, or with medium accuracy required for less critical applications.

- Custody Transfer
- Inventory Control
- Oil Movement/Operations
- Overfill Prevention
- Leak Detection

- Oil Movement/Operations
- Overfill Prevention

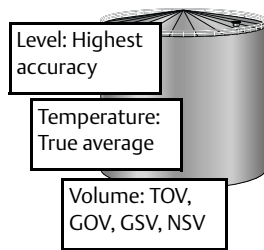

High Performance Configuration

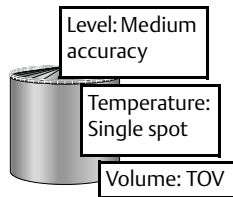

Non-inventory Grade Configuration

High performance inventory and custody transfer applications

A Rosemount gauging system used for custody transfer gives accurate measurement values for volume calculation. This calculation requires a selection of suitable devices to obtain high performance for measurement of level, free water level, average temperature, and in some cases reference density. If any of these sensors is poorly matched, the result of the standard volume calculation may suffer. Similar conditions apply for inventory measurements, for which the net standard volume is important. For mass balance and loss estimation, the calculated mass is in focus.



Rosemount Tank Gauging System includes equipment for high accuracy measurement and calculations such as:

- Level: 5900S
- Temperature and Free Water Level: 2240S with 565/566 or 765 Sensors (3- or 4-wire sensor with up to 16 spot elements)
- Pressure: 3051S
- Software: TankMaster WinOpi

System devices exchange measured digital data between units in order to optimize functionality. For instance, product temperature measurement functions use level information for calculation of average product temperature. Data from pressure transmitters is used to calculate density etc.

Operation and configuration

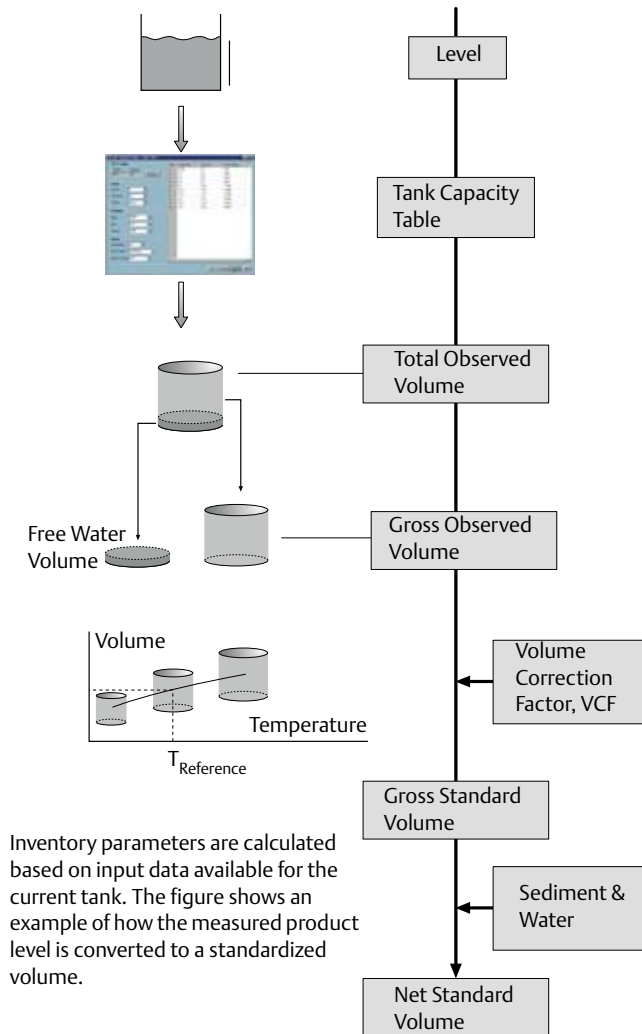

Non-inventory grade applications

In a system primarily intended for oil/product movement, level and observed volume (TOV) are important parameters, but do not necessarily require highest accuracy. The Rosemount gauging system includes the following equipment for non-inventory grade measurement and calculations:

- Level: 5300 or 5400
- Temperature: 644 Transmitter with 65 or 68 Sensor
- Software: TankMaster WinView

The TankMaster software is the operator’s interface to the system. This user-friendly software package complies with the OPC data access industry standard. It gives the operator a good overview and quick access to any measured values.

This software provides a wide range of inventory and custody transfer functions such as net volumes according to API/ISO standards, reporting, alarms, graphics, trends, batch handling etc.

The TankMaster software is in addition the primary configuration tool. Basic configuration can also be done with a Field Communicator, the AMS™ Suite or DeltaV.

Protocols for communication with major suppliers of plant host computers, such as DCS or SCADA, have been developed and certified. In many cases the plant’s DCS/SCADA system works as the operator’s interface for tank management data from the Rosemount system.

System layout configurations

Open architecture enables the most cost effective layout

Rosemount Tank Gauging System supports a large number of configuration combinations. It can incorporate both 5900S, 5900C, 5300 or 5400 based configurations, networks with previous generations of Rosemount radar gauges (TRL2, Rex, Pro), and even gauges from other vendors.

Wired and wireless networks can co-exist within the same system. This flexibility enables a step-by-step upgrade.

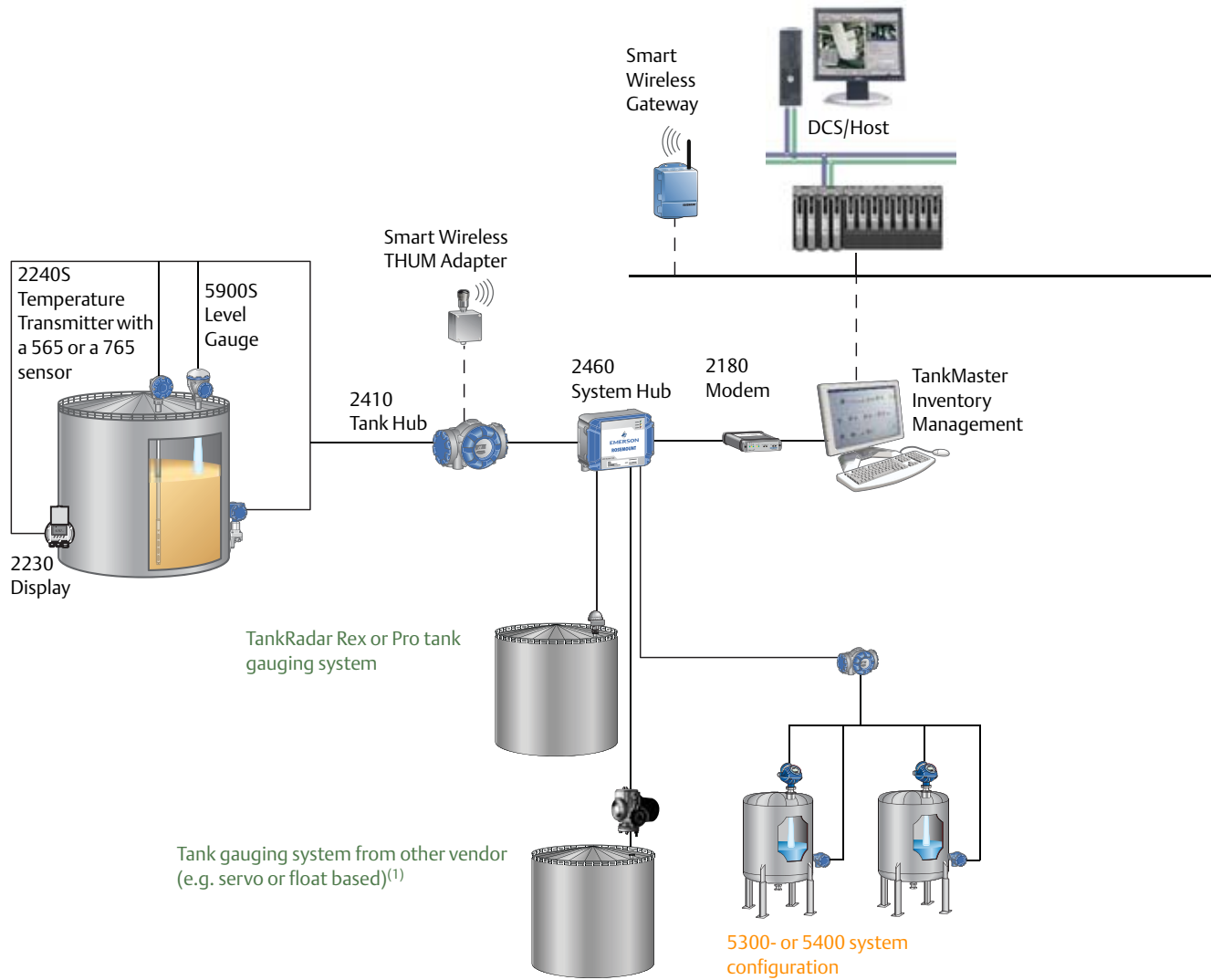

1. Requires Rosemount 2460 System Hub.

Custody transfer and inventory tank gauging – 5900S system configuration

The 5900S based tank gauging configuration is used for the highest demands on accurate measurements for inventory management and custody transfer. Precise net volume is calculated using tank strapping tables and compensation for temperature and tank characteristics.

For temperature measurements, the 2240S Temperature Transmitter is combined with the 565 or 765 Multiple Spot Temperature Sensors. The 3051S transmitter is used for pressure measurements.

Each tank has a designated Rosemount 2410 Tank Hub.

All values are transferred to the TankMaster software which has a complete set of inventory and custody transfer functions. TankMaster includes an API/ISO calculator for volume and density.

When custody transfer precision is not required, the 5900S can be replaced by the 5900C Radar Level Gauge.

High precision system

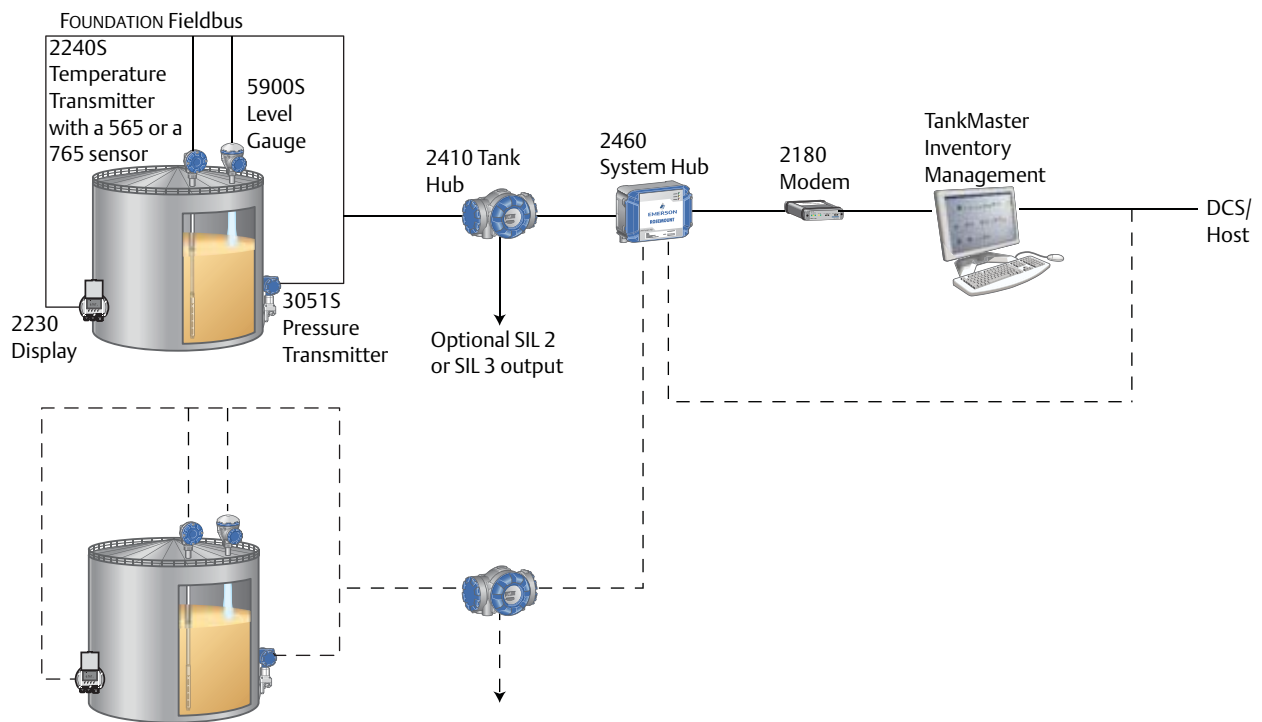

Functional safety configurations for overfill prevention

The process and terminal industries apply independent protection layers (IPLs) to minimize the risk of a potential hazard such as tank overfills.

Rosemount Tank Gauging System supports a number of SIS (Safety Instrumented Systems) configurations designed for overfill prevention. Which configuration is most suitable depends on a number of factors such as type of storage tank, existing instrumentation, Safety Integrity Level etc.

Integrated Emerson Solution for Automatic Overfill Prevention System (AOPS) and Tank Gauging

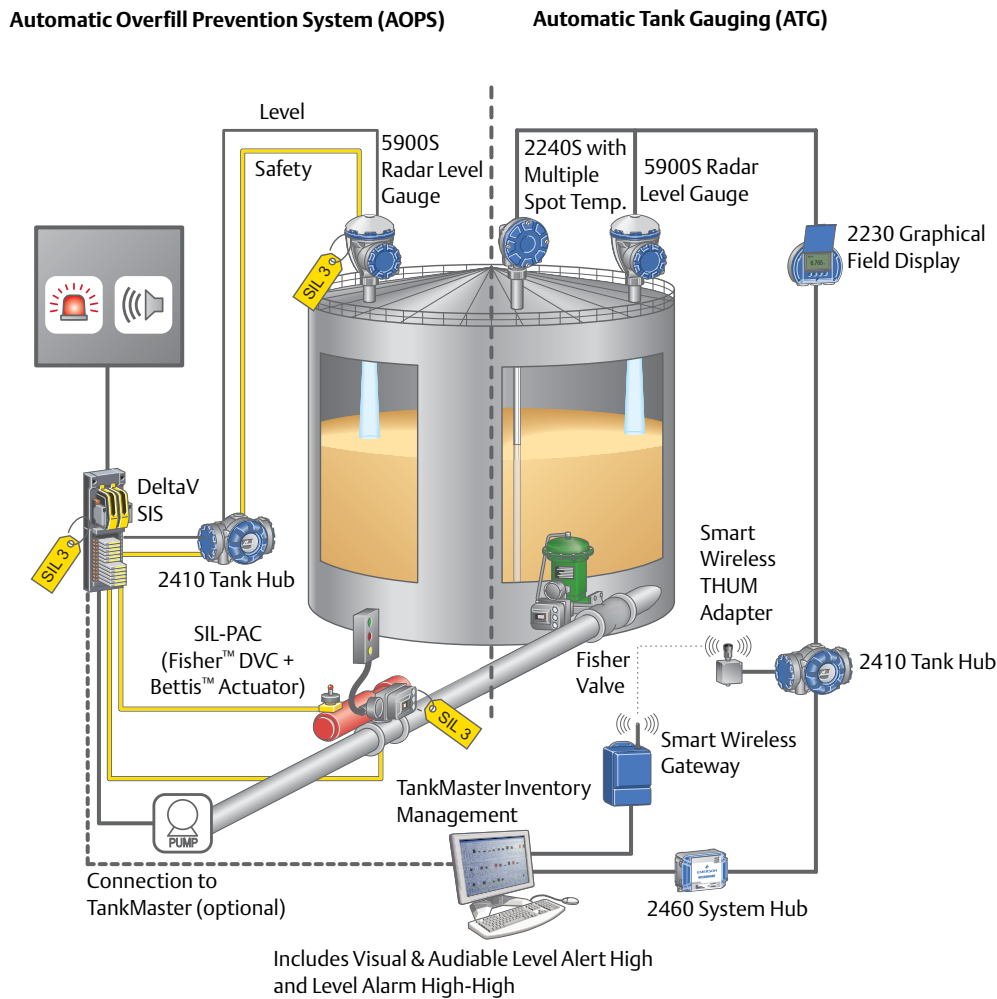

Floating Roof AOPS 2-in-1

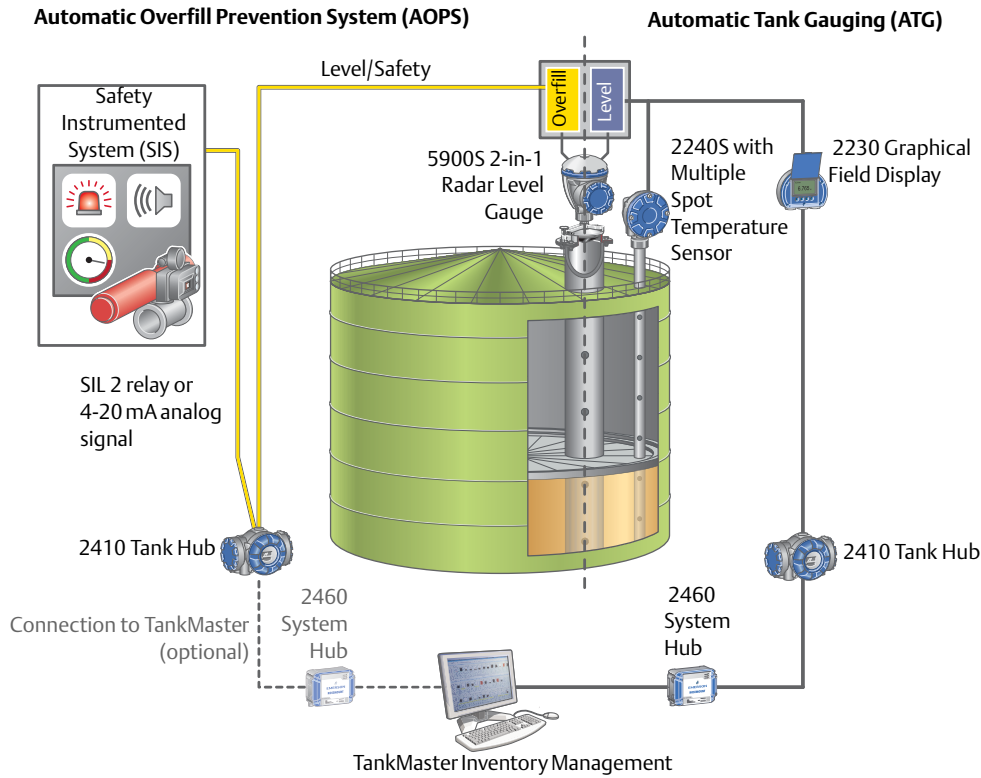

Sphere AOPS 2-in-1

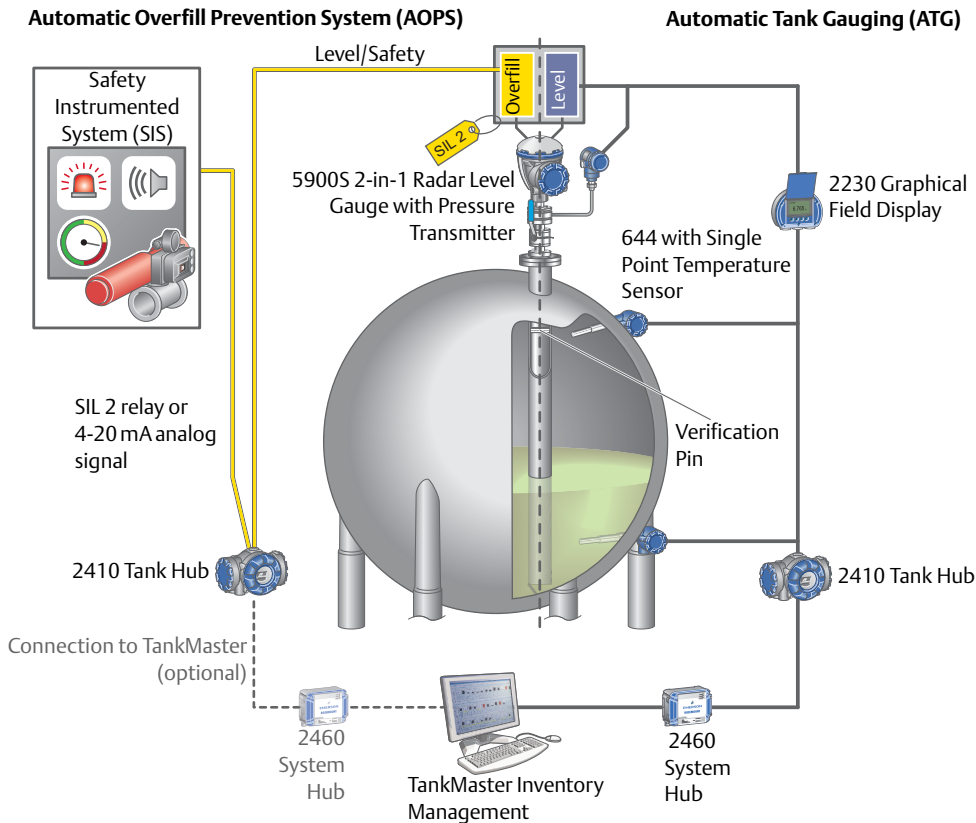

Fixed Roof AOPS

Automatic Overfill Prevention System (AOPS)

Automatic Tank Gauging (ATG)

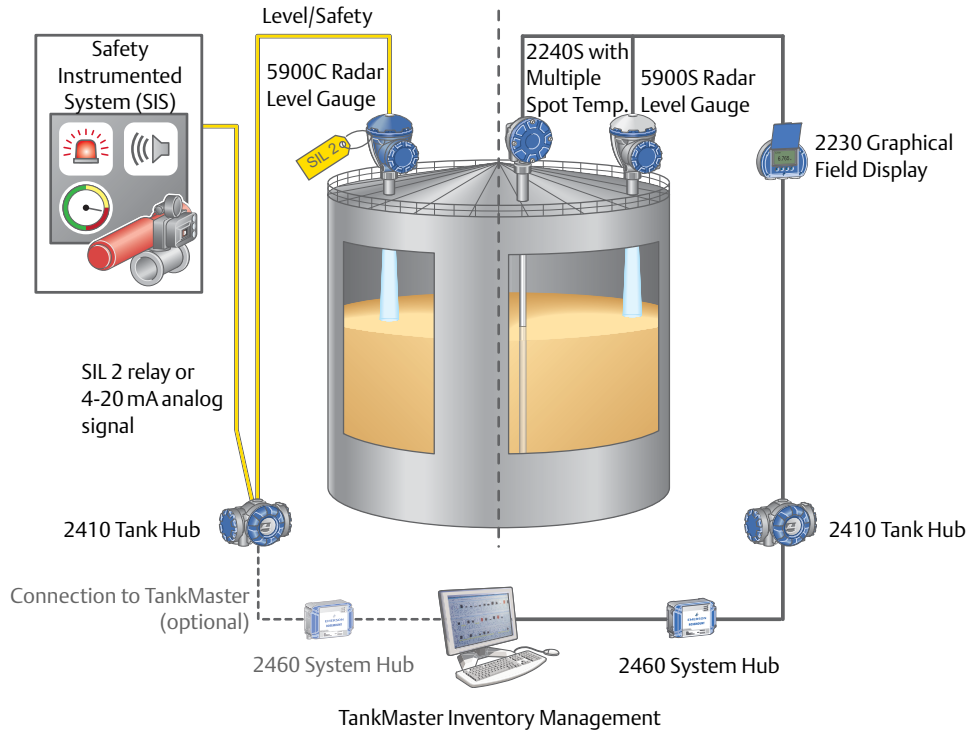

Pressure Vessel AOPS

Automatic Overfill Prevention System (AOPS)

Automatic Tank Gauging (ATG)

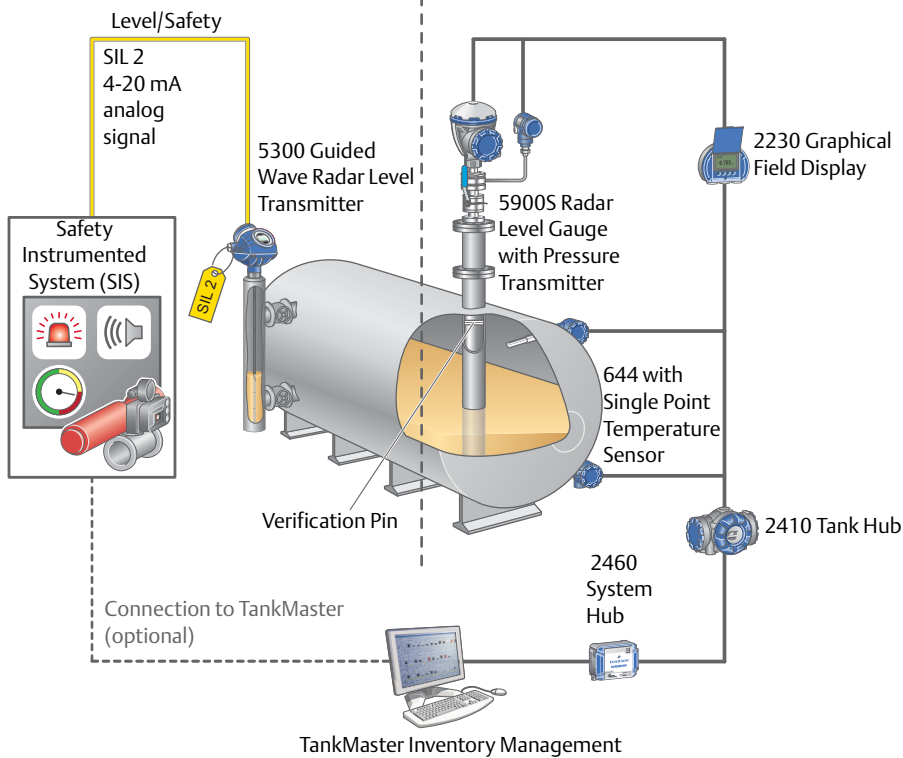

Fixed MOPS 5900S Including Level Switch

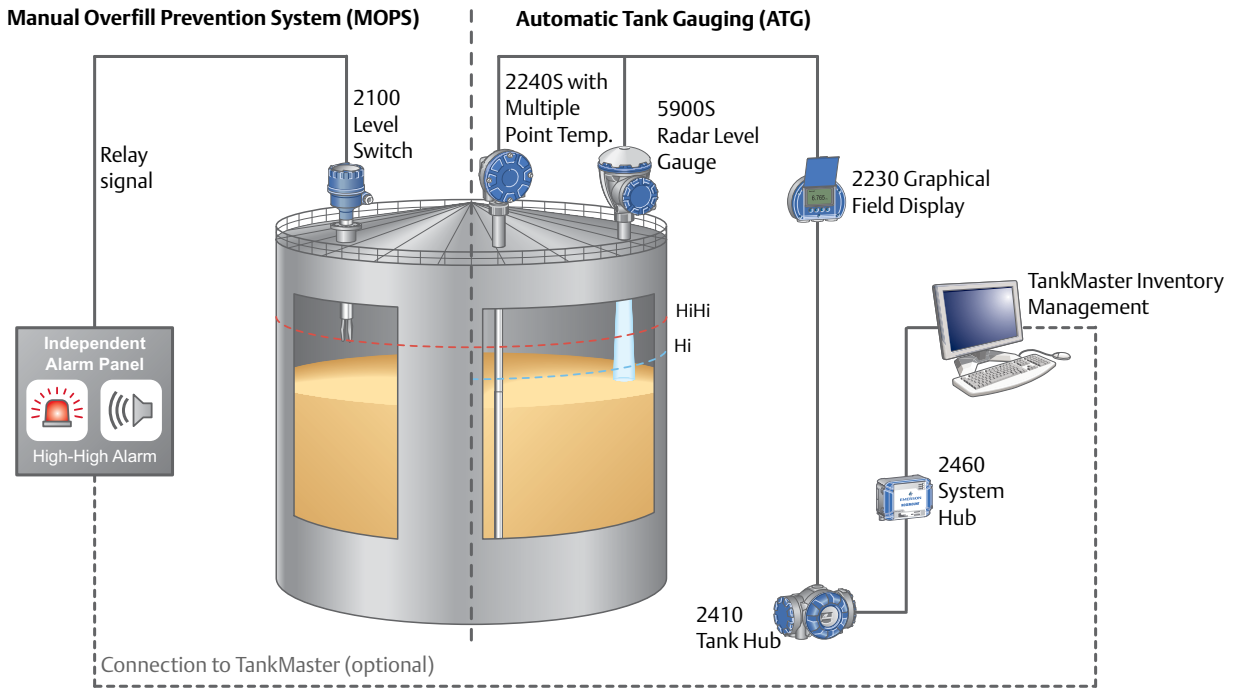

Wired and wireless combination

Wired and wireless may be combined within the Rosemount Tank Gauging System for most cost effective access to data.

It is possible to connect a wireless Rosemount gauging system to any existing wired tank gauging system, or in addition add a wireless connection to a tank with wired communication to achieve system redundancy (see [Figure on page 6](#)).

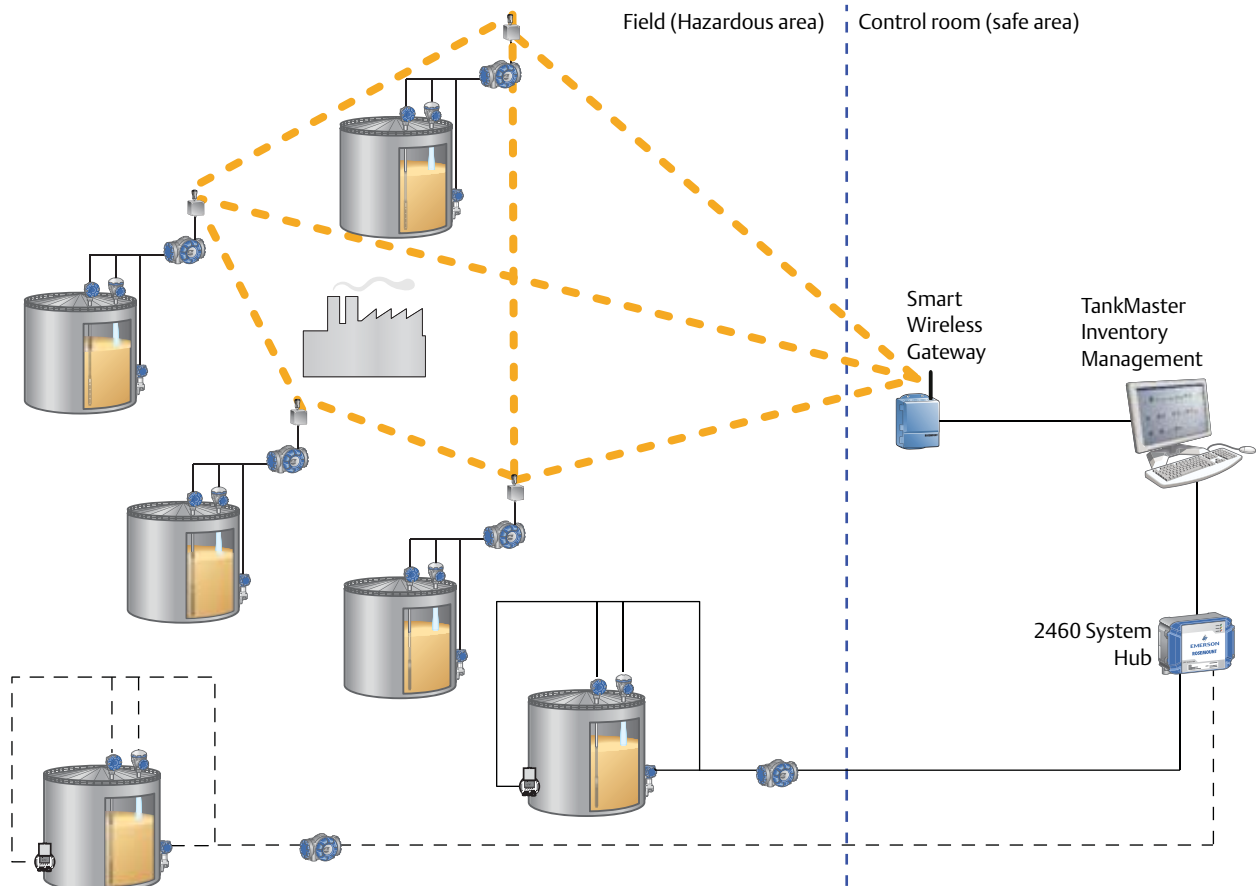

Improve system reliability with redundancy

Rosemount Tank Gauging System supports several redundancy designs, allowing two identical devices for critical operations.

Redundancy can be utilized for some or all equipment, from the control room to the field devices:

- Two TankMaster PC:s – both active and separately asking for data, or one primary active and the secondary in hot standby backup mode.
- Two System Hubs – the primary unit is active, the other is in backup mode. A control signal is sent between the two units.

If the backup unit is not receiving it, or if the primary unit is not working properly, a failure message is sent to TankMaster (or a DCS system), and the backup unit is activated.

- Two Tank Hubs – enables two separate Tankbuses on the same tank.
- Tank Device Redundancy – dual level measurement devices (e.g. two 5900 Series gauges or a 5900S 2-in-1), dual temperature transmitters with associated sensors etc.

See illustration below for a fully redundant system.

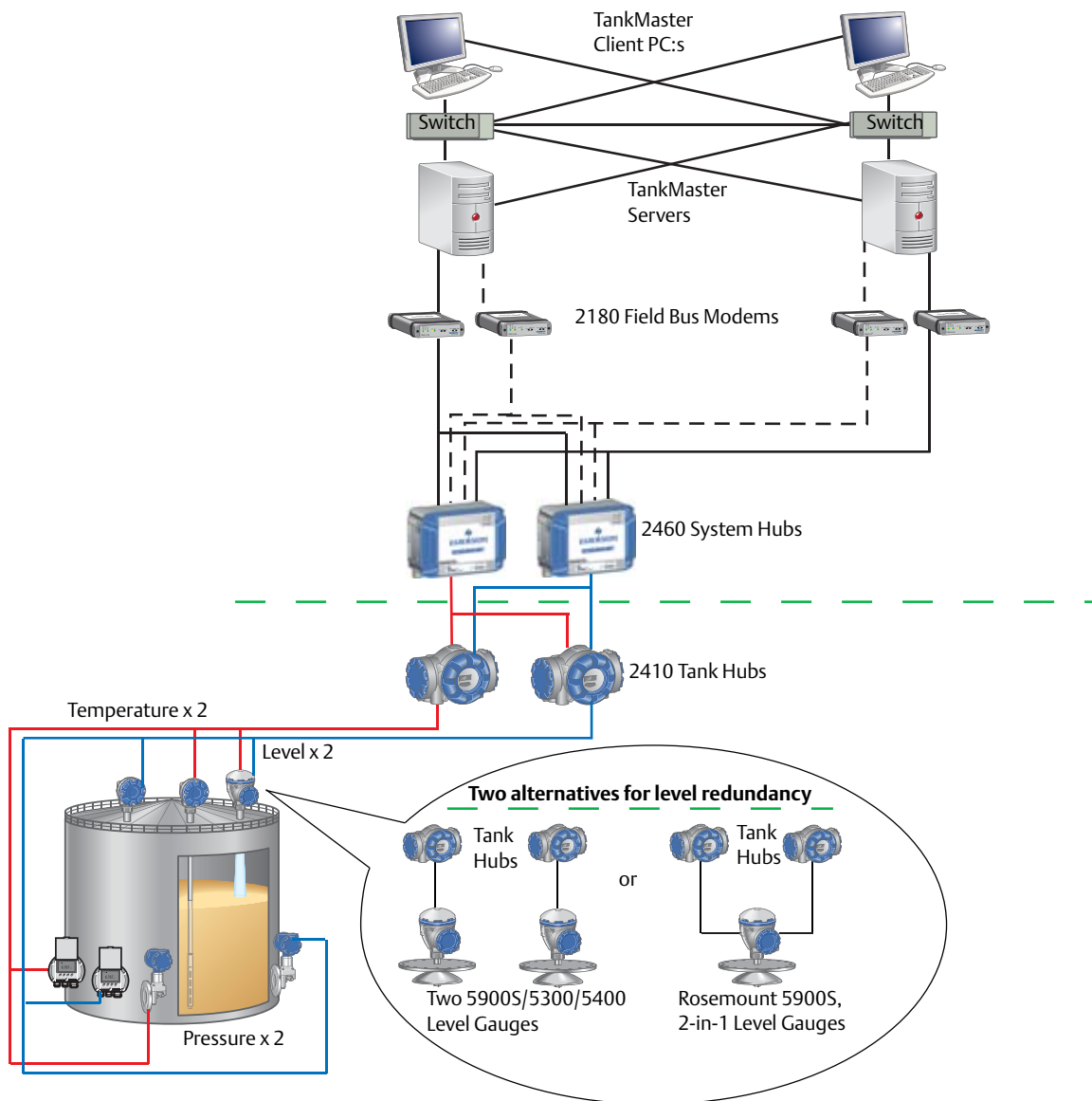

Emulation enables flexible system configuration

Rosemount 2410 Tank Hub and 2460 System Hub support emulation of field devices from other vendors.

In addition the 2460 hub enables exchange of an existing control room operator system to Rosemount TankMaster Inventory Management Software.

TankMaster allows configuration of the emulated field devices. Moreover this software is capable of sending servo commands.

By using the Rosemount 2410 for tanks equipped with other vendor level devices, you can add Rosemount 2240S with multiple spot temperature sensors and benefit from getting more measurement data integrated in the system.

The 2410 Tank Hub also adds wireless capability to the emulated devices, either for primary communication or to achieve redundant communication.

Wireless communication enables previously stranded data and diagnostics to be included in the automated tank gauging system.

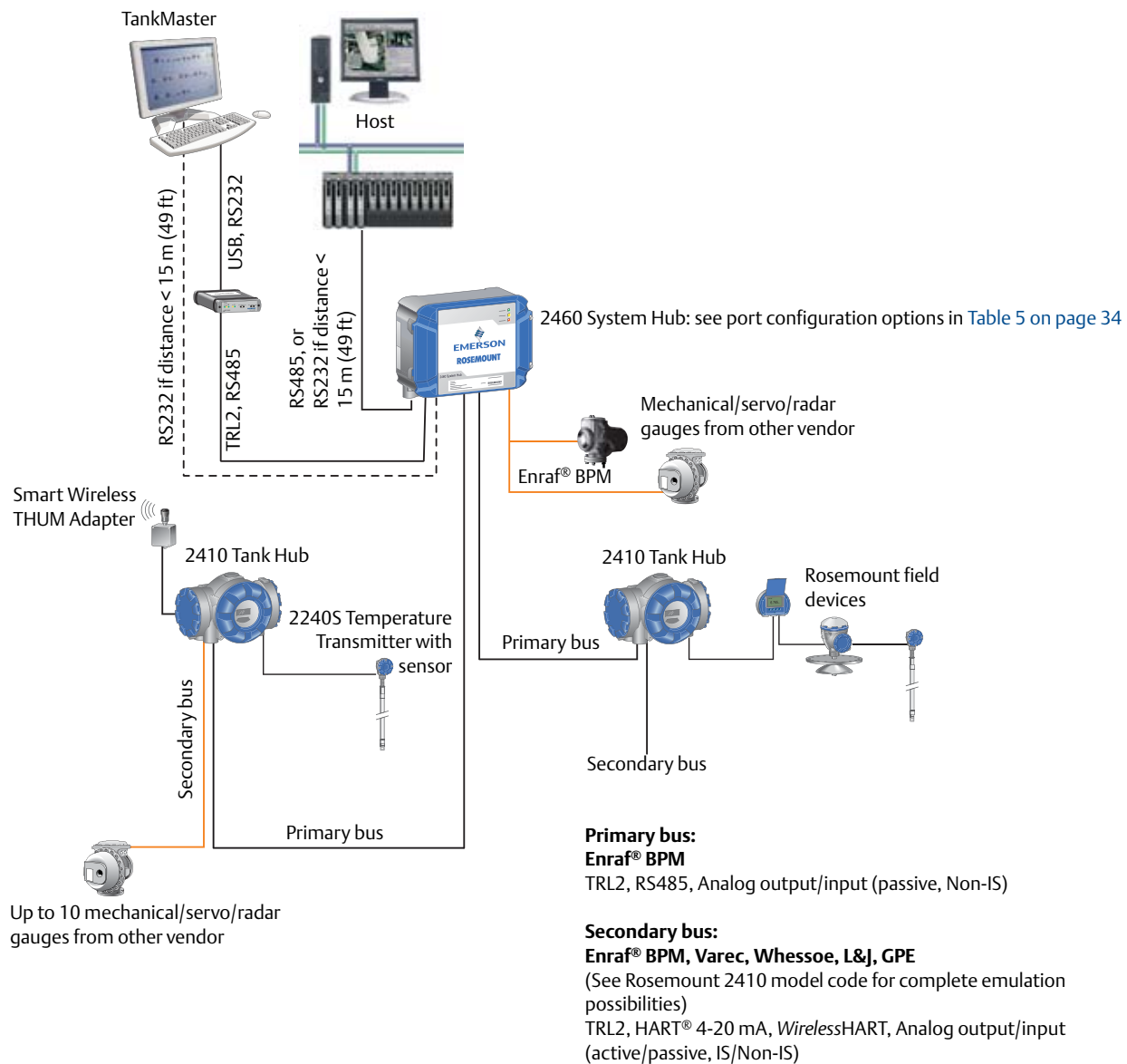

Operational control with 5300- or 5400 system configuration

A 5300- or 5400 system configuration is a cost efficient alternative for non-inventory grade operational control at tank terminals, as well as applications in the biofuels industry, chemical plants etc. This configuration is a good choice for medium accuracy applications. For level measurements, Rosemount 5300 (guided wave radar) or 5400 (non-contacting radar) is used.

For temperature measurements, the Rosemount 644 Temperature Transmitter with a Rosemount 65 or 68 Single Point Temperature Sensor is used. The 2240S Temperature Transmitter is an even better alternative if more than one temperature element is required. All values are transferred to the TankMaster WinView tank management software.

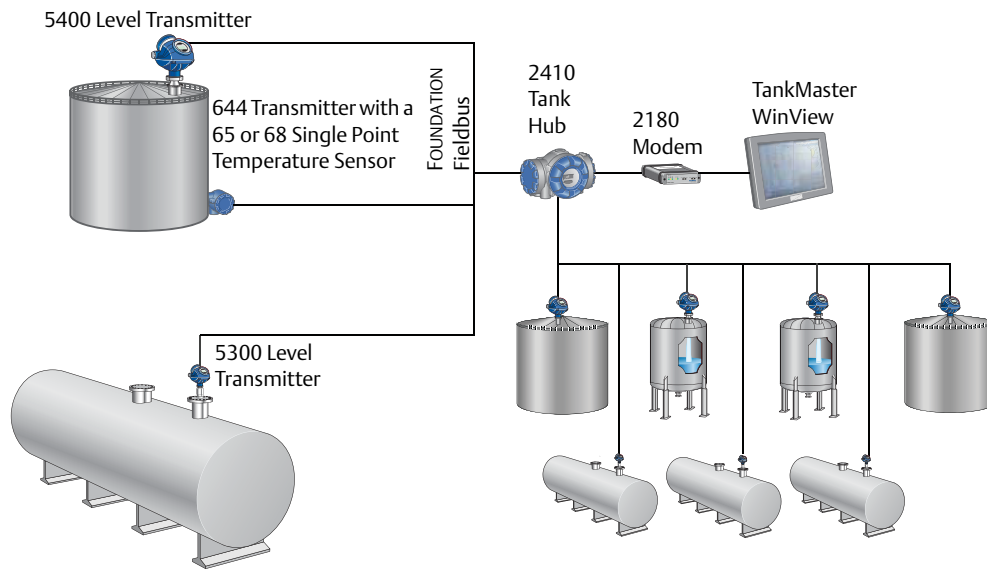

Specifications

System key performance specifications

Rosemount Tank Gauging System meets or exceeds requirements specified in industry relevant standards e.g. API MPMS Ch 7.3, Ch 3.1B and Ch 12.1.1, ISO 4266 and OIML R85.

Level measurement

Instrument accuracy 5900S

±0.5 mm (0.02 in.)

Instrument accuracy 5900C

±3 mm (0.12 in.)

Temperature stability of gauge

Typically <±0.5 mm (0.02 in.) in -40 to +70 °C (-40 to +158 °F)

Update time of gauge

New measurement every 0.3 s

Update time for wireless systems

Depends on number of hops to gateway. Fastest update rate <8 s requires devices with direct communication to the gateway.

Repeatability

0.2 mm (0.008 in.)

Maximum level rate

Up to 200 mm/s

5900S fulfills OIML R85:2008 custody transfer requirements

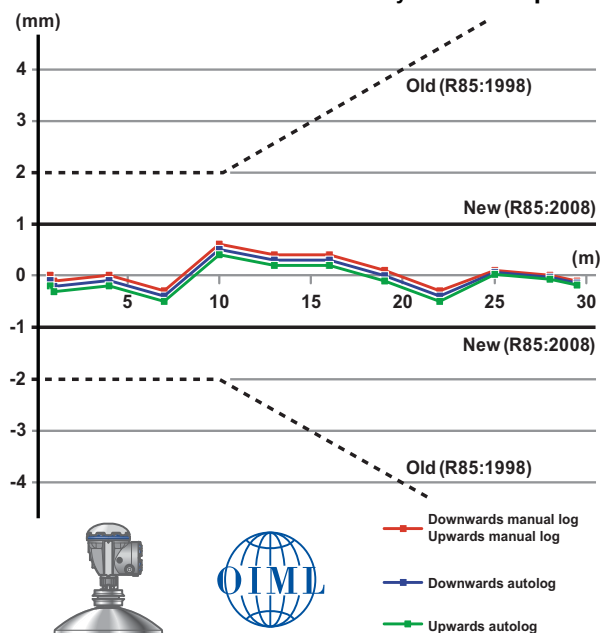

Temperature measurement

2240S Multi-input Temperature Transmitter

Temperature conversion accuracy

0.05 °C (0.09 °F) over measuring range and ambient temperature 20 °C (68 °F)

Ambient temperature effect

±0.05 °C (0.09 °F)

Measuring range

-200 to 250 °C (-328 to 482 °F) for Pt-100

Resolution

±0.1 °C (0.1 °F) according to API chapter 7 and 12

Update time

4 s

Temperature sensor calibration

Deviations deriving from the Pt-100 elements are repeatable and can be eliminated with a unique manufacturing calibration procedure, where the Callendar – Van Dusen equation is used. Calibration can be done with 4-wire sensor elements. The whole process is computer controlled and up to 16 elements in each sensor are automatically calibrated at the same time.

Sensor element type

3- or 4-wire Pt-100 spot elements according to IEC/EN 60751.

Number of elements per sensor

1-16

Table 1. Temperature Accuracy for Rosemount 565 or 765 Temperature Sensors

	Cable 20 m ⁽¹⁾	Pt-100 [40 °C (104 °F)]	Pt-100 [80 °C (176 °F)]	Total sensor accuracy [0-80 °C (32-176 °F)] ⁽²⁾
3-wire connection, 1/6 DIN B	± 0.24 °C (± 0.432 °F)	± 0.13 °C (± 0.234 °F)	± 0.21 °C (± 0.378 °F)	± 0.32 °C (± 0.576 °F)
4-wire connection, 1/6 DIN B	± 0.001 °C (± 0.002 °F)	± 0.13 °C (± 0.234 °F)	± 0.21 °C (± 0.378 °F)	± 0.21 °C (± 0.378 °F)
4-wire connection, 1/10 DIN B	± 0.001 °C (± 0.002 °F)	± 0.11 °C (± 0.198 °F)	± 0.19 °C (± 0.342 °F)	± 0.19 °C (± 0.342 °F)
4-wire connection, calibrated	± 0.001 °C (± 0.002 °F)	± 0.025 °C (± 0.045 °F)	± 0.025 °C (± 0.045 °F)	± 0.025 °C (± 0.045 °F)

1. Common return wiring.
2. Root Mean Square values for wiring error and platinum element error at 80 °C (176 °F).

Table 2. Net Standard Volume (NSV) Uncertainty from Temperature Sensors in a 20 m (66 ft) Diameter Tank at a Level of 18.5 m (60.7 ft)

	Total accuracy [0-80 °C (32-176 °F)]	NSV uncertainty in a 30 m (98 ft) tank and a level at 18.5 m (60.7 ft)
3-wire connection, 1/6 DIN B	± 0.32 °C (± 0.576 °F)	± 3.5 m ³ (± 22.0 bbl)
4-wire connection, 1/6 DIN B	± 0.21 °C (± 0.378 °F)	± 2.3 m ³ (± 14.5 bbl)
4-wire connection, 1/10 DIN B	± 0.19 °C (± 0.342 °F)	± 2.1 m ³ (± 13.2 bbl)
4-wire connection, calibrated	± 0.025 °C (± 0.045 °F)	± 0.25 m ³ (± 1.6 bbl)

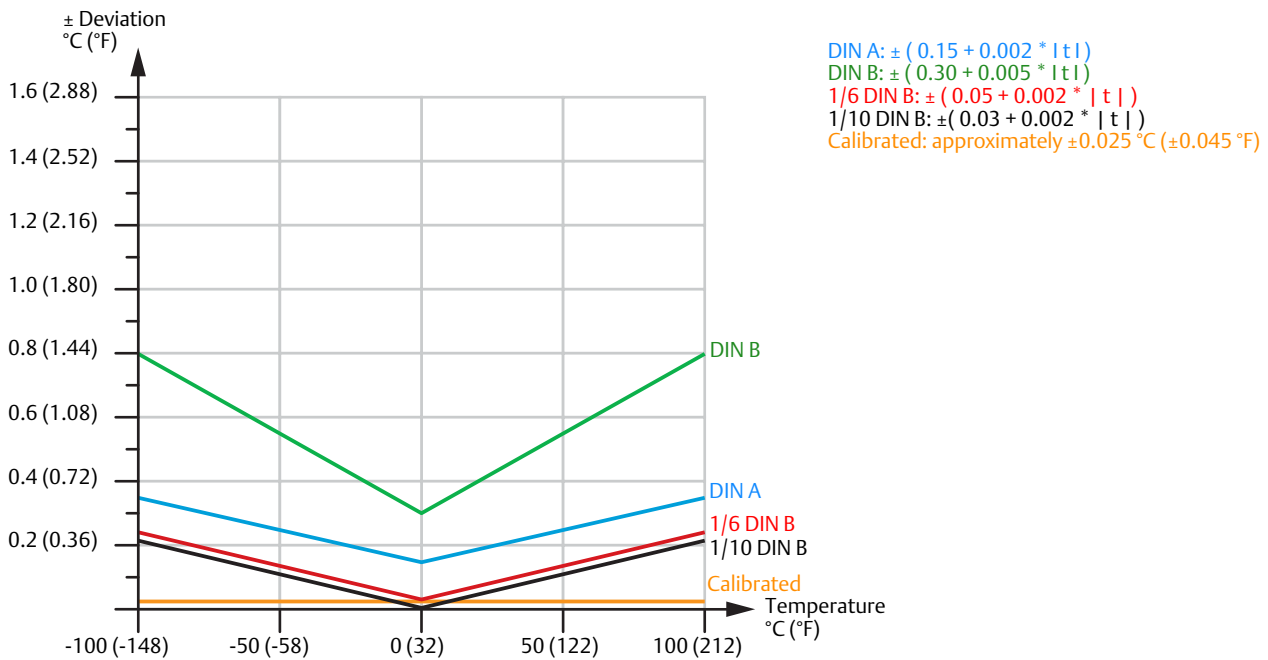

Comparison between DIN A and DIN B according to the standard and 1/6 and 1/10 of DIN B delivered by Emerson.

Volume uncertainty comparison

The uncertainty of the calculated net volume depends not only on the accuracy of the devices, but also on the application. Below is an example to compare the difference between typical 5900S, 5900C and 5300/5400 configurations.

- Crude oil, 887 kg/m³ density at 20 °C (68 °F) product temperature
- Tank height: 10 m (33 ft)
- Tank diameter: 15 m (49 ft)
- Number of inventories per year: 12
- Number of batch transfers per year: 24
- Ambient temperature: 5 to 35 °C (41 to 95 °F)

Under these conditions, the typical measurement accuracy is:

- 5900S: ±1 mm (0.04 in.), 0.17 °C (0.30 °F)
- 5900C: ±3 mm (0.12 in.), 0.17 °C (0.30 °F)
- 5300/5400: ±10 mm (0.4 in.), 1.2 °C (2.2 °F)⁽¹⁾
- A traditional mechanical tape and float system: ±25 mm (1 in.), 1.5 °C (2.7 °F)⁽¹⁾

According to API Manual of Petroleum Measurement Standards, chapter 11: considering both level and temperature uncertainty, the total volume uncertainty in liters is shown in Table 3.

Consequently the 5900S configuration reduces volume uncertainty in this example with approximately 90% compared to the 5300/5400 system configuration.

Moreover, a 5300/5400 system configuration reduces the volume uncertainty with approximately 50% compared to a mechanical tape and float system.

Although calculated for a specific application, this is a representative value for any hydrocarbon storage tank, independent of size.

Table 3. Volume Uncertainty Comparison in Liters (Barrels)

	5900S	5900C	5300/5400	Tape & Float
Per inventory⁽¹⁾	263 (1.7)	648 (4.1)	2229 (14.0)	4732 (29.8)
Per batch⁽¹⁾	304 (1.9)	891 (5.6)	2778 (17.5)	6429 (40.4)
Total uncertainty per year⁽¹⁾⁽²⁾	2403 (15.1)	6615 (41.6)	21332 (134.2)	47891 (301.2)

1. Statistical error, root mean square value (RMS).
2. 12 inventories and 24 batches.

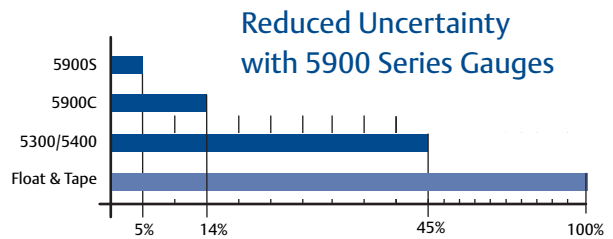

Pressure measurement

Reference accuracy 3051S

Coplanar pressure transmitter

Up to ±0.025% of span for ultra version, up to ±0.035% of span for classic version.

Liquid level pressure transmitter

Up to ±0.055% of span for ultra version, up to ±0.065% of span for classic version.

1. Low estimate. According to API chapter 7: In large tanks not thoroughly mixed, vertical temperature differences of as much as 3 °C (5.4 °F) are normal, and differences of 5 °C (9.0 °F) are common.

System design specifications

System layout

Communication on the self-configuring Tankbus connected to the 2410 Tank Hub is based on FOUNDATION Fieldbus. It is also possible to connect previous Rosemount tank gauging devices to the system via Modbus, integrate a wireless system and a system from another vendor (see Table 5).

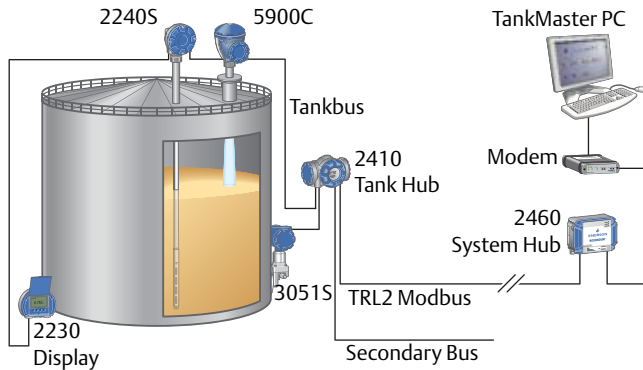

Some data to help customize the system:

- The 2410 Tank Hub delivers 250 mA to the Tankbus. The number of tanks and units connected to the Tank Hub depends on which field devices are connected, and their power consumption. Current requirement per field device is listed in Table 4.
- One 2410 Tank Hub per tank is recommended for a 5900 Series system configuration.
- 2410 Tank Hub supports maximum 5 tanks for a 5300- or 5400 system configuration.
- Minimum voltage supply to the devices is 9 V.

Table 4. Power Budget

Field device	Current consumption (9V)
5900 Series Radar Level Gauge	50 mA
5900S Radar Level Gauge, 2-in-1	100 mA
5300 or 5400 Series Radar Level Transmitter	21 mA
2230 Graphical Field Display	30 mA
2240S Multi-input Temperature Transmitter	30 mA including temperature sensors
644 Temperature Transmitter	11 mA
3051S or 2051 Pressure Transmitter	18 mA

Examples:

250 mA from the 2410 Tank Hub supplies power to:

One tank with:

- One 5900S 2-in-1 Radar Level Gauge
- One 2240S Multi-input Temperature Transmitter with sensor
- Two 2230 Displays
- Two 3051S Pressure Transmitters

Five tanks with:

- Five 5300 or 5400 Radar Level Transmitters
- Five 644 Temperature Transmitters with sensors
- One 2230 Display

Table 5. 2460 System Hub Port Configuration

Port	1	2	3	4	5	6	7	8
Type	Field Port	Field Port	Field Port	Field Port	Field/Host Port	Field/Host Port	Host Port	Host Port
Interface	TRL2, RS485, Enraf BPM	TRL2, RS485, Enraf BPM	TRL2, RS485, Enraf BPM	TRL2, RS485, Enraf BPM	Field Port: TRL2, RS485, Enraf BPM Host Port: TRL2, RS485	Field Port: TRL2, RS485, Enraf BPM Host Port: TRL2, RS485	TRL2, RS485, RS232	TRL2, RS485, RS232
Protocol	Modbus, Enraf GPU	Modbus, Enraf GPU	Modbus, Enraf GPU	Modbus, Enraf GPU	Field Port: Modbus, Enraf GPU Host Port: Modbus	Field Port: Modbus, Enraf GPU Host Port: Modbus	Modbus	Modbus

Tankbus cable requirements

Recommended cabling is shielded twisted pairs, 0.75 mm² (AWG 18). Other possibilities are shielded twisted pairs, 0.5-1.5 mm² (AWG 22-16). Tankbus cabling must fulfill FISCO cable and installation requirements and be approved for use in minimum 85 °C (185 °F).

FISCO (Fieldbus Intrinsically Safe Concept)

The following cable characteristics are specified for FISCO according to IEC 60079-27.

Table 6. FISCO Cable Characteristics

Parameter	Value
Loop resistance	15 to 150 Ω/km
Loop inductance	0.4 to 1 mH/km
Capacitance	45 to 200 nF/km
Maximum length of each spur ⁽¹⁾ cable	60 m (197 ft) in gas Group IIC
Maximum length of each trunk ⁽²⁾ cable	1000 m (0.60 miles) in gas Group IIC, and 1900 m (1.18 miles) in gas Group IIB

1. The spur is an unterminated part of the network. It is allowed to have an up to 60 m (197 ft) long spur. For longer distances, an alternative network configuration should be considered.
2. The trunk is the part of the network which has terminators at both ends. In the system, a trunk can be the part of the network between the Tank Hub and a segment coupler or the last device in a daisy-chain configuration.

Re-use of existing cabling

It is recommended to install new Tankbus cabling according to the specification above. In most cases it is possible to re-use the existing cabling, if compliant with FISCO requirements.

Examples

Typical characteristics for such a cable is:

- 0.75 mm² (AWG 18)
- 42 Ω/km (loop resistance)
- 115 nF/km
- 0.65 mH/km

The following examples show the allowed cabling distances for different system configurations. It is assumed that the devices are installed at the end of the cabling for a full load scenario. In reality that is not the case, which is why the allowed distances might be longer.

Maximum Distance with Maximum Power Usage for a 5900S Configuration:

The Rosemount 2410 Tank Hub can deliver 250 mA (12.5 VDC) to the devices on the tank. A voltage drop of 3.5 V is allowed. This means that the total worst case cable resistance can be up to 14 Ω (3.5/0.250). The maximum cable length is 333 m (1092 ft).

Maximum Distance with Typical Power Usage for a 5900S Configuration:

A more typical current value is 128 mA for a tank equipped with one 5900S gauge, one 2230 display, one 2240S temperature transmitter, and one 3051S pressure transmitter. In this case a 650 m (2130 ft) long cable can be used.

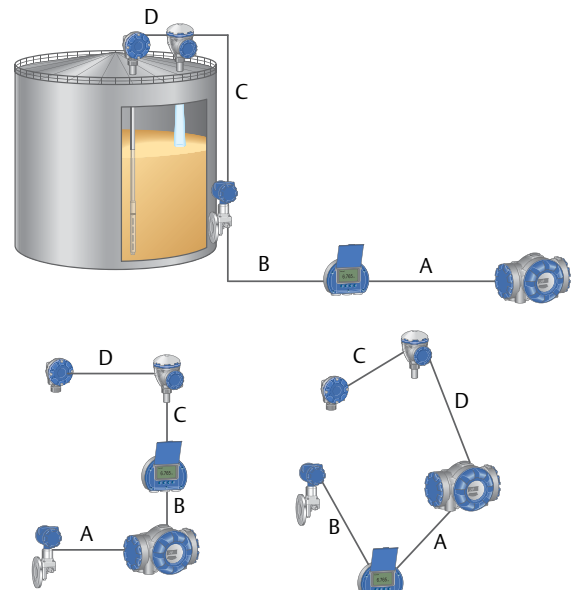

Total cable distance A+B+C+D must not exceed the values in Table 7.

Table 7. Maximum Cabling Distance for a 5900 Series Configuration

Cable diameter	Loop resistance	Maximum cabling distance from power source (2410) to all devices on the tank		
		with maximum power usage of 250 mA. Distance in m (ft)	with typical power usage of 128 mA for 5900 Series, 2240S, 2230, 3051S. Distance in m (ft)	with typical power usage of 178 mA for 5900S 2-in-1, 2240S, 2230, 3051S. Distance in m (ft)
20 AWG (0.5 mm ²)	66 Ω/km	212 (695)	414 (1358)	298 (978)
18 AWG (0.75 mm ²)	42 Ω/km	333 (1092)	651 (2136)	468 (1535)
17 AWG (1.0 mm ²)	33 Ω/km	424 (1391)	829 (2720)	596 (1955)
16 AWG (1.5 mm ²)	26 Ω/km	538 (1765)	1000 (3281)	756 (2480)

Maximum Distance with Typical Power Usage for a 5900S 2-in-1 Configuration:

If the tank instrumentation is the same as in the previous example, but instead is equipped with a 5900S 2-in-1 gauge, the typical current value is 178 mA. The cable can then be 468 m (1535 ft).

Table 7 is a guide to how long cables are allowed for a 5900 Series system configuration with some common cable types.

Maximum Distance with Typical Power Usage for a 5300/5400 Configuration:

For a tank equipped with one 5300 or 5400 Transmitter, and one 644 Temperature Transmitter, the typical current value is 32 mA. This means the cable can be up to 2604 m (8543 ft).

It is possible to have five such 5300- or 5400-based tanks connected to one 2410 Tank Hub, if the total cable length is not exceeded.

Table 8 is a guide to how long cables are allowed for a 5300 or 5400 system configuration with some common cable types.

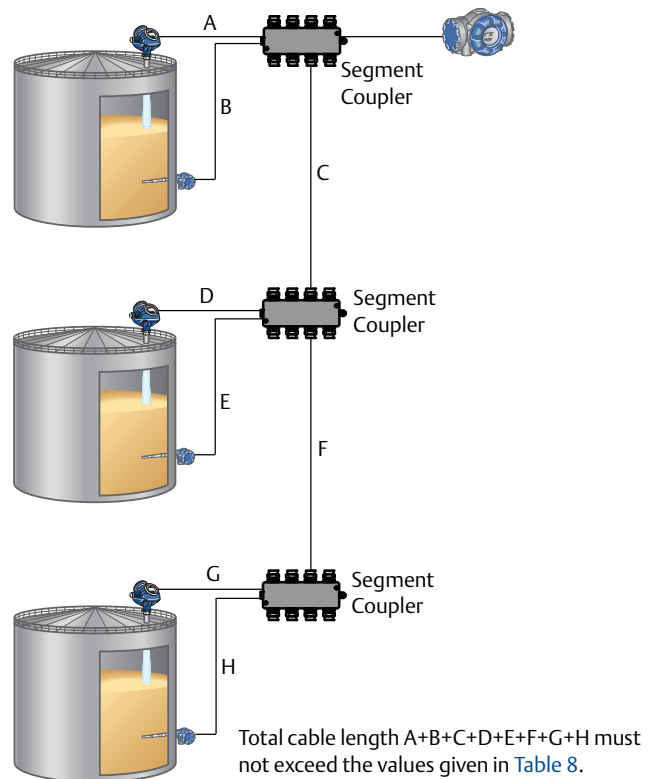

Table 8. Maximum Cabling Distance for a 5300/5400 Configuration

Cable diameter	Loop resistance	Maximum total cable length from power source (2410) to all devices on the tank, m (ft) with typical power usage of 32 mA per tank with 5300/5400 and 644				
		Five tanks Distance in m (ft)	Four tanks Distance in m (ft)	Three tanks Distance in m (ft)	Two tanks Distance in m (ft)	One tank Distance in m (ft)
20 AWG (0.5 mm ²)	66 Ω/km	331 (1085)	414 (1358)	552 (1811)	828 (2716)	1000 (3281)
18 AWG (0.75 mm ²)	42 Ω/km	520 (1706)	651 (2135)	868 (2847)	1000 (3281)	1000 (3281)
17 AWG (1.0 mm ²)	33 Ω/km	662 (2171)	828 (2716)	1000 (3281)	1000 (3281)	1000 (3281)
16 AWG (1.5 mm ²)	26 Ω/km	841 (2759)	1000 (3281)	1000 (3281)	1000 (3281)	1000 (3281)

TRL2 field bus cable recommendations

In a Rosemount Tank Gauging System, the 2410 Tank Hub communicates with a 2460 System Hub using the TRL2 Modbus protocol.

The TRL2 field bus requires twisted and shielded pair wiring with a minimum area of 0.50 mm² (AWG 20 or similar).

The maximum length of the TRL2 field bus is approximately 4 km (2.5 miles). The TRL2 field bus can normally use existing cables in the tank area.

Typical Tankbus wiring in a 5900 Series system configuration

Available installation configurations enable easy and cost efficient cabling. Rosemount Tank Gauging System has a daisy chain feature for convenient wiring of the Tankbus.

The devices in a 5900 Series system configuration have an on/off selectable built-in bus terminator (the last device on the bus must be terminated).

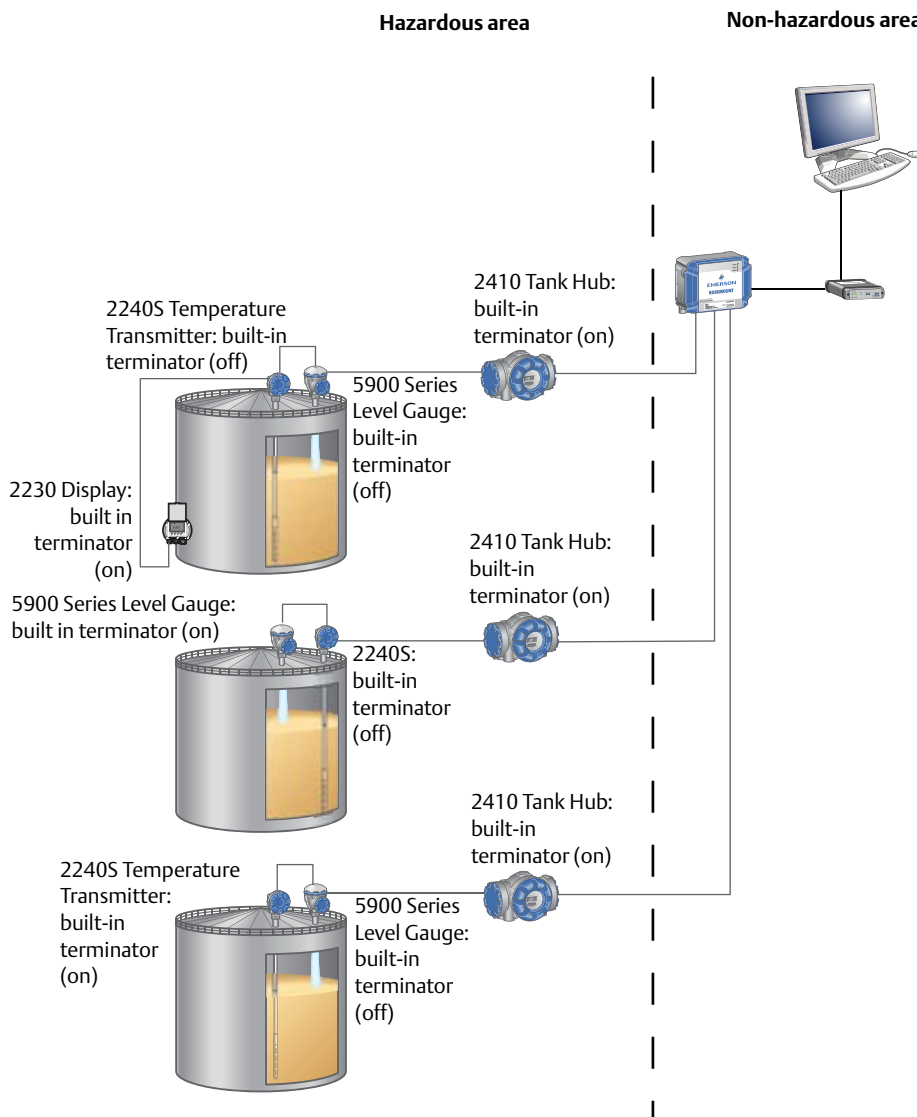

No external segment couplers or bus terminators are needed when the last device on the bus is a 5900 Series gauge, a 2240S or a 2230.

System certifications

Refer to each device PDS/Reference manual for details.

Accuracy/legal metrological approvals

- OIML R 85 edition 2008
- Australia, NMI
- Belgium, BMS
- China, CPA
- Croatia, Custody Transfer Certificate
- Czech Republic, CMI
- Estonia, TJA
- France, LNE
- Germany, PTB Eich
- India, W&M
- Indonesia, MIGAS
- Italy, Ministero dello Sviluppo Economico
- Kazakhstan, GOST
- Malaysia, SIRIM
- Norway, Justervesenet
- Poland, GUM
- Portugal, IPQ
- Russia, GOST
- Serbia, Custody Transfer Certificate
- Switzerland, METAS
- The Netherlands, NMI

Hazardous location certifications

- ATEX
- IECEx
- FM-US
- FM-Canada
- Inmetro (Brazil)
- KC (South Korea)
- EAC/GOST (Russia, Belarus, Kazakhstan)
- NEPSI (China)
- PESO (India)
- TIIS (Japan)

Safety/overflow protection approvals

- IEC 61508 certified SIL 2 and SIL 3 capable (depending on device)
- TÜV/DIBt WHG for overflow protection (Germany)
- SVTI for overflow protection (Switzerland)
- Vlare II for overflow protection (Belgium)

Appendix A

Technical documentation for Rosemount Tank Gauging System

Product data sheets

- [5900S Radar Level Gauge \(00813-0100-5900\)](#)
- [5900C Radar Level Gauge \(00813-0100-5901\)](#)
- [5300 Radar Level Transmitter \(00813-0100-4530\)](#)
- [5400 Radar Level Transmitter \(00813-0100-4026\)](#)
- [2240S Multi-input Temperature Transmitter \(00813-0100-2240\)](#)
- [565/566/765 Multiple Spot Temperature and Water Level Sensors \(00813-0100-5565\)](#)
- [644/65/68 Single Point Temperature Measurement for tank gauging systems \(00813-0100-5102\)](#)
- [3051S Pressure Transmitter for tank gauging systems \(00813-0300-4801\)](#)
- [2230 Graphical Field Display \(00813-0100-2230\)](#)
- [2130 Enhanced Temperature Vibrating Fork Liquid Level Switch \(00813-0100-4130\)](#)
- [2160 WirelessHART Vibrating Fork Liquid Level Switch \(00813-0100-4160\)](#)
- [2410 Tank Hub \(00813-0100-2410\)](#)
- [2460 System Hub \(00813-0100-2460\)](#)
- [Tank Gauging Accessories \(00813-0100-5101\)](#)
- [Control Cabinets \(00813-0100-1860\)](#)
- [Smart Wireless Gateway 1420 \(00813-0200-4420\)](#)
- [Smart Wireless Gateway 1410 \(00813-0200-4410\)](#)
- [Smart Wireless THUM Adapter \(00813-0100-4075\)](#)
- [TankMaster Inventory Management Software \(00813-0100-5110\)](#)

Reference manuals

- [5900S Radar Level Gauge \(00809-0100-5900\)](#)
- [5900C Radar Level Gauge \(00809-0100-5901\)](#)
- [5300 Radar Level Transmitter \(00809-0100-4530\)](#)
- [5400 Radar Level Transmitter \(00809-0100-4026\)](#)
- [2240S Multi-input Temperature Transmitter \(00809-0100-2240\)](#)
- [644 Temperature Transmitter with FOUNDATION Fieldbus \(00809-0400-4728\)](#)
- [3051S Series Pressure Transmitter Family with FOUNDATION Fieldbus Protocol \(00809-0200-4801\)](#)
- [2230 Graphical Field Display \(00809-0100-2230\)](#)
- [2130 Enhanced Temperature Vibrating Fork Liquid Level Switch \(00809-0100-4130\)](#)
- [2160 WirelessHART Vibrating Fork Liquid Level Switch \(00809-0100-4160\)](#)
- [2410 Tank Hub \(00809-0100-2410\)](#)
- [2460 System Hub \(00809-0100-2460\)](#)
- [Smart Wireless Gateway 1420 \(00809-0200-4420\)](#)
- [Smart Wireless Gateway 1410 \(00809-0200-4410\)](#)
- [Smart Wireless THUM Adapter \(00809-0100-4075\)](#)
- [Tank Gauging System Configuration \(00809-0300-5100\)](#)
- [TankMaster WinOpi \(303028EN\)](#)
- [TankMaster WinView \(303043EN\)](#)
- [Wireless Tank Gauging System \(00809-0100-5200\)](#)

Appendix B

When to use a 5900 Series or a 5300/5400 system configuration

For more information, see “Appendix C” on page 42.

Devices	5900 Series system configuration: The 5900S gauge is recommended for high performance solutions for custody transfer, inventory control, oil/product movement & operations, overfill prevention & leak detection	5300- or 5400 system configuration: For oil/product movement & operations and overfill prevention
Level, Temperature, and Inventory management	5900 Series gauge, 2240S with 565/566/ 765 multiple spot temperature sensor and TankMaster WinOpi	5300 and/or 5400 transmitter, 644 with 65 or 68 single spot temperature sensor, and TankMaster WinView
Features		
Instrument accuracy		
Level	5900S: ± 0.5 mm (0.02 in.) ⁽¹⁾ 5900C: ± 3 mm (0.12 in.) ⁽¹⁾	± 3 mm (0.12 in.) ⁽¹⁾
Temperature	Transmitter: ± 0.1 °C (0.18 °F) Sensors: ± 0.07 °C (0.13 °F)	Transmitter: ± 0.22 °C (0.40 °F) Sensor: ± 0.41 °C (0.74 °F)
Typical system performance		
Level	5900S: ± 1.0 mm (0.04 in.) 5900C: ± 3.0 mm (0.12 in.)	± 10 mm (0.4 in.) ⁽²⁾
Temperature⁽³⁾	± 0.17 °C (0.31 °F)	± 1.2 °C (2.16 °F) ⁽⁴⁾
Volume Uncertainty	5900S: 90% reduction compared with a 5300/5400 configuration	
Safety		
SIL 3	Yes, certified (5900S)	No
SIL 2	Yes, certified	Yes, FMEDA ⁽⁵⁾
Overfill prevention approvals	Yes, TÜV/DIBt WHG and other national approvals ⁽⁶⁾	Yes, TÜV/DIBt WHG and national approvals
Proof testing	Yes, extended & certified (TankMaster WinOpi)	Yes
Relay outputs for direct control	Yes	No
System output		
Spot temperature	Yes	Yes
Average temperature	Yes	No
Free water level	Yes	No
Pressure	Yes	No
Total observed volume (TOV)	Yes	Yes
Gross observed volume (GOV)	Yes	No
Gross standard volume (GSV)⁽⁷⁾	Yes	No
Net standard volume (NSV)⁽⁷⁾	Yes	No
Density	Yes	No
Mass	Yes	No
Alarm handling	Yes	Yes
Batch handling feature	Yes	No
On-line density	Yes	No
Scheduled on-line reports	Yes	No
Legal metrological approvals		
OIML R85	Yes (5900S)	No
NMI, PTB	Yes (5900S)	No
Other national approvals	Yes (5900S). See page 38	No
Redundancy		
2-in-1 radar gauge	Yes (5900S)	No
Communication		
Emulation	Yes	Yes
Wireless field network	Yes	Yes

1. At reference conditions.
2. Accuracy in temperature range 5 to 30 °C (41 to 86 °F).
3. Summary of transmitter and sensor values for total accuracy at 20 °C (68 °F).
4. Including ± 0.6 °C (1.08 °F) in stratification effect.
5. SIL 2 requires the 4-20 mA HART version of Rosemount 5300 or 5400. 5400 is suitable for SIL 2 applications on basis of prior use according to IEC 61511-1.
6. Requires a Rosemount 2410 Tank Hub with applicable safety output.
7. According to API/ISO.

Appendix C

Radar level device selection

See “When to use a 5900 Series or a 5300/5400 system configuration” on page 41 for more guidance.

Below is a guideline to which radar level device and antenna/probe to use for various tanks and applications. In general, use 5900S for custody transfer and inventory control, which require highest accuracy and reliability.

Tank and Application	Recommended	Second Choice	Alternative Choice
Fixed Roof Tanks			
18 in. or larger nozzle, no disturbing objects in tank	5900S with parabolic antenna	5900C with parabolic antenna	5402 with 4-in. cone antenna or 5301 with flexible twin ⁽¹⁾ /single lead probe
8 in. to 17 in. nozzle, no disturbing objects in tank	5900S with horn antenna	5900C with horn antenna	5402 with 4-in. cone antenna or 5301 with flexible twin ⁽¹⁾ /single ⁽²⁾ lead probe
4-6 in. nozzle, no disturbing objects in tank	5900C with cone antenna	5402 with 4-in cone antenna	5301 with flexible single lead probe
2-3 in. nozzle, no disturbing objects in tank	5900C with 1-in or 2-in still-pipe antenna	5301 with flexible single lead probe	5402 with 2 or 3-in cone antenna
Objects in tank	5900S with parabolic antenna	5900C with parabolic antenna	5301 with coaxial ⁽¹⁾⁽³⁾ , flexible twin ⁽¹⁾ or single lead probe or 5402 with cone antenna
5-12 in. still-pipe	5900S with still-pipe array antenna	5900C with still-pipe array antenna	5301 with flexible single lead probe and a centering disk
2-4 in. still-pipe measurement	5900C with 1-in or 2-in still-pipe antenna	5900C with cone antenna	5301 with flexible single lead probe and centering disks ⁽⁴⁾
Floating Roof Tanks			
5-12 in. still-pipe	5900S with still-pipe array antenna	5900C with still-pipe array antenna	5301 with flexible single lead probe and a centering disk
Measurement towards tank roof	5900S with parabolic antenna	5900C with parabolic antenna	5402 with 4-in. cone antenna
Bullet/Sphere Shaped Tanks			
Pressurized LPG sphere, > 6 m (20 ft)	5900S with LPG/LNG antenna	5900C with LPG/LNG antenna or 2-in still-pipe antenna	5301 with flexible twin lead probe ⁽¹⁾ and centering disks
Pressurized LPG bullet, < 6 m (20 ft)	5900S with LPG/LNG antenna	5900C with LPG/LNG antenna or 1-in ⁽⁵⁾ or 2-in still-pipe antenna	5301 with coaxial probe ⁽¹⁾ or flexible twin lead probe
Other bullet tanks (e.g. additive tanks) < 6 m (20 ft)	5900S with LPG/LNG antenna	5900C with 1-in or 2-in still-pipe antenna	5301 with coaxial probe ⁽¹⁾
Water Interface Measurement			
Upper Liquid Level + Free Water Interface Level	5900S and a 765 water level sensor ⁽⁶⁾	5900C and a 765 water level sensor ⁽⁶⁾	5302 with flexible twin lead ⁽¹⁾⁽⁷⁾ or coaxial ⁽¹⁾⁽³⁾ probe or 5302 with flexible single lead probe ⁽⁸⁾

1. For clean products, with no risk for build-up.
2. Special considerations for 10 in. or larger nozzles. Consult factory.
3. Best alternative choice for measuring distance up to 6 m (20 ft).
4. Maximum 20 m (66 ft). Centering disks required to be placed along the probe, with a separation distance of 5 m (16 ft).
5. Maximum 3 m (10 ft).
6. When the free water interface level is < 1000 mm (3.3 ft).
7. Upper liquid thickness typically up to 25 m (82 ft) for oil/water interface.
8. Upper liquid thickness typically up to 15 m (49 ft) for oil/water interface.

High Performance Bulk Liquid Measurement and Overfill Prevention Solutions

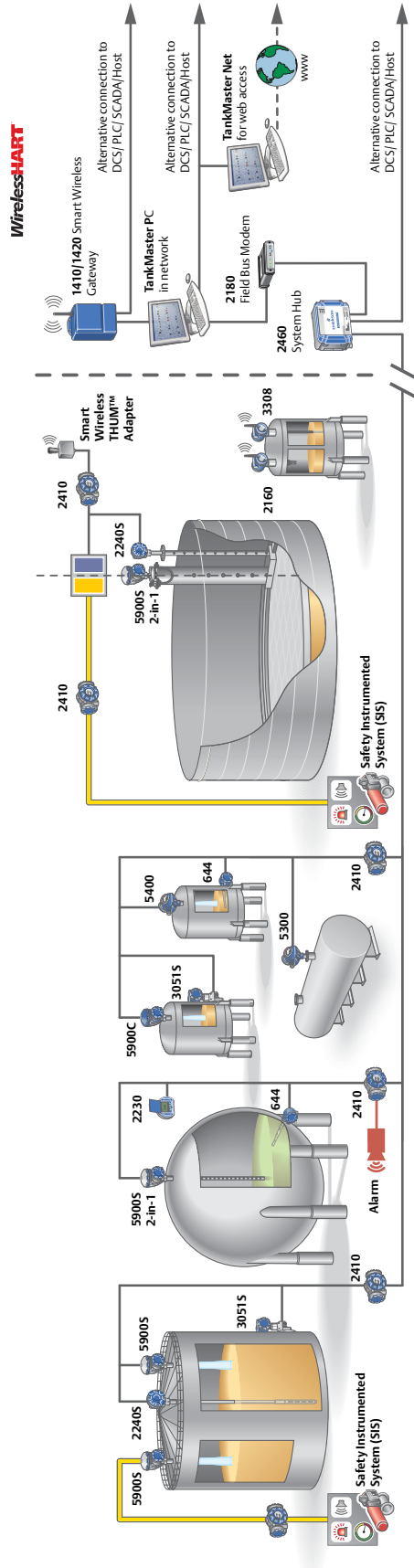

Global Headquarters and Europe Regional Office
Tank Gauging

Emerson Process Management

Box 150
(Visiting address: Layoutvägen 1)
SE-435 23 Mölnlycke
+46 31 337 00 00
+46 31 25 30 22
sales.rtg@emerson.com

North America Regional Office
Tank Gauging

Emerson Process Management

6005 Rogerdale Road
Mail Stop NC 136
Houston, TX 77072, USA
+1 281 988 4000 or +1 800 722 2865
sales.rtg.hou@emerson.com

Latin America Regional Office

Emerson Process Management

1300 Concord Terrace, Suite 400
Sunrise, FL 33323, USA
+1 954 846 5030
+1 954 846 5121
RFQ.RMD-RCC@EmersonProcess.com

Asia Pacific Regional Office

Emerson Process Management Asia Pacific Pte Ltd

1 Pandan Crescent
Singapore 128461
+65 6777 8211
+65 6777 0947
Specialist-OneLevel.RMT-AP@emerson.com

Middle East and Africa Regional Office
Tank Gauging

Emerson Process Management

P.O Box 20048
Manama
Bahrain
+973 1722 6610
+973 1722 7771
rtgmea.sales@emerson.com

 [Linkedin.com/company/Emerson-Process-Management](https://www.linkedin.com/company/Emerson-Process-Management)

 [Twitter.com/Rosemount_News](https://twitter.com/Rosemount_News)

 [Facebook.com/Rosemount](https://www.facebook.com/Rosemount)

 [Youtube.com/user/RosemountMeasurement](https://www.youtube.com/user/RosemountMeasurement)

 [Google.com/+RosemountMeasurement](https://plus.google.com/+RosemountMeasurement)

Standard Terms and Conditions of Sale can be found at:
www.Emerson.com/en-us/pages/Terms-of-Use.aspx
The Emerson logo is a trademark and service mark of Emerson Electric Co.
TankMaster, TankRadar, AMS, THUM, DeltaV, Bettis, Rosemount and
Rosemount logotype are trademarks of Emerson Process Management.
HART, WirelessHART, and FOUNDATION Fieldbus are registered trademarks
of the FieldComm Group.
Enraf is a registered trademark of Honeywell International Inc.
Modbus is a registered trademark of Gould Inc.
Windows is a registered trademark of Microsoft Corporation in the United
States and other countries.
All other marks are the property of their respective owners.
© 2016 Rosemount Inc. All rights reserved.