

Rosemount™ 8782 Slurry Magnetic Flow Meter Transmitter



1 Safety

⚠ WARNING

- Failure to follow these installation guidelines could result in serious injury or death.
- Installation and servicing instructions are for use by qualified personnel only. Do not perform any servicing other than that contained in the operating instructions, unless qualified.
- Potential electrostatic charging hazard: Rosemount Magnetic flow meters ordered with non-standard paint options or non-metallic labels may be subject to electrostatic discharge. To avoid electrostatic charge build-up, do not rub the flow meter with a dry cloth or clean with solvents.
- Verify that the operating environment of the sensor and transmitter is consistent with the appropriate Agency Approval.
- If installed in an explosive atmosphere, verify that the device certification and installation techniques are suitable for that particular environment.
- To prevent ignition of flammable or combustible atmosphere, disconnect power before servicing circuits.
- Explosion hazard: Do not disconnect equipment when a flammable or combustible atmosphere is present.
- Follow national, local, and plant standards to properly earth ground the transmitter and sensor. The earth ground must be separate from the process reference ground.
- Shock hazard: Shut off power before servicing. Do not operate without power compartment cover.

⚠ CAUTION

- In cases where high voltage/high current are present near the meter installation, ensure proper protection methods are followed to prevent stray voltage/current from passing through the meter. Failure to adequately protect the meter could result in damage to the transmitter and lead to meter failure.
- Completely remove all electrical connections from both sensor and transmitter prior to welding on the pipe. For maximum protection of the sensor, consider removing it from the pipeline.

2 Introduction

This document provides basic installation guidelines for the Rosemount 8782 Magnetic Slurry wall-mount transmitter.

- For sensor installation refer to the *Rosemount™ MS Magnetic Slurry Flow Meter Sensor Quick Installation Guide*
- For additional installation information, configuration, maintenance, and troubleshooting, refer to the *Rosemount™ 8782 Magnetic Slurry Flow Meter with HART Protocol Reference Manual*

All user documentation can be found at www.emerson.com. For more contact information see [Emerson Flow customer service](#).

2.1 Return policy

Emerson procedures must be followed when returning equipment. These procedures ensure legal compliance with government transportation agencies and help provide a safe working environment for Emerson employees. Failure to follow Emerson procedures will result in your equipment being refused delivery.

2.2 Emerson Flow customer service

Email:

- Worldwide: flow.support@emerson.com
- Asia-Pacific: APflow.support@emerson.com

Telephone:

North and South America		Europe and Middle East		Asia Pacific	
United States	800 522 6277	U.K.	0870 240 1978	Australia	800 158 727
Canada	+1 303 527 5200	The Netherlands	+31 (0) 704 136 666	New Zealand	099 128 804
Mexico	+41 (0) 41 7686 111	France	0800 917 901	India	800 440 1468
Argentina	+54 11 4837 7000	Germany	0800 182 5347	Pakistan	888 550 2682
Brazil	+55 15 3413 8000	Italy	8008 77334	China	+86 21 2892 9000
Venezuela	+58 26 1731 3446	Central & Eastern	+41 (0) 41 7686 111	Japan	+81 3 5769 6803
		Russia/CIS	+7 495 995 9559	South Korea	+82 2 3438 4600
		Egypt	0800 000 0015	Singapore	+65 6 777 8211
		Oman	800 70101	Thailand	001 800 441 6426
		Qatar	431 0044	Malaysia	800 814 008
		Kuwait	663 299 01		
		South Africa	800 991 390		
		Saudi Arabia	800 844 9564		
		UAE	800 0444 0684		

3 Pre-installation

Before installing the transmitter, there are several pre-installation steps that should be completed to make the installation process easier:

- Identify options and configurations that apply to your application
- Set the hardware switches if necessary
- Consider mechanical, electrical, and environmental requirements

Note

Refer to the product reference manual for more detailed requirements.

Identify options and configurations

The typical transmitter installation includes a device power connection, a 4-20mA output connection, and sensor coil and electrode connections. Other applications may require one or more of the following configurations or options:

- Pulse output
- Discrete input/discrete output
- HART multidrop configuration

The transmitter may have up to four user-selectable hardware switches. These switches set the alarm mode, internal/external analog power, internal/external pulse power, and transmitter security. The standard configuration for these switches when shipped from the factory is as follows:

Table 3-1: Hardware switch default settings

Setting	Factory configuration
Alarm mode	High
Internal/external analog power	Internal
Internal/external pulse power	External
Transmitter security	Off

The analog power switch and pulse power switches are not available when ordered with intrinsically safe output, ordering code B.

In most cases, it is not necessary to change the setting of the hardware switches. If the switch settings need to be changed, refer to the product reference manual.

Be sure to identify any additional options and configurations that apply to the installation. Keep a list of these options for consideration during the installation and configuration procedures.

Mechanical considerations

The mounting site for the transmitter should provide enough room for secure mounting, easy access to conduit entries, full opening of the transmitter covers, and easy readability of the Local Operator Interface (LOI) screen (if equipped).

Figure 3-1: Rosemount 8782 Dimensional Drawing

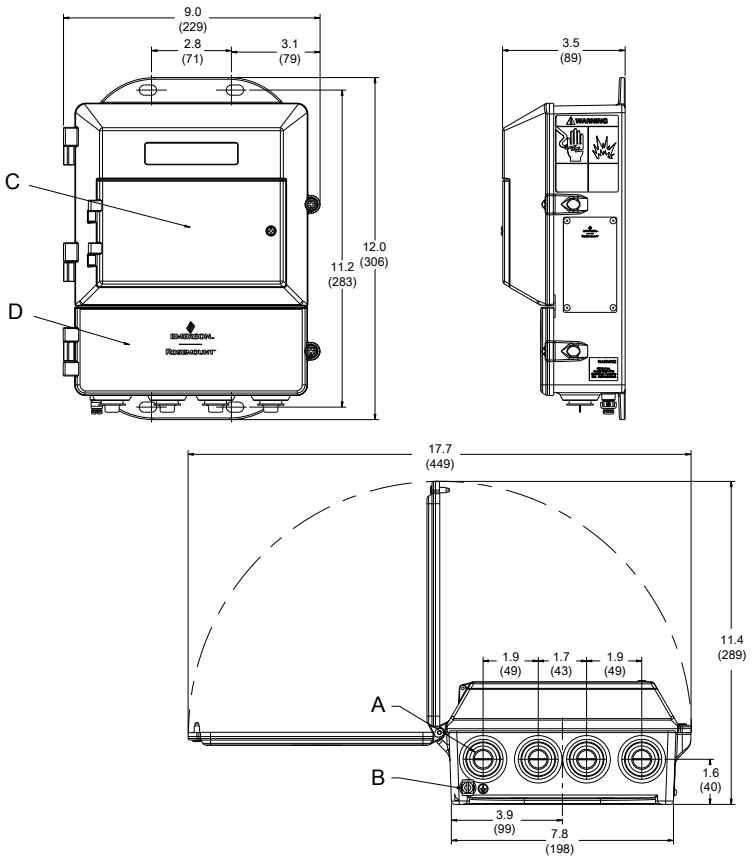

- A. Conduit entry, ½–14 NPT (4 places)
- B. Ground lug
- C. LOI keypad cover
- D. Lower cover opens for electrical connections

Note

Dimensions are in inches (Millimeters)

Electrical considerations

Before making any electrical connections to the transmitter, consider national, local, and plant electrical installation requirements. Be sure to have

the proper power supply, conduit, and other accessories necessary to comply with these standards.

The transmitter requires external power. Ensure access to a suitable power source.

Table 3-2: Electrical Data

Electrical data	
Power input	AC power: 90–250 VAC (⎓), 1.5A, 120 VA
	Standard DC power: 12–42 VDC (==), 8.6 A, 120 W
Pulsed circuit	Internally powered (Active): Outputs up to 12 VDC, 12.1 mA, 73 mW Externally powered (Passive): Input up to 28 VDC, 100 mA, 1 W
4-20mA output circuit	Internally Powered (Active): Outputs up to 25 mA, 24 VDC, 600 mW Externally Powered (Passive): Input up to 25 mA, 30 VDC, 750 mW
Um	250 V
Coil excitation output	2.0 A, 85 V max, 80 W max

Environmental considerations

Remote mounted transmitters may be installed in the control room to protect the electronics from the harsh environment and to provide easy access for configuration or service.

Table 3-3: Transmitter housing environmental ratings

Type	Rating
Ingress protection	IP66, IP69
NEMA	4X
Pollution Degree	2
Maximum altitude rating	<ul style="list-style-type: none"> 13,123 ft (4000 m) at rated input power voltage (90–250 VAC) 16,404 ft (5000 m) at maximum input power voltage of 150 VAC

Note

For complete environmental and other specifications, refer to the product reference manual.

4 Mounting

Wall mount transmitters are shipped with mounting hardware for use on a 2 inch (50 mm) pipe or flat surface.

Figure 4-1: Mounting bracket

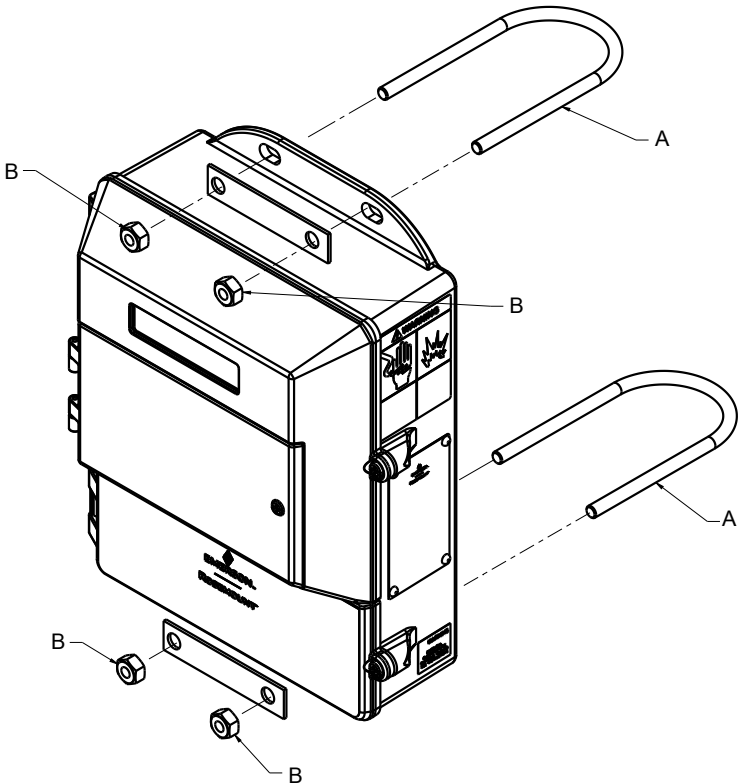

- A. U-bolt
B. Fasteners

4.1 Pipe mounting

1. Assemble the hardware and transmitter housing on the pole as shown in [Figure 4-1](#).
2. Tighten the nuts to ensure a snug fit.

4.2 Surface mounting

Attach the transmitter to the mounting location using customer supplied mounting screws. The installation of the transmitter shall be rated for four (4) times the weight of the transmitter or 44lbs (20kgs).

5 Wiring

5.1 Conduit entries and connections

Transmitter conduit entries ports are ½"-14NPT as standard, M20 conduit connections will use an adapter. Conduit connections should be made in accordance with national, local, and plant electrical codes. Unused conduit entries should be sealed with the appropriate certified plugs. The plastic shipping plugs do not provide ingress protection.

5.2 Conduit requirements

- For installations with an intrinsically safe electrode circuit, a separate conduit for the coil cable and the electrode cable may be required.
- For installations with non-intrinsically safe electrode circuit, a single dedicated conduit run for the coil drive and electrode cable between the sensor and the remote transmitter may be acceptable. Removal of the barriers for intrinsic safety isolation is permitted for non-intrinsically safe electrode installations.
- Bundled cables from other equipment in a single conduit are likely to create interference and noise in the system. See [Figure 5-1](#).
- Electrode cables should not be run together in the same cable tray with power cables.
- Output cables should not be run together with power cables.
- Select conduit size appropriate to feed cables through to the flowmeter.

Figure 5-1: Best practice conduit preparation

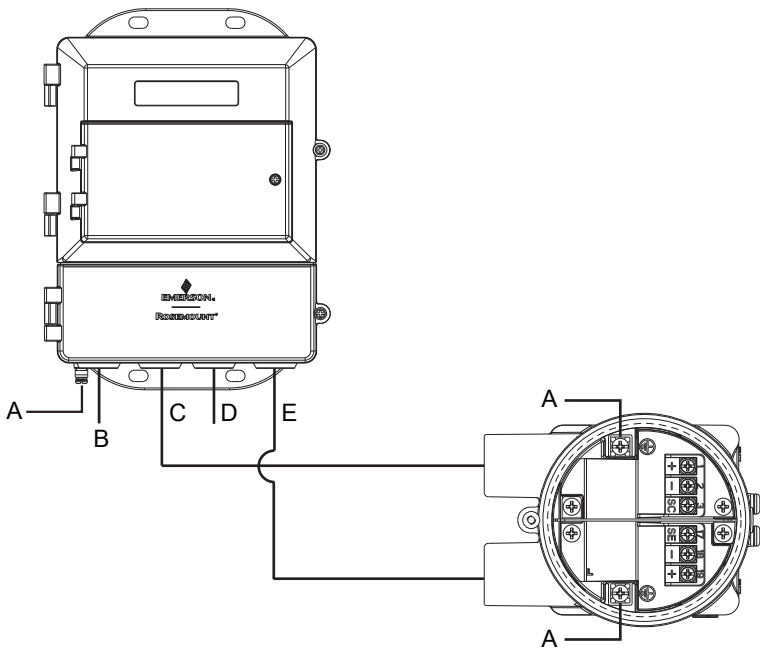

- A. Safety ground
- B. Power
- C. Coil
- D. Output
- E. Electrode

5.3 Sensor to transmitter wiring

Remote cable kits can be ordered directly using the kit numbers shown in [Table 5-1](#) and [Table 5-2](#). Equivalent Alpha cable part numbers are also provided as an alternative. To order cable, specify length as quantity desired. Equal length of component cables is required.

Examples:

- 25 feet = Qty (25) 08732-0065-0001
- 25 meters = Qty (25) 08732-0065-0002

Table 5-1: Component cable kits - standard temperature (-20°C to 75°C)

Cable kit #	Description	Individual cable	Alpha p/n
08732-0065-0001 (feet)	Kit, component cables, Std temp (includes Coil and Electrode)	Coil Electrode	2442C 2413C
08732-0065-0002 (meters)	Kit, component cables, Std temp (includes Coil and Electrode)	Coil Electrode	2442C 2413C
08732-0065-0003 (feet)	Kit, component cables, Std temp (includes Coil and I.S. Electrode)	Coil Intrinsically Safe Blue Electrode	2442C Not available
08732-0065-0004 (meters)	Kit, component cables, Std temp (includes Coil and I.S. Electrode)	Coil Intrinsically Safe Blue Electrode	2442C Not available

Table 5-2: Component cable kits - extended temperature (-50°C to 125°C)

Cable kit #	Description	Individual cable	Alpha p/n
08732-0065-1001 (feet)	Kit, Component Cables, Ext Temp. (includes Coil and Electrode)	Coil Electrode	Not available Not available
08732-0065-1002 (meters)	Kit, Component Cables, Ext Temp. (includes Coil and Electrode)	Coil Electrode	Not available Not available
08732-0065-1003 (feet)	Kit, Component Cables, Ext Temp. (includes Coil and I.S. Electrode)	Coil Intrinsically Safe Blue Electrode	Not available Not available
08732-0065-1004 (meters)	Kit, Component Cables, Ext Temp. (includes Coil and I.S. Electrode)	Coil Intrinsically Safe Blue Electrode	Not available Not available

Cable requirements

Shielded twisted pairs or triads must be used. See [Figure 5-2](#). Cable lengths should be limited to less than 300 feet (100 m).

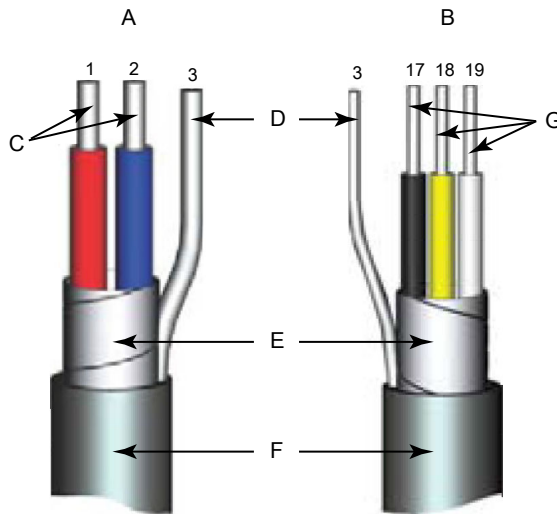
Figure 5-2: Individual component cables

- A. Coil drive
 - B. Electrode
 - C. Twisted, stranded, insulated 14 AWG conductors
 - D. Drain
 - E. Overlapping foil shield
 - F. Outer jacket
 - G. Twisted, stranded, insulated 20 AWG conductors
- 1 = Red
 - 2 = Blue
 - 3 = Drain
 - 17 = Black
 - 18 = Yellow
 - 19 = White

Cable preparation

Prepare the ends of the coil drive and electrode cables as shown in [Figure 5-3](#). Remove only enough insulation so that the exposed conductor fits completely under the terminal connection. Best practice is to limit the unshielded length (D) of each conductor to less than one inch. Excessive removal of insulation may result in an unwanted electrical short to the transmitter housing or other terminal connections. Excessive unshielded

length, or failure to connect cable shields properly, may also expose the unit to electrical noise, resulting in an unstable meter reading.

Figure 5-3: Cable ends

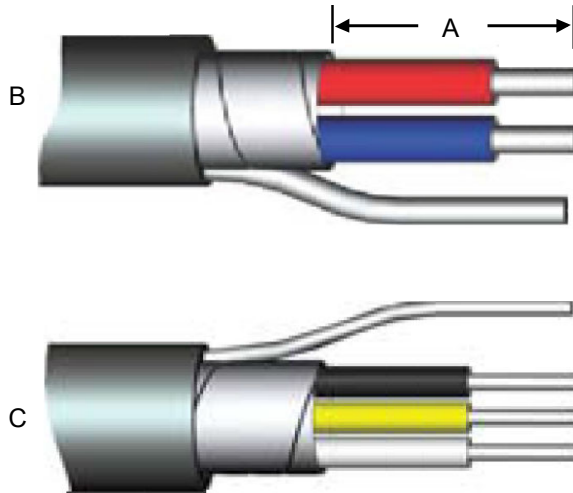

- A. Unshielded length
- B. Coil
- C. Electrode

⚠ WARNING

Shock hazard! Potential shock hazard across remote junction box terminals 1 and 2 (85V).

⚠ WARNING

Explosion hazard! Electrodes exposed to process. Use only compatible transmitter and approved installation practices. For process temperatures greater than 284°F (140°C), use a wire rated for 257°F (125°C).

Remote junction box terminal blocks

Figure 5-4: Remote junction box views

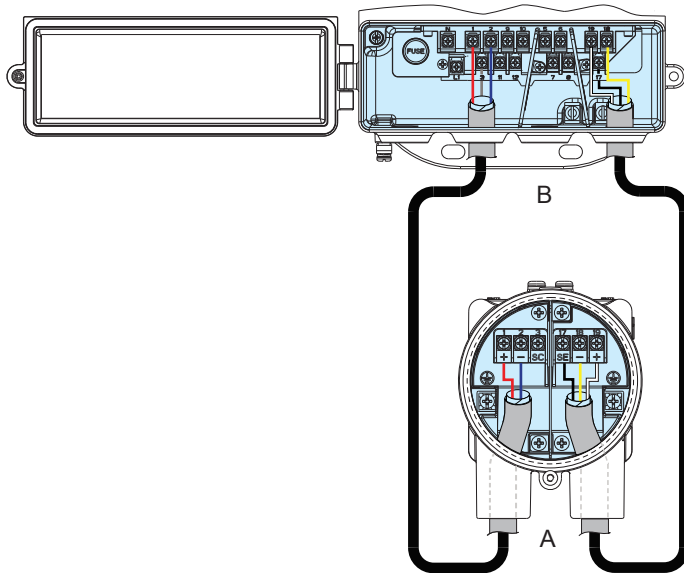

- A. Sensor
- B. Transmitter

Note

Junction box appearance and configuration may vary, but terminal numbering is consistent for all junction box types.

Table 5-3: Sensor/transmitter wiring

Wire color	Sensor terminal	Transmitter terminal
Red	1	1
Blue	2	2
Coil drain	3 or float	3
Black	17	17
Yellow	18	18
White	19	19
Electrode drain	⊖ or float	⊖

5.4 Wiring sensor to transmitter

Figure 5-5: Wiring using component cable

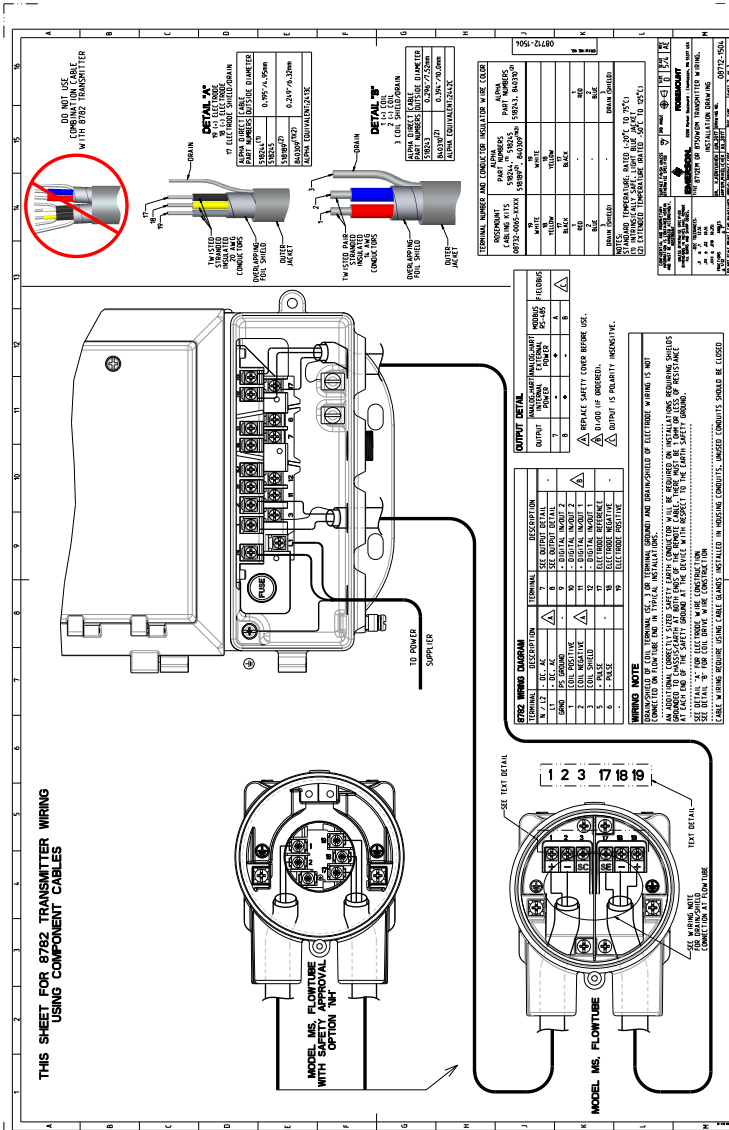

5.5 Power and I/O terminal blocks

Open the bottom cover of the transmitter to access the terminal block.

Note

To connect pulse output and/or discrete input/output, and for installations with intrinsically safe outputs, refer to the product reference manual.

Figure 5-6: Terminal blocks

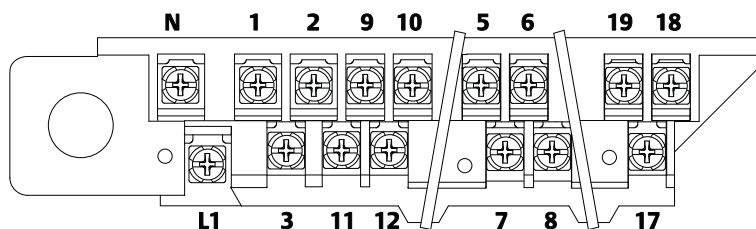

Table 5-4: Power and I/O terminals

Terminal number	AC version	DC version
1	Coil Positive	Coil Positive
2	Coil Negative	Coil Negative
3	Coil Shield	Coil Shield
5	+ Pulse	+ Pulse
6	- Pulse	- Pulse
7 ⁽¹⁾	Analog HART	Analog HART
8 ⁽¹⁾	Analog HART	Analog HART
9 ⁽²⁾	+ Discrete In/Out 2	+ Discrete In/Out 2
10 ⁽²⁾	- Discrete In/Out 2	- Discrete In/Out 2
11 ⁽²⁾	+ Discrete In/Out 1	+ Discrete In/Out 1
12 ⁽²⁾	- Discrete In/Out 1	- Discrete In/Out 1
17	Electrode Reference	Electrode Reference
18	Electrode Negative	Electrode Negative
19	Electrode Positive	Electrode Positive
N	AC (Neutral)	DC (-)

Table 5-4: Power and I/O terminals (continued)

Terminal number	AC version	DC version
L1	ACL1	DC (+)

- (1) *Note Polarity: Internally Powered, Terminal 7 (-) Analog HART, Terminal 8 (+) Analog HART. Externally Powered, Terminal 7 (+) Analog HART, Terminal 8 (-) Analog HART*
- (2) *Only available with ordering code AX.*

5.6 Powering the transmitter

Before connecting power to the transmitter, be sure to have the necessary electrical supplies and required power source:

Wire the transmitter according to national, local, and plant electrical requirements.

If installing in a hazardous location, verify that the meter has the appropriate hazardous area approval. The hazardous area ratings are located on the main nameplate tag attached to the side of the transmitter.

Supply wire requirements

Use 10–18 AWG wire rated for the proper temperature of the application. For wire 10–14 AWG use lugs or other appropriate connectors. For connections in ambient temperatures above 122 °F (50 °C), use a wire rated for 194 °F (90 °C). For DC powered transmitters with extended cable lengths, verify that there is a minimum of 12VDC at the terminals of the transmitter with the device under load.

Electrical disconnect requirements

Connect the device through an external disconnect or circuit breaker per national and local electrical code.

Overcurrent protection

The transmitter requires overcurrent protection of the supply lines. Fuse rating and compatible fuses are shown in [Line power fuses](#).

Installation category

The installation category for the transmitter is OVERVOLTAGE CAT II.

AC power system installation requirements

Neutral-earth power requirements

- The power system must have a neutral that is locally bonded to earth, or provide both line to earth and neutral to earth voltage limitation of no more than 250 VAC.

Power line impedance

- Sources of inductance on the AC power system, such as isolation transformers, must be limited to less than 1 mH at 120 VAC, and 2 mH at 240 VAC.

Power terminals

For AC powered transmitter (90–250VAC, 50/60 Hz):

- Connect AC Neutral to Terminal N and AC Line to Terminal L1.

For DC powered transmitter:

- Connect negative to Terminal N and positive to Terminal L1.
- DC powered units may draw up to 8.6 A.

Power supply

- 90 VAC to 250 VAC @ 50/60Hz.
 - Overvoltage Category II
 - Single Phase Earthed Neutral System
- 12 VDC to 42 VDC.

Note

For applications with sensors greater than 14 inch (350 mm) and process temperature greater than 212 °F (100 °C), consult an Emerson Flow representative (see back page) when applying less than 18 VDC to power terminals.

Line power fuses

Power supply type	Rating	Manufacturer part number
90–250 VAC	2.5 A, 250 VAC	Bel Fuse 3AG 2.5-R, Littelfuse 312025, or equivalent
12–42 VDC	12 A, 250 VAC	Bel Fuse 3AB 12-R, Littelfuse 314012, or equivalent

Power consumption

- 90 VAC to 250 VAC: 120 VA maximum
- 12 VDC to 42 VDC: 120 W maximum

Inrush/Start-up current

The power system must be capable of supporting inrush/start-up currents of:

- AC supply: Maximum 7 A (<5 ms)
- DC supply: Maximum 13 A (<5 ms)

AC power supply requirements

Units powered by 90 VAC to 250 VAC have the following power requirements. Peak inrush is 7 A at 250 VAC supply, lasting approximately 1 ms.

Figure 5-7: AC current requirements

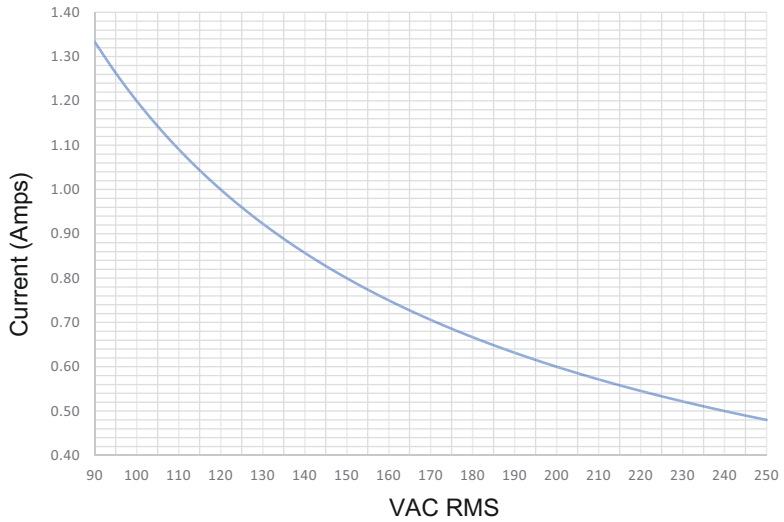

DC power supply requirements

Units powered by 12 VDC power supply may draw up to 8.6 A of current steady state. Peak inrush is 13 A at 12 VDC supply, lasting approximately 1 ms.

Figure 5-8: DC current requirements

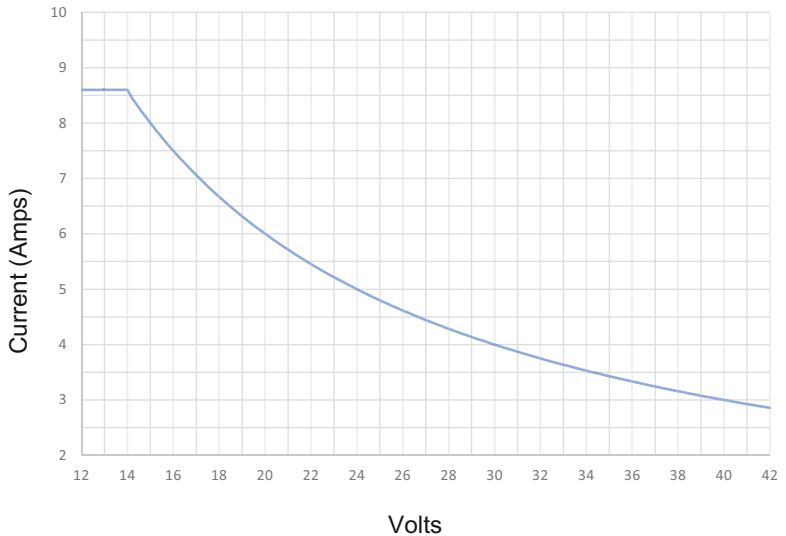

- A. Supply current (amps)
B. Power supply (VDC)

Covers

Use the transmitter lower door screw to secure the terminal compartment after the instrument has been wired. Follow these steps to ensure the housing is properly sealed to meet ingress protection requirements:

1. Ensure all wiring is complete and close the lower door.
2. Tighten the lower door screw until the lower door is tight against the housing. Metal to metal contact of the screw bosses is required to ensure a proper seal.

Note

Application of excessive torque may strip the threads or break the screw.

3. Verify the lower door is secure.

5.7 Analog output

The analog output signal is a 4-20 mA current loop. Depending on the IS output option, the loop can be powered internally or externally via a hardware switch located on the front of the electronics stack. The switch is set to internal power when shipped from the factory. Intrinsically safe analog output requires a shielded twisted pair cable. For HART communication, a minimum resistance of 250 ohms is required. It is recommended to use individually shielded twisted pair cable. The minimum conductor size is 24 AWG (0.51 mm) diameter for cable runs less than 5,000 feet (1,500 m) and 20 AWG (0.81 mm) diameter for longer distances.

Note

For more information about the analog output characteristics, refer to the product reference manual.

Figure 5-9: Analog output wiring

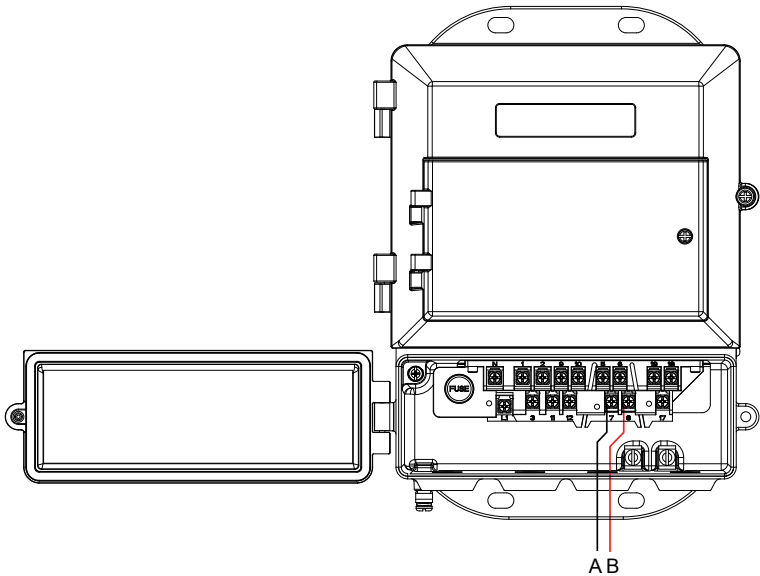

- A. Terminal #7
- B. Terminal #8

Note

Terminal polarity for the analog output is reversed between internally and externally powered.

Table 5-5: Terminal assignment by power source type

Power source	Terminal #7	Terminal #8
Internal	4–20 mA negative (-)	4–20 mA positive (+)
External	4–20 mA positive (+)	4–20 mA negative (-)

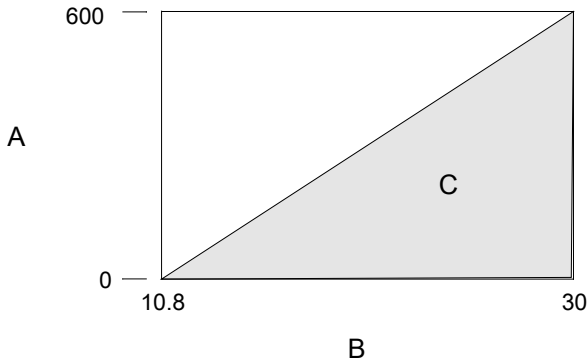
Figure 5-10: Analog loop load limitations

- A. Load (ohms)
- B. Power supply (volts)
- C. Operating region

- $R_{\max} = 31.25 (V_{ps} - 10.8)$
- V_{ps} = power supply voltage (volts)
- R_{\max} = maximum loop resistance (ohms)

6 Basic Configuration

Once the flow meter is installed and power has been supplied, the transmitter must be configured using the LOI, if equipped, or a configuration tool, such as ProLink III Software, AMS Device Manager, or AMS Trex Device Communicator. Configuration settings are saved in nonvolatile memory within the transmitter. Descriptions of more advanced functions are included in the product reference manual.

6.1 Basic Setup

Tag

Tag is the quickest and shortest way of identifying and distinguishing between transmitters. Transmitters can be tagged according to the requirements of your application. The tag can be up to 32 characters long.

Calibration number

The sensor calibration number is a 16-digit number generated at the factory during flow calibration, is unique to each sensor, and is located on the sensor tag.

Flow units (PV)

The flow units variable specifies the format in which the flow rate will be displayed. Units should be selected to meet your particular metering needs. .

Line size

The line size (sensor size) must be set to match the actual sensor connected to the transmitter. The size must be specified in inches.

Upper range value (URV)

The URV sets the 20 mA point for the analog output. This value is typically set to full-scale flow. The units that appear will be the same as those selected under the flow units parameter. The URV may be set between -39.3 ft/s to 39.3 ft/s (-12 m/s to 12 m/s). There must be at least 1 ft/s (0.3 m/s) span between the URV and LRV.

Lower range value (LRV)

The LRV sets the 4 mA point for the analog output. This value is typically set to zero flow. The units that appear will be the same as those selected under the flow units parameter. The LRV may be set between -39.3 ft/s to 39.3 ft/s (-12 m/s to 12 m/s). There must be at least 1 ft/s (0.3 m/s) span between the URV and LRV.

Auto zero

The Auto zero is recommended for optimum performance when a flow meter is initially installed, and it typically does not need to be performed again. However, if process conditions drastically change, a new Auto zero is recommended. The sensor must be filled completely with process fluid at zero flow. For more information, refer to the product reference manual.

6.2 Local operator interface (LOI)

To access the transmitter menu, press the XMTR MENU key. Use the UP, DOWN, LEFT(E), and RIGHT arrows to navigate the menu structure.

The display can be locked to prevent unintentional configuration changes. The display lock can be activated through a HART communication device, or by holding the UP arrow for three seconds and then following the on-screen instructions.

6.3 Other configuration tools

Table 6-1 shows the approximate category or location of basic setup parameters for typical configuration tools.

Table 6-1: Approximate setup category/locations for typical configuration tools

Function	Category/Location
Flow Units	Basic Setup
PV Upper Range Value (URV)	Basic Setup → AO
PV Lower Range Value (LRV)	Basic Setup → AO
Auto zero	Diagnostics
Calibration Number	Basic Setup → Setup
Line Size	Basic Setup → Setup
Tag	Device Info → Identification
Long Tag	Device Info → Identification

7 Product Certifications

For detailed approval certification information and installation drawings, please see the appropriate document listed below:

- Document number 00825-MA00-0009: *Rosemount 8782 and MS Approval Document - Class Division*
- Document number 00825-MA00-0010: *Rosemount 8782 and MS Approval Document - IECEx and ATEX*
- Document number 00825-MA00-0011: *Rosemount 8782 and MS Approval Document - North America Zone*
- Document number 00825-MA00-0012: *Rosemount 8785 Approval Document*
- Document number 00825-MA00-0013: *Rosemount 8782 and MS Approval Document - EAC EX*



Quick Start Guide
00825-0100-8782, Rev. AA
November 2019

Emerson Automation Solutions USA

7070 Winchester Circle
Boulder, Colorado USA 80301
T +1 303-527-5200
T +1 800-522-6277
F +1 303-530-8459
www.emerson.com

Emerson Automation Solutions Asia

1 Pandan Crescent
Singapore 128461
Republic of Singapore
T +65 6363-7766
F +65 6770-8003

Emerson Automation Solutions Europe

Neonstraat 1
6718 WX Ede
The Netherlands
T +31 (0) 70 413 6666
F +31 (0) 318 495 556
www.micromotion.nl

Emerson Automation Solutions United Kingdom

Emerson Process Management Limited
Horsfield Way
Bredbury Industrial Estate
Stockport SK6 2SU U.K.
T +44 0870 240 1978
F +44 0800 966 181

©2019 Rosemount, Inc. All rights reserved.

The Emerson logo is a trademark and service mark of Emerson Electric Co. Rosemount, 8600, 8700, 8800 marks are marks of one of the Emerson Automation Solutions family of companies. All other marks are property of their respective owners.