

Rosemount™ 2120 Level Switch

Vibrating Fork



Contents

About this guide.....	3
Installation.....	5
Prepare the electrical connections.....	11
Connect wiring and power up.....	26
Configuration.....	30
Operation.....	32

1 About this guide

This Quick Start Guide provides basic guidelines for the Rosemount 2120. Refer to the Rosemount 2120 [Reference Manual](#) for more instructions. The manual and this guide are also available electronically at Emerson.com/Rosemount.

1.1 Safety messages

⚠ WARNING

Failure to follow safe installation and servicing guidelines could result in death or serious injury.

Ensure the level switch is installed by qualified personnel and in accordance with applicable code of practice.

Use the level switch only as specified in this manual. Failure to do so may impair the protection provided by the level switch.

The weight of a level switch with a heavy flange and extended fork length may exceed 37 lb. (18 kg). A risk assessment is required before carrying, lifting, and installing the level switch.

Repair, e.g. substitution of components, etc. may jeopardize safety and is under no circumstances allowed.

⚠ WARNING

Explosions could result in death or serious injury.

Verify the operating atmosphere of the level switch is consistent with the appropriate hazardous locations certifications.

Before connecting a handheld communicator in an explosive atmosphere, ensure the instruments are installed in accordance with intrinsically safe or non-incendive field wiring practices.

In explosion-proof/flameproof and non-incendive installations, do not remove the housing cover when power is applied to the level switch.

The housing cover must be fully engaged to meet flameproof/explosion-proof requirements.

⚠ WARNING**Electrical shock could cause death or serious injury.**

Avoid contact with the leads and terminals. High voltage that may be present on leads can cause electrical shock.

Ensure the power to the level switch is off, and the lines to any other external power source are disconnected or not powered while wiring the level switch.

Ensure the wiring is suitable for the electrical current and the insulation is suitable for the voltage, temperature, and environment.

⚠ WARNING**Process leaks could result in death or serious injury.**

Ensure the level switch is handled carefully. If the process seal is damaged, gas might escape from the vessel (tank) or pipe.

⚠ WARNING**Physical access**

Unauthorized personnel may potentially cause significant damage to and/or misconfiguration of end users' equipment. This could be intentional or unintentional and needs to be protected against.

Physical security is an important part of any security program and fundamental to protecting your system. Restrict physical access by unauthorized personnel to protect end users' assets. This is true for all systems used within the facility.

⚠ CAUTION**Hot surfaces**

The flange and process seal may be hot at high process temperatures. Allow to cool before servicing.



2 Installation

2.1 Fork alignment in a pipe installation

The fork is correctly aligned by positioning the groove or notch as indicated (Figure 2-1).

Figure 2-1: Correct Fork Alignment for Pipe Installation

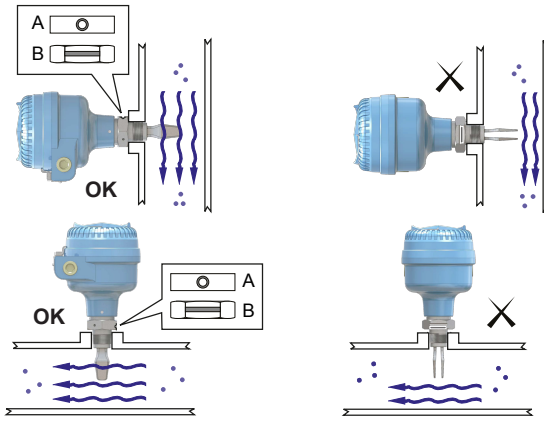

- A. Tri Clamp process connections have a circular notch
- B. Threaded process connections have a groove

2.2 Fork alignment in a vessel (tank) installation

The fork is correctly aligned by positioning the groove or notch as indicated (Figure 2-2).

Figure 2-2: Correct Fork Alignment for Vessel (Tank) Installation

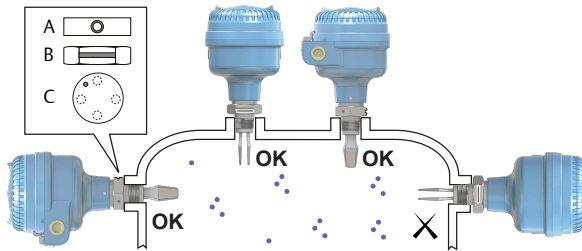

- A. Tri Clamp process connections have a circular notch
- B. Threaded process connections have a groove
- C. Flanged process connections have a circular notch

2.3 Mounting the threaded version

2.3.1 Threaded vessel (tank) or pipework connection

Procedure

1. Seal and protect the threads. Use anti-seize paste or PTFE tape according to site procedures.

A gasket may be used as a sealant for BSPP (G) threaded connections.

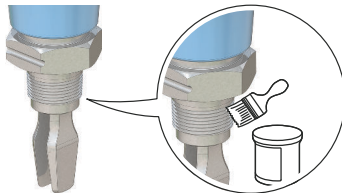

2. Screw the level switch into the process connection.

Note

Tighten using the hexagon nut only.

Figure 2-3: Vertical Installation

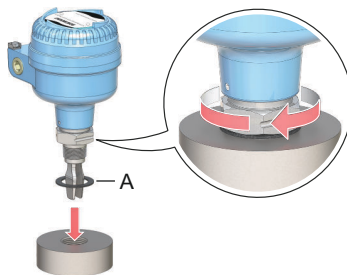

A. Gasket for BSPP (G) threaded connection

Figure 2-4: Horizontal Installation

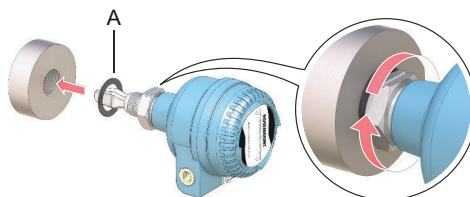

A. Gasket for BSPP (G) threaded connection

2.3.2 Threaded flange connection

Procedure

1. Place the customer-supplied flange and gasket on the vessel (tank) nozzle.

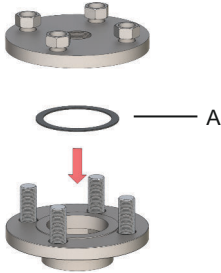

A. Gasket (customer supplied)

2. Tighten the bolts and nuts with sufficient torque for the flange and gasket.

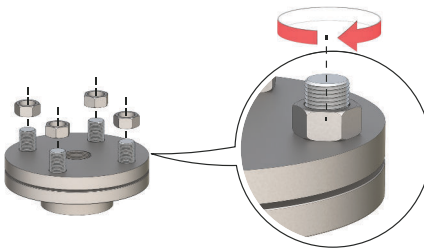

3. Seal and protect the threads. Use anti-seize paste or PTFE tape according to site procedures.

A gasket may be used as a sealant for BSPP (G) threaded connections.

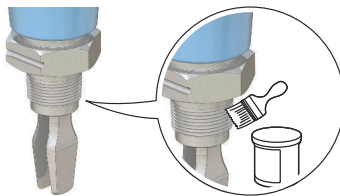

4. Screw the level switch into the flange thread.

Note

Tighten using the hexagon nut only.

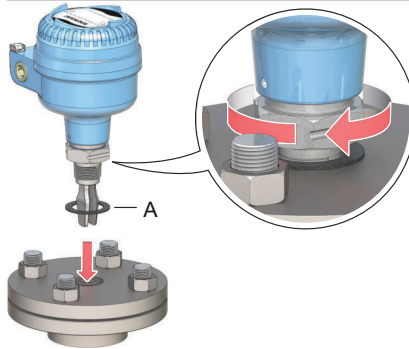

A. Gasket for BSPP (G) threaded connection

2.4 Mounting the flanged version

Procedure

1. Lower the level switch into the nozzle.

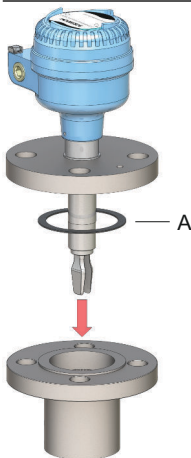

A. Gasket (customer supplied)

2. Tighten the bolts and nuts with sufficient torque for the flange and gasket.

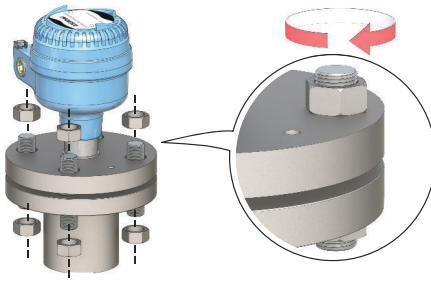

2.5 Mounting the Tri Clamp version

Procedure

1. Lower the level switch into the flange face.

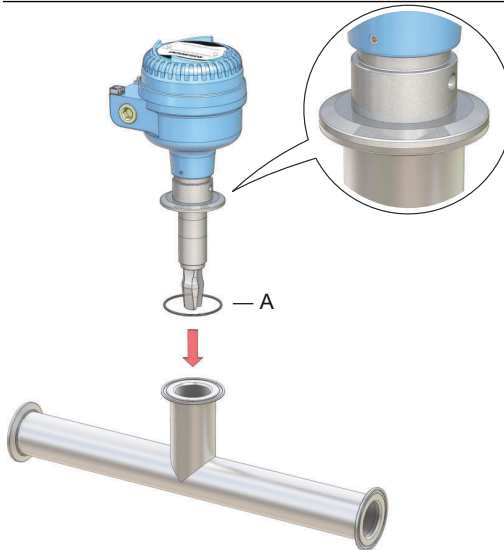

A. Seal (supplied with Tri Clamp)

2. Fit the Tri Clamp.

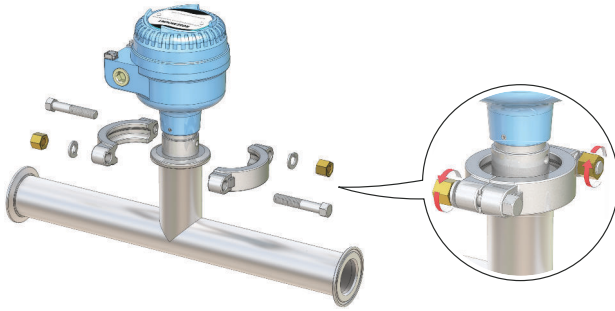

3 Prepare the electrical connections

3.1 Cable selection

Use 26–14 AWG (0.13 to 2.5 mm²) AWG wiring. Twisted-pairs and shielded wiring is recommended for environments with high EMI (electromagnetic interference). Two wires can be safely connected to each terminal screw.

3.2 Cable glands/conduits

For intrinsically safe, explosion-proof/flameproof, and dust-proof installations, only use certified cable glands or conduit entry devices. Ordinary location installations can use suitably rated cable glands or conduit entry devices to maintain the Ingress Protection (IP) rating.

Unused conduit entries must always be sealed with a suitably rated blanking/stopping plug.

Note

Do not run signal wiring in conduit or open trays with power wiring or near heavy electrical equipment.

3.3 Power supply

The power supply requirements are dependent on the electronics selected.

- Direct load switching: 20 - 60 Vdc or 20 - 264 Vac (50/60 Hz)
- PNP/PLC electronics: 20 - 60 Vdc
- Relay DPCO (Double Pole Changeover) electronics (standard): 20 - 60 Vdc or 20 - 264 Vac (50/60 Hz)
- Relay DPCO electronics (12 Vdc nominal): 9 - 30 Vdc
- NAMUR electronics: 8 Vdc
- 8/16 mA electronics: 24 Vdc

3.4 Hazardous areas

When the device is installed in hazardous areas (classified locations), local regulations and the conditions-of-use specified in applicable certificates must be observed. Review the Rosemount 2120 [Product Certifications](#) document for information.

3.5 Wiring diagrams

⚠ CAUTION

- Before use, check the cable glands and blanking plugs are suitably rated.
 - Isolate supply before connecting the switch or removing the electronics.
 - The Protective Earth (PE) \oplus terminal must be connected to an external earthing system.
-

3.5.1 Direct load switching cassette

Figure 3-1: Direct Load Switching (2-wire) Cassette (Red Label) – Code T

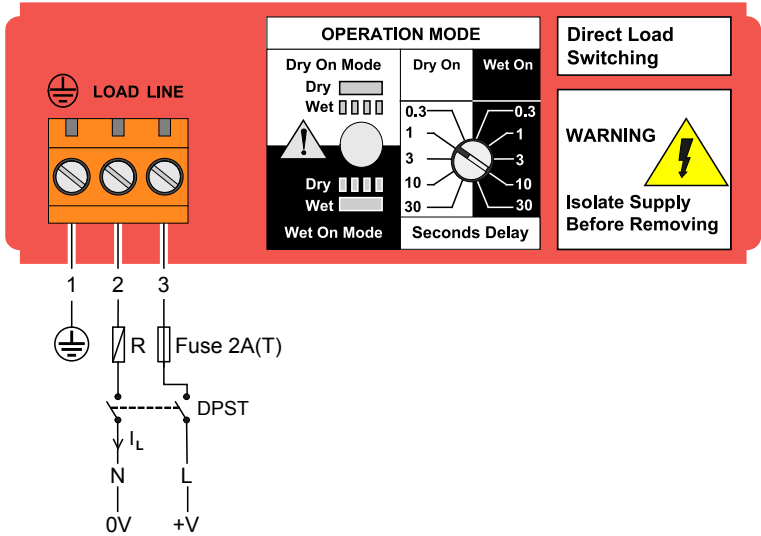

R = External load (must be fitted)

N = Neutral

L = Live

Note

A DPST (Double Pole, Single Throw) on/off switch must be fitted for safe disconnection of the power supply. Fit the DPST switch as near as possible to the level switch. Keep the DPST switch free of obstructions. Label the DPST switch to indicate it is the supply disconnection device for the level switch.

Table 3-1: Electrical Parameters

Parameter	Value
U	20 - 60 Vdc or 20 - 264 Vac (50/60 Hz)
I _{OFF}	< 4 mA
I _L	20 - 500 mA
I _{PK}	5 A, 40 ms (inrush)

Table 3-2: Direct Load Functions

Mode: dry on, high level alarm		Mode: wet on, low level alarm	
LED on continuously	LED flashes every second	LED on continuously	LED flashes every second
= Load on = Load off			

3.5.2 PNP/PLC cassette

Figure 3-2: PNP/PLC (3-wire) Cassette (Yellow Label) – Code G

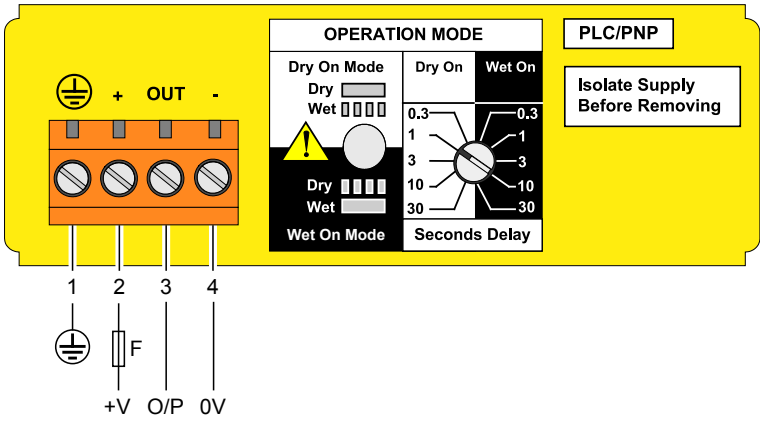

F = Fuse 2A(T)

Table 3-3: Electrical Parameters

Parameter	Value
U	20 - 60 Vdc
I	< 4 mA + I _L
I _{L(OFF)}	< 100 μA
I _{L(MAX)}	0 - 500 mA
I _{PK}	5 A, 40 ms (inrush)
U _{OUT(ON)}	U - 2.5 Vdc (20 °C) U - 2.75 Vdc (-40 to 80 °C)

Table 3-4: PNP/PLC Cassette Functions

Mode: dry on, high level alarm		Mode: wet on, low level alarm	
PLC (positive input)			
PNP dc			
LED			
LED on continuously	LED flashes every second	LED on continuously	LED flashes every second

3.5.3 Relay DPCO cassette (standard version)

Figure 3-3: Relay DPCO Cassette, Standard Version (Green Label) – Code V

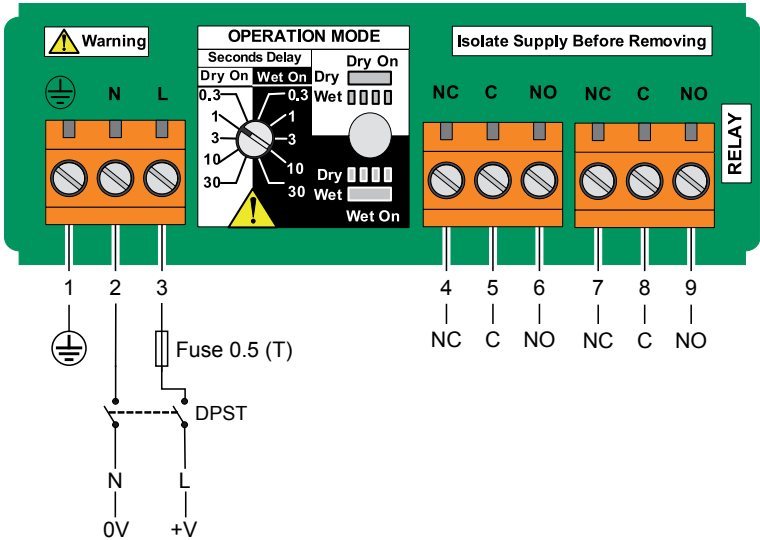

Note

A DPST (Double Pole, Single Throw) on/off switch must be fitted for safe disconnection of the power supply. Fit the DPST switch as near as possible to the level switch. Keep the DPST switch free of obstructions. Label the DPST switch to indicate it is the supply disconnection device for the level switch.

Table 3-5: Electrical Parameters

Parameter	Value
U	20 - 60 Vdc or 20 - 264 Vac (50/60Hz)
I	< 6 mA

Table 3-6: NC, C, and NO Terminals

Parameter		Resistive load	Inductive load
cos ϕ		1	0.4
L/R		0 ms	7 ms
I _{MAX}		5 A	3.5 A
U _{MAX}	ac	250 V	250 V
	dc	30 V	30 V
P _{MAX}	ac	1250 VA	875 VA
	dc	240 W	170 W

Table 3-7: Relay Cassette Functions

Mode: dry on, high level alarm		Mode: wet on, low level alarm	
<p>LED on continuously</p>	<p>LED flashes every second</p>	<p>LED on continuously</p>	<p>LED flashes every second</p>

3.5.4 Relay DPCO cassette (12 Vdc nominal version)

Figure 3-4: Relay DPCO Cassette, 12 Vdc Nominal Version (Green Label) – Code E

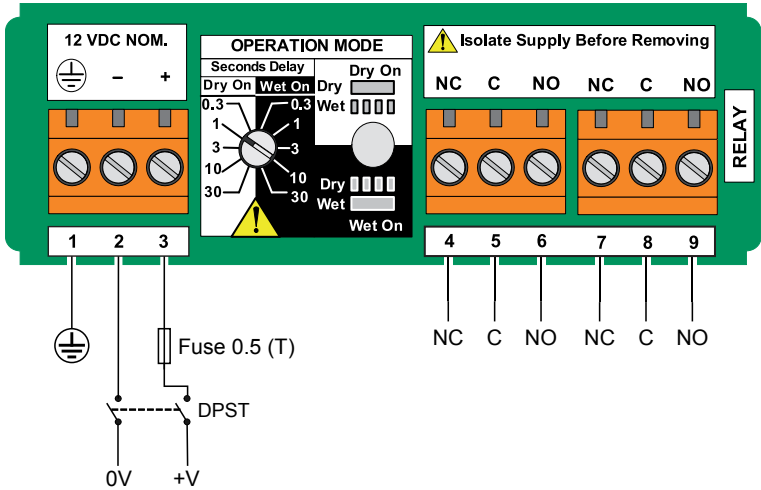

Note

A DPST (Double Pole, Single Throw) on/off switch must be fitted for safe disconnection of the power supply. Fit the DPST switch as near as possible to the Rosemount 2120. Keep the DPST switch free of obstructions. Label the DPST switch to indicate it is the supply disconnection device for the Rosemount 2120.

Table 3-8: Electrical Parameters

Parameter	Value
U	9 - 30 Vdc
I	< 4 mA

Table 3-9: NC, C, and NO Terminals

Parameter	Resistive load	Inductive load
cos ϕ	1	0.4
L/R	0 ms	7 ms
I _{MAX}	2 A	1 A
U _{MAX}	30 V	30 V
P _{MAX}	60 W	30 W

Table 3-10: Relay Cassette Functions

Mode: dry on, high level alarm		Mode: wet on, low level alarm	
 NC C NO NC C NO	 NC C NO NC C NO	 NC C NO NC C NO	 NC C NO NC C NO
 LED on continuously	 LED flashes every second	 LED on continuously	 LED flashes every second

3.5.5 NAMUR cassette

Figure 3-5: NAMUR Cassette (Light Blue Label) – Code K

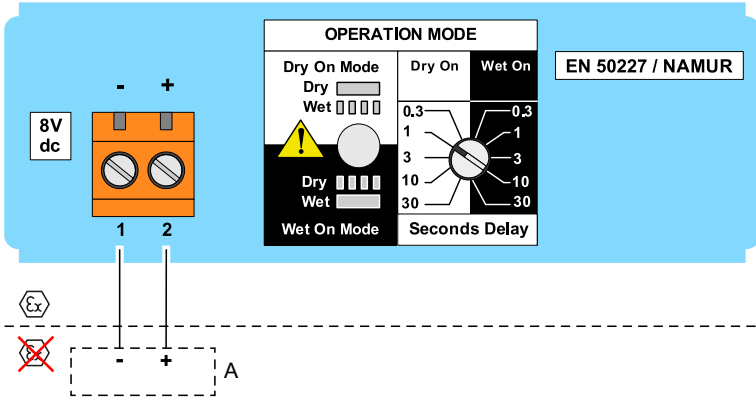

A. A certified intrinsically safe isolating amplifier to IEC 60947-5-6

Note

- This cassette is suitable for Intrinsically Safe (IS) applications and requires a certified isolating barrier. See the Rosemount 2120 [Product Certifications](#) document for Intrinsically Safe approvals.
- This electronics cassette is also suitable for non-hazardous (safe) area applications.
- It can only be interchanged with the 8/16 mA cassette.
- Do not exceed 8 Vdc.

Table 3-11: Electrical Parameters

Parameter	Value
I _{ON}	2.2 - 2.5 mA
I _{OFF}	0.8 - 1.0 mA
I _{FAULT}	< 1.0 mA

Table 3-12: NAMUR Cassette Functions

Mode: dry on, high level alarm		Mode: wet on, low level alarm	
(-) (+) 1 2 $> 2.2 \text{ mA}$	(-) (+) 1 2 $< 1.0 \text{ mA}$	(-) (+) 1 2 $> 2.2 \text{ mA}$	(-) (+) 1 2 $< 1.0 \text{ mA}$
 LED on continuously	 LED flashes every second	 LED on continuously	 LED flashes every second

3.5.6 8/16 mA cassette

Figure 3-6: 8/16 mA Cassette (Dark Blue Label) – Code H

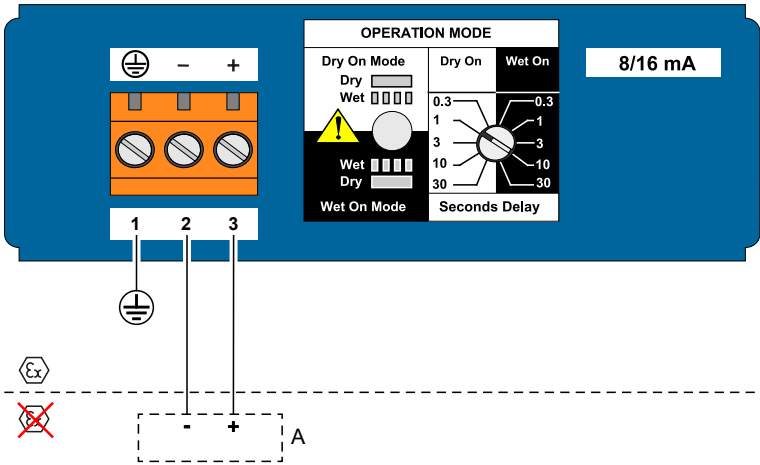

A. A certified intrinsically safe isolating amplifier to IEC 60947-5-6

Note

- This cassette is suitable for Intrinsically Safe (IS) applications and requires a certified isolating barrier. See the Rosemount 2120 [Product Certifications](#) document for Intrinsically Safe approvals.
- This electronics cassette is also suitable for non-hazardous (safe) area applications. In this case, U = 11 - 36 Vdc.
- It can only be interchanged with a NAMUR cassette.

Table 3-13: Electrical Parameters

Parameter	Value
U	24 Vdc Nominal
I _{ON}	15 - 17 mA
I _{OFF}	7.5 - 8.5 mA
I _{FAULT}	< 3.7 mA

Table 3-14: 8/16 mA Cassette Functions

Mode: dry on, high level alarm		Mode: wet on, low level alarm	
⊕ (-) (+) 1 2 3 	⊕ (-) (+) 1 2 3 	⊕ (-) (+) 1 2 3 	⊕ (-) (+) 1 2 3
 LED on continuously	 LED flashes every second	 LED on continuously	 LED flashes every second

3.6 Grounding

Make sure grounding is done according to national and local electrical codes. Failure to do so may impair the protection provided by the equipment.

3.6.1 Signal cable shield grounding

Make sure the instrument cable shield is:

- Trimmed close and insulated from touching the housing.
- Continuously connected throughout the segment.
- Connected to a good earth ground at the power supply end.

Figure 3-7: Signal Cable Shield Grounding at Power Supply End

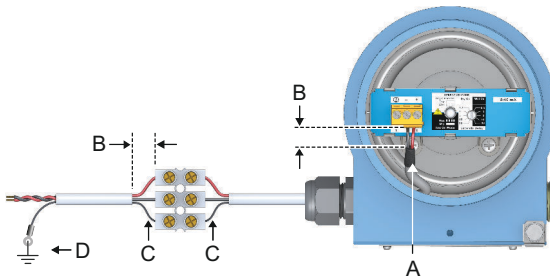

- A. Trim shield and insulate
- B. Minimize distance
- C. Trim shield
- D. Connect shield back to the power supply ground

3.6.2 Grounding the housing

The most effective grounding method for the metal housing is a direct connection to earth ground with minimal impedance. Housings with NPT conduit entries do not have an earth ground point and must use the fork earth.

Figure 3-8: Ground Screws

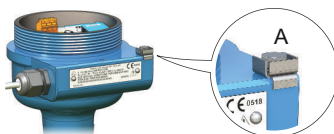

- A. External ground screw

4 Connect wiring and power up

Procedure

1. ⚠ Verify the power supply is disconnected.
2. Remove the field terminals cover.

In an explosion-proof/flameproof installation, do not remove the level switch cover when power is applied to the unit. The cover must also not to be removed in extreme environmental conditions.

- Versions of the Rosemount 2120 with a metal housing are explosion-proof/flameproof. They have a cover-lock to be undone first.

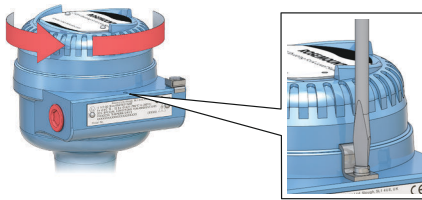

- Versions of the Rosemount 2120 with a glass-filled-nylon housing are not explosion-proof/flameproof. They do not have a cover-lock.

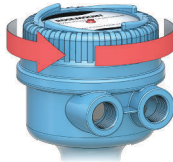

3. Remove the plastic plugs.

Versions of the Rosemount 2120 with a glass-filled-nylon housing do not have plastic plugs fitted.



4. Pull cables through the cable gland/conduits.

- Cassettes with a single terminal only require one cable.
Identification of thread size and type:

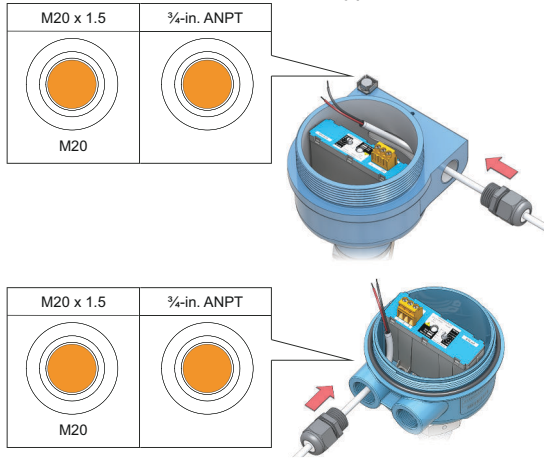

- Cassettes with two or more terminals may require more than one cable.

5. Connect the cable wires (see [Wiring diagrams](#) for other cassettes).

Metal housing:

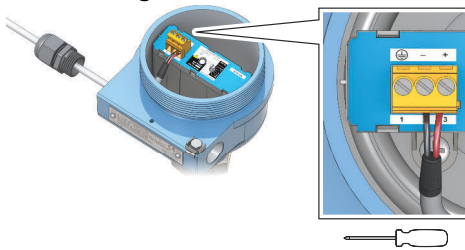

Glass-filled-nylon housing:

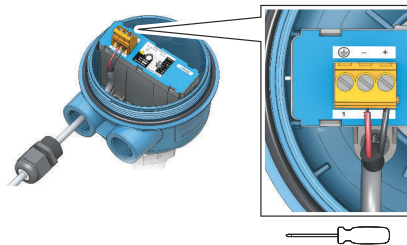

6. Ensure proper grounding.

- 7. Tighten the cable glands.
Apply PTFE tape or other sealant to the threads.
Metal housing:

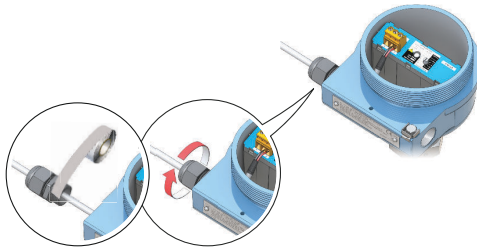

Glass-filled-nylon housing:

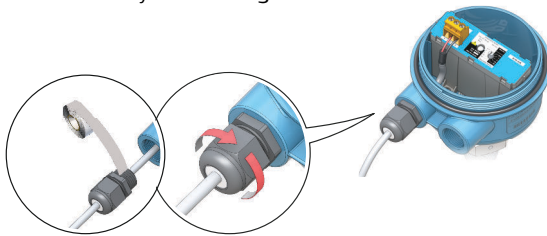

Note

Make sure to arrange the wiring with a drip loop.



- 8. Plug and seal the unused conduit connection to avoid moisture and dust accumulation inside the housing.
Apply PTFE tape or other sealant to the threads.

Metal housing:



Glass-filled-nylon housing:

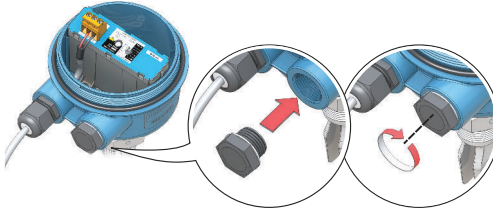

- 9. Attach and tighten the cover.
Make sure the cover is fully engaged.



- 10. ⚠ Required for explosion-proof/flameproof installations only:
The cover must be fully engaged to comply with explosion-proof requirements.
- 11. Re-lock the cover.

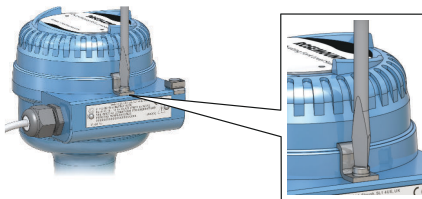

- 12. Connect the power supply.

5 Configuration

5.1 Output mode and time delay

All electronics cassettes have a rotating switch for setting the output to be "Dry On" (on when the fork is sufficiently dry) or "Wet On" (on when the fork is sufficiently wet).

The electronics uses hysteresis to help prevent constant switching of the output from dry-to-wet and wet-to-dry states due to splashing or intermediate conditions. To further prevent false switching, the rotating switch also sets a time delay of up to 30 seconds before the output changes.

A small cut-out in the rotating switch indicates the present mode and time delay.

Figure 5-1: Top-down View: Example Cassette Inside Housing

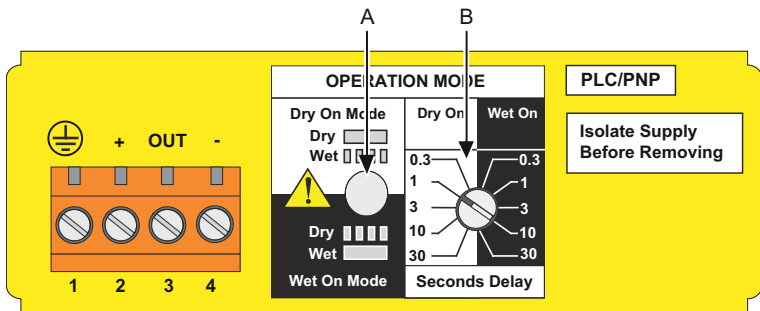

A. 'Heartbeat' LED

B. Rotating switch for setting output mode and time delay

The recommended mode for high level alarm installations is the "Dry On" mode (Figure 5-2).

Figure 5-2: Typical Settings for High Level Applications

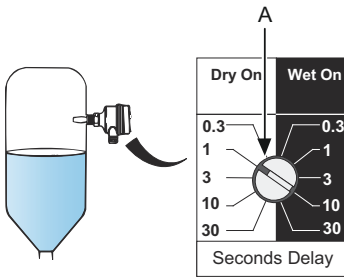

A. Mode "Dry On" and 1 second time delay

The "Wet On" mode is recommended for low level alarm installations (Figure 5-3).

Figure 5-3: Typical Settings for Low Level Applications

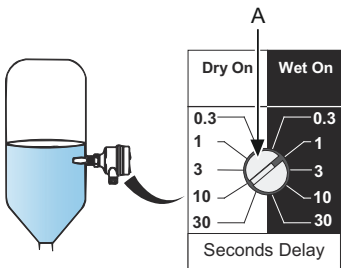

A. Mode "Wet On" and 1 second time delay

5.1.1 Set the mode switch and switching time delay

Procedure

1. Select "Dry on" or "Wet on" mode.
2. Select 0.3, 1, 3, 10, or 30 seconds for the delay before switching output state.

Note







There is a five second delay before changes to the mode and time delay become active.

6 Operation

6.1 LED indication status

Table 6-1 shows the different operation statuses and how they are indicated by the LED.

Table 6-1: LED Indications

	LED flash rate	Switch status
	Continuous	Output state is on.
	1 every second	Output state is off.
	1 every 2 seconds	Uncalibrated.
	1 every 4 seconds	Load fault; load current too high; load short circuit.
	2 times / second	Indication of successful calibration.
	3 times / second	Internal PCB fault.
	Off	Problem (e.g. supply).



Quick Start Guide
00825-0100-4030, Rev. GB
March 2022

For more information: [Emerson.com](https://www.emerson.com)

©2022 Emerson. All rights reserved.

Emerson Terms and Conditions of Sale are available upon request. The Emerson logo is a trademark and service mark of Emerson Electric Co. Rosemount is a mark of one of the Emerson family of companies. All other marks are the property of their respective owners.

ROSEMOUNT™

