

# Rosemount™ 2521 Solids Level Switch

## Vibrating Fork



CE

**Contents**

Introduction..... 3

Mechanical installation..... 10

Electrical installation..... 15

Configuration..... 24

Operation..... 29

Maintenance..... 33

# 1 Introduction

The level switch detects the presence and absence of a process media at its installation point, and reports it as a switched electrical output.

---

**Note**

Other language versions of this Quick Start Guide can be found at [Emerson.com/Rosemount](https://emerson.com/Rosemount).

---

## 1.1 Safety messages

### NOTICE

Read this manual before working with the product. For personal and system safety, and for optimum product performance, ensure you thoroughly understand the contents before installing, using, or maintaining this product.

For technical assistance, contacts are listed below:

---

#### Customer Central

Technical support, quoting, and order-related questions.

- United States - 1-800-999-9307 (7:00 am to 7:00 pm CST)
- Asia Pacific- 65 777 8211

#### North American Response Center

Equipment service needs.

- 1-800-654-7768 (24 hours a day — includes Canada)
- Outside of these areas, contact your local Emerson representative.

### ⚠ WARNING

#### Physical access

Unauthorized personnel may potentially cause significant damage to and/or misconfiguration of end users' equipment. This could be intentional or unintentional and needs to be protected against.

Physical security is an important part of any security program and fundamental to protecting your system. Restrict physical access by unauthorized personnel to protect end users' assets. This is true for all systems used within the facility.

---

**⚠ WARNING**

**Failure to follow safe installation and servicing guidelines could result in death or serious injury.**

- Ensure the level switch is installed by qualified personnel and in accordance with applicable code of practice.
- Use the level switch only as specified in this manual. Failure to do so may impair the protection provided by the level switch.

**Explosions could result in death or serious injury.**

- In explosion-proof/flameproof, increased-safety, and dust ignition-proof installations, do not remove the housing cover when power is applied to the level switch.
- The housing cover must be fully engaged to meet flameproof/explosion-proof requirements.

**Electrical shock could cause death or serious injury.**

- Avoid contact with the leads and terminals. High voltage that may be present on leads can cause electrical shock.
- Ensure the power to the level switch is off, and the lines to any other external power source are disconnected or not powered while wiring the level switch.
- Ensure the wiring is suitable for the electrical current and the insulation is suitable for the voltage, temperature, and environment.

**Process leaks could result in death or serious injury.**

- Ensure the level switch is handled carefully. If the process seal is damaged, gas or dust might escape from the silo (or other vessel)

**Any substitution of non-recognized parts may jeopardize safety. Repair (e.g. substitution of components) may also jeopardize safety and is not allowed under any circumstances.**

- Unauthorized changes to the product are strictly prohibited as they may unintentionally and unpredictably alter performance and jeopardize safety. Unauthorized changes that interfere with the integrity of the welds or flanges, such as making additional perforations, compromise product integrity and safety. Equipment ratings and certifications are no longer valid on any products that have been damaged or modified without the prior written permission of Emerson. Any continued use of product that has been damaged or modified without the written authorization is at the customer's sole risk and expense.

## ⚠ CAUTION

The products described in this document are NOT designed for nuclear-qualified applications.

- Using non-nuclear qualified products in applications that require nuclear-qualified hardware or products may cause inaccurate readings.
- For information on Rosemount nuclear-qualified products, contact your local Emerson Sales Representative.

Individuals who handle products exposed to a hazardous substance can avoid injury if they are informed of and understand the hazard.

- If the product being returned was exposed to a hazardous substance as defined by Occupational Safety and Health Administration (OSHA), a copy of the required Safety Data Sheet (SDS) for each hazardous substance identified must be included with the returned level switch.

## 1.2 Applications

A Rosemount 2521 Solids Level Switch is used for monitoring the level of bulk materials in all types of containers and silos.

The level switch can be used with all powdery and granulated bulk materials that do not show a strong tendency to form crusts or deposits. The detection of solids in a liquid is also possible.

Three different housing options are available:

- Standard
  - for installations in non-hazardous area (ordinary locations)
  - for dust-ignition proof installations in hazardous areas
- Type 'D'
  - for flameproof/explosion-proof/dust-ignition proof installations in hazardous areas (classified locations)
- Type 'DE'
  - same as Type 'D' but with a terminal box (increased safety)

Typical applications are:

- Building materials
  - Lime, extruded polystyrene foam (XPS), molding sand, etc.
- Food and beverage
  - Milk powder, flour, salt, etc.
- Plastics
  - Plastic granulates, etc.

- Timber
- Chemicals

The level switch has a threaded, flanged, or Tri Clamp process connection for mounting it onto a silo (or other vessel). You can mount it on a side wall of the silo, so that it is level with the filling limit to be monitored. Alternatively, if it has an extended length, mount it vertically on top of a silo to monitor the maximum filling limit.

The length of the fork can be up to 157.5 in. (4 m) with an extension tube or up to 787 in. (20 m) with an extension cable.

The use of a sliding sleeve is recommended so that the switching point can be changed easily during the live operation of the level switch.

---

**Note**

The Rosemount 2521 [Product Data Sheet](#) has all dimensional drawings.

---

**Figure 1-1: Typical Installation Examples**

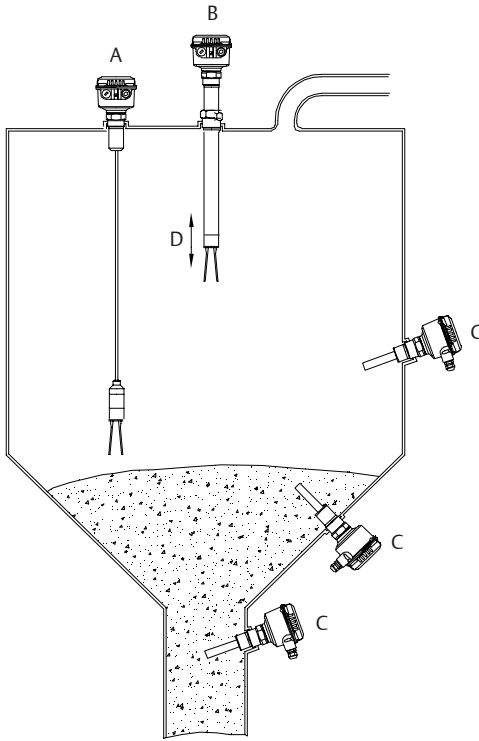

- A. Rosemount 2521 with the cable-extended fork length*
- B. Rosemount 2521 with the tube-extended fork length and thermal tube-extension*
- C. Rosemount 2521 with the standard length fork*
- D. Optional sliding sleeve*

**Figure 1-2: Detection of solids in water**

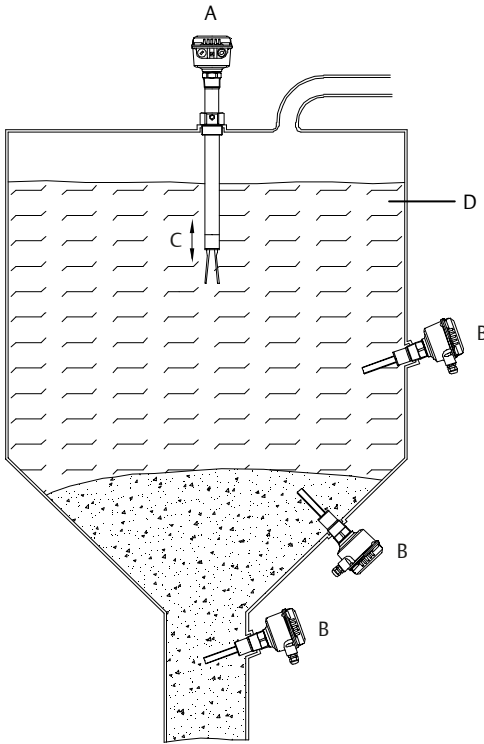

- A. Rosemount 2521 with the tube-extended fork length and thermal tube-extension
- B. Rosemount 2521 with the standard length fork
- C. Optional sliding sleeve
- D. Solids in water



## 1.3 Measurement principles

Using the principle of a tuning fork, a piezo-electric crystal oscillates the forks at their natural frequency. Changes to the oscillation frequency are continuously monitored by electronics which varies depending on whether the fork is covered or uncovered by a solids medium.

When the solids medium in the vessel (silo) falls away from the fork, it causes a change of oscillation frequency that is detected by the electronics and the output switches to indicate an 'uncovered' state.

When the solids medium in the vessel (silo) rises and covers the fork, it causes a change of oscillation frequency that is detected by the electronics and the output switches to indicate a 'covered' state.

The electrical output will vary depending on the electronics selected when the Rosemount 2521 was ordered.

## 2 Mechanical installation

### 2.1 Mounting considerations

Before mounting the level switch on a silo (or other vessel), review the safety and pre-mounting sections.

#### 2.1.1 Safety

##### General safety

1. Installation of this equipment shall be carried out by suitably trained personnel, in accordance with the applicable code of practice.
2. If equipment is likely to come into contact with aggressive substances, it is the user's responsibility to take suitable precautions that prevent it from being adversely affected, thus ensuring the type of protection is not compromised.
  - a. **Aggressive substances:** Acidic liquids or gases that may attack metals or solvents that may affect polymeric materials.
  - b. **Suitable precautions:** Regular checks as part of routine inspections or establishing from a material's data sheet that it is resistant to specific chemicals.
3. It is the responsibility of the installer to:
  - a. Take protective measures, such as fitting an angled shield (reverse V shape) to the silo or selecting an extension tube option, when there are high mechanical forces.
  - b. Ensure that the process connection is tightened by the correct amount of torque and sealed to prevent process leaks.
4. Technical data
  - a. The Rosemount 2521 [Product Data Sheet](#) has all the technical specifications. See [Emerson.com/Rosemount](#) for other language versions.

##### Hazardous area safety

The Rosemount 2521 [Product Certifications document](#) has safety instructions and control drawings for hazardous area installations. See [Emerson.com/Rosemount](#) for other language versions.

### 2.1.2 Solids in Water

The detection of solids in water is supported by the Rosemount 2521S only. An installation example can be seen in [Figure 1-2](#).

### 2.1.3 Mechanical load

The load at the mounting point must not exceed 300 Nm (Rosemount 2521 with an extended length fork).

**Figure 2-1: Maximum Mechanical Load**

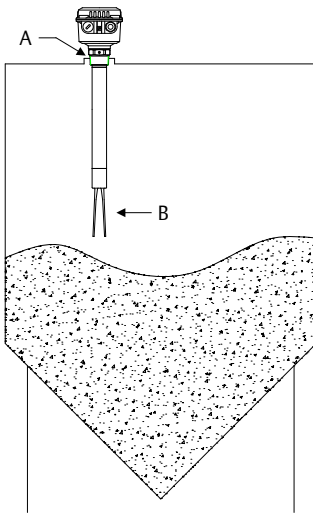

- A. Mounting point
- B. Mechanical load

### 2.1.4 Vertical installations

[Table 2-1](#) provides the maximum fork lengths and the corresponding maximum deviations from a normal vertical installation.

**Table 2-1: Maximum Vertical Deviation**

Maximum deviation	Maximum fork length
5°	157.5 in. (4000 mm)
45°	47.24 in. (1200 mm)
> 45°	23.62 in. (600 mm)

### 2.1.5 Mounting location

Take time to assess a suitable mounting location. Avoid mounting the level switch near the filling point, internal structures, and walls of a silo (or other vessel). When mounting the extended length versions of the level switch, it is especially important to consider internal structures. Forcing the level switch into a small or congested space risks damage to the sensor and could impair the protection it provides.

### 2.1.6 Sliding sleeve

Tighten both M8 screws with a torque of 20 Nm to establish a seal and maintain the process pressure. See [Figure 2-2](#).

**Figure 2-2: Sliding Sleeve, M8 Screws**

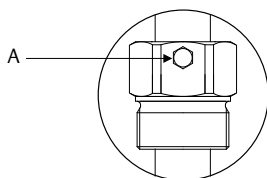

A. Two off M8 screws

### 2.1.7 Flange mounting

A suitable gasket must be fitted to provide a seal when the flanges are tightened.

### 2.1.8 Tightening threaded process connections

When tightening the threaded process connection of a Rosemount 2521:

- Use an open-ended wrench on the hexagonal boss of the level switch or the sliding sleeve.
- Never tighten by using the housing.
- Do not exceed the maximum torque of 80 Nm.

### 2.1.9 Hygienic applications

The food-grade materials are suitable for use under normal and predictable hygienic applications (according to directive 1935/2004 Art.3). There are currently no hygienic certifications for the Rosemount 2521.

### 2.1.10 Vibrating forks

Bending, shortening, or extending the forks will damage the level switch.

### 2.1.11 Rotatable housing and fork orientation mark

The standard housing can be freely rotated to get the best position after being mounted to a process. On type 'D' and 'DE' housings, a fixing screw must first be loosened before the housing can be freely rotated. When the best position is achieved, re-tighten the fixing screw. Never force the rotation of the housing beyond the physical limits.

**Figure 2-3: Housing Rotation and Fork Orientation Mark**

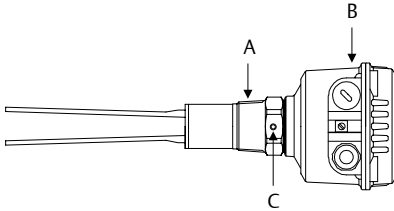

- A. Threaded process connection
- B. Housing
- C. Fork orientation mark on hexagonal boss (or sliding sleeve if fitted)

### 2.1.12 Orientation of cable glands

When the level switch is mounted horizontally, ensure the cable glands are pointed downwards to avoid water getting inside the housing. Unused conduit entries must be completely sealed with a suitably rated stopping (blanking) plug.

### 2.1.13 Seals

Apply PTFE tape to the threaded process connection. This is required for a silo (or other vessel) to maintain the process pressure.

### 2.1.14 Future maintenance

It is advisable to grease the screws of the housing cover (lid) when a corrosive atmosphere is present. This will help prevent difficulties when the cover needs to be removed during future maintenance tasks.

### 2.1.15 Switching point

#### Heavy bulk materials

The signal output switches over when the forks of the level switch are covered a few millimeters.

## Light bulk materials

The signal output switches over when the forks of the level switch are covered a few centimeters.

## 2.2 Mounting the level switch

Figure 2-4 shows how the level switch should be mounted.

**Figure 2-4: Correct and Incorrect Mounting**

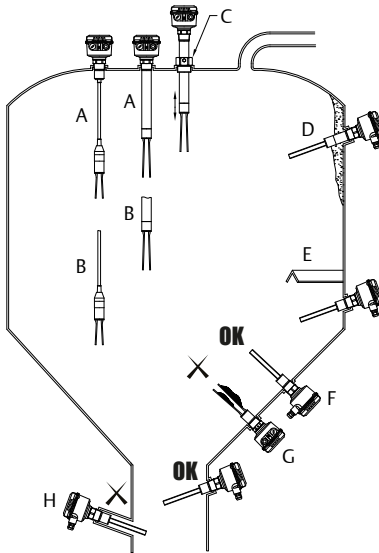

- A. Full-silo detection using the cable-extended fork length option
- B. Empty-silo detection using the cable-extended or tube-extended fork length option
- C. Sliding sleeve option
- D. Bulk solids slide downwards more easily when the device is mounted at an angle (recommended)
- E. Steel protection shield
- F. Installation in the conical part is only suitable for solids material (powder) that will not build-up on the forks
- G. Incorrect installation - the fork orientation is not allowing solids material to pass between the forks. Check the orientation mark on the hexagon is either facing upwards or downwards
- H. Incorrect installation - the socket is too long and allows the solids material to easily accumulate inside it. The forks must protrude into the silo sufficiently to correctly detect the level

## 3 Electrical installation

### 3.1 Safety messages

#### **⚠ WARNING**

**Failure to follow safe installation and servicing guidelines could result in death or serious injury.**

- Ensure the level switch is installed by qualified personnel and in accordance with applicable code of practice.
- Use the level switch only as specified in this manual. Failure to do so may impair the protection provided by the level switch.

**Explosions could result in death or serious injury.**

- In explosion-proof/flameproof, increased-safety, and dust ignition-proof installations, do not remove the housing cover when power is applied to the level switch.
- The housing cover must be fully engaged to meet flameproof/explosion-proof requirements.

**Electrical shock could cause death or serious injury.**

- Avoid contact with the leads and terminals. High voltage that may be present on leads can cause electrical shock.
- Ensure the power to the level switch is off, and the lines to any other external power source are disconnected or not powered while wiring the level switch.
- Ensure the wiring is suitable for the electrical current and the insulation is suitable for the voltage, temperature, and environment.

---

### 3.2 Wiring considerations

#### **Note**

See the Rosemount 2521 [Product Data Sheet](#) for the full electrical specifications.

---

#### 3.2.1 Handling

In cases of improper handling or handling malpractice, the electrical safety of the device cannot be guaranteed.

### 3.2.2 Installation regulations

Local regulations or VDE 0100 (Regulations of German Electrotechnical Engineers) must be observed.

When using 24 V supply voltage, an approved power supply with reinforced insulation to mains is required.

### 3.2.3 Fuse

Use a fuse as stated in the connection diagrams.

### 3.2.4 Residual Current Circuit Breaker (RCCB) protection

In case of a defect, the distribution voltage must automatically be cut-off by an RCCB protection switch to protect against indirect contact with dangerous voltages.

### 3.2.5 Power supply

#### **Power supply switch**

A voltage disconnection switch must be provided near the device.

#### **Supply voltage**

Compare the supply voltage applied with the specifications given on the electronic module and nameplate before switching on the device.

### 3.2.6 Wiring

#### **Field wiring cables**

The diameter has to match the clamping range of the used cable gland.

The cross-section has to match the clamping range of the connection terminals and the maximum current must be considered.

All field wiring must have insulation suitable for at least 250 Vac.

The temperature rating must be at least 194 °F (90 °C).

Use a shielded cable when there are electrical interferences present that are higher than stated in the EMC standards. Otherwise, an unshielded instrumentation cable can be used.

#### **Guiding the cables in the terminal box**

The field wiring cables must be cut to a length to be able to properly fit them into the terminal box.

#### **Connection terminals**

When preparing cable wires for connection to terminals in a standard or type 'D' housing, the wire insulation must be stripped to show no more than 0.31



in. (8 mm) of the copper strands. For Type 'DE' housings, remove insulation of no more than 0.35 in. (9 mm). Always check that the power supply is disconnected or switched-off to avoid coming into contact with dangerous live parts.

### Connection terminals

When preparing cable wires for connection to terminals, the wire insulation must be stripped to show no more than 0.31 in. (8 mm) of the copper strands. Always check that the power supply is disconnected or switched-off to avoid coming into contact with dangerous live parts.

## 3.2.7 Cable glands, conduits, and blanking plugs in hazardous area installations

### General installation

- Installation of this equipment shall be carried out by suitably trained personnel, in accordance with the applicable code of practice.
- Seal the un-used conduit entries with a suitably rated blanking plugs.
- Use only factory-supplied parts, where applicable.
- A suitable strain-relief must be provided for the wiring cables when the level switch is installed with the factory-supplied cable glands.
- The diameter of the wiring cable must match to the clamping range of the cable clamp.
- For parts that are not factory-supplied, it is the responsibility of the installer to ensure:
  - The parts have a certification and type of protection that is equivalent to the approval of the level switch.
  - The parts have an ambient temperature range that complies with the specification of the level switch plus 10 Kelvin.
  - The parts must be installed in accordance with the installation instructions of the part manufacturers.

### Installation of a flameproof or explosion-proof Rosemount 2521 with a conduit system

In a conduit system, single electric conductors are installed in a certified pipe system. This pipe system must also have a flameproof or explosion-proof construction.

For ATEX and IECEx approvals, both enclosure of the level switch and pipe system need to be isolated from each other by using a certified flameproof or explosion-proof seal. The seal must be installed directly in, or at, the conduit entries of the level switch. Unused conduit entries must be sealed using suitably certified blanking elements (stopping plugs).

For FM and CSA approvals, both enclosure of the level switch and pipe system need to be isolated from each other by using a certified flameproof seal. The seal must be installed within 18 inches of the enclosure wall. Unused conduit entries must be sealed using suitably certified blanking elements (stopping plugs).

### 3.2.8 Relay and transistor protection

Provide protection for relay contacts and output transistors to protect the device against inductive load surges.

### 3.2.9 Static charging

The Rosemount 2521 must be grounded to avoid a static electrical build-up. This is particularly important for applications with pneumatic conveying and non-metallic containers.

## 3.3 Wiring the level switch

**Figure 3-1: Connections Overview for Standard and Type 'D' Housings**

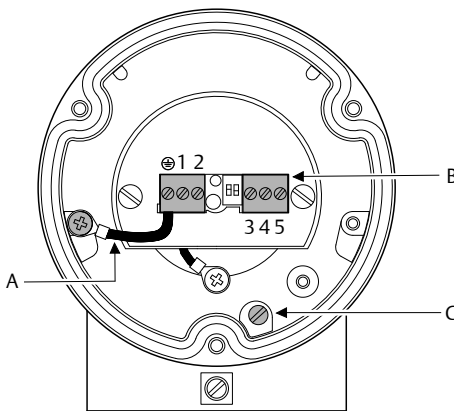

- A. Internal ground terminal - electronics connected to housing
- B. Connection terminals
- C. Protective conductor terminal - Protective Earth (PE)

**Figure 3-2: Connections Overview for Type 'DE' Housings**

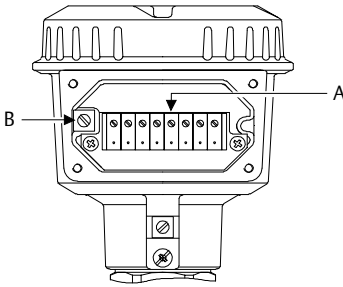

- A. Connection terminals (in a terminal box for increased safety).  
The fixing torque is 0.5 - 0.6 Nm
- B. Protective conductor terminal - Protective Earth (PE)

### 3.3.1 Wiring the SPDT relay

Power supply:

- 19 to 230 Vac (50/60 Hz) +10% 8 VA
- 19 to 55 Vdc +10% 1.5 W

Signal output (floating SPDT relay):

- Maximum 250 Vac, 8 A, non-inductive
- Maximum 30 Vdc, 5 A, non-inductive

Fuse on signal output: maximum 10 A, slow or fast, HBC, 250 V

**Figure 3-3: SPDT Power Supply and Signal Output Connections**

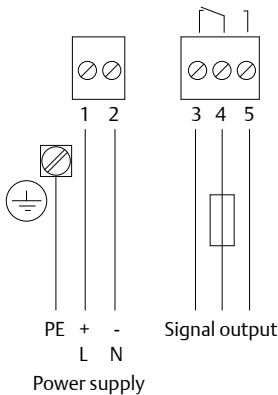

### 3.3.2 Wiring the DPDT relay

Power supply:

- 19 to 230 Vac (50/60 Hz) +10%, 18 VA
- 19 to 36 Vdc (for I.S. approvals) or to 55 Vdc +10%, 2 W

Signal output (floating DPDT relay):

- Maximum 250 Vac, 8 A, non-inductive
- Maximum 30 Vdc, 5 A, non-inductive

Fuse on signal output: maximum 10 A, slow or fast, HBC, 250 V

**Figure 3-4: DPDT Power Supply and Signal Output Connections**

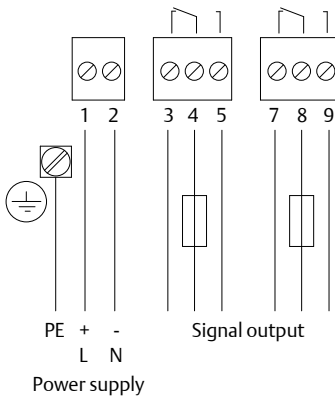

### 3.3.3 Wiring for 3-wire PNP

Power supply:

- 18 to 50 Vdc +10%, 1.5 W

Signal output:

- Maximum 0.4 A
- Load in example from PLC, relay, bulb, etc.

Fuse on power supply: maximum 4 A, slow or fast, HBC, 250 V

**Figure 3-5: 3-Wire PNP: Power Supply and Signal Output Connections**

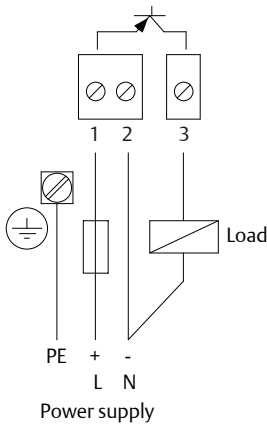

### 3.3.4 2-Wire without Contact

Power supply:

- 19 to 230 Vac (50/60 Hz) +10%, 1.5 VA
- 19 to 230 Vdc +10%, 1 W

Load:

- Minimum 10 mA
- Maximum 0.5 A (fixed)
- Load in example from PLC, relay, bulb, etc.

Fuse on power supply: maximum 4 A, slow or fast, HBC, 250 V

---

**Note**

See the Rosemount 2521 [Product Data Sheet](#) for the full electrical specifications.

---

**Figure 3-6: 2-Wire: Power Supply and Load Connections**

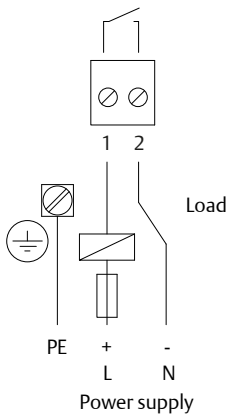

### 3.3.5 Wiring for NAMUR (IEC 60947-5-6)

Power supply:

- 7 to 9 Vdc

Signal output:

- < 1 mA or > 2.2 mA switched output

---

**Figure 3-7: NAMUR Power Supply and Signal Output Connections**

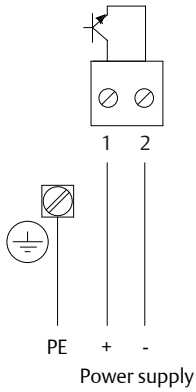

## 4 Configuration

### 4.1 Configuring the signal output (FSH and FSL)

Fail Safe High (FSH) and Fail Safe Low (FSL) configurations are supported on the following electronic modules:

- SPDT relay
- DPDT relay
- 3-wire PNP
- 2-wire without contact

Figure 4-1 shows the SPDT relay electronics module as an example. The other modules have the same configuration switch and default setting.

#### FSH signal output

When the level switch is used to indicate full-silo, set to **Fail Safe High**. A power failure or line break is regarded as full-silo signal (as protection against overfilling).

#### FSL signal output

When the level switch is used to indicate empty load, set to **Fail Safe Low**. A power failure or line break is regarded as empty-silo signal (as protection against running dry).

**Figure 4-1: FSL and FSH Settings**

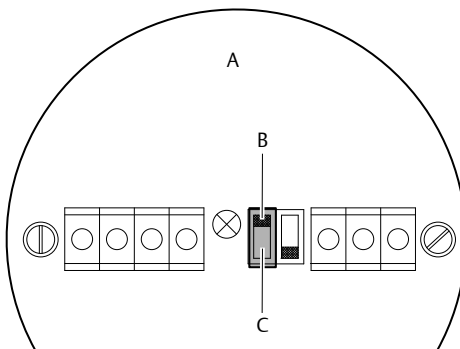

- A. SPDT relay electronics module
- B. FSL setting (switch position up)
- C. FSH setting (switch position down)



## 4.2 Configuring the signal output delay

The two rotary switches (potentiometers) on the DPDT relay electronics are used for configuring delays of up to 30 seconds before the output signal changes. This feature can help prevent false switching of outputs caused by temporary movements of solids during filling or emptying operations.

By default, T1 and T2 are configured for 0 seconds (no delays).

Turning the T1 potentiometer clockwise increases the time delay for when the output switches from a sensor covered -> free state.

Turning the T2 potentiometer clockwise increases the time delay for when the output switches from free -> sensor covered.

---

**Figure 4-2: Delay Settings**

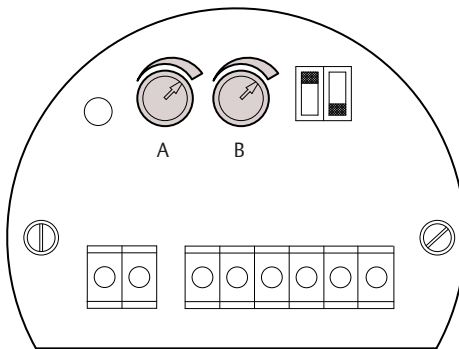

A. Potentiometer T1

B. Potentiometer T2

---

## 4.3 Configuring the signal output fail-safe (Rising or Falling)

The NAMUR electronics indicates a covered or uncovered fork sensor state by one of two switched output currents and the on-board LED. As a fail-safe, the PCB can be configured to indicate either state when there is a fault.

### Falling arrow fail-safe

When the Rosemount 2521 is used to indicate a full-silo, set the PCB switch to the Falling Arrow fail-safe position. A power failure or line break is regarded as a full-silo signal (for protection against overfilling).

### Rising arrow fail-safe

When the Rosemount 2521 is used to indicate an empty load, set the PCB switch to the Rising Arrow fail-safe position. A power failure or line break is regarded as an empty-silo signal (as protection against running dry).

**Figure 4-3: Rising and Falling Fail Safe Settings**

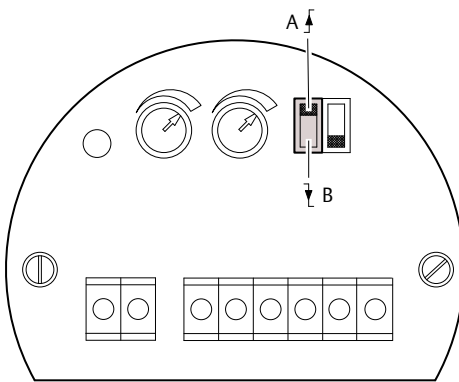

- A. *Rising Arrow fail-safe (switch position up)(default)*
- B. *Falling Arrow fail-safe (switch position down)*

## 4.4 Configuring the sensitivity

The level switch is factory-set to high sensitivity (setting B) and normally does not need to be changed. However, if the bulk solids material has a frequent tendency to cake or deposit, a switch on the PCB can be changed to setting A to decrease the sensitivity of the fork sensor.

Figure 4-4 shows the SPDT relay electronics module as an example. The other modules have the same configuration switch and default setting.

**Figure 4-4: Sensitivity Settings**

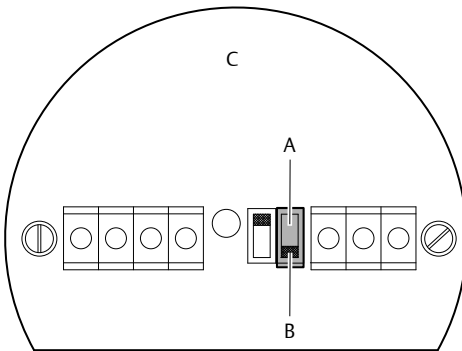

- A. Low sensitivity setting A (switch position up)
- B. High sensitivity setting B (switch position down) - factory default
- C. Electronics PCB for the SPDT relay option

**Table 4-1: Approximate minimum bulk density on setting**

	<b>Setting A Low sensitivity</b>	<b>Setting B High sensitivity</b>
Rosemount 2521S (standard sensitivity)	9 lb/ft <sup>3</sup> (150 g/l)	3 lb/ft <sup>3</sup> (50 g/l)
Rosemount 2521H (high sensitivity, option V1)	4.5 lb/ft <sup>3</sup> (75 g/l)	1.2 lb/ft <sup>3</sup> (20 g/l)
Rosemount 2521H (enhanced sensitivity, option V2 or V3 <sup>(1)</sup> )	1.2 lb/ft <sup>3</sup> (20 g/l)	0.3 lb/ft <sup>3</sup> (5 g/l)

(1) Sensitivity option V3 is more sensitive than option V2 by having an increased surface area on the fork.

For measurement of solids in water using a Rosemount 2521S, setting A is recommended. Sensitivity adjustments to the electronics can also be made using the potentiometer.

### Interface measurement option

Versions of the Rosemount 2521 with a single rotary switch (potentiometer) on the electronics PCB can support interface measurements.

Turn potentiometer towards **Min**: Vibrating fork gets less sensitive.

Turn potentiometer towards **Max**: Vibrating fork gets more sensitive.

**Figure 4-5: Sensitivity Settings with Potentiometer**

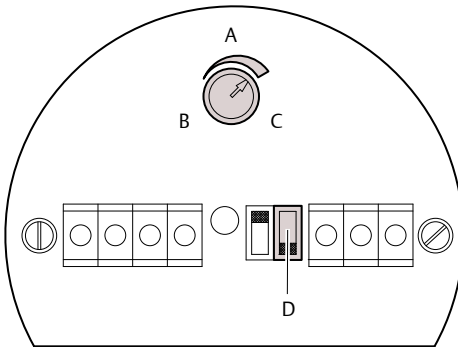

- A. Potentiometer for adjusting the sensitivity
- B. Minimum sensitivity
- C. Maximum sensitivity
- D. Sensitivity setting is not possible

## 5 Operation

### 5.1 Signal output switching logic (FSH or FSL)

**Figure 5-1: Switching Logic (All Versions Except NAMUR)**

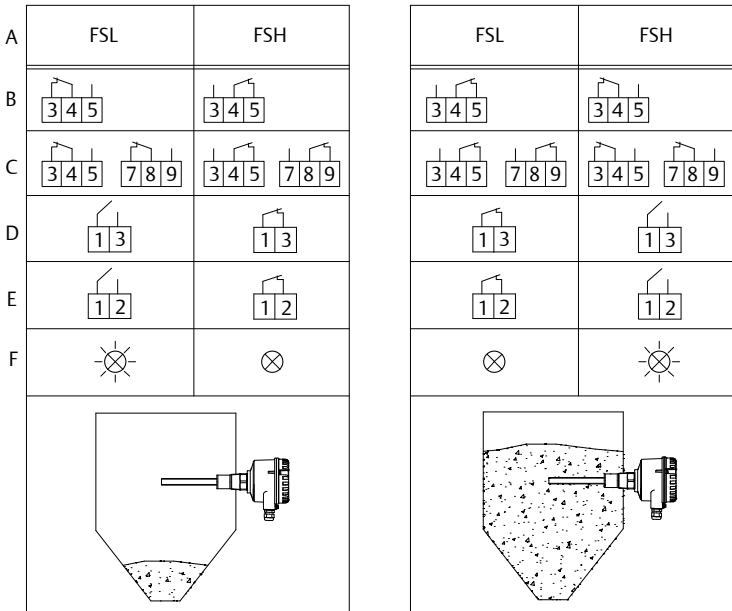

- A. Setting: Fail Safe High or Fail Safe Low
- B. SPDT relay electronics
- C. DPDT relay electronics
- D. 3-wire PNP electronics
- E. 2-wire electronics
- F. LED for output signal

**Note**

See [Configuring the signal output \(FSH and FSL\)](#) for how to select a FSH or FSL setting.

## 5.2 Signal output from NAMUR (switching logic)

**Figure 5-2: Switching Logic (NAMUR Only)**

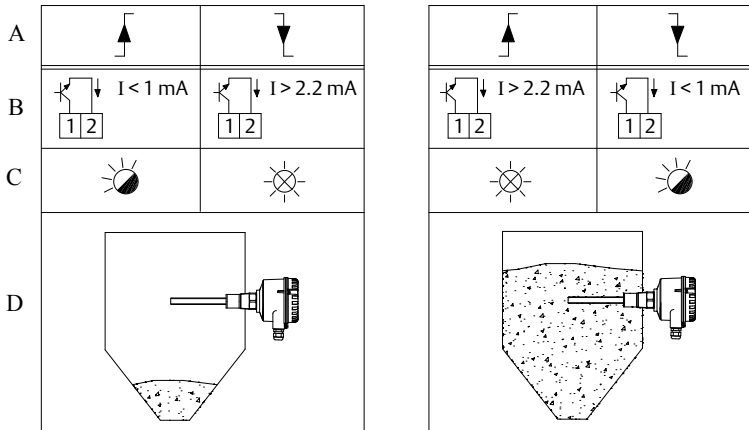

- A. Setting: Rising or Falling fail-safe
- B. NAMUR electronics (IEC 60947-5-6)
- C. LED for output signal
- D. Uncovered and covered fork sensors

**Note**

See [Configuring the signal output fail-safe \(Rising or Falling\)](#) for how to select a Rising or Falling fail-safe setting.

### 5.3 LED for signal output

---

**Figure 5-3: LED Visible On PCB**

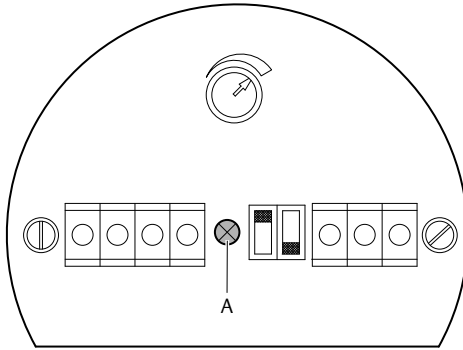

A. LED

---

### 5.4 Test button for diagnostics

Versions of the Rosemount 2521 with NAMUR electronics can be tested for vibration anomalies and electronic malfunctions while installed in a silo or other storage vessel. A test button is on the electronic PCB (see [Figure 5-4](#)).

---

**Figure 5-4: Location of Test Button**

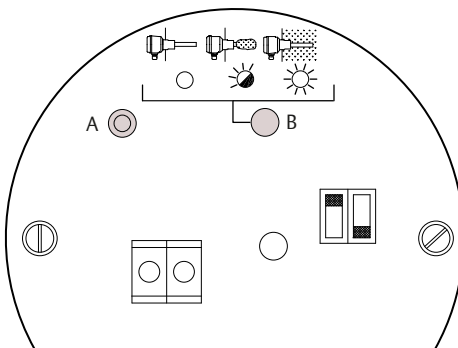

A. Test button  
B. LED for diagnostics

---

When the fork is not covered with solids material, pressing the test button stops the vibration and the signal output switches to indicate a covered fork sensor state.

When the fork is covered with solids material, the test button has no effect.

## 5.5 LED for diagnostics

Versions of the Rosemount 2521 with NAMUR electronics have a LED for indicating diagnostics while installed in a silo or other storage vessel. The LED is on the electronic PCB (see [Figure 5-5](#)).

When the LED is off, the fork sensor is measuring normal strong vibrations. This indicates the fork is clean and switching the output signal as expected.

When the LED is blinking, the fork sensor is measuring weak vibrations. A gradual decrease in the vibration indicates a possible increase in the build-up of solids material on the fork. If the LED continues to blink after cleaning the fork, try a higher sensitivity setting.

When the LED is constantly on, the vibration has stopped. This indicates the fork is fully covered by solids material.

**Figure 5-5: Location of Diagnostics LED**

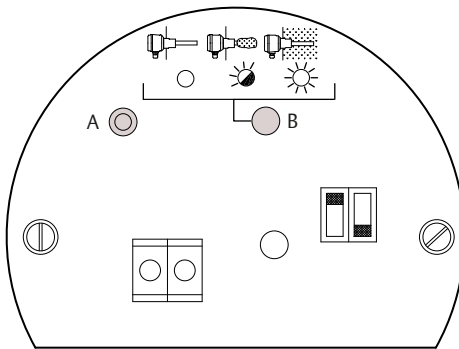

- A. Test button
- B. LED for diagnostics



## 6 Maintenance

### 6.1 Opening the lid (cover)

Before opening the lid for maintenance reasons, consider the following:

- Check the certifications on the product label and then review [Table 6-1](#).
- Review the section [Safety](#).
- Ensure that no dust deposits or airborne dusts are present.
- Ensure that rain does not enter the housing.

**Table 6-1: Check Before Opening Lid**

Protection	Safety information
No protection	Do not remove the lid while circuits are alive.
Flameproof or gas explosion-proof (type D housing)	To prevent ignition of hazardous atmospheres, do not remove the lid while circuits are alive.
Dust explosion-proof	To prevent dust explosions, do not remove the lid while circuits are alive.
Intrinsic safety	If NAMUR electronics is fitted, the lid can be removed while circuits are alive.

### 6.2 Regular checks for safety

To ensure robust safety in hazardous locations and with electrical safety, the following items must be regularly checked depending on the application:

- Mechanical damage or corrosion of the field wiring cables or any other components (housing side and sensor side).
- Tight sealing of the process connection, cable glands, and enclosure lid.
- Properly connected external PE cable (if present).

### 6.3 Cleaning

If cleaning is required by the application, following must be observed:

- Cleaning agent must comply with the materials of the unit (chemical resistance). Mainly the shaft sealing, lid sealing, cable gland and the surface of the unit must be considered.

The cleaning process must be done in a way, that:

- The cleaning agent cannot enter into the unit through the shaft sealing, lid sealing or cable gland.

- No mechanical damage of the shaft sealing, lid sealing, cable gland or other parts can happen.

---

**Note**

An accumulation of dust on the housing does not increase the surface temperature. However, dust can be safely removed with a damp cloth. Never use a dry cloth because it may cause an electrostatic discharge. See the Rosemount 2521 [Product Certifications document](#) for the maximum surface temperatures in hazardous area (classified locations) applications.

---

## 6.4 Function test

A frequent function test may be required depending on the application.

Observe all relevant safety precautions related to work safety (e.g. electrical safety, process pressure, etc).

This test does not prove if the level switch is sensitive enough to measure the material of the application.

Function tests are done by covering the forks with a suitable solids material and monitoring if a correct change of the signal output from uncovered to covered happens.

## 6.5 Production date

The production year is shown on the nameplate.

## 6.6 Spare parts

Refer to the Rosemount 2521 [Product Data Sheet](#) for all spare parts.





### Emerson Automation Solutions

6021 Innovation Blvd.  
Shakopee, MN 55379, USA

 +1 800 999 9307 or +1 952 906 8888

 +1 952 949 7001

 RFQ.RMD-RCC@Emerson.com

### Latin America Regional Office

Emerson Automation Solutions  
1300 Concord Terrace, Suite 400  
Sunrise, FL 33323, USA

 +1 954 846 5030

 +1 954 846 5121

 RFQ.RMD-RCC@Emerson.com

### Asia Pacific Regional Office

Emerson Automation Solutions  
1 Pandan Crescent  
Singapore 128461

 +65 6777 8211

 +65 6777 0947

 Enquiries@AP.Emerson.com

 [Linkedin.com/company/Emerson-Automation-Solutions](https://www.linkedin.com/company/Emerson-Automation-Solutions)

 [Twitter.com/Rosemount\\_News](https://twitter.com/Rosemount_News)

 [Facebook.com/Rosemount](https://www.facebook.com/Rosemount)

 [Youtube.com/user/RosemountMeasurement](https://www.youtube.com/user/RosemountMeasurement)

### North America Regional Office

Emerson Automation Solutions  
8200 Market Blvd.

Chanhassen, MN 55317, USA

 +1 800 999 9307 or +1 952 906 8888

 +1 952 949 7001

 RMT-NA.RCCRFQ@Emerson.com

### Europe Regional Office

Emerson Automation Solutions Europe  
GmbH

Neuhofstrasse 19a P.O. Box 1046

CH 6340 Baar

Switzerland

 +41 (0) 41 768 6111

 +41 (0) 41 768 6300

 RFQ.RMD-RCC@Emerson.com

### Middle East and Africa Regional Office

Emerson Automation Solutions

Emerson FZE P.O. Box 17033

Jebel Ali Free Zone - South 2

Dubai, United Arab Emirates

 +971 4 8118100

 +971 4 8865465

 RFQ.RMTMEA@Emerson.com

©2020 Emerson. All rights reserved.

Emerson Terms and Conditions of Sale are available upon request. The Emerson logo is a trademark and service mark of Emerson Electric Co. Rosemount is a mark of one of the Emerson family of companies. All other marks are the property of their respective owners.