

# Rosemount™ CT4215 Leak Detection System



## Preface

Published by Emerson™.

All possible care has been taken in the preparation of this publication, but Emerson™ and its agents and distributors accept no liability for any inaccuracies that may be found. This manual reflects the state of the product at the issue date below, but further enhancements while in service may mean that the manual does not reflect your particular system. This quick start guide reflects the state of the product at the issue date below, but further enhancements while in service may mean that the manual does not reflect your particular system.

Emerson reserves the right to make changes without notice both to this publication and the products which it describes.

Document number: 00825-0100-4245

Rev AB, July 2018

© Emerson 2018. All rights reserved.

No part of this publication may be reproduced, stored in a retrieval system, or transmitted in any form or by any means electronic, mechanical, photocopying, recording, or otherwise without the express prior written permission of the copyright holder.

If you require additional technical assistance, request help from ([cascade.support@emerson.com](mailto:cascade.support@emerson.com)) or Emerson distribution partners.

General inquiries should be sent to [cascade.support@emerson.com](mailto:cascade.support@emerson.com).

All trademarks used within this document are the property of their respective owners.

## Important information

---

### Important

Users must read, understand, and comply with the following information before proceeding.

---

All users, installers, operators, and maintainers must be familiar with operating the detector. To install, start up, operate, maintain, and service the detector in a safe manner, it is MANDATORY to read all additional instruction manuals shipped with the detector. The following instruction manual(s) are available and / or referenced within this manual:

Rosemount™ CT4215 Reference Manual: 00809-0100-4245

## User information

---

### Important

All users must read this page before proceeding!

---

Emerson™ designs, manufactures, and tests its products to meet many national and international standards. The Rosemount™ CT4215 is a sophisticated technical product, and to ensure it continues to operate as designed and within normal specifications, it MUST be installed, used, and maintained correctly. The following instructions MUST be adhered to and integrated into your safety program when installing, using, and maintaining Rosemount™ products.

- Failure to follow the proper instructions may cause:
  - Loss of life
  - Personal injury
  - Damage to property
  - Damage to this instrument
  - Warranty invalidation
- Read all instructions prior to installing, operating, and servicing the product.
- If you do not understand any of the instructions, contact your Rosemount™ representative for clarification.
- Follow all warnings, cautions, and instructions marked on and supplied with the product.
- Inform and educate your personnel in the proper installation, operation, and maintenance of the product.
- Install your equipment as specified in the installation instructions of the appropriate manual and in accordance with applicable local and national codes.
- Connect all products to the proper electrical and pressure sources.
- To ensure proper performance, use qualified personnel to install, operate, update, program, and maintain the product.
- When replacement parts are required, ensure that qualified people use replacement parts specified by Emerson™.
- Unauthorized parts and procedures can affect the product's performance, place the safe operation of your process at risk, and VOID YOUR WARRANTY. Look-alike substitutions may result in fire, electrical hazards, or improper operation.
- To prevent electrical shock and personal injury, all equipment doors must be closed and protective covers in place, except when maintenance is being performed by qualified personnel.
- The information contained in this document is subject to change without notice.

### General safety notice/residual risk

Installation, operation, and maintenance of the detector must be in accordance with these instructions.

When operated as intended and all applicable safety instructions are observed, an element of risk will remain, including, but not limited to, the following:

- Explosion protection measures may become ineffective on the occurrence of one failure (for Category 3 instruments).
- The emission of gases hazardous to health may be possible when all gas connections have been correctly made.

To avoid exposure to the dangers of residual risks, take particular care when installing, operating, maintaining, and servicing the detector.

### Authorized personnel

In-depth specialist knowledge is an absolute requirement for working with and on the detector. Personnel installing, operating, servicing, and maintaining the detector must be instructed, trained, qualified, and authorized for hazardous areas with the operating company and the manufacturer. It is the operating company's responsibility to:

- Train staff.
- Observe safety regulations.
- Follow the safety instructions and procedures in the product manual.

Operators must:

- Be trained.
- Read and understand all relevant sections of the product manual before commencing work.
- Know the safety mechanisms and regulations.

### **WARNING!**

**To avoid explosions, loss of life, personal injury, and damage to this equipment and on-site property, do not install, operate, maintain, or service this instrument before reading and understanding this instruction manual and receiving appropriate training.**

## Regulations and standards

Regulations / Standards	Description
2014/35/EU	The Low Voltage Directive
2014/30/EU	The Electromagnetic Compatibility Directive
2012/19/EU	Waste Electrical and Electronic Equipment (WEEE) Directive
USA 21 CFR 1040.1	Laser products
BS EN 60825-1	Safety of laser products. Equipment classification and requirements (identical to IEC 608250-1 2007)
BS EN 61010-1 2010 IEC 61010-1 2010	Safety requirements for electrical equipment for measurements, control, and laboratory use. General requirements
BS EN 61326-1: 2013	Electrical equipment for measurement, control, and laboratory use. EMC requirements. General requirements

## Associated publications

Quick Start Guide: D-7010-0055

## Compliance approvals



This product complies with USA 21 CFR 1040.10.

This product is designed and manufactured under an approved quality management system to ISO 9001: 2008.

Emerson and the detector have satisfied the requirements for applying the CE marking to the detector.

This equipment meets all requirements of the EMC and Low Voltage directives.

## Waste disposal



Do not dispose of measuring tools into household waste.

Only for EC countries:

In accordance with European Directive 2012/19/EU for Waste Electrical and Electronic Equipment and its implementation into national right, measuring tools that are no longer usable must be collected separately and disposed of in an environmentally correct manner.

## Safety and information notices

This article is in accordance with IEC 60079-0: 2011 Clause 30. This article must not be changed amended or removed.

### **DANGER!**

WILL CAUSE DEATH

Failure to follow this warning will result in death or serious injury to personnel.

---

### **WARNING!**

DANGER TO PERSONNEL

Failure to follow this warning may result in serious injury to personnel.

---

### **CAUTION!**

MAY CAUSE DAMAGE TO EQUIPMENT

Failure to follow this warning may result in damage to the equipment.

---

### **NOTICE**

Important or tip messages will appear in this format.

---

## Safety Information

All authorized users, including installation, operation, and maintenance personnel, must observe the following safety precautions and warnings.

### **DANGER!**

#### ELECTRIC SHOCK

The detector operates using mains voltage that is dangerous to life. Make sure that the circuit breakers are set to *OFF* and tagged off before removing the top cover or opening the front cover.

Failure to observe this precaution will cause death, personal injury, and/or damage to persons and/or property.

---

### **WARNING!**

#### OPTICAL RADIATION EXPOSURE HAZARD

The detector contains lasers. Opening the detector and attempting to perform adjustments and procedures other than those specified in this manual may result in hazardous optical radiation exposure.

All lasers within the detector are Class 1. The emitted laser light is invisible (mid-infrared) and the combined laser powers are sufficiently low at the first accessible aperture that the unprotected eye will not be damaged. This class is eye safe under all operating conditions.

It is, however, possible to cause damage to the eye through not following correct procedures. Do not look at the laser with any kind of magnifier or optical measuring device.

---

### **WARNING!**

#### HAZARDOUS SUBSTANCES

The detector may contain hazardous substances. Always handle the detector assemblies and components with extreme caution.

Gas handling components within the detector will contain particulate matter from the sample gases. Over the life of the detector, the concentration of particulate matter will become enriched within the gas handling components. When performing repairs and maintenance on the detector:

- Handle used gas handling components with extreme caution.
- Avoid direct skin contact with used gas handling components.
- Do not smoke, drink, or eat in the work area.
- Wear goggles or eye shields.
- Wear a suitable face mask to protect against inhalation of particulate matter.
- Do not wet fingers, eyes, or any exposed skin.
- Pack used gas handling components for disposal in sealed packaging and label them *Contaminated*.

Dispose of contaminated items as hazardous material according to the applicable local, national, or international health and safety regulations and pollution regulations.

---

### **WARNING!**

#### EXPLOSION HAZARD

Always lock-out tag-out the gas handling system when shutting down the detector. Unauthorized operation of the gas handling system when maintenance is being performed on the detector or its associated pipes/hoses may result in highly flammable gas being released, causing fire or explosion.

---

## **WARNING!**

### **HIGH PRESSURE GAS AND AIR**

The compressed air supply operates at a pressure that can cause injury, e.g., damage to eyes and skin punctures from debris blown by the high pressure gas or compressed air.

Always lock off or tag off the calibration gas supply and compressed air supply when shutting down the detector.

## **WARNING!**

### **EXPLOSION HAZARD**

The sample gas in the system must be vented to prevent fire or explosion during maintenance and to prevent damage to the detector during startup.

The sample gas in the pipes leading to the detector must be purged to prevent hazards to personnel during maintenance. Purge the sample gas in accordance with the safe working procedures for the site.

Allow the detector and system for returning the sample gas to run for five minutes to allow any sample gas in the system to be returned to the exhaust.

## **WARNING!**

### **HEAVY INSTRUMENT**

The detector weighs 119 kg (268 lb.) and is designed to be floor mounted. It must be moved in accordance with local safety regulations. Emerson™ recommends that a minimum of two people using suitable tools for transportation and lifting are employed.

Use suitable fasteners for the weight of the unit.

Make sure the unit is mounted on a solid, stable, and suitable floor.

Failure to follow this warning could cause an explosion or potentially hazardous situation, which if not avoided, could result in death or serious injury.

## **WARNING!**

### **ELECTRICAL SHOCK HAZARD**

Only trained, qualified personnel may install and connect power and signal cables. The installation/connection must be in accordance with all legislative requirements and applicable standards.

Only qualified personnel, familiar with the resulting potential risks, should install these instruments.

Instruments providing screw terminals for electric connections may require working near live parts.

Failure to follow this warning could cause an explosion or potentially hazardous situation, which if not avoided, could result in warranty invalidation, property damage, death, or serious injury.

## **WARNING!**

### **HIGH PRESSURE HAZARD**

The maximum compressed air pressure at the inlet valve must not exceed 10 bar (145 psi). Failure to follow this warning could cause a potentially hazardous situation, which if not avoided, could result in death or serious injury.

## **WARNING!**

### **LOOSE ITEMS**

Do not place any loose items on top of the system or inside the compartments when doors or covers are open.

Make sure that all loose items, tools, and equipment are removed from the compartments before closing doors and covers.

Failure to follow this warning could cause a potentially hazardous situation, which if not avoided, could result in death or serious injury.



## **WARNING!**

On completion of any maintenance and/or modifications, make sure:

- All tools and equipment are removed.
- No contamination (water/dust) is in the compartments.
- The detector is wiped clean.
- Vents are clear and not obstructed.
- The system is in a safe state for operation.

Failure to follow this warning could cause a potentially hazardous situation, which if not avoided, could result in death or serious injury.

## **WARNING!**

### TRANSPORTATION HAZARD

Use safety approved lifting equipment. Ensure that the equipment is tested, meets the lifting ratings for the weight of the equipment, and is in good operational condition. Failure to verify that equipment meets the lifting ratings and is in good operational condition may injure personnel or damage the detector.

## **CAUTION!**

### EQUIPMENT DAMAGE

Always follow the startup procedure. Damage to the detector may result from a failure to follow this procedure.

Failure to perform pre-system startup checks may cause damage to equipment.

## **CAUTION!**

### EQUIPMENT DAMAGE

Always follow the shutdown procedure. Damage to the detector may result from a failure to follow this procedure.

## **CAUTION!**

### EQUIPMENT DAMAGE

Ensure that the local power voltage where the unit is to be installed corresponds to the unit's nominal voltage as given on the name plate label.





## **NOTICE**

As a general principle, if any optical component other than the cell assembly, the laser modules, and the detectors is unserviceable, Emerson™ must repair the detector. This is because the repair, replacement, and alignment of the optical components requires the use of special optical test/calibration equipment and procedures. When an item is unserviceable, and no replacement procedure is given in this manual, Emerson™ must repair the fault.

**Symbols displayed on and inside the detector**

To minimize risk, labels displaying warning signs are fixed to the transmitter. You must understand their meaning, take suitable precautions, and read all instructions given in the accompanying manuals before conducting any operations.

The following table gives examples and definitions of each symbol used.

Symbol	Definition
	<p>General warning Refer to instruction manual before proceeding.</p>
	<p>Danger electricity Make sure that the system is disconnected from all electrical power supplies prior to opening doors or removing covers.</p>
	<p>Laser radiation</p>
	<p>Earth (ground) identification</p>
	<p>AC power supply</p> <hr/> <p><b>Note</b> The label shown is for illustration only. It is possible that the image will show a voltage in the range of 100 to 240 Vac.</p> <hr/>

---

# Contents

<b>Chapter 1</b>	<b>Equipment and accessories</b>	<b>1</b>
1.1	Typical installation	1
1.2	System connections	2
1.3	Typical sample head	4
1.4	Air preparation plate	5
1.5	Upper enclosure	6
<b>Chapter 2</b>	<b>Installation</b>	<b>7</b>
2.1	Installation requirements	7
2.2	Installation instructions	10
<b>Chapter 3</b>	<b>Startup</b>	<b>14</b>
<b>Chapter 4</b>	<b>Operation</b>	<b>15</b>
4.1	Leak detector manager (LDM) software	16
4.2	Data logging and reporting	19
4.3	Status lamps / errors	21
4.4	Line stop	23
4.5	PLC configuration screen	24



# 1 Equipment and accessories

## 1.1 Typical installation

Figure 1-1 shows a typical installation for a Rosemount™ CT4215 on a food handling line.

Figure 1-1: Rosemount™ CT4215 Parts

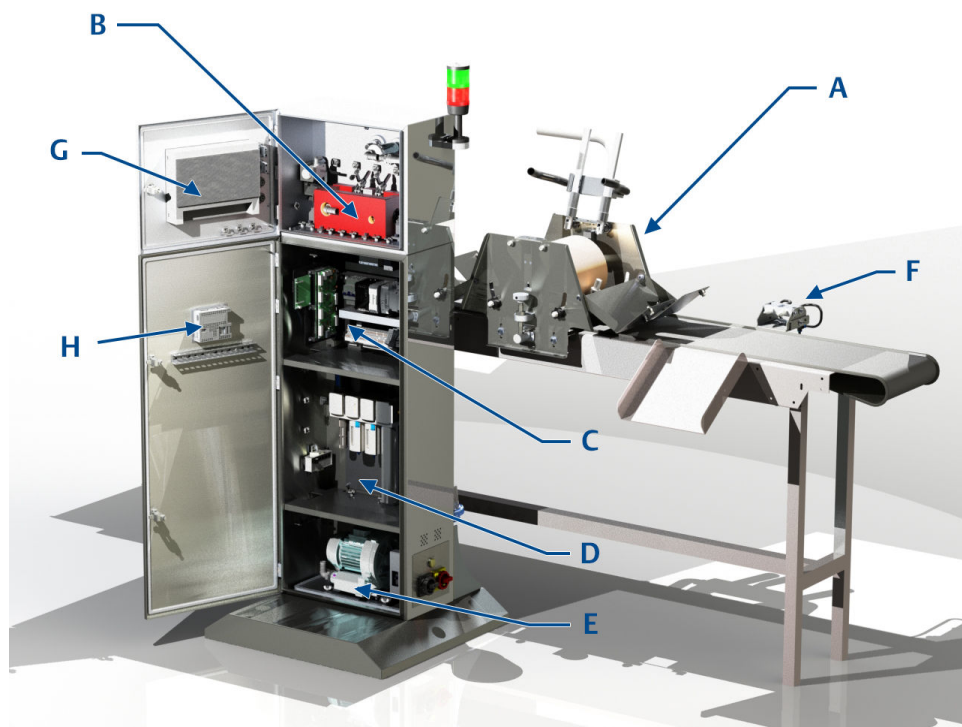

- A. *Sample head<sup>1</sup>: draws air from around the packaged product into the measurement cell.*
- B. *Analysis cell: the laser beam and sample gas pass through here for analysis.*
- C. *Electronics: laser, detector, PLC, and DC power supply.*
- D. *Air preparation: compressed air must be filtered and dried for optimum performance.*
- E. *Vacuum pump: high flow rate pump for fast sample delivery to measurement cell.*
- F. *Reject mechanism<sup>2</sup>: compressed air reject mechanism.*
- G. *Touchscreen HMI: user interface for system.*
- H. *PLC panel screen: screen set to certain PLC parameters. This will be locked to operators under normal operation.*

1. Sample head is modular and may differ depending on application.
2. May differ depending on application.

## 1.2 System connections

*Figure 1-1* shows a typical installation for a Rosemount™ CT4215 on a food handling line. *Figure 1-2* shows the external connections of the packaged leak detection system. These are located at floor level on the rear of the unit.

**Figure 1-2: External Connections**

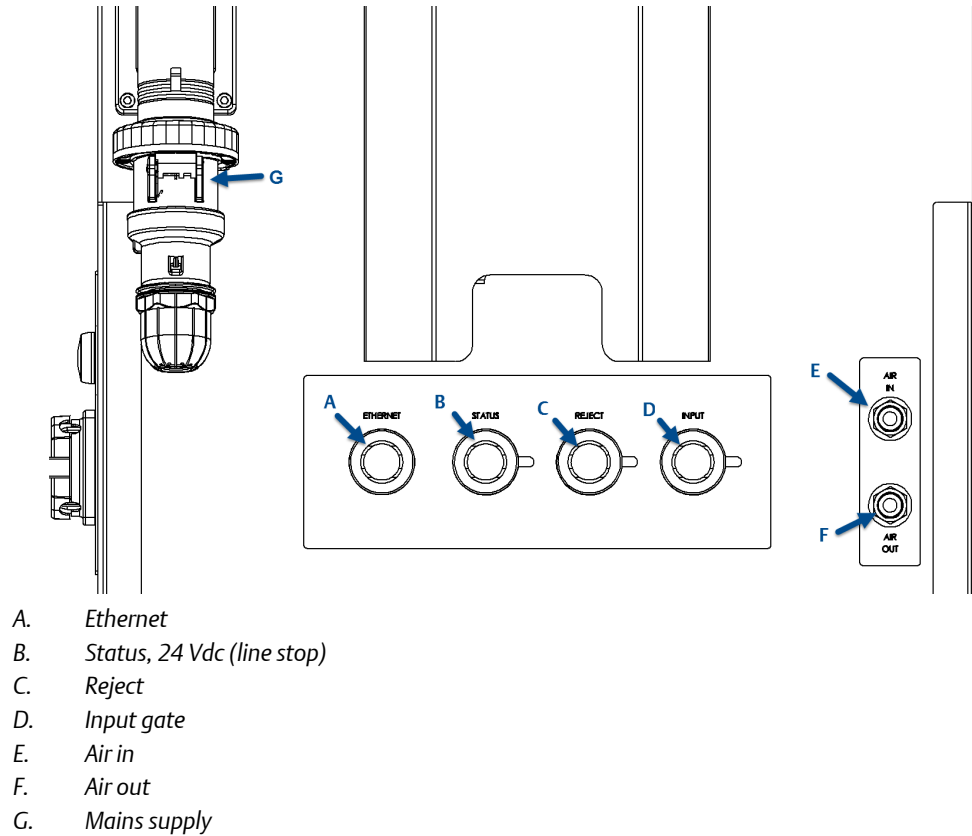

**Table 1-1: External Connections**

Letter	Designation	Type	Max rating	Description
A	Ethernet	RJ45 Ethernet	N/A	Communication with sensor
B	Status, 24 Vdc (line stop)	Bulgin 4P female	250 Vac/dc, 6 A	Customer supplied 24 V signal when line is running. Rosemount™ CT4215 health status is returned (see <a href="#">Section 4.4</a> ).
C	Reject	Bulgin 3P female	250 Vac/dc, 10 A	24 V signal to the rejection solenoid when a defective pack is detected.
D	Input gate	Bulgin 4P female	250 Vac/dc, 6 A	Gate signal to the sensor to count incoming packs.
E	Air in	8 mm push fit	10 bar (145 psi)	Customer supplied compressed air
F	Air out	8 mm push fit	6 bar (90 psi)	Regulated compressed air for accessories, i.e., rejection
G	AC supply	Mennekes right angle 2P+E	Yellow: 110 - 130 V Blue: 200 - 250 V 16A	Customer supplied mains

## 1.3 Typical sample head

The sample head is used to draw air from around the product and deliver it to the measurement cell.

To ensure a high air flow rate, the sample head is connected to the leak detector using a  $\frac{3}{4}$ -in. hose, shown in [Figure 1-3](#). There is a central roller with a sample head at either side.

---

### Note

The sample head shown is for food packaging; this may change depending on the product/production line.

---

**Figure 1-3: Sample Head (Closed)**

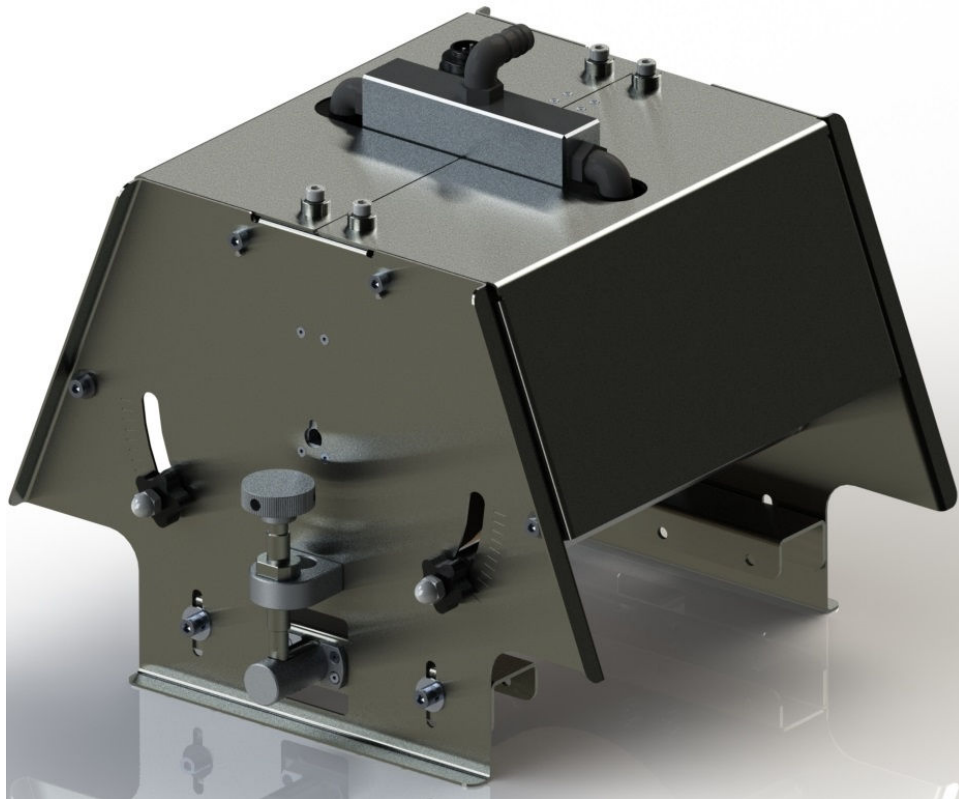

**⚠ WARNING!**

**CRUSH AND CUT HAZARD**  
Moving parts can crush and cut.

**Do not operate with the sample head open.**

**Failure to observe this warning may cause serious injury to personnel.**

---



## 1.4 Air preparation plate

The customer supplied compressed air is filtered to remove impurities and is pressure-regulated.

The assembly shown in [Figure 1-4](#) is mounted inside the leak detector control system cabinet.

**Figure 1-4: Compressed Air Preparation Plate**



- A. Shut off valve
- B. Pressure regulator with 40 µm filter
- C. 0.1 µm filter
- D. Pressure switch (MPa)
- E. Membrane dryer
- F. Solenoid switch

## 1.5 Upper enclosure

The upper enclosure is accessible with an 8 mm Allen key and comprises the following components shown in [Figure 1-5](#). The upper enclosure is the main area for maintenance access.

---

**Figure 1-5: Upper enclosure**

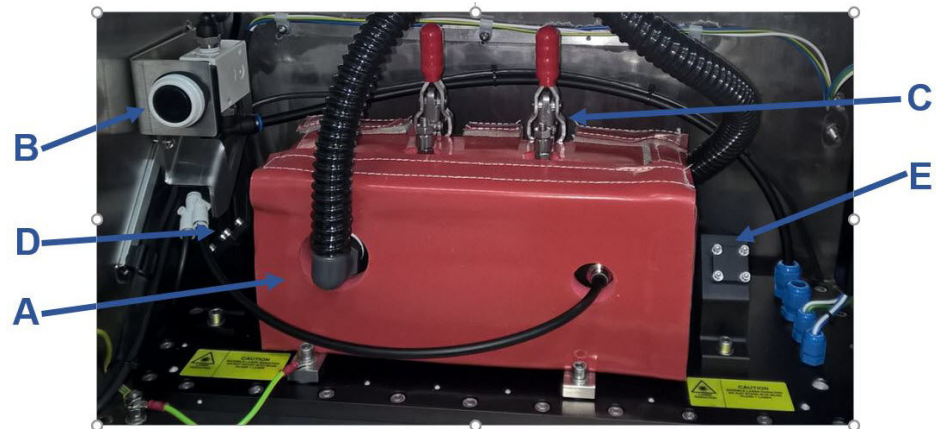

- A. *Measurement cell with insulating jacket*
  - B. *Manual purge button*
  - C. *Cell lid clamps*
  - D. *Cell input mirror, directs laser into cell*
  - E. *Cell output mirror, directs laser onto the detector*
-

## 2 Installation

### 2.1 Installation requirements

The customer provides the following:

**Table 2-1: Installation Requirements**

Customer provided	Specification
Mains supply (defined by customer)	110/120 Vac, 50 Hz
or	
Mains supply (defined by customer)	220/240 Vac, 60 Hz
Circuit breaker	16A (maximum)
Mounting	Affix to floor or building structure
Compressed air	8-10 bar / 115 - 145 psi

For the electrical power wiring, use 16 AWG stranded, three conductor copper plain or tin plated wire, rated for a minimum of 250 Vac for the required cable length. Cables must be terminated in accordance with national/local electrical standards and must be rated for operation in ambient temperatures > 176 °F (80 °C).

Emerson™ does not supply a switching system with the instrument. The customer must supply a suitably rated switch or circuit breaker to be included with this installation. Check the installation of the switch for conformity in accordance with national/local regulations and standards by inspection. The switch or circuit breaker must be suitably located, easily reached, and identified as the disconnection device for the leak detection system.

The leak detection system provides a protective earth terminal. To prevent electrical shock hazards, connect the instruments to a protective earth. Any interruption of the earth connector inside or outside the instrument or disconnecting the earth terminal may cause potential electrical shock hazard.

**Figure 2-1: Line Installation Location**

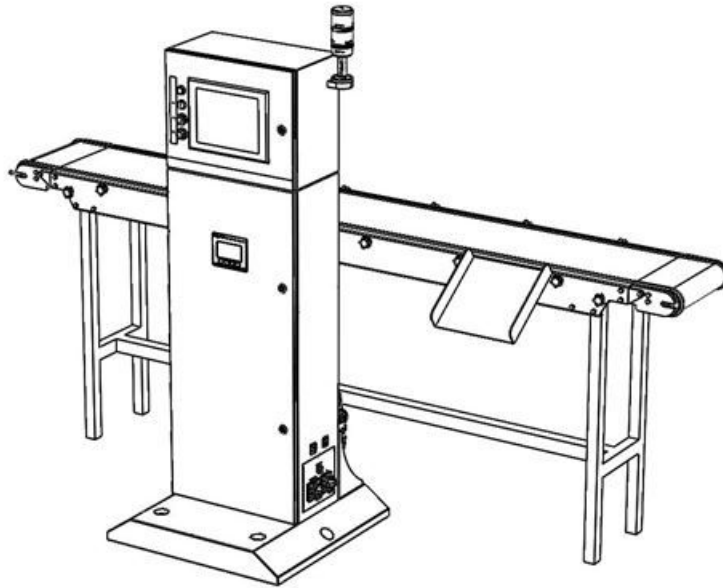

**Figure 2-2: Ground Fixing**

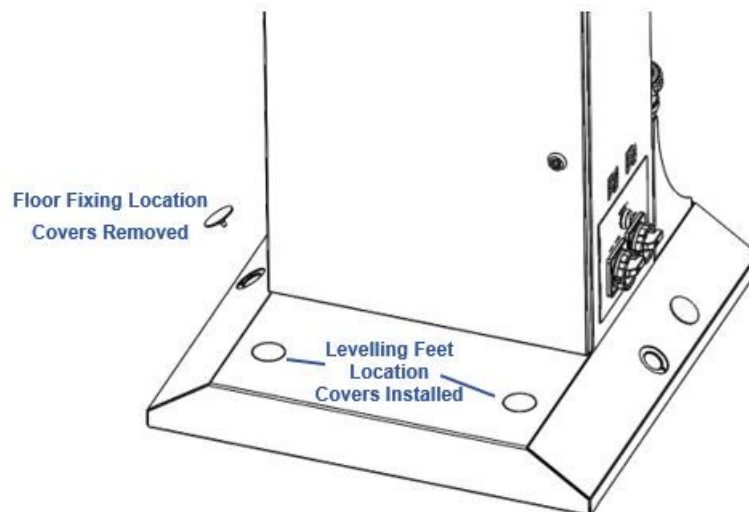

**Figure 2-3: Installation of Reject Mechanism**

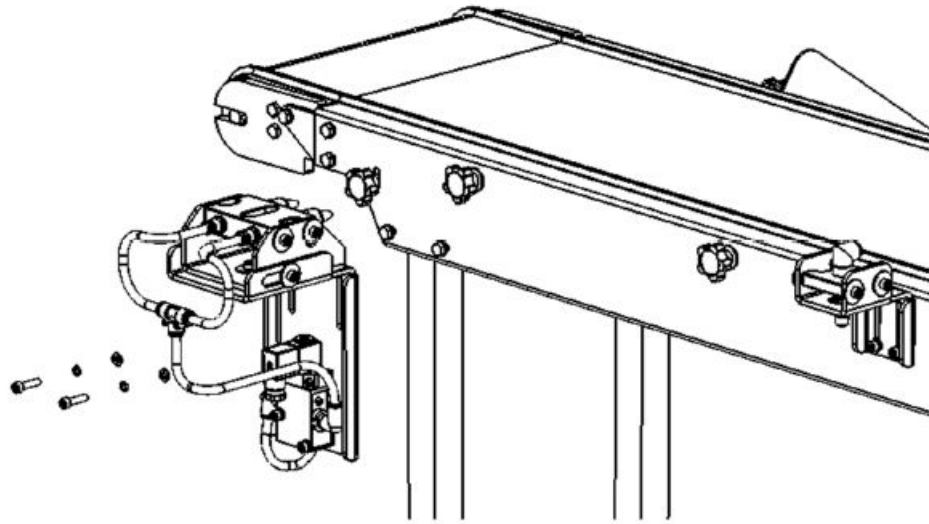

**Figure 2-4: Sample Head Installation**

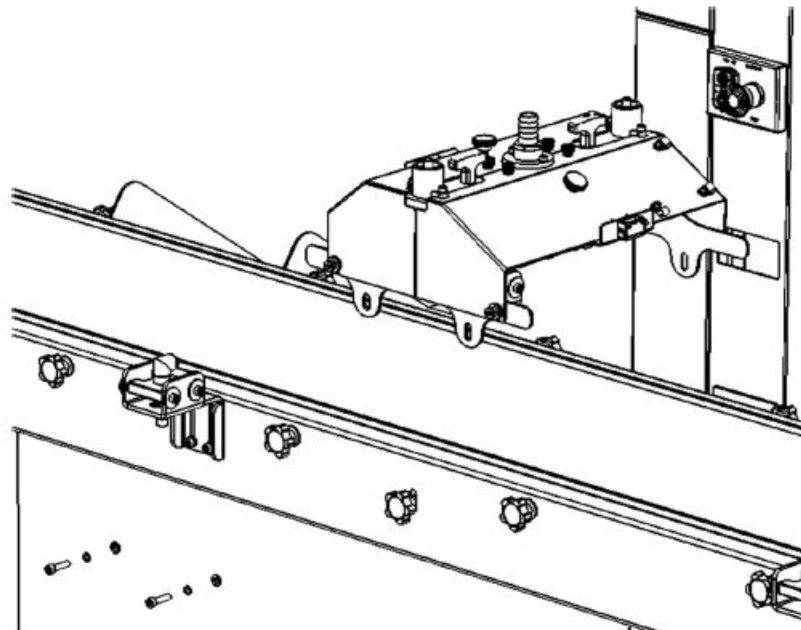

## 2.2 Installation instructions

Only Rosemount™ Customer Care Representatives should install this instrument.

### **⚠ WARNING!**

#### **LIFTING HAZARD**

The system weighs 268 lb. (119 kg). Beware of collision injury and topple injury when moving. Emerson™ recommends using a forklift to move the system.

### **⚠ WARNING!**

#### **CRUSH HAZARD**

Be careful not to crush hands and feet when moving the system.

### **⚠ WARNING!**

#### **DRILL INJURY**

Be careful to avoid injuring hands and eyes when drilling. Wear correct personal protective equipment (PPE) at all times.

### **Procedure**

1. Place the delivery crate in an open and easily accessible area, close to where the unit will be assembled and installed.
2. Remove the instrument from the crate.
  - a. Remove the fixing screws (marked in red) from the front panel of the crate and the front panel section. Place the front panel section from the crate in a safe place well away from the working area.
  - b. Release the two straps located on the unit upright section.
  - c. Carefully remove the unit from the crate.
  - d. Remove all additional parts from the crate and place them to the side of the unit.
3. Ensure that all additional parts shown are present after unloading the crate.

Required parts are shown below.

**Table 2-2: Rosemount™ CT4215 Installation Parts**

Item	Description	Quantity
A	Reject assembly	1
B	Light gate assembly	1
C	Sample head	1
D	Hardware kit	1

4. Place the unit enclosure at the desired position on the product line.

---

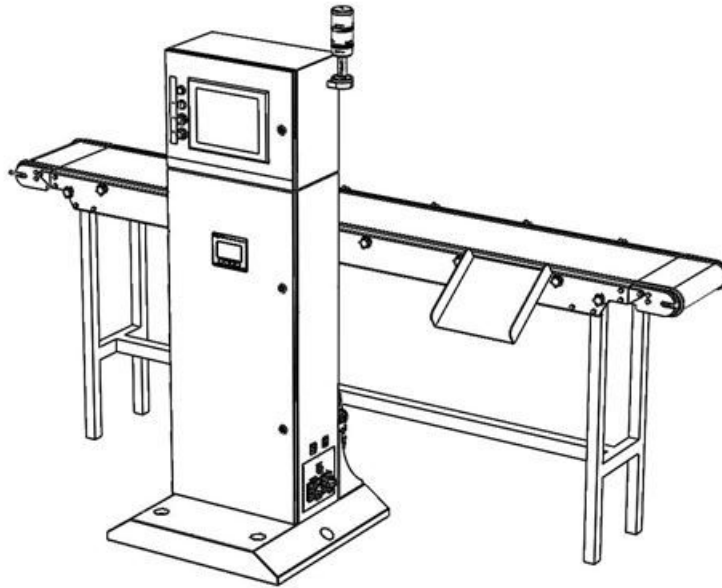
**Figure 2-5: Line Installation Location**

- 
5. Ground the instrument.
    - a. Lower the feet to the ground.
    - b. Raise the unit a few inches off the ground.
    - c. Remove the wheel brackets.
    - d. Lower the unit to the floor.
    - e. Use the feet to level of unit if required.
    - f. Bolt the unit to the floor as per site standards.

**Figure 2-6: Ground Fixing**

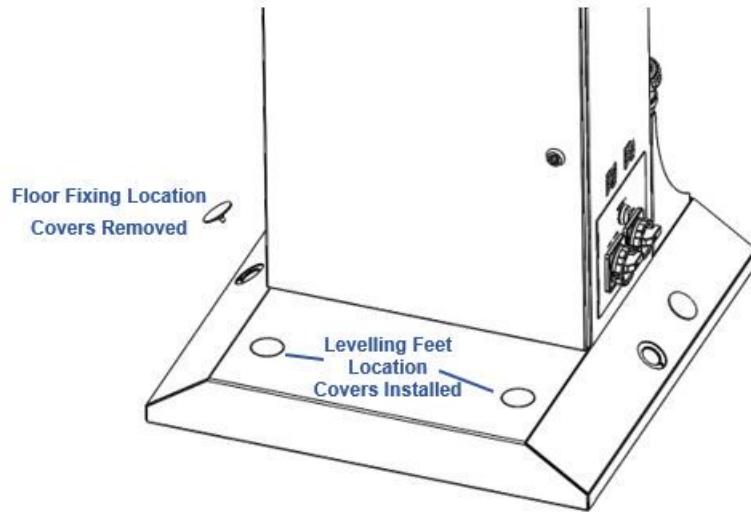

Refer to the fastener manufacturer's guide for fixing instructions and torque.

- g. Place the cap covers over the access holes.
6. Attach the light gate to the track.
- a. Drill the location hole(s) into the track side faces in the approximate positions required for input gate.  
Use track location *T* slots if available (no drilling required).
  - b. Place the light gate in the required position on the track using the fasteners supplied in the hardware kit. Hand tighten the fasteners only at this time.

**⚠ WARNING!**

**DRILL INJURY**

**Be careful to avoid injuring hands and eyes when drilling. Wear correct PPE at all times.**

- c. Adjust the angle and height of the light gate to suit the package being scanned.
- d. Secure the light gate in place using the fasteners fitted previously.
- e. Torque the fasteners to 7.6 Nm (5.6 ft.-lb.).



7. Attach the reject mechanism.

**⚠ WARNING!**

**DRILL INJURY**

**Be careful to avoid injuring hands and eyes when drilling. Wear correct PPE at all times.**

- a. Drill two location holes into the track side face in the approximate positions required for the reject mechanism.

Use track location *T* slots if available (no drilling required).

- b. Attach the reject mechanism on the track in the approximate position required using two M6 socket head cap screws, two spring washers, and two washers.
- c. Leave the reject mechanism loose by hand tightening the fasteners only.
- d. Secure the reject mechanism in place using previously fitted bolts.
- e. Torque fasteners to 5.6 ft-lb. (7.6 Nm).
- f. Adjust the angle and depth of the the reject mechanism as required. Loosen the side bolts to adjust the angle and then tighten them when aligned.

8. Attach the sample head.

**⚠ WARNING!**

**DRILL INJURY**

**Be careful to avoid injuring hands and eyes when drilling. Wear correct PPE at all times.**

- a. Drill four location holes into the track side face in the approximate position required for the sample head.

Use track location *T* slots if available (no drilling required).

- b. Place the sample head on the track in the approximate position required using four M6 socket head cap screws, two spring washers, and two washers.
- c. Leave the sample head loose by hand tightening the fasteners only.
- d. Secure the sample head in place using previously fitted fixings.
- e. Torque fasteners to 5.6 ft-lb. (7.6 Nm).
- f. Adjust the sample head height to the track as required to suit pack thickness. Loosen side bolts to adjust the height on the slots and then tighten them when aligned to the required pack height.

## 3 Startup

The Leak Detection System must be installed and fully commissioned by qualified Rosemount™ personnel prior to customer operation.

1. Turn the unit isolator switch (shown below) to the ON position.

Once power has been started, the system takes approximately two minutes to boot.

**Figure 3-1: Isolation Switches**



2. Ensure the compressed air supply is open.
3. When production begins, turn the blower isolator to the **ON** position.

### **NOTICE**

**Emerson™ recommends that the blower is switched off when the production line is not running. This will extend the lifetime of the sample air filter.**

4. Press the **Reset** button on the front of the console and ensure there is a green light on the beacon.

## 4 Operation

The packaged Leak Detection System is designed to run autonomously with minimal user interaction required. After the startup procedure in [Chapter 3](#), the system needs only a green light to run.

There are up to three components mounted onto the packaged production line. The layout of the line is shown schematically in [Figure 4-1](#).

**Figure 4-1: Schematic Layout of the System On Line**

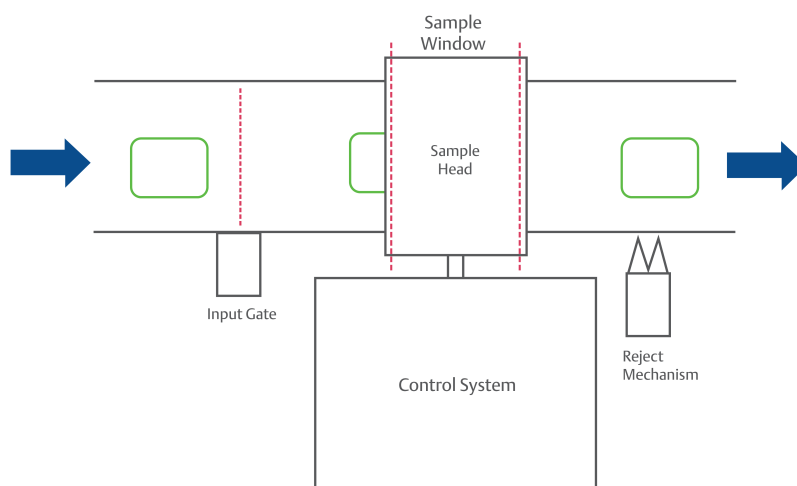

The packs flow on the schematic above from left to right. The packs pass through the input gate which is located before the sample head. A space of at least 1 in. (2.5 cm) is required between packs in order to ensure correct counting and rejection. A space of at least 6 in. (15.2 cm) is advised for best operation.

The sample head then analyzes the pack/container.

The reject mechanism safely removes faulty containers from the production line without the need to stop the line. The distances between the components is set at the time of install and is determined by the speed of the production line.

## 4.1 Leak detector manager (LDM) software

The LDM software is designed to give clear information at-a-glance.

Figure 4-2: LDM Home screen

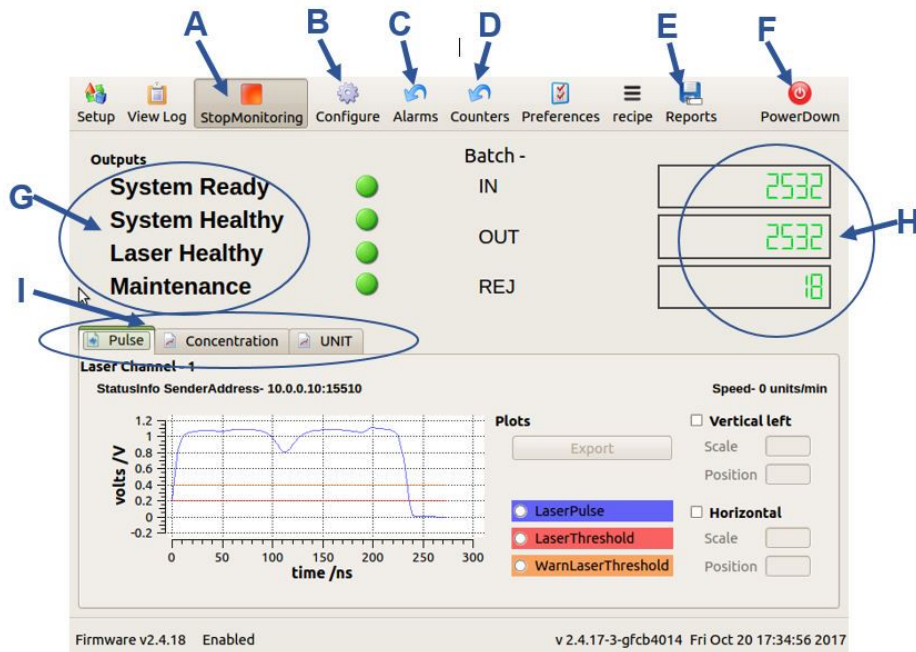

- A. **Start/Stop Monitoring:** Automatically starts monitoring during startup. Pressing the button again will pause the system and stop measuring.
- B. **Configure:** Accesses the settings and parameters of the system and is password protected.
- C. **Reset Alarms:** Clears alarms and resets status alarms to green.
- D. **Reset Counters:** Returns the counters to 0.
- E. **Reports:** Accesses the logging features of the system. Use a USB to log and export production statistics and rejection data.
- F. **Power Down:** Safely shuts down the HMI.
- G. **Outputs:** Explained in [Section 4.3](#).
- H. **Counters**
- I. **Tab selection:** Toggle between the three tabs to change which visual information is displayed.
  - A. **Pulse:** Displays the laser pulse amplitude in volts (see [Figure 4-2](#)).
  - B. **Concentration:** Displays the CO<sub>2</sub> measurement plot and shows a spike for a leaking pack (see [Figure 4-3](#)).
  - C. **UNIT:** Displays the measurement plot between the gates, refreshing for each pack (see [Figure 4-4](#)).

Figure 4-3: Concentration Tab

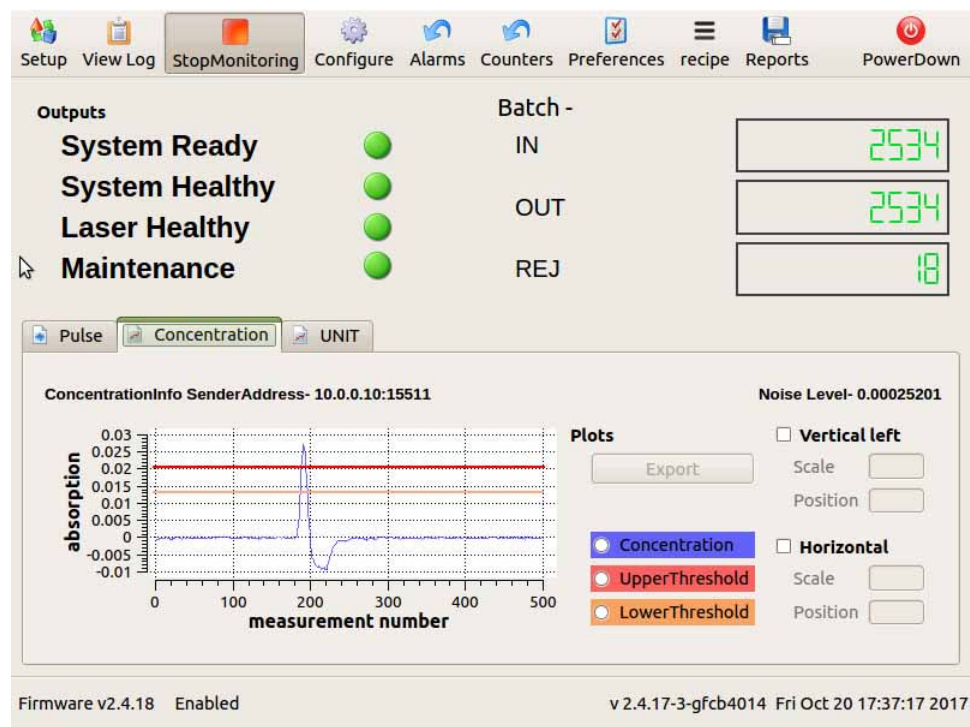

Figure 4-3 shows the *Concentration* tab with one leaking package passing through. When the blue line reaches the upper threshold (red line), the sensor sends a rejection signal to the PLC and then the rejection solenoid to remove the faulty pack from the line. The lower threshold is typically approximately 80 percent of the upper threshold and prevents the system from missing a marginal leak.

Figure 4-4: UNIT Tab

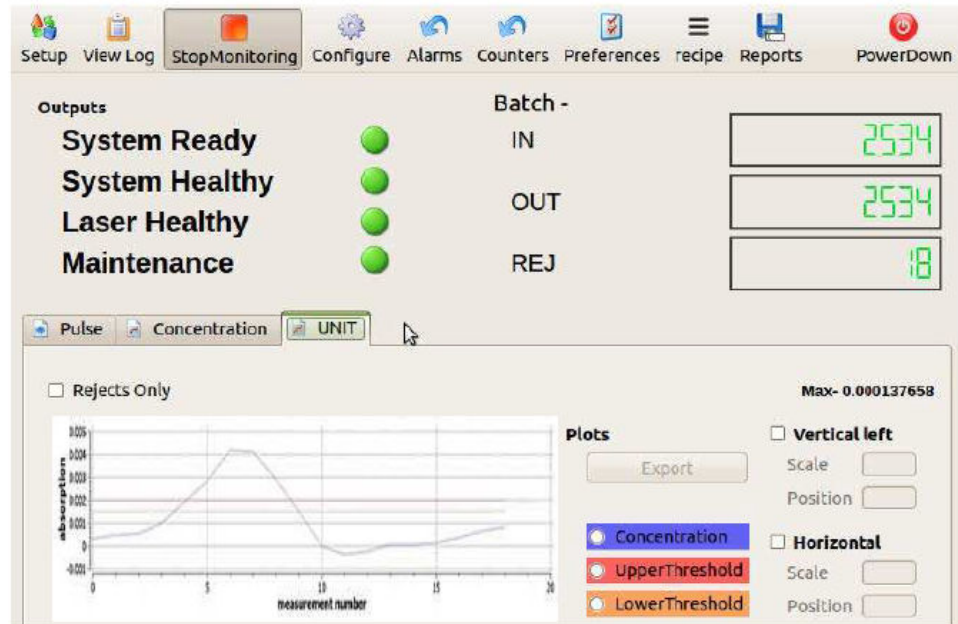

Figure 4-4 shows the UNIT tab when a leaking pack has passed through. The plot shows all data points between the input and output gate and records the size of the rejection spike.

## 4.2 Data logging and reporting

The system can store production statistics like packs processed and number of rejects. This can be transferred from the HMI on a USB stick to be analyzed elsewhere.

To enable the *Reporting* screen, click the *Reports* tab. The *Reporting* screen is password protected, and the password will be supplied or changed during installation.

**Figure 4-5: Reports Popup Window**

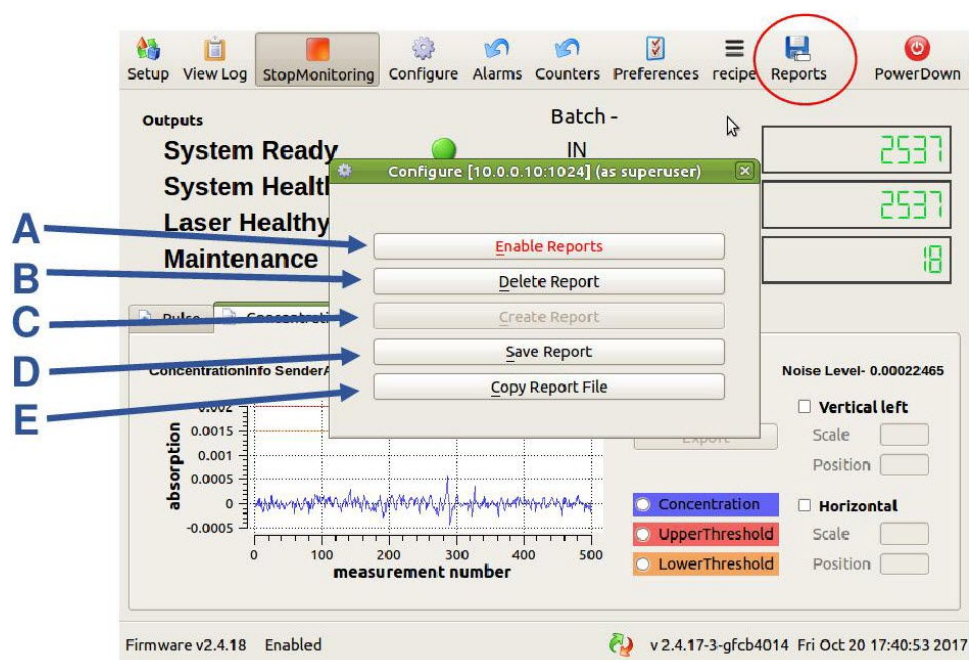

- A. **Enable/Disable Reports:** Turn reporting on or off.
- B. **Delete Report:** Delete a file from a specified location.
- C. **Create report:** Set the file name and save location.
- D. **Save Report:** Save the current file to a specified location.
- E. **Copy Report File:** Move a file from one location to another.

### Note

The file must be saved as <filename>.txt

You can export the .txt report file to a USB stick and process it elsewhere. If you open the file using Microsoft® Excel or a similar program, it will look like the example below.



**Figure 4-6: Sample Report File**

A	B	C	D	E	F	G	H
Log	file	opened	at	28.06.2017	09:10:19		
Client	name	ABC					
Product	name	Tasty ABC					
Batch	number	14					
Number	UNITS	Rejected	16				
Number	UNITS	Processed	729				
Log	file	closed	at	28.06.2017	09:39:57		
Date	Time	Leak(abs)	Leak(cal)	UT	LT	noiselevel	reject
28.06.2017	09:10:05	0.00136928	0	0.005	0.004	0.000534323	0
28.06.2017	09:10:09	0.000571722	0	0.005	0.004	0.000612099	0
28.06.2017	09:10:12	0.00140842	0	0.005	0.004	0.000612099	0
28.06.2017	09:10:14	0.000849349	0	0.005	0.004	0.000612099	0
28.06.2017	09:10:20	0.0119992	0	0.005	0.004	0.000651409	1
28.06.2017	09:10:23	0.00117535	0	0.005	0.004	0.000423098	0
28.06.2017	09:10:25	0.00119883	0	0.005	0.004	0.000423098	0
28.06.2017	09:10:27	0.0007473	0	0.005	0.004	0.000423098	0
28.06.2017	09:10:29	0.000668466	0	0.005	0.004	0.0003398	0
28.06.2017	09:10:31	0.00100697	0	0.005	0.004	0.0003398	0

- *Client/Product/Batch:* These are entered during the creation of the log file.
- *Date/Time:* The timestamp for each unit; this is set by the PC.
- *Leak (abs):* The maximum concentration value for each unit. If this value is greater than the upper threshold, this package will be rejected.
- *Leak (cal):* For certain applications, a calibration factor may be applied in order to have units for leakage (i.e., bubbles/second or mg/day).
- *UT:* The upper threshold value. If the concentration exceeds this value, the package is rejected.
- *LT:* The lower threshold: If two consecutive concentration points exceed this value, the package is rejected.
- *Noiselevel:* the noise value at the time when the package is logged.
- *Reject:* Packages which do not breach thresholds are *reject = 0*, and those which breach thresholds are *reject = 1*.

**Note**

If you want to view only rejected packages, then filter column H to show only rows with 1 in them.

**NOTICE**

The *CanInfo* type is logged for all units processed; the *Reject* type only shows the reject value.



## 4.3 Status lamps / errors

There are a number of errors that the Leak Detection System monitors, which may occur during the normal operation of the system. The errors are displayed as an illuminated lamp on the front of the enclosure. All errors latch and are cleared by the **RESET** button on the front of the enclosure. The errors are detailed below and, when activated, will trigger the red beacon bulb and line stop (if applicable).

**Figure 4-7: Cabinet Status Indicators**

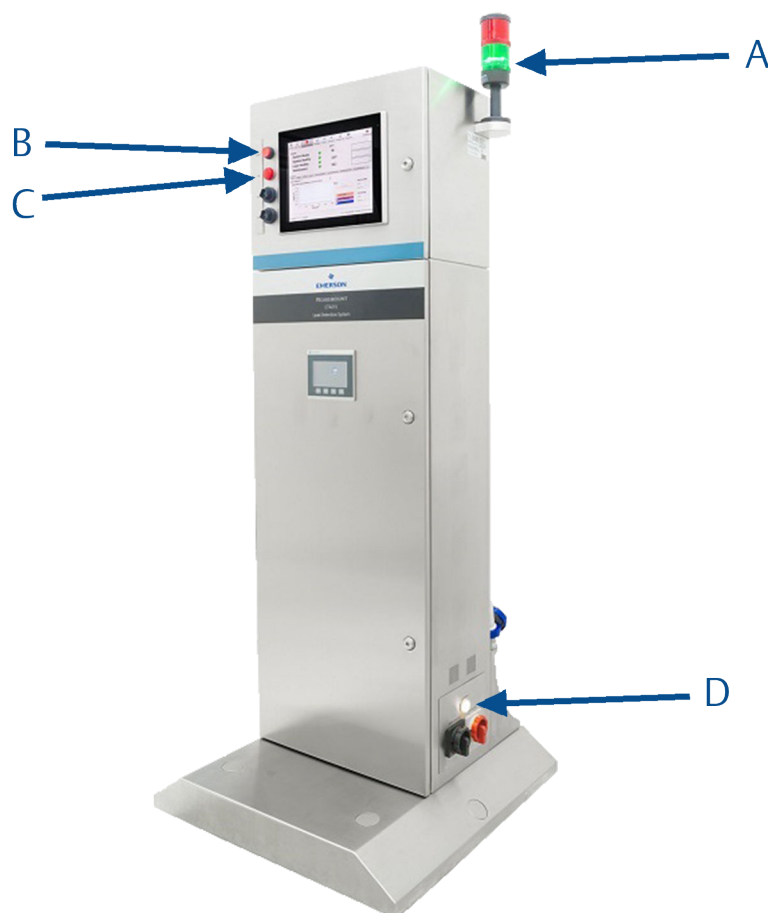

- A. *Alarm beacon: Green for healthy; red for unhealthy/line stop.*
- B. ***RESET** button to clear latched alarms.*
- C. ***AIR** status bulb. Illuminates when blower or compressed air is off.*
- D. *Blower status: A status bulb turns on when power is supplied to the blower. If the power is interrupted, the bulb doesn't turn on, and the **AIR** warning bulb turns on.*

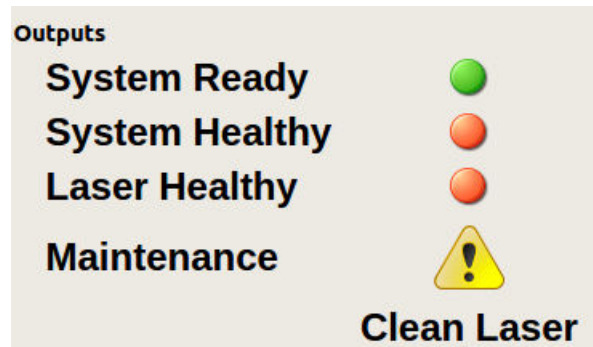
**Figure 4-8: LDM Software Errors**

1. **System Ready**: Shows when the system is ready for use. This is red during system start up.
2. **System Healthy**: The system can become unhealthy if the gate in/out count is different or if there have been  $n$  consecutive rejects (the default value is five consecutive rejects). Press **Reset counters** on the HMI to clear the error.
3. **Laser Healthy**: The laser becomes unhealthy if it is below the threshold value (see the red line in [Figure 4-2](#)). Check the beam path for obstruction or clean the cell mirrors. This error automatically clears when the pulse amplitude is above the threshold.
4. **Maintenance**: The yellow warning triangle appears if the laser pulse amplitude is below the warning threshold value. System performance is not affected, but you should consider activating the mirror purge or cleaning the cell mirrors soon. This error automatically clears when the pulse amplitude is above the warning threshold.
5. **Too many Consecutive Rejects**: If several packs are rejected in a row, this error is triggered. [Figure 4-9](#) shows the error message generated. To reset this error, press the **Reset Alarms** button on the touch screen.

**Figure 4-9: Consecutive Rejects Error**

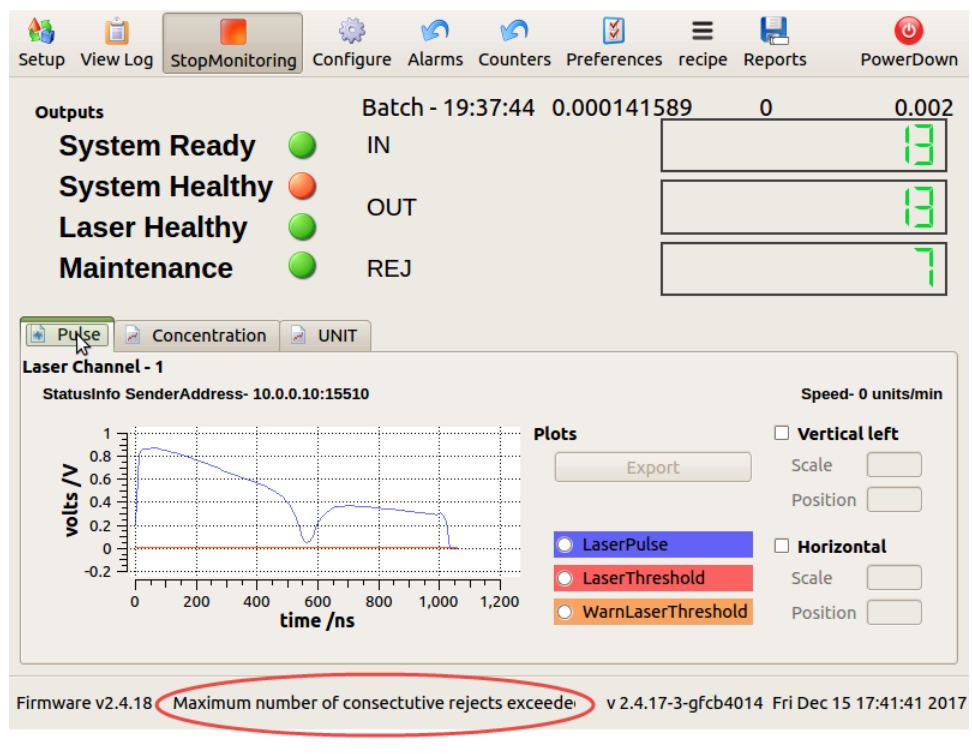

## 4.4 Line stop

The control system provides a signal that can stop the production line if there are errors on the system.

The signal is sent to the STATUS connector shown in [Figure 1-2](#). The connection is a volt-free contact and can be configured in *Normally Closed* (NC) and *Normally Open* (NO) from a customer supplied 24 V.

**Table 4-1: Line Stop Plug Pin Numbering**

	24 V line	0 V line
Normally Closed (NC)	1	2
Normally Open (NO)	3	2

The overall system is high when healthy (green light) and low when unhealthy (red light).

## 4.5 PLC configuration screen

**⚠ CAUTION!**

**EQUIPMENT DAMAGE**

The PLC settings directly control the analysis and rejection of defective containers. Only trained personnel should change the settings listed below. The PLC screen has password protection in order to prevent unauthorized access. The credentials are provided to the relevant department during installation. Following any change to line speed, pack size, or pack spacing, qualified personnel should verify the system.

The system is designed to accommodate changes in pack size and line speed. There are five configurable parameters highlighted in red below.

**Figure 4-10: PLC Configurable Parameters**

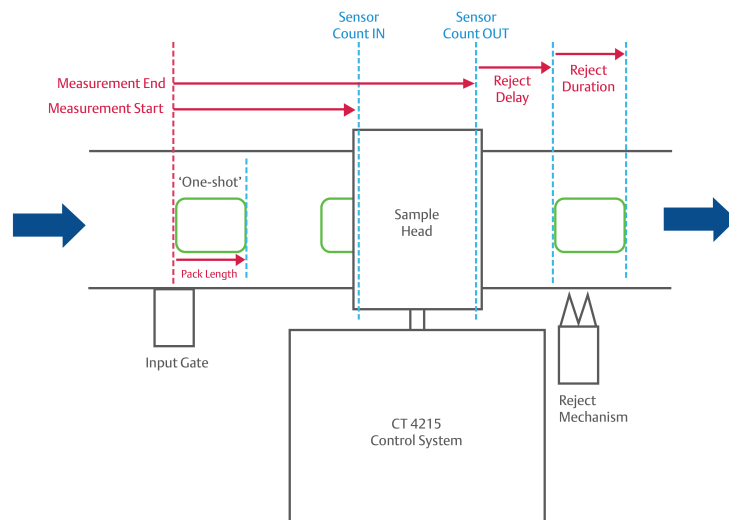

The PLC screens are shown in [Figure 4-11](#) with an explanation of each button in [Table 4-2](#).

**Figure 4-11: PLC Configuration Screens**

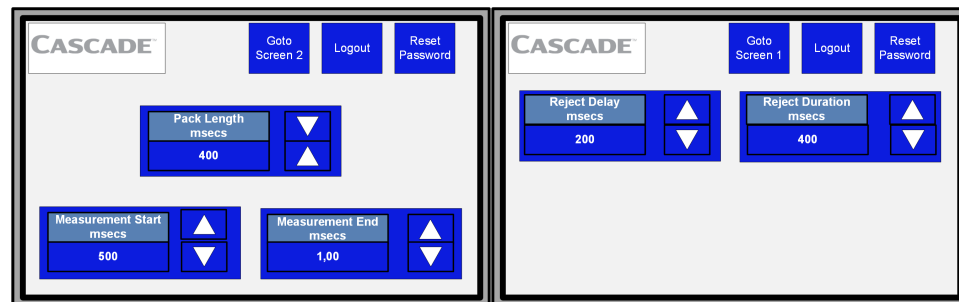

**Table 4-2: PLC Configuration Parameters**

<b>Parameter name</b>	<b>Description</b>	<b>Range</b>
Pack Length	The length of time a pack takes to pass the input gate. This timer is a de-bounce to prevent double counting of uneven packs.	0 - 2000 ms
Measurement Start	The delay between the pack passing the input gate and the sensor counting it IN and beginning analysis.	0 - 9000 ms
Measurement End	The delay between the pack being counted in and the sensor finishing analysis. This ensures complete inspection from leading edge to trailing edge. This also generates the pack OUT count on the software screen.	0 - 10000 ms
Reject Delay	The time between the bag being counted OUT and the rejection mechanism.	60000 ms (1 minute)
Reject Duration	The length of time for which the rejection solenoid is open for rejection.	10000 ms





**CASCADE TECHNOLOGIES**

Castle Business Park  
Stirling FK9 4TZ  
Scotland

📞 +44 1786 447 721  
📠 +44 1786 475 822  
✉ cascade.support@emerson.com

**GLOBAL HEADQUARTERS**

Emerson Automation Solutions  
6021 Innovation Blvd  
Shakopee, MN 55379, USA

📞 +1 800 999 9307 or +1 952 906 8888  
📠 +1 952 949 7001  
✉ cascade.support@emerson.com

**AMERICAS**

Emerson Automation Solutions  
8200 Market Blvd  
Chanhassen, MN 55317

📞 +1 800 999 9307  
📠 +1 952 949 7001  
✉ cascade.support@emerson.com

**EUROPE**

Emerson Automation Solutions  
Neuhofstrasse 19a PO Box 1046  
CH-6340 Baar  
Switzerland

📞 T +41 (0) 41 768 6111  
📠 F +41 (0) 41 768 6300  
✉ cascade.support@emerson.com

**MIDDLE EAST AND AFRICA**

Emerson Automation Solutions  
Emerson FZE  
Jebel Ali Free Zone  
Dubai, United Arab Emirates, P.O. Box 17033

📞 T +971 4 811 8100  
📠 F +971 4 886 5465  
✉ cascade.support@emerson.com

**ASIA-PACIFIC**

Emerson Automation Solutions  
1 Pandan Crescent  
Singapore 128461  
Republic of Singapore

📞 T +65 6 777 8211  
📠 F +65 6 777 0947  
✉ cascade.support@emerson.com

 [Linkedin.com/company/Emerson-Automation-Solutions](https://www.linkedin.com/company/Emerson-Automation-Solutions)

 [twitter.com/rosemount\\_news](https://twitter.com/rosemount_news)

 [Facebook.com/Rosemount](https://www.facebook.com/Rosemount)

 [youtube.com/RosemountMeasurement](https://www.youtube.com/RosemountMeasurement)

 [google.com/+RosemountMeasurement](https://plus.google.com/+RosemountMeasurement)

 [AnalyticExpert.com](https://www.analyticsexpert.com)

©2018 Emerson. All rights reserved.

The Emerson logo is a trademark and service mark of Emerson Electric Co. Rosemount is a mark of one of the Emerson family of companies. All other marks are the property of their respective owners.