

# Rosemount™ 8732EM Transmitter with Modbus Protocol Reference Manual





# Contents

<b>Chapter 1</b>	<b>Hazard messages.....</b>	<b>7</b>
	1.1 Safety messages.....	8
<b>Chapter 2</b>	<b>Introduction.....</b>	<b>11</b>
	2.1 System description.....	11
	2.2 Product recycling/disposal.....	12
<b>Chapter 3</b>	<b>Sensor Installation.....</b>	<b>13</b>
	3.1 Handling and Lifting Safety.....	13
	3.2 Location and Position.....	14
	3.3 Sensor Installation.....	17
	3.4 Process reference connection.....	26
<b>Chapter 4</b>	<b>Remote Transmitter Installation.....</b>	<b>31</b>
	4.1 Pre-installation.....	31
	4.2 Transmitter symbols.....	33
	4.3 Mounting.....	34
	4.4 Wiring.....	34
<b>Chapter 5</b>	<b>Basic configuration.....</b>	<b>47</b>
	5.1 Cover jam screw.....	47
	5.2 Basic setup.....	47
	5.3 Modbus configuration.....	50
	5.4 Local operator interface (LOI).....	51
<b>Chapter 6</b>	<b>Advanced installation details.....</b>	<b>53</b>
	6.1 Hardware switches.....	53
	6.2 Pulse output and discrete input/outputs.....	55
	6.3 Coil housing configuration.....	62
<b>Chapter 7</b>	<b>Operation.....</b>	<b>67</b>
	7.1 Introduction.....	67
	7.2 Local operator interface (LOI).....	67
<b>Chapter 8</b>	<b>Advanced Configuration Functionality.....</b>	<b>77</b>
	8.1 Introduction.....	77
	8.2 Configure outputs.....	77
	8.3 Configure LOI/Display.....	95
	8.4 Additional parameters.....	97
	8.5 Configure special units.....	99
<b>Chapter 9</b>	<b>Advanced Diagnostics Configuration.....</b>	<b>103</b>
	9.1 Introduction.....	103
	9.2 Modbus communication diagnostics.....	104
	9.3 Licensing and enabling.....	104
	9.4 Tunable empty pipe detection.....	105
	9.5 Electronics temperature.....	107

	9.6 Ground/wiring fault detection.....	107
	9.7 High process noise detection.....	108
	9.8 Coated electrode detection.....	110
	9.9 Smart Meter Verification.....	111
	9.10 Run commanded Smart Meter Verification.....	115
	9.11 Continuous Smart Meter Verification.....	117
	9.12 SMART Meter Verification test results.....	118
	9.13 Smart Meter Verification measurements.....	119
	9.14 Optimizing the Smart Meter Verification.....	121
<b>Chapter 10</b>	<b>Digital Signal Processing.....</b>	<b>123</b>
	10.1 Introduction.....	123
	10.2 Process noise profiles.....	123
	10.3 High process noise diagnostic.....	123
	10.4 Optimizing flow reading in noisy applications.....	124
	10.5 Explanation of signal processing algorithm.....	127
<b>Chapter 11</b>	<b>Maintenance.....</b>	<b>129</b>
	11.1 Introduction.....	129
	11.2 Safety information.....	129
	11.3 Installing a LOI/Display.....	129
	11.4 Replacing electronics stack.....	130
	11.5 Replacing a socket module/terminal block.....	132
	11.6 Trims.....	136
	11.7 Review.....	137
<b>Chapter 12</b>	<b>Troubleshooting.....</b>	<b>139</b>
	12.1 Introduction.....	139
	12.2 Safety information.....	139
	12.3 Installation check and guide.....	139
	12.4 Diagnostic messages.....	141
	12.5 Basic troubleshooting.....	150
	12.6 Sensor troubleshooting.....	153
	12.7 Installed sensor tests.....	156
	12.8 Uninstalled sensor tests.....	158
	12.9 Technical support and service.....	160
	12.10 Service.....	160
<b>Appendix A</b>	<b>Product specifications.....</b>	<b>161</b>
	A.1 Rosemount 8700M Flowmeter Platform specifications .....	161
	A.2 Transmitter specifications.....	165
	A.3 8705-M Flanged Sensor Specifications.....	174
	A.4 8711-M/L Wafer Sensor Specifications.....	179
	A.5 8721 Hygienic (Sanitary) Sensor Specifications.....	181
<b>Appendix B</b>	<b>Product certifications.....</b>	<b>185</b>
<b>Appendix C</b>	<b>Modbus Coil and Register Map.....</b>	<b>187</b>
<b>Appendix D</b>	<b>Wiring Diagrams.....</b>	<b>201</b>
	D.1 Wiring sensor to transmitter.....	201

<b>Appendix E</b>	<b>Implementing a Universal Transmitter.....</b>	<b>203</b>
	E.1 Safety messages.....	203
	E.2 Universal capability.....	203
	E.3 Three step process.....	203
	E.4 Wiring the universal transmitter.....	204
	E.5 Rosemount sensors.....	204
	E.6 Brooks sensors.....	208
	E.7 Endress and Hauser sensors.....	209
	E.8 Fischer and Porter sensors.....	210
	E.9 Foxboro sensors.....	216
	E.10 Kent Veriflux VTC sensor.....	220
	E.11 Kent sensors.....	221
	E.12 Krohne sensors.....	222
	E.13 Taylor sensors.....	223
	E.14 Yamatake Honeywell sensors.....	225
	E.15 Yokogawa sensors.....	226
	E.16 Generic manufacturer sensor to 8732 Transmitter.....	227



# 1 Hazard messages

This document uses the following criteria for hazard messages based on ANSI standards Z535.6-2011 (R2017).

## **⚠ DANGER**

Serious injury or death will occur if a hazardous situation is not avoided.

## **⚠ WARNING**

Serious injury or death could occur if a hazardous situation is not avoided.

## **⚠ CAUTION**

Minor or moderate injury will or could occur if a hazardous situation is not avoided.

## **NOTICE**

Data loss, property damage, hardware damage, or software damage can occur if a situation is not avoided. There is no credible risk of physical injury.

### **Physical access**

## **⚠ WARNING**

Unauthorized personnel can potentially cause significant damage and/or misconfiguration of end users' equipment. Protect against all intentional or unintentional unauthorized use. Physical security is an important part of any security program and fundamental to protecting your system. Restrict physical access to protect users' assets. This is true for all systems used within the facility.

## 1.1 Safety messages

### **⚠ WARNING**

#### **General hazards**

Failure to follow these instructions could result in death or serious injury.

Read this manual before working with the product. For personal and system safety, and for optimum product performance, make sure you thoroughly understand the contents before installing, using, or maintaining this product.

Installation and servicing instructions are for use by qualified personnel only. Do not perform any servicing other than that contained in the operating instructions, unless qualified.

Verify the installation is completed safely and is consistent with the operating environment.

Do not substitute factory components with non-factory components. Substitution of components may impair Intrinsic Safety.

Do not perform any services other than those contained in this manual.

Process leaks may result in death or serious injury.

Mishandling products exposed to a hazardous substance may result in death or serious injury.

The electrode compartment may contain line pressure; it must be depressurized before the cover is removed.

If the product being returned was exposed to a hazardous substance as defined by OSHA, a copy of the required Safety Data Sheet (SDS) for each hazardous substance identified must be included with the returned goods.

The products described in this document are NOT designed for nuclear-qualified applications. Using non-nuclear qualified products in applications that require nuclear-qualified hardware or products may cause inaccurate readings. For information on Emerson nuclear-qualified products, contact your local sales representative.

---



## **⚠ WARNING**

### **Explosion hazards**

Failure to follow these instructions could cause an explosion, resulting in death or serious injury.

If installed in explosive atmospheres (hazardous areas, classified areas, or an “Ex” environment), it must be assured that the device certification and installation techniques are suitable for that particular environment.

Do not remove transmitter covers in explosive atmospheres when the circuit is live. Both transmitter covers must be fully engaged to meet explosion-proof requirements.

Do not disconnect equipment when a flammable or combustible atmosphere is present.

Before connecting a HART-based communicator in an explosive atmosphere, make sure the instruments in the loop are installed in accordance with intrinsically safe or nonincendive field wiring practices.

Do not connect a Rosemount transmitter to a non-Rosemount sensor that is located in an explosive atmosphere. The transmitter has not been evaluated for use with other manufacturers' magnetic flowmeter sensors in hazardous (Ex or Classified) areas. Special care should be taken by the end-user and installer to ensure the transmitter meets the safety and performance requirements of the other manufacturer's equipment.

Follow national, local, and plant standards to properly earth ground the transmitter and sensor. The earth ground must be separate from the process reference ground.

Flow meters ordered with non-standard paint options or non-metallic labels may be subject to electrostatic discharge. To avoid electrostatic charge build-up, do not rub the flow meter with a dry cloth or clean with solvents.

## **⚠ WARNING**

### **Electrical hazards**

Failure to follow these instructions could cause damaging and unsafe discharge of electricity, resulting in death or serious injury.

Follow national, local, and plant standards to properly earth ground the transmitter and sensor. The earth ground must be separate from the process reference ground.

Disconnect power before servicing circuits.

Allow ten minutes for charge to dissipate prior to removing electronics compartment cover. The electronics may store energy in this period immediately after power is removed.

Avoid contact with leads and terminals. High voltage that may be present on leads could cause electrical shock.

Flow meters ordered with non-standard paint options or non-metallic labels may be subject to electrostatic discharge. To avoid electrostatic charge build-up, do not rub the flow meter with a dry cloth or clean with solvents.

## NOTICE

### Damage hazards

Failure to follow these instructions could result in damage or destruction of equipment.

The sensor liner is vulnerable to handling damage. Never place anything through the sensor for the purpose of lifting or gaining leverage. Liner damage may render the sensor inoperable.

Metallic or spiral-wound gaskets should not be used as they will damage the liner face of the sensor. If spiral wound or metallic gaskets are required for the application, lining protectors must be used. If frequent removal is anticipated, take precautions to protect the liner ends. Short spool pieces attached to the sensor ends are often used for protection.

Correct flange bolt tightening is crucial for proper sensor operation and life. All bolts must be tightened in the proper sequence to the stated torque specifications. Failure to observe these instructions could result in severe damage to the sensor lining and possible sensor replacement.

In cases where high voltage/high current are present near the meter installation, ensure proper protection methods are followed to prevent stray electricity from passing through the meter. Failure to adequately protect the meter could result in damage to the transmitter and lead to meter failure.

Completely remove all electrical connections from both sensor and transmitter prior to welding on the pipe. For maximum protection of the sensor, consider removing it from the pipeline.

Do not connect mains or line power to the magnetic flow tube sensor or to the transmitter coil excitation circuit.

---

## 2 Introduction

### 2.1 System description

The flowmeter consists of a sensor and a transmitter. The sensor is installed in-line with the process piping; the transmitter can be integrally mounted to the sensor or remotely mounted away from the sensor.

**Figure 2-1: Integral field mount transmitter**



**Figure 2-2: Remote field mount transmitter**



There are three Rosemount flow sensors available.

**Figure 2-3: 8705 Flanged sensor**



---

**Figure 2-4: 8711 Wafer sensor**



---

**Figure 2-5: 8721 Hygienic sensor**



---

The flow sensor contains two magnetic coils located on opposite sides of the sensor. Two electrodes, located perpendicular to the coils and opposite each other, make contact with the liquid. The transmitter energizes the coils and creates a magnetic field. A conductive liquid moving through the magnetic field generates an induced voltage at the electrodes. This voltage is proportional to the flow velocity. The transmitter converts the voltage detected by the electrodes into a flow reading. A cross-sectional view is shown in [Figure 2-6](#).

---

**Figure 2-6: (8705) Sensor cross section**

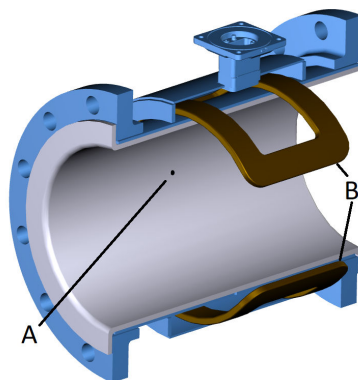

- A. Electrode
- B. Coils

---

## 2.2 Product recycling/disposal

Recycling of equipment and packaging should be taken into consideration and disposed of in accordance with local and national legislation/regulations.

## 3 Sensor Installation

This chapter provides instructions for handling and installing the flow sensor with or without an integrally mounted transmitter.

### Related information

[Remote Transmitter Installation](#)

### 3.1 Handling and Lifting Safety

#### **⚠ CAUTION**

To reduce the risk of personal injury or damage to equipment, follow all lifting and handling instructions.

- Handle all parts carefully to prevent damage. Whenever possible, transport the system to the installation site in the original shipping container.
- PTFE-lined sensors are shipped with end covers that protect flange sealing surfaces from both mechanical damage and normal unrestrained distortion. Remove the end covers just before installation.
- Keep the shipping plugs in the conduit ports until you are ready to connect and seal them. Appropriate care should be taken to prevent water ingress.
- The sensor should be supported by the pipeline. Pipe supports are recommended on both the inlet and outlet sides of the sensor pipeline. There should be no additional support attached to the sensor.
- Use proper PPE (Personal Protection Equipment) including safety glasses and safety shoes.
- Do not lift the meter by holding the electronics housing or junction box.
- The sensor liner is vulnerable to handling damage. Never place anything through the sensor for the purpose of lifting or gaining leverage. Liner damage can render the sensor useless.
- Do not drop the device from any height.

### 3.1.1 Lifting lugs

#### ⚠ CAUTION

If provided, use the lifting lugs on each flange to handle the flow meter when it is transported and lowered into place at the installation site. If lifting lugs are not provided, the flow meter must be supported with a lifting sling on each side of the housing.

- Standard pressure 3 inch through 36 inch flanged magnetic flow meters come with lifting lugs.
- High pressure (above 600#) 1 inch through 24 inch flanged magnetic flow meters come with lifting lugs.
- Wafers and sanitary magnetic flow meters do not come with lifting lugs.

**Figure 3-1: Example lifting without and with lifting lugs**

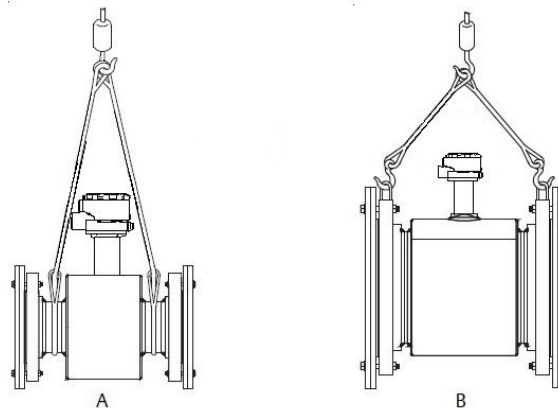

A. Without lifting lugs

B. With lifting lugs

## 3.2 Location and Position

### 3.2.1 Environmental considerations

To ensure maximum transmitter life, avoid extreme temperatures and excessive vibration. Typical problem areas include the following:

- High-vibration lines with integrally mounted transmitters
- Tropical/desert installations in direct sunlight
- Outdoor installations in arctic climates

### 3.2.2 Upstream and downstream piping

To ensure specified accuracy over widely varying process conditions, it is recommended to install the sensor with a minimum of five straight pipe diameters upstream and two pipe diameters downstream from the electrode plane.

**Figure 3-2: Upstream and downstream straight pipe diameters**

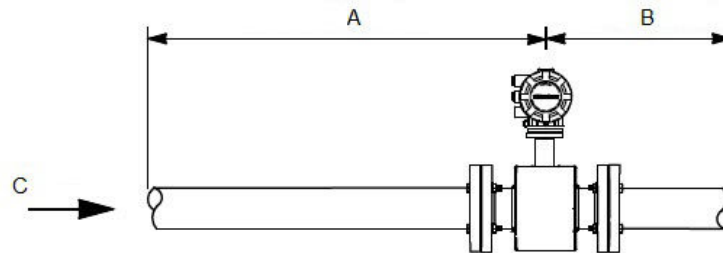

- A. Five pipe diameters (upstream)
- B. Two pipe diameters (downstream)
- C. Flow direction

Installations with reduced upstream and downstream straight runs are possible. In reduced straight run installations, the meter may not meet accuracy specifications. Reported flow rates will still be highly repeatable.

### 3.2.3 Flow direction

The sensor should be mounted so that the arrow points in the direction of flow.

**Figure 3-3: Flow direction arrow**



### 3.2.4 Sensor piping location and orientation

The sensor should be installed in a location that ensures it remains full during operation. Depending on where it is installed, orientation must also be considered.

- Vertical installation with upward process fluid flow keeps the cross-sectional area full, regardless of flow rate.
- Horizontal installation should be restricted to low piping sections that are normally full.

Figure 3-4: Sensor orientation

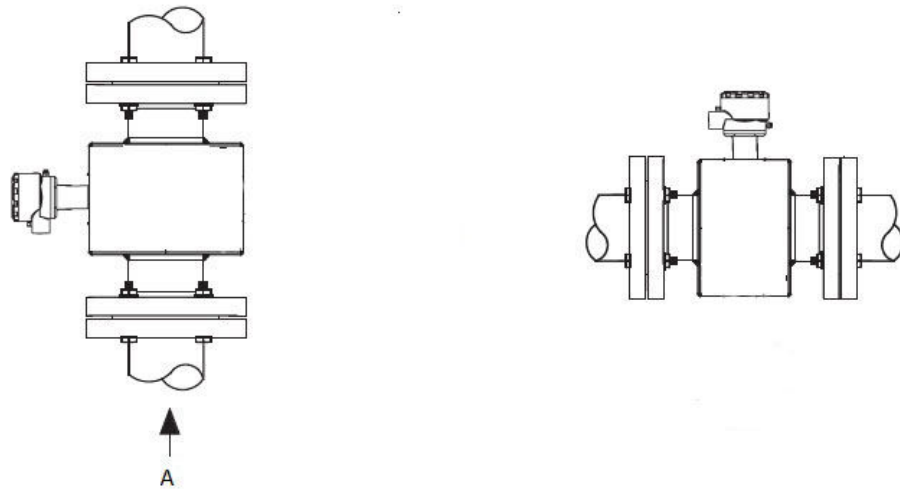

A. Flow direction

### 3.2.5 Transmitter or remote junction box rotation

To rotate housing, disconnect the interconnecting cables from the electronics board inside the transmitter housing prior to rotation.

### 3.2.6 Electrode orientation

The electrodes in the sensor are properly oriented when the two measurement electrodes are in the 3 and 9 o'clock positions or within 45 degrees from the horizontal, as shown on the left side of [Figure 3-5](#). Avoid any mounting orientation that positions the top of the sensor at 90 degrees from the vertical position as shown on the right of [Figure 3-5](#).



Figure 3-5: Electrode orientation

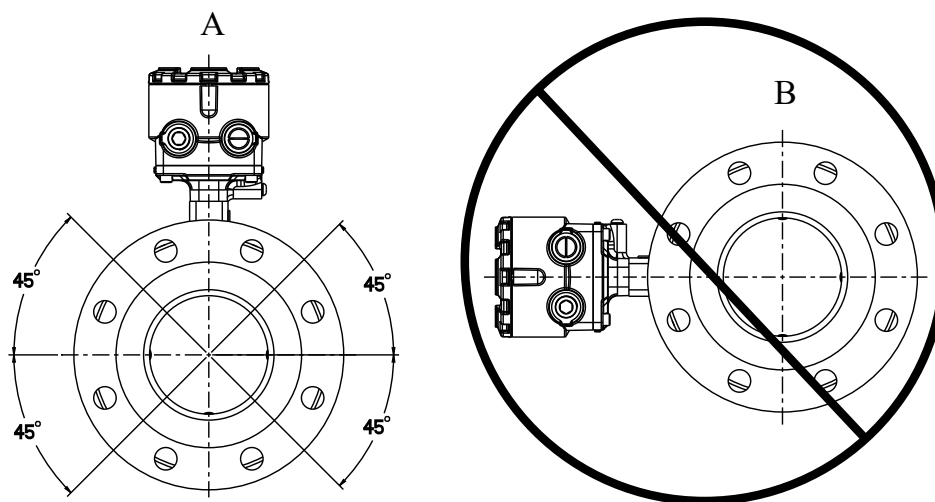

- A. Correct orientation
- B. Incorrect orientation

The sensor may require a specific orientation to comply with Hazardous Area T-code rating. Refer to the appropriate reference manual for any potential restrictions.

## 3.3 Sensor Installation

### 3.3.1 Flanged sensors

#### Gaskets

- It is the responsibility of the customer to provide an appropriate gasket for their installation.
- The gasket material must be compatible with the process fluid and process conditions. See note below for more information regarding suitable gasket materials.
- If no ground rings or lining protectors are being used, a gasket is required at each process connection. See [Figure 3-6](#).
- If using grounding ring(s), a gasket is required on each side of each grounding ring. See [Figure 3-7](#).
- If using lining protectors, a gasket is required between each lining protector and each process connection. See [Figure 3-8](#) and [Figure 3-9](#).

#### Note

- Metallic or spiral wound gaskets should not be used in contact with the liner face. **They will damage the liner face.** If metallic or spiral wound gaskets are required for the application, then lining protectors must be used.
- Examples of non-metallic gasket materials that will not damage the liner face are rubber, fiber, or PTFE.
- Flat ring gasket types are suitable for raised-face (RF) flanges. Full-face gasket types are suitable for flat-face (FF) flanges. Full-face gaskets may be used with raised-face flanges.

**Figure 3-6: Flanged Gasket Placement with no Grounding Ring(s) or Lining Protector(s)**

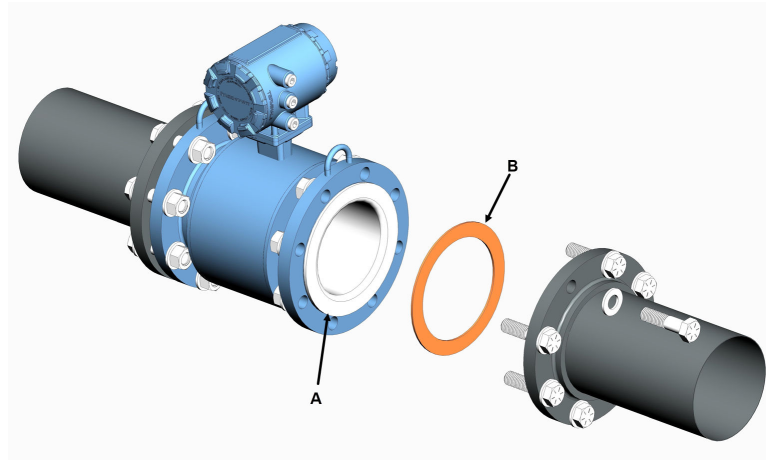

- A. Liner face
- B. Customer supplied gasket (x2)

**Figure 3-7: Flanged Gasket Placement with Grounding Ring(s)**

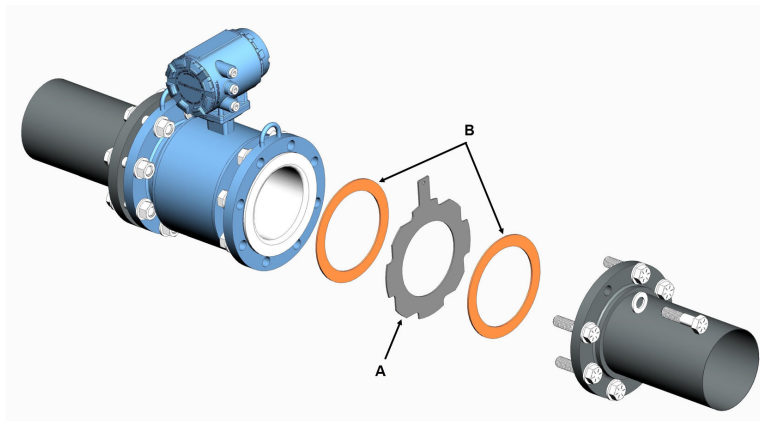

- A. Ground ring
- B. Customer supplied gaskets (x2 per ground ring)

**Figure 3-8: Flanged Gasket Placement with Stamped Lining Protector(s)**

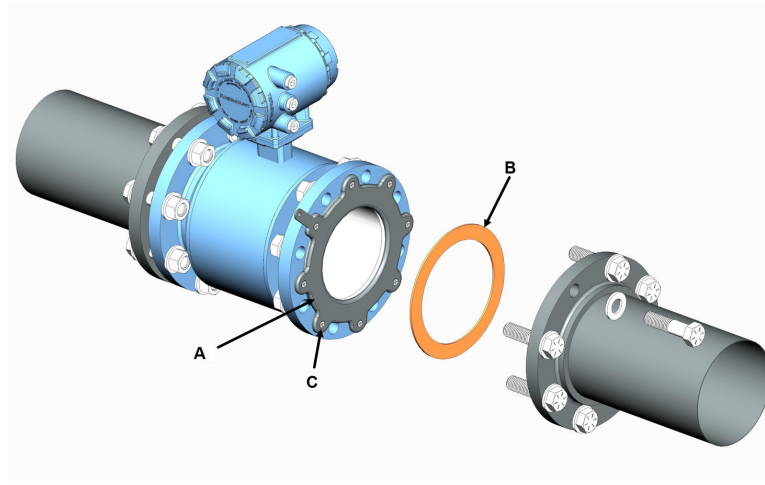

- A. Stamped lining protector
- B. Customer supplied gasket (x1 per lining protector)
- C. Lining protector fastening screws — **DO NOT REMOVE** the screws or the lining protector.

**Figure 3-9: Flanged Gasket Placement with Machined Stamped Lining Protector(s)**

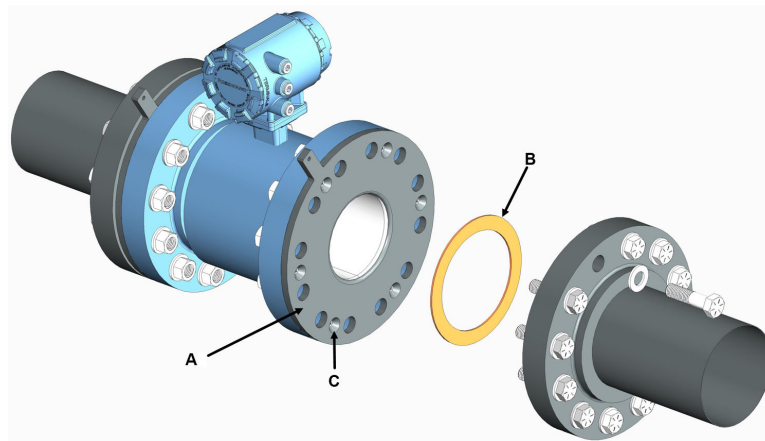

- A. Machined lining protector
- B. Customer supplied gasket (x1 per lining protector)
- C. Lining protector fastening screws — **DO NOT REMOVE** the screws or the lining protector.

### Bolts

#### Note

Do not bolt one side at a time. Tighten both sides simultaneously. Example:

1. Snug upstream
2. Snug downstream
3. Tighten upstream (20%)
4. Tighten downstream (20%)

Do not snug and tighten the upstream side and then snug and tighten the downstream side. Failure to alternate between the upstream and downstream flanges when tightening bolts may result in liner damage.

Suggested torque values by sensor line size and liner type are listed in [Table 3-2](#) for ASME B16.5 flanges and [Table 3-3](#) or [Table 3-4](#) for EN flanges. Consult the factory if the flange rating of the sensor is not listed. Tighten flange bolts on the upstream side of the sensor in the incremental sequence shown in [Figure 3-10](#) to 20% of the suggested torque values. Repeat the process on the downstream side of the sensor. For sensors with greater or fewer flange bolts, tighten the bolts in a similar crosswise sequence. Repeat this entire tightening sequence at 40%, 60%, 80%, and 100% of the suggested torque values.

If leakage occurs at the suggested torque values, the bolts can be tightened in additional 10% increments until the joint stops leaking, or until the measured torque value reaches the maximum torque value of the bolts. Practical consideration for the integrity of the liner often leads to distinct torque values to stop leakage due to the unique combinations of flanges, bolts, gaskets, and sensor liner material.

Check for leaks at the flanges after tightening the bolts. Failure to use the correct tightening methods can result in severe damage. While under pressure, sensor materials may deform over time and require a second tightening 24 hours after the initial installation.

**Figure 3-10: Flange bolt torquing sequence**

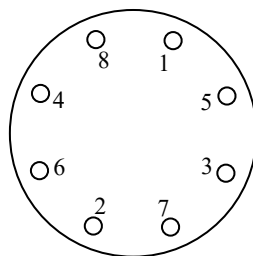

Prior to installation, identify the lining material of the flow sensor to ensure the suggested torque values are applied.

**Table 3-1: Lining material**

Fluoropolymer liners	Other liners
T - PTFE	P - Polyurethane
F - ETFE	N - Neoprene
A - PFA	L - Linatex (Natural Rubber)
K - PFA+	D - Adiprene

**Table 3-2: Suggested flange bolt torque values for Rosemount 8705 (ASME) sensors**

Size code	Line size	Fluoropolymer liners		Other liners	
		Class 150 (pound-feet)	Class 300 (pound-feet)	Class 150 (pound-feet)	Class 300 (pound-feet)
005	0.5 inch (15 mm)	4	8	N/A	N / A
010	1 inch (25 mm)	8	19	6	20
015	1.5 inch (40 mm)	17	36	13	38
020	2 inch (50 mm)	34	20	26	21
025	2.5 inch (65 mm)	40	30	30	31
030	3 inch (80 mm)	58	37	44	39
040	4 inch (100 mm)	41	50	31	52
050	5 inch (125 mm)	61	61	46	62
060	6 inch (150 mm)	77	51	59	50
080	8 inch (200 mm)	105	81	79	77
100	10 inch (250 mm)	98	84	74	81
120	12 inch (300 mm)	131	126	99	110
140	14 inch (350 mm)	162	110	123	98
160	16 inch (400 mm)	154	154	117	123
180	18 inch (450 mm)	236	175	179	133
200	20 inch (500 mm)	207	191	157	145
240	24 inch (600 mm)	293	293	222	222
300	30 inch (750 mm)	309	432	234	328
360	36 inch (900 mm)	442	589	335	447

**Table 3-3: Suggested flange bolt torque values for Rosemount 8705 sensors with fluoropolymer liners (EN 1092-1)**

Size code	Line size	Fluoropolymer liners (in Newton-meters)			
		PN 10	PN 16	PN 25	PN 40
005	0.5 inch (15 mm)	N/A	N/A	N/A	10
010	1 inch (25 mm)	N/A	N/A	N/A	23
015	1.5 inch (40 mm)	N/A	N/A	N/A	49
020	2 inch (50 mm)	N/A	62	N/A	62
025	2.5 inch (65 mm)	N/A	43	N/A	43
030	3 inch (80 mm)	N/A	51	N/A	51
040	4 inch (100 mm)	N/A	53	76	76
050	5.0 inch (125 mm)	N/A	70	N/A	106
060	6 inch (150mm)	N/A	95	132	132

**Table 3-3: Suggested flange bolt torque values for Rosemount 8705 sensors with fluoropolymer liners (EN 1092-1) (continued)**

Size code	Line size	Fluoropolymer liners (in Newton-meters)			
		PN 10	PN 16	PN 25	PN 40
080	8 inch (200 mm)	135	90	134	180
100	10 inch (250 mm)	103	123	200	265
120	12 inch (300 mm)	118	170	205	285
140	14 inch (350 mm)	166	223	344	450
160	16 inch (400 mm)	227	298	445	662
180	18 inch (450 mm)	198	299	391	452
200	20 inch (500 mm)	225	408	474	558
240	24 inch (600 mm)	300	601	625	903

**Table 3-4: Suggested flange bolt torque values for Rosemount 8705 sensors with non-fluoropolymer liners (EN 1092-1)**

Size code	Line size	Non-fluoropolymer liners (in Newton-meters)			
		PN 10	PN 16	PN 25	PN 40
005	0.5 inch (15 mm)	N/A	N/A	N/A	8
010	1 inch (25 mm)	N/A	N/A	N/A	18
015	1.5 inch (40 mm)	N/A	N/A	N/A	37
020	2 inch (50 mm)	N/A	47	N/A	47
025	2.5 inch (65 mm)	N/A	33	N/A	33
030	3 inch (80 mm)	N/A	38	N/A	38
040	4 inch (100 mm)	N/A	41	57	57
050	5.0 inch (125 mm)	N/A	53	N/A	81
060	6 inch (150mm)	N/A	72	100	100
080	8 inch (200 mm)	103	68	102	137
100	10 inch (250 mm)	78	94	152	201
120	12 inch (300 mm)	89	129	156	216
140	14 inch (350 mm)	126	169	261	341
160	16 inch (400 mm)	172	226	337	502
180	18 inch (450 mm)	150	227	296	343
200	20 inch (500 mm)	170	309	359	423
240	24 inch (600 mm)	228	456	474	685

### 3.3.2 Wafer sensors

When installing wafer sensors, there are several components that must be included and requirements that must be met.

**Figure 3-11: Wafer sensors installation components and assembly requirements**

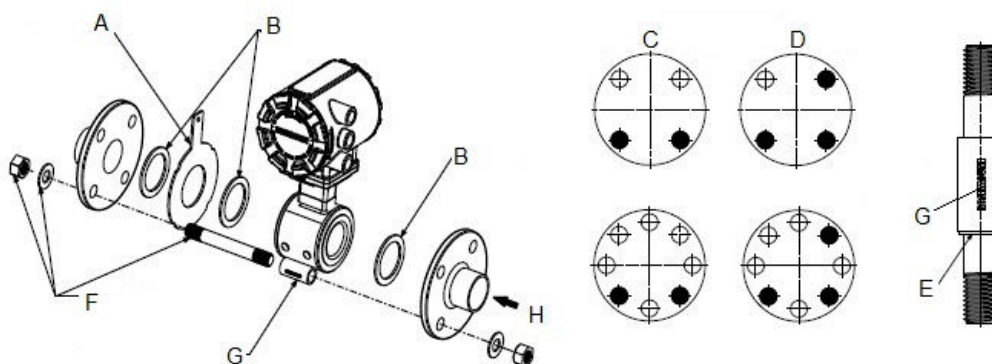

- A. Ground ring (optional)
- B. Customer supplied gaskets
- C. Spacer installation (horizontal meters)
- D. Spacer installation (vertical meters)
- E. O-ring
- F. Installation studs, nuts, and washers (optional)
- G. Wafer alignment spacer
- H. Flow

**Gaskets**

The sensor requires a gasket at each process connection. The gasket material selected must be compatible with the process fluid and operating conditions. Gaskets are required on each side of a grounding ring. See [Figure 3-11](#).

**Note**

Metallic or spiral-wound gaskets should not be used as they will damage the liner face of the sensor.

**Alignment spacers**

On 1.5 inch through 8 inch (40 through 200 mm) line sizes, alignment spacers are **required** to ensure proper centering of the wafer sensor between the process flanges. To order an Alignment Spacer Kit (quantity 3 spacers), use p/n 08711-3211-xxxx, where xxxx equals the dash number shown in [Table 3-5](#).

**Table 3-5: Alignment spacers**

Dash-no. (-xxxx)	Line size		Flange rating
	(in)	(mm)	
0A15	1.5	40	JIS 10K-20K
0A20	2	50	JIS 10K-20K
0A30	3	80	JIS 10K
0B15	1.5	40	JIS 40K
AA15	1.5	40	ASME - 150#
AA20	2	50	ASME - 150#
AA30	3	80	ASME - 150#

**Table 3-5: Alignment spacers (continued)**

Dash-no. (-xxxx)	Line size		Flange rating
	(in)	(mm)	
AA40	4	100	ASME - 150#
AA60	6	150	ASME - 150#
AA80	8	200	ASME - 150#
AB15	1.5	40	ASME - 300#
AB20	2	50	ASME - 300#
AB30	3	80	ASME - 300#
AB40	4	100	ASME - 300#
AB60	6	150	ASME - 300#
AB80	8	200	ASME - 300#
DB40	4	100	EN 1092-1 - PN10/16
DB60	6	150	EN 1092-1 - PN10/16
DB80	8	200	EN 1092-1 - PN10/16
DC80	8	200	EN 1092-1 - PN25
DD15	1.5	40	EN 1092-1 - PN10/16/25/40
DD20	2	50	EN 1092-1 - PN10/16/25/40
DD30	3	80	EN 1092-1 - PN10/16/25/40
DD40	4	100	EN 1092-1 - PN25/40
DD60	6	150	EN 1092-1 - PN25/40
DD80	8	200	EN 1092-1 - PN40
RA80	8	200	AS40871-PN16
RC20	2	50	AS40871-PN21/35
RC30	3	80	AS40871-PN21/35
RC40	4	100	AS40871-PN21/35
RC60	6	150	AS40871-PN21/35
RC80	8	200	AS40871-PN21/35

**Studs**

Wafer sensors require threaded studs. See [Figure 3-12](#) for torque sequence. Always check for leaks at the flanges after tightening the flange bolts. All sensors require a second tightening 24 hours after initial flange bolt tightening.

**Table 3-6: Stud specifications**

Nominal sensor size	Stud specifications
0.15–1-in. (4–25 mm)	316 SST ASTM A193, Grade B8M, Class 1 threaded mounted studs
1½–8-in. (40–200 mm)	CS, ASTM A193, Grade B7, threaded mounting studs



Figure 3-12: Flange bolt torquing sequence

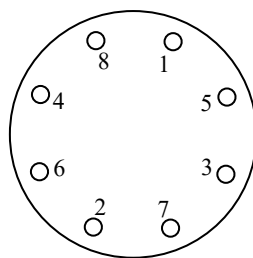

## Installation

### Procedure

1. Insert studs for the bottom side of the sensor between the pipe flanges and center the alignment spacer in the middle of the stud. See [Figure 3-11](#) for the bolt hole locations recommended for the spacers provided. Stud specifications are listed in [Table 3-6](#).
2. Place the sensor between the flanges. Make sure the alignment spacers are properly centered on the studs. For vertical flow installations slide the o-ring over the stud to keep the spacer in place. See [Figure 3-11](#). Ensure the spacers match the flange size and class rating for the process flanges. See [Table 3-5](#).
3. Insert the remaining studs, washers, and nuts.
4. Tighten to the torque specifications shown in [Table 3-7](#). Do not over-tighten the bolts or the liner may be damaged.

Table 3-7: Rosemount 8711 torque specifications

Size code	Line size	Pound-feet	Newton-meter
15F	0.15 inch (4 mm)	5	7
30F	0.30 inch (8 mm)	5	7
005	½ inch (15 mm)	5	7
010	1 inch (25 mm)	10	14
015	1.5 inch (40 mm)	15	20
020	2 inch (50 mm)	25	34
030	3 inch (80 mm)	40	54
040	4 inch (100 mm)	30	41
060	6 inch (150 mm)	50	68
080	8 inch (200 mm)	70	95

### 3.3.3 Sanitary sensors

#### IDF Fitting

The 8721 uses an IDF (international dairy federation) style fitting to connect the process connection fitting to the meter body.

### IDF Sanitary fitting torque

Hand tighten IDF nut to approximately 50 in-lbs [5 ½ Newton-meters (N-m)] of torque. Re-tighten after a few minutes until there are no leaks (up to 130 in-lbs [14 ½ Newton-meters (N-m)] of torque). Fittings that continue to leak at a higher torque may be distorted or damaged.

#### Note

Gaskets are supplied between the IDF fitting and the process connection fitting, such as a Tri-Clamp fitting, on all Rosemount 8721 Sanitary sensors except when the process connection fittings are not supplied and the only connection type is an IDF fitting.

### Gaskets

The sensor requires a gasket at each of its connections to adjacent devices or piping. The gasket material selected must be compatible with the process fluid and operating conditions.

### Alignment and clamping of user-supplied clamp

Standard plant practices should be followed when installing a magmeter with sanitary fittings. Unique torque values and bolting techniques are not required.

**Figure 3-13: Sanitary sensor gasket and clamp alignment**

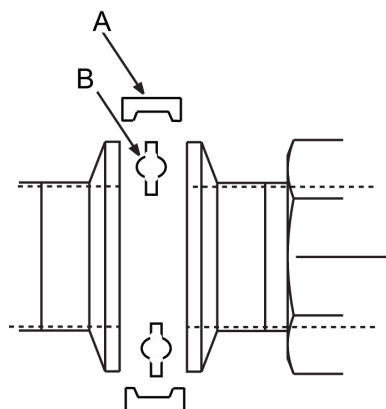

- A. User-supplied clamp
- B. User-supplied gasket

## 3.4 Process reference connection

The figures shown in this section illustrate best practice installations for process reference connections only. For installations in conductive, unlined pipe it may be acceptable to use one ground ring or one lining protector to establish a process reference connection. Earth safety ground is also required as part of this installation, but is not shown in the figures. Follow national, local, and plant electrical codes for safety ground.

Use [Table 3-8](#) to determine which process reference option to follow for proper installation.

**Table 3-8: Process reference options**

Type of pipe	Grounding straps	Grounding rings	Reference electrode	Lining protectors
Conductive unlined pipe	See <a href="#">Figure 3-14</a>	See <a href="#">Figure 3-15</a>	See <a href="#">Figure 3-17</a>	See <a href="#">Figure 3-15</a>

**Table 3-8: Process reference options (continued)**

Type of pipe	Grounding straps	Grounding rings	Reference electrode	Lining protectors
Conductive lined pipe	Insufficient grounding	See <a href="#">Figure 3-15</a>	See <a href="#">Figure 3-14</a>	See <a href="#">Figure 3-15</a>
Non-conductive pipe	Insufficient grounding	See <a href="#">Figure 3-16</a>	Not recommended	See <a href="#">Figure 3-16</a>

**Note**

For line sizes 10-inch and larger, the ground strap may come attached to the sensor body near the flange. See [Figure 3-18](#).

**Figure 3-14: Grounding straps in conductive unlined pipe or reference electrode in lined pipe**

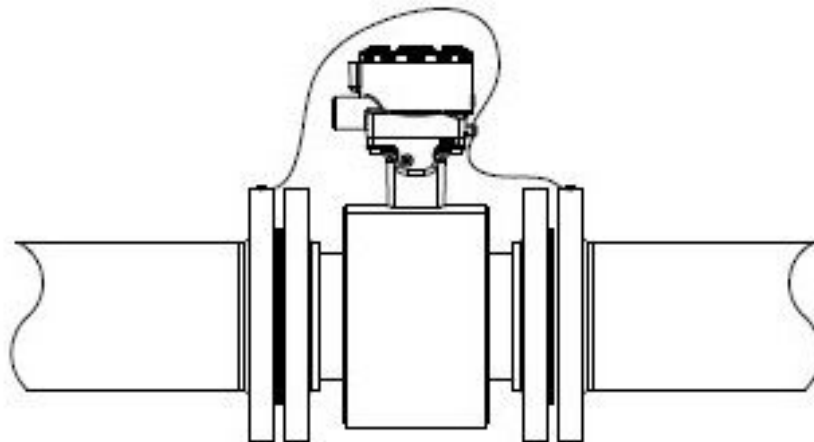

---

**Figure 3-15: Grounding with grounding rings or lining protectors in conductive pipe**

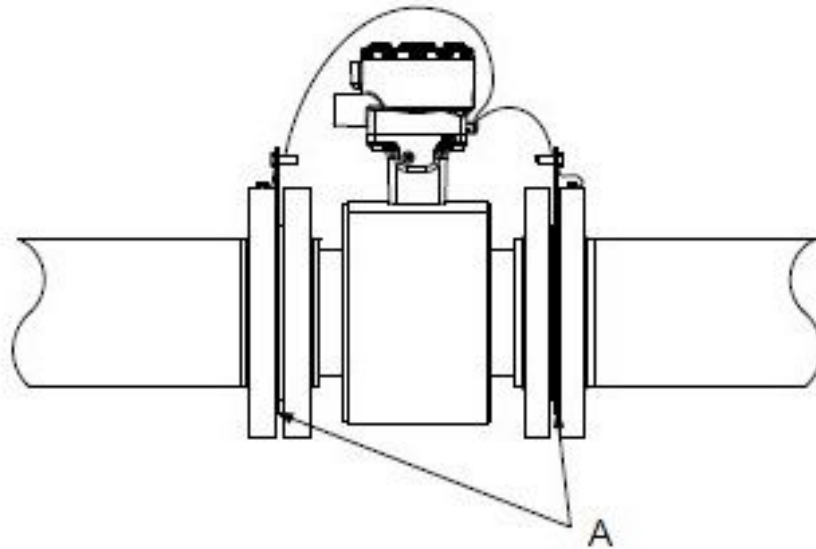

---

*A. Grounding rings or lining protectors*

---

**Figure 3-16: Grounding with grounding rings or lining protectors in non-conductive pipe**

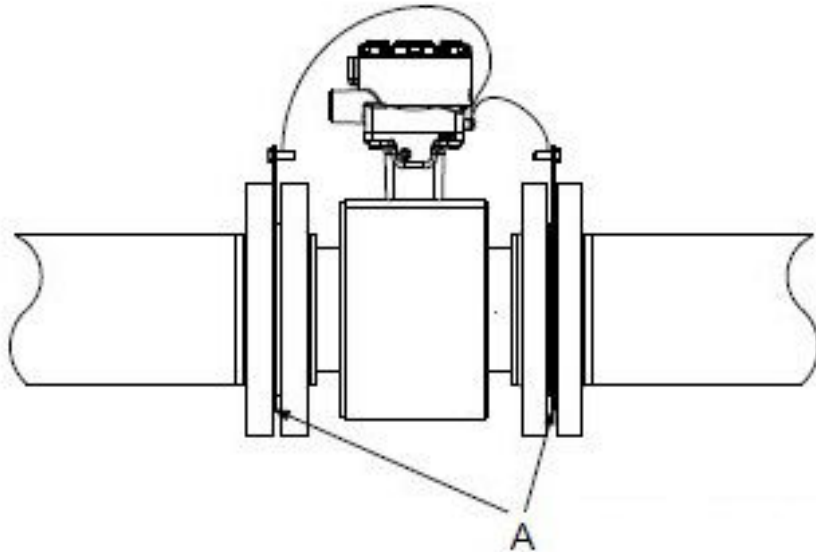

---

*A. Grounding rings or lining protectors*

---

---

**Figure 3-17: Grounding with reference electrode in conductive unlined pipe**

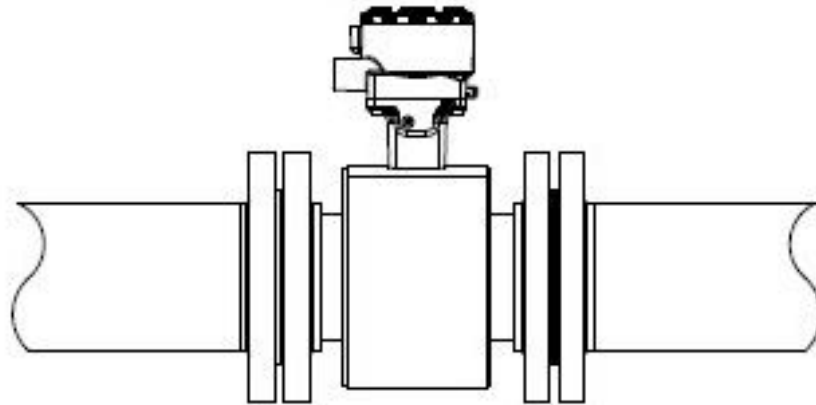

---

**Figure 3-18: Grounding for line sizes 10-in. and larger**

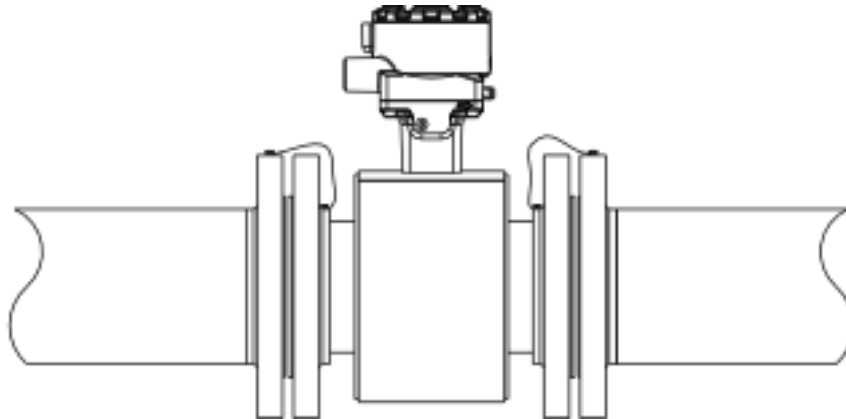



## 4 Remote Transmitter Installation

This chapter provides instructions for installing and wiring a remotely mounted transmitter.

### Related information

[Sensor Installation](#)

### 4.1 Pre-installation

Before installing the transmitter, there are several pre-installation steps that should be completed to make the installation process easier:

- Identify options and configurations that apply to your application
- Set the hardware switches if necessary
- Consider mechanical, electrical, and environmental requirements

---

#### Note

Refer to [Product specifications](#) for more detailed requirements.

---

#### Identify options and configurations

The typical transmitter installation includes a device power connection, a Modbus RS-485 output connection, and sensor coil and electrode connections. Other applications may require one or more of the following configurations or options:

- Pulse output
- Discrete input/discrete output

#### Hardware switches

The transmitter has two user-selectable hardware switches. These switches set the internal/external pulse power and transmitter security. The standard configuration for these switches when shipped from the factory is as follows:

**Table 4-1: Hardware switch default settings**

Setting	Factory configuration
Internal/external pulse power	External
Transmitter security	Off

In most cases, it is not necessary to change the setting of the hardware switches. If the switch settings need to be changed, refer to [Hardware switches](#).

Be sure to identify any additional options and configurations that apply to the installation. Keep a list of these options for consideration during the installation and configuration procedures.

#### Mechanical considerations

The mounting site for the transmitter should provide enough room for secure mounting, easy access to conduit entries, full opening of the transmitter covers, and easy readability of the Local Operator Interface (LOI) screen (if equipped).

**Figure 4-1: Rosemount 8732EM dimensional drawing**

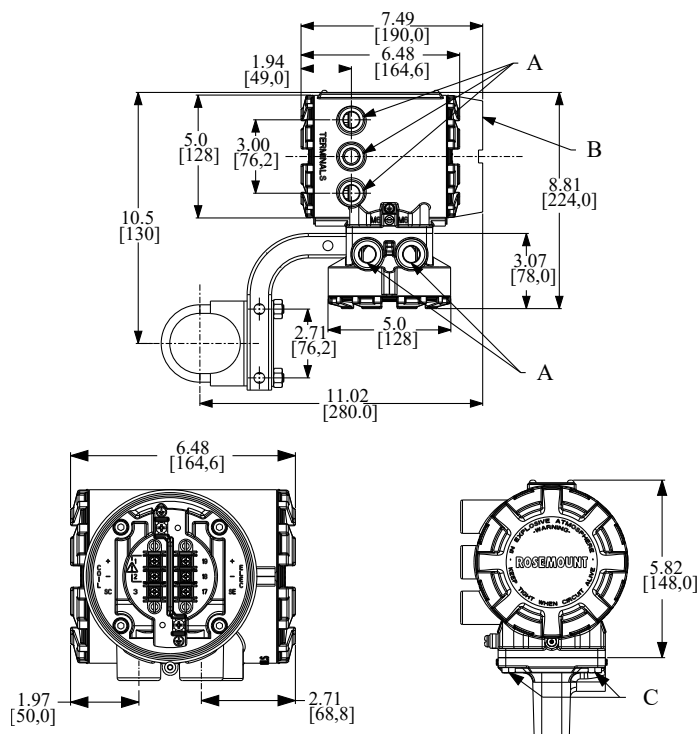

- A. Conduit entry ½-14 NPT or M20
- B. LOI cover
- C. Mounting screws

Dimensions are in inches [mm].

**Electrical considerations**

Before making any electrical connections to the transmitter, consider national, local, and plant electrical installation requirements. Be sure to have the proper power supply, conduit, and other accessories necessary to comply with these standards.

The transmitter requires external power. Ensure access to a suitable power source.

**Table 4-2: Electrical data**

Rosemount 8732EM Flow Transmitter	
Power input	AC power: 90–250 VAC, 0.45 A, 40 VA
	Standard DC power: 12–42 VDC, 1.2 A, 15 W
	Low power DC: 12–30 VDC, 0.25 A, 4 W
Pulsed circuit	Internally powered (Active): Outputs up to 12 VDC, 12.1 mA, 73 mW Externally powered (Passive): Input up to 28 VDC, 100 mA, 1 W



**Table 4-2: Electrical data (continued)**

Rosemount 8732EM Flow Transmitter	
Modbus output circuit	Internally powered (Active): Outputs up to 3.3 VDC, 100 mA, 100 mW
Termination resistors	Typically 120 ohms. Refer to the MODBUS over Serial Line Specification & Implementation Guide ( <a href="http://www.modbus.org">http://www.modbus.org</a> ) for more details.
Um	250 V
Coil excitation output	500 mA, 40 V max, 9 W max

**Environmental considerations**

To ensure maximum transmitter life, avoid extreme temperatures and excessive vibration. Typical problem areas include the following:

- High-vibration lines with integrally mounted transmitters
- Tropical or desert installations in direct sunlight
- Outdoor installations in arctic climates

Remote mounted transmitters may be installed in the control room to protect the electronics from the harsh environment and to provide easy access for configuration or service.



**Table 4-3: Transmitter housing environmental ratings**

Type	Rating
Ingress protection	IP66, IP69
NEMA	4X
Pollution Degree	2
Maximum altitude rating	<ul style="list-style-type: none"> <li>• 13,123 ft. (4000 m) at rated input power voltage (90–250 VAC)</li> <li>• 16,404 ft. (5000 m) at maximum input power voltage of 150 VAC</li> </ul>

**Note**

For complete environmental and other specifications, see [Product specifications](#).

## 4.2 Transmitter symbols

Caution symbol — check product documentation for details	
Protective conductor (grounding) terminal	

## 4.3 Mounting

Remote-mount transmitters are shipped with a mounting bracket for use on a 2-in. pipe or a flat surface.

**Figure 4-2: Rosemount 8732 transmitter mounting hardware**

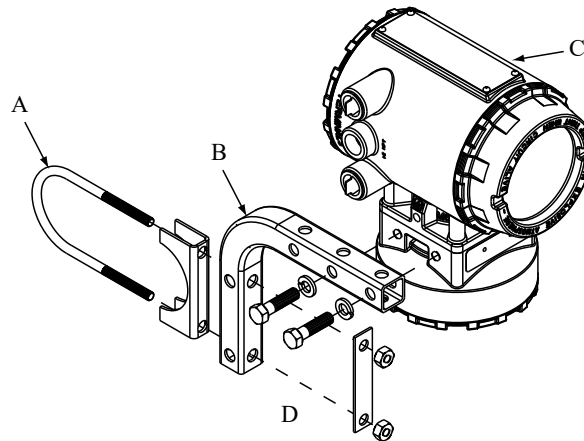

- A. U-bolt
- B. Mounting bracket
- C. Transmitter
- D. Fasteners (example configuration)

### Procedure

1. Assemble the hardware as needed to accommodate the mounting configuration.
2. Secure the transmitter to the mounting hardware.

### Postrequisites

The LOI/Display can be rotated in 90 degree increments up to 180 degrees if desired. Do not rotate more than 180 degrees in any one direction.

## 4.4 Wiring

### 4.4.1 Conduit entries and connections

Transmitter conduit entry ports can be ordered with ½-14NPT or M20 female threaded connections. Conduit connections should be made in accordance with national, local, and plant electrical codes. Unused conduit entries should be sealed with the appropriate certified plugs. The plastic shipping plugs do not provide ingress protection.

### 4.4.2 Conduit requirements

- For installations with an intrinsically safe electrode circuit, a separate conduit for the coil cable and the electrode cable may be required. Refer to [Product certifications](#).

- For installations with non-intrinsically safe electrode circuit, or when using the combination cable, a single dedicated conduit run for the coil drive and electrode cable between the sensor and the remote transmitter may be acceptable. Removal of the barriers for intrinsic safety isolation is permitted for non-intrinsically safe electrode installations.
- Bundled cables from other equipment in a single conduit are likely to create interference and noise in the system. See [Figure 4-3](#).
- Electrode cables should not be run together in the same cable tray with power cables.
- Output cables should not be run together with power cables.
- Select conduit size appropriate to feed cables through to the flowmeter.

**Figure 4-3: Best practice conduit preparation**

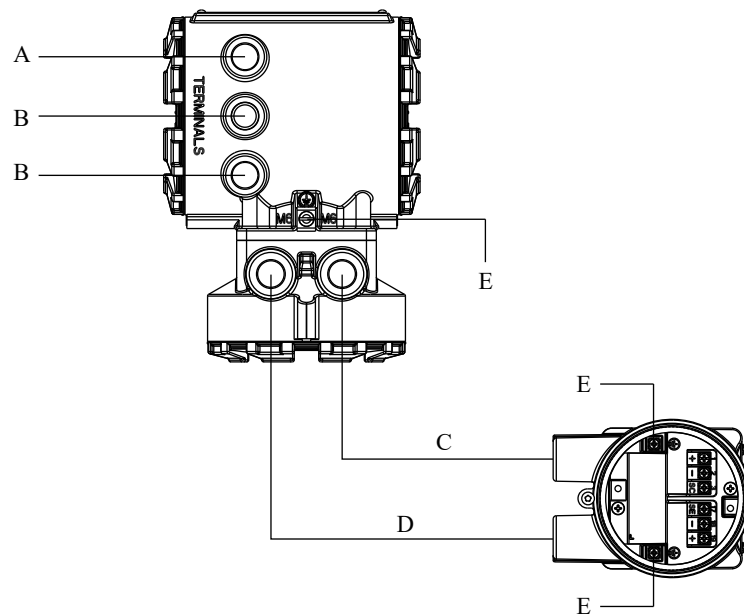

- A. Power
- B. Output
- C. Coil
- D. Electrode
- E. Safety ground

### 4.4.3 Sensor to transmitter wiring

#### Integral mount transmitters

Integral mount transmitters ordered with a sensor will be shipped assembled and wired at the factory using an interconnecting cable. Use only the factory supplied cable provided with the instrument. For replacement transmitters use the existing interconnecting cable from the original assembly. Replacement cables, if applicable, are available (see [Figure 4-4](#)).

**Figure 4-4: Replacement interconnecting cables**

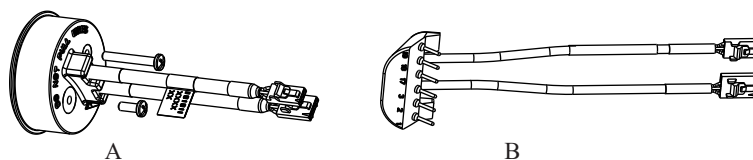

- A. Socket module 08732-CSKT-0001  
B. IMS cable 08732-CSKT-0004

**Remote mount transmitters**

Remote cable kits are available as individual component cables or as a combination coil/electrode cable. They can be ordered directly using the kit numbers shown in Table 4-4, Table 4-5, and Table 4-6. Equivalent Alpha cable part numbers are also provided as an alternative. To order cable, specify length as quantity desired. Equal length of component cables is required.

Examples:

- 25 feet = Qty (25) 08732-0065-0001
- 25 meters = Qty (25) 08732-0065-0002

**Table 4-4: Component cable kits - standard temperature (-20 °C to 75 °C)**

Cable kit #	Description	Individual cable	Alpha p/n
08732-0065-0001 (feet)	Kit, component cables, Std temp (includes Coil and Electrode)	Coil Electrode	2442C 2413C
08732-0065-0002 (meters)	Kit, component cables, Std temp (includes Coil and Electrode)	Coil Electrode	2442C 2413C
08732-0065-0003 (feet)	Kit, component cables, Std temp (includes Coil and I.S. Electrode)	Coil Intrinsically Safe Blue Electrode	2442C Not available
08732-0065-0004 (meters)	Kit, component cables, Std temp (includes Coil and I.S. Electrode)	Coil Intrinsically Safe Blue Electrode	2442C Not available

**Table 4-5: Component cable kits - extended temperature (-50 °C to 125 °C)**

Cable kit #	Description	Individual cable	Alpha p/n
08732-0065-1001 (feet)	Kit, Component Cables, Ext Temp. (includes Coil and Electrode)	Coil Electrode	Not available Not available
08732-0065-1002 (meters)	Kit, Component Cables, Ext Temp. (includes Coil and Electrode)	Coil Electrode	Not available Not available
08732-0065-1003 (feet)	Kit, Component Cables, Ext Temp. (includes Coil and I.S. Electrode)	Coil Intrinsically Safe Blue Electrode	Not available Not available
08732-0065-1004 (meters)	Kit, Component Cables, Ext Temp. (includes Coil and I.S. Electrode)	Coil Intrinsically Safe Blue Electrode	Not available Not available

**Table 4-6: Combination cable kits - coil and electrode cable (-20 °C to 80 °C)**

Cable kit #	Description
08732-0065-2001 (feet)	Kit, Combination Cable, Standard
08732-0065-2002 (meters)	
08732-0065-3001 (feet)	Kit, Combination Cable, Submersible (80 °C dry/60 °C Wet) (33 ft. Continuous)
08732-0065-3002 (meters)	

**Cable requirements**

Shielded twisted pairs or triads must be used. For installations using the individual coil drive and electrode cable, see [Figure 4-5](#). Cable lengths should be limited to less than 500 ft. (152 m). Consult factory for length between 500-1000 ft. (152-304 m). Equal length cable is required for each. For installations using the combination coil drive/electrode cable, see [Figure 4-6](#). Combination cable lengths should be limited to less than 330 ft. (100 m).

**Figure 4-5: Individual component cables**

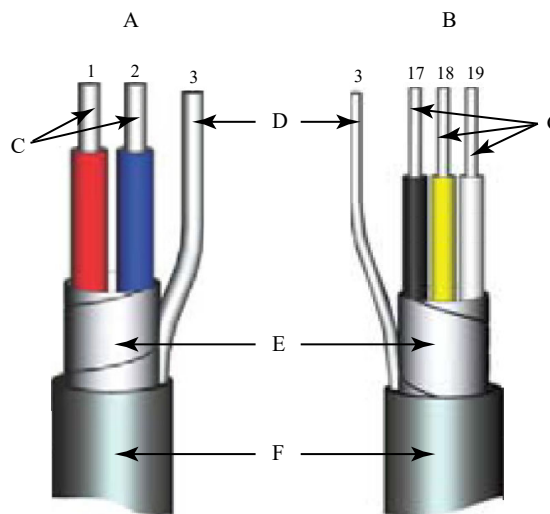

- A. Coil drive
  - B. Electrode
  - C. Twisted, stranded, insulated 14 AWG conductors
  - D. Drain
  - E. Overlapping foil shield
  - F. Outer jacket
  - G. Twisted, stranded, insulated 20 AWG conductors
- 1 = Red
  - 2 = Blue
  - 3 = Drain
  - 17 = Black
  - 18 = Yellow
  - 19 = White

**Figure 4-6: Combination coil and electrode cable**

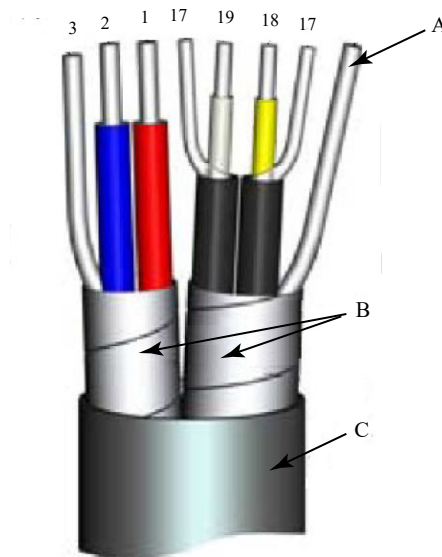

- A. *Electrode shield drain*
- B. *Overlapping foil shield*
- C. *Outer jacket*

- 1 = Red
- 2 = Blue
- 3 = Drain
- 17 = Reference
- 18 = Yellow
- 19 = White

### **Cable preparation**

Prepare the ends of the coil drive and electrode cables as shown in [Figure 4-7](#). Remove only enough insulation so that the exposed conductor fits completely under the terminal connection. Best practice is to limit the unshielded length (D) of each conductor to less than one inch. Excessive removal of insulation may result in an unwanted electrical short to the transmitter housing or other terminal connections. Excessive unshielded length, or failure to connect cable shields properly, may also expose the unit to electrical noise, resulting in an unstable meter reading.

Figure 4-7: Cable ends

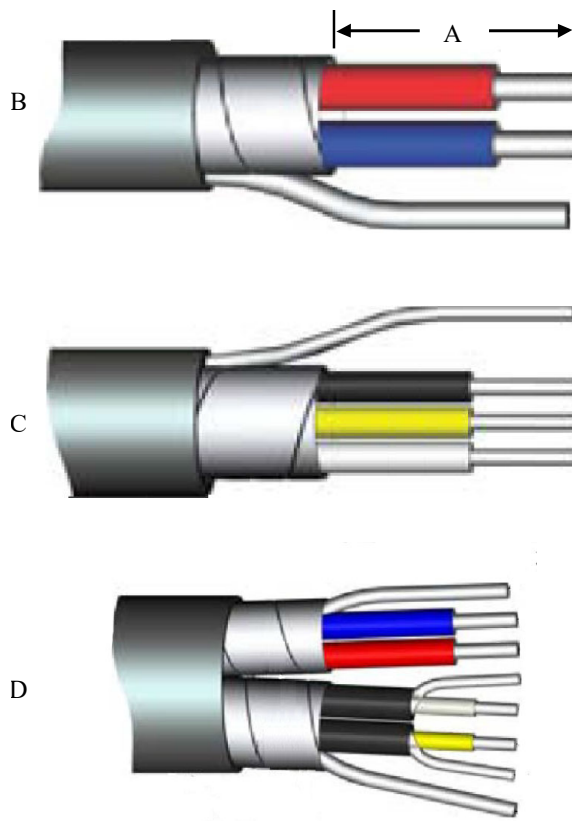

- A. Unshielded length
- B. Coil
- C. Electrode
- D. Combination

**⚠ WARNING**

Shock hazard! Potential shock hazard across remote junction box terminals 1 and 2 (40 V).

**⚠ WARNING**

Explosion hazard! Electrodes exposed to process. Use only compatible transmitter and approved installation practices. For process temperatures greater than 284 °F (140 °C), use a wire rated for 257 °F (125 °C).

### Remote junction box terminal blocks

Figure 4-8: Remote junction box views

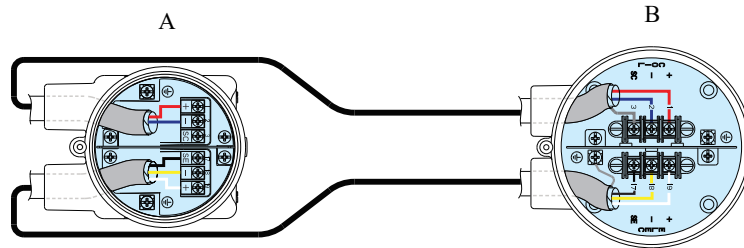

- A. Sensor
- B. Transmitter

#### Note

Junction box appearance and configuration may vary, but terminal numbering is consistent for all junction box types.

Table 4-7: Sensor/transmitter wiring

Wire color	Sensor terminal	Transmitter terminal
Red	1	1
Blue	2	2
Coil drain	3 or float	3
Black	17	17
Yellow	18	18
White	19	19
Electrode drain	⊕ or float	⊕

#### Note

For hazardous locations, refer to [Product certifications](#).

## 4.4.4

### Power and I/O terminal blocks

Remove the back cover of the transmitter to access the terminal block.

#### Note

To connect pulse output and/or discrete input/output, and for installations with intrinsically safe outputs, refer to [Product certifications](#).



Figure 4-9: Terminal blocks

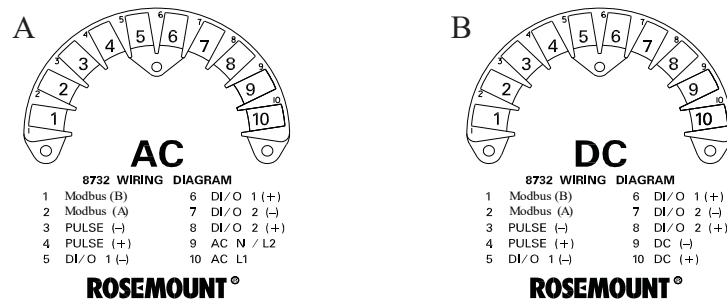

- A. AC version
- B. DC version

Table 4-8: Power and I/O terminals

Terminal number	AC version	DC version
1	Modbus (B)	Modbus (B)
2	Modbus (A)	Modbus (A)
3	Pulse (-)	Pulse (-)
4	Pulse (+)	Pulse (+)
5 <sup>(1)</sup>	Discrete I/O 1 (-)	Discrete I/O 1 (-)
6 <sup>(1)</sup>	Discrete I/O 1 (+)	Discrete I/O 1 (+)
7 <sup>(1)</sup>	Discrete Out 2 (-)	Discrete Out 2 (-)
8 <sup>(1)</sup>	Discrete Out 2 (+)	Discrete Out 2 (+)
9	AC (Neutral)/L2	DC (-)
10	AC L1	DC (+)

<sup>(1)</sup> Only available with ordering code AX.

## 4.4.5 Powering the transmitter

Before connecting power to the transmitter, be sure to have the necessary electrical supplies and required power source:

- The AC powered transmitter requires 90–250 VAC (50/60 Hz).
- The DC (standard) powered transmitter requires 12–42 VDC.
- The DC **low power** transmitter requires 12–30 VDC.

Wire the transmitter according to national, local, and plant electrical requirements.

If installing in a hazardous location, verify that the meter has the appropriate hazardous area approval. Each meter has a hazardous area approval tag attached to the top of the transmitter housing.

### Supply wire requirements

Use 10–18 AWG wire rated for the proper temperature of the application. For wire 10–14 AWG, use lugs or other appropriate connectors. For connections in ambient temperatures above 122 °F (50 °C), use a wire rated for 194 °F (90 °C). For DC powered transmitters with extended cable lengths, verify that there is a minimum of 12 VDC at the terminals of the transmitter with the device under load.

### Electrical disconnect requirements

Connect the device through an external disconnect or circuit breaker per national and local electrical code.

### Overcurrent protection

The transmitter requires overcurrent protection of the supply lines. Fuse rating and compatible fuses are shown in [Line power fuses](#).

### Installation category

The installation category for the transmitter is OVERVOLTAGE CAT II.

### AC power system installation requirements

#### Neutral-earth power requirements

The power system must have a neutral that is locally bonded to earth, or provide both line to earth and neutral to earth voltage limitation of no more than 250 VAC.

#### Power line impedance

Sources of inductance on the AC power system, such as isolation transformers, must be limited to less than 1 mH at 120 VAC, and 2 mH at 240 VAC.

### AC power supply requirements

Units powered by 90 - 250 VAC have the following power requirements. Peak inrush is 35.7 A at 250 VAC supply, lasting approximately 1 ms. Inrush for other supply voltages can be estimated with:  $\text{Inrush (Amps)} = \text{Supply (Volts)} / 7.0$

**Figure 4-10: AC current requirements**

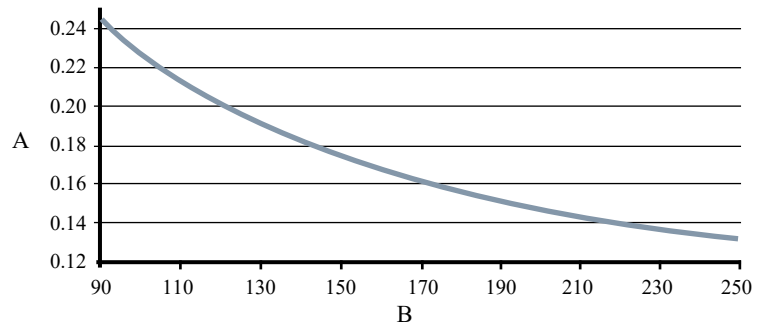

- A. Supply current (amps)
- B. Power supply (VAC)

**Figure 4-11: Apparent power**

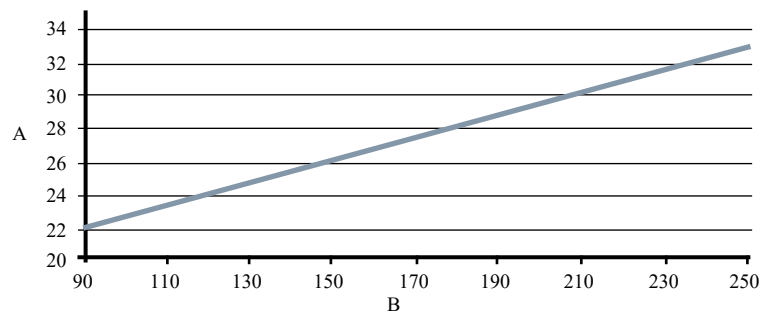

- A. Apparent power (VA)
- B. Power supply (VAC)

**DC power supply requirements**

Standard DC units powered by 12 VDC power supply may draw up to 1.2 A of current steady state. Low power DC units may draw up to 0.25 A of current steady state. Peak inrush is 42 A at 42 VDC supply, lasting approximately 1 ms. Inrush for other supply voltages can be estimated with:  $\text{Inrush (Amps)} = \text{Supply (Volts)} / 1.0$

**Figure 4-12: DC current requirements**

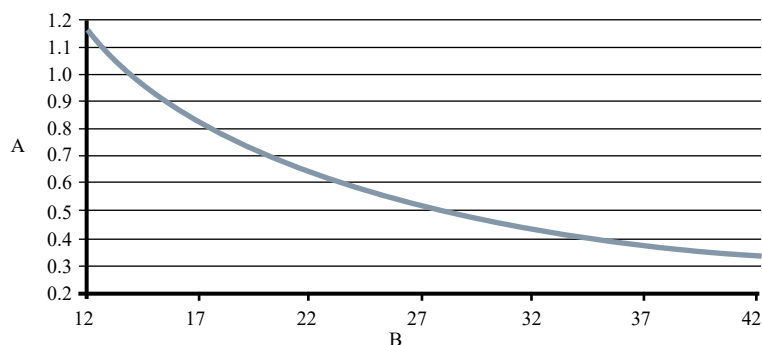

A. Supply current (amps)

B. Power supply (VDC)

**Figure 4-13: Low power DC current requirements**

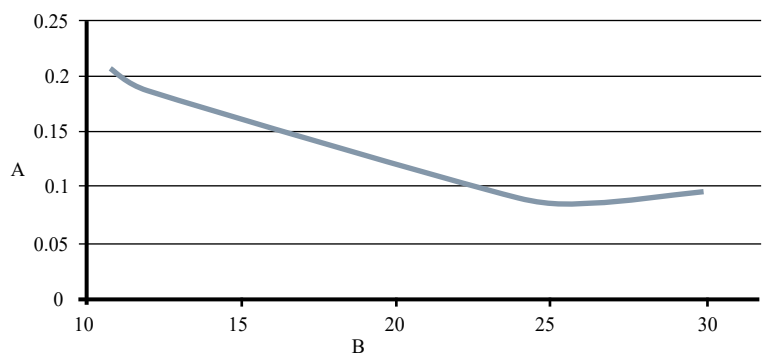

A. Supply current (amps)

B. Power supply (VDC)

**Table 4-9: Fuse requirements**

Power system	Power supply	Fuse rating	Manufacturer
AC power	90–250 VAC	2 Amp quick acting	Bussman AGC2 or equivalent
DC power	12–42 VDC	3 Amp quick acting	Bussman AGC3 or equivalent
DC low power	12–30 VDC	3 Amp quick acting	Bussman AGC3 or equivalent

**Power terminals**

For AC powered transmitter (90–250 VAC, 50/60 Hz):

- Connect AC Neutral to terminal 9 (AC N/L2) and AC Line to terminal 10 (AC/L1).

For DC powered transmitter:

- Connect negative to terminal 9 (DC -) and positive to terminal 10 (DC +).
- DC powered units may draw up to 1.2 A.

### Cover jam screw

For flow meters shipped with a cover jam screw, the screw should be installed after the instrument has been wired and powered up. Follow these steps to install the cover jam screw:

1. Verify the cover jam screw is completely threaded into the housing.
2. Install the housing cover and verify the cover is tight against the housing.
3. Using a 2.5 mm hex wrench, loosen the jam screw until it contacts the transmitter cover.
4. Turn the jam screw an additional  $\frac{1}{2}$  turn counterclockwise to secure the cover.

---

#### Note

Application of excessive torque may strip the threads.

---

5. Verify the cover cannot be removed.



## 5 Basic configuration

Once the magnetic flowmeter is installed and power has been supplied, the transmitter must be configured through the basic setup. These parameters can be configured through either an LOI or a Modbus host. Configuration settings are saved in nonvolatile memory within the transmitter. Descriptions of more advanced functions are included in [Advanced Configuration Functionality](#).

### 5.1 Cover jam screw

For flow meters shipped with a cover jam screw, the screw should be installed after the instrument has been wired and powered up. Follow these steps to install the cover jam screw:

#### Procedure

1. Verify the cover jam screw is completely threaded into the housing.
2. Install the housing cover and verify the cover is tight against the housing.
3. Using a 2.5 mm hex wrench, loosen the jam screw until it contacts the transmitter cover.
4. Turn the jam screw an additional ½ turn counterclockwise to secure the cover.

---

#### Note

Application of excessive torque may strip the threads.

---

5. Verify the cover cannot be removed.

### 5.2 Basic setup

#### Tag (registers 68–71)

Tag is the quickest and shortest way of identifying and distinguishing between transmitters. Transmitters can be tagged according to the requirements of your application. The tag may be up to eight characters long.

#### Flow units (register 61)

The flow units variable specifies the format in which the flow rate will be displayed. Units should be selected to meet your particular metering needs.

**Table 5-1: Volume units**

Register value	Units
241	Barrels (31 gal)/sec
242	Barrels (31 gal)/min
243	Barrels (31 gal)/hour
244	Barrels (31 gal)/day
132	Barrels (42 gal)/sec
133	Barrels (42 gal)/min
134	Barrels (42 gal)/hour
135	Barrels (42 gal)/day

**Table 5-1: Volume units (continued)**

Register value	Units
248	Cubic cm/minute
26	Cubic feet/second
15	Cubic feet/minute
130	Cubic feet/hour
27	Cubic feet/day
28	Cubic meters/second
131	Cubic meters/minute
19	Cubic meters/hour
29	Cubic meters/day
22	Gallons/second
16	Gallons/minute
136	Gallons/hour
23	Millions gallons/day
235	Gallons/day
137	Imperial gallons/sec
18	Imperial gallons/min
30	Imperial gallons/hour
31	Imperial gallons/day
24	Liters/second
17	Liters/minute
138	Liters/hour
240	Liters/day

**Table 5-2: Mass units**

Register value	Units
73	Kilograms/second
74	Kilograms/minute
75	Kilograms/hour
76	Kilograms/day
77	Metric ton/minute
78	Metric ton/hour
79	Metric ton/day
80	Pounds/second
81	Pounds/minute
82	Pounds/hour
83	Pounds/day



**Table 5-2: Mass units (continued)**

Register value	Units
84	Short tons/minute
85	Short tons/hour
86	Short tons/day

**Table 5-3: Other units**

Register value	Units
20	Feet/second (default)
21	Meters/second
253	Special units (see <a href="#">Configure special units</a> )

**Line size (register 65)**

The line size (sensor size) must be set to match the actual sensor connected to the transmitter.

Register value	Line size
0	0.10-in. (2 mm)
1	0.15-in. (4 mm)
2	0.25-in. (6 mm)
3	0.30-in. (8 mm)
4	0.50-in. (15 mm)
5	0.75-in. (18 mm)
6	1-in. (25 mm)
7	1.5-in. (40 mm)
8	2-in. (50 mm)
9	2.5-in. (65 mm)
10	3-in. (80 mm) (default)
11	4-in. (100 mm)
12	5-in. (125 mm)
13	6-in. (150 mm)
14	8-in. (200 mm)
15	10-in. (250 mm)
16	12-in. (300 mm)
17	14-in. (350 mm)
18	16-in. (400 mm)
19	18-in. (450 mm)
20	20-in. (500 mm)
21	24-in. (600 mm)
22	28-in. (700 mm)

Register value	Line size
23	30-in. (750 mm)
24	32-in. (800 mm)
25	36-in. (900 mm)
26	40-in. (1000 mm)
27	42-in. (1050 mm)
28	44-in. (1100 mm)
29	48-in. (1200 mm)
30	54-in. (1350 mm)
31	56-in. (1400 mm)
32	60-in. (1500 mm)
33	64-in. (1600 mm)
34	66-in. (1650 mm)
35	72-in. (1800 mm)
36	78-in. (1950 mm)

#### Calibration number (registers 413–420)

The sensor calibration number is a 16-digit number generated at the factory during flow calibration and is unique to each sensor and is located on the sensor tag.

## 5.3 Modbus configuration

Each register is identified by its address (or starting address). Depending on the PLC that will be used to communicate with the transmitter, you may need to subtract 1 from the address or starting address of the register. Refer to your PLC documentation to know if this applies to you.

#### Address (register 109)

Configures the address of the transmitter for the Modbus network.

#### Floating point byte order (register 110)

Sets the order that information is sent by the transmitter.

Register value	Byte order
0	0-1-2-3 (default)
1	2-3-0-1
2	1-0-3-2
3	3-2-1-0

#### Baud rate (register 115)

Sets the communication speed of the transmitter.

Register value	Baud rate
0	1200

Register value	Baud rate
1	2400
2	4800
3	9600
4	19200 (default)
5	38400
6	57600
7	115200

#### Parity (register 116)

Used to configure error-checking methodology for the data.

Register value	Parity
0	No parity
1	Odd
2	Even (default)

#### Stop bits (register 117)

Sets the last bit of the data packet.

Register value	Stop bits
1	1 bit (default)
2	2 bits

## 5.4 Local operator interface (LOI)

To activate the optional LOI, press the DOWN arrow.

Use the UP, DOWN, LEFT(E), and RIGHT arrows to navigate the menu structure.

The display can be locked to prevent unintentional configuration changes. When the display lock is activated, a lock symbol will appear in the lower right hand corner of the display. To deactivate the display lock, hold the UP arrow for three seconds and follow the on-screen instructions. Once deactivated, the lock symbol will no longer appear in the lower right hand corner of the display.



## 6 Advanced installation details

### 6.1 Hardware switches

The electronics are equipped with two user-selectable hardware switches. These switches set the Transmitter Security and Internal/External Pulse Power.

#### 6.1.1 Transmitter security

The **SECURITY** switch allows the user to lock out any configuration changes attempted on the transmitter.

- When the security switch is in the **ON** position, the configuration can be viewed but no changes can be made.
- When the security switch is in the **OFF** position, the configuration can be viewed and changes can be made.

The switch is in the **OFF** position when the transmitter is shipped from the factory.

---

**Note**

The flow rate indication and totalizer functions remain active when the **SECURITY** switch is in either position.

---

#### 6.1.2 Internal/external pulse power

The pulse loop can be powered internally by the transmitter or externally or by an external power supply. The **PULSE** switch determines the source of the pulse loop power.

- When the switch is in the **INTERNAL** position, the pulse loop is powered internally by the transmitter.
- When the switch is in the **EXTERNAL** position, a 5–28 VDC external supply is required. For more information about pulse external power, see [Connect pulse output](#).

The switch is in the **EXTERNAL** position when the transmitter is shipped from the factory.

#### 6.1.3 Changing hardware switch settings

---

**Note**

The hardware switches are located on the top side of the electronics board and changing their settings requires opening the electronics housing. If possible, carry out these procedures away from the plant environment in order to protect the electronics.

---

Figure 6-1: Electronics Stack and Hardware Switches

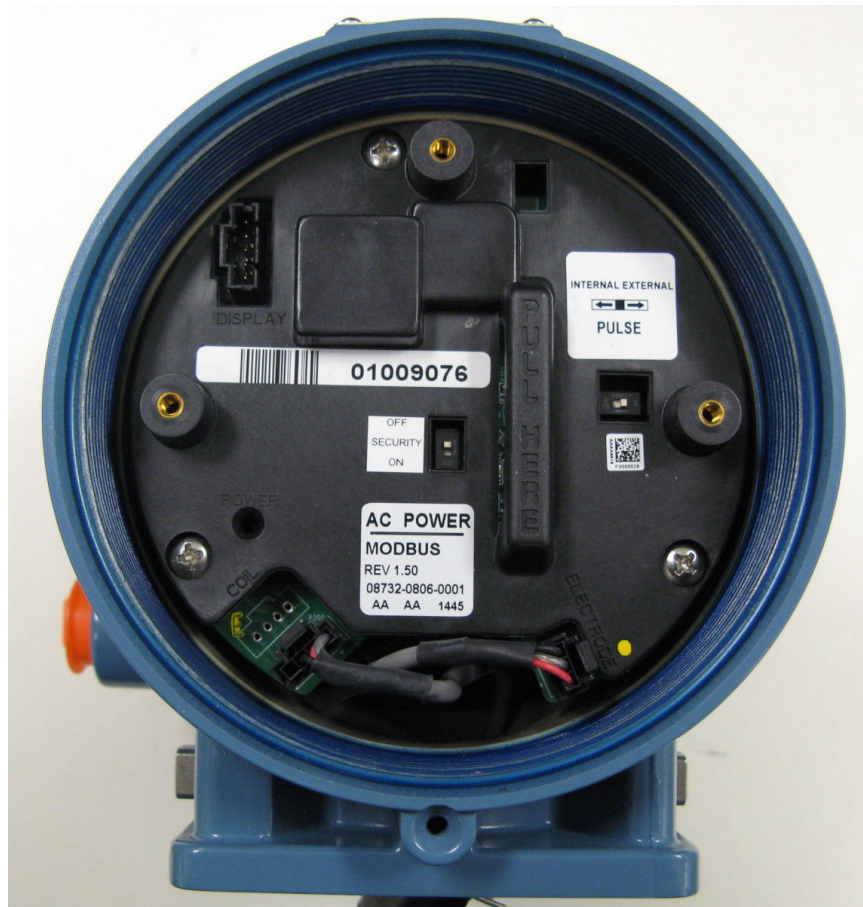

#### Procedure

1. Place the control loop into manual control.
2. Disconnect power to the transmitter
3. Remove the electronics compartment cover.  
If the cover has a cover jam screw, this must be loosened prior to removal of the cover.
4. Remove the LOI/Display, if applicable.
5. Identify the location of each switch (see [Figure 6-1](#)).
6. Change the setting of the desired switches with a small, non-metallic tool.
7. Replace the LOI/Display, if applicable.
8. Replace the electronics compartment cover.  
If the cover has a cover jam screw, this must be tightened to comply with installation requirements. See [Cover jam screw](#) for details on the cover jam screw.
9. Return power to the transmitter and verify the flow measurement is correct.
10. Return the control loop to automatic control.

## 6.2 Pulse output and discrete input/outputs

There are three additional loop connections available on the Transmitter:

- Pulse output - used for external or remote totalization (see [Pulse output](#)).
- Discrete I/O Channel 1 can be configured as discrete input or discrete output (see [Discrete input/output](#)).
- Discrete I/O Channel 2 can be configured as discrete output only (see [Discrete input/output](#)).

### 6.2.1 Connect pulse output

The pulse output function provides a galvanically isolated frequency signal that is proportional to the flow through the sensor. The signal is typically used in conjunction with an external totalizer or control system.

---

#### Note

The pulse output can be internally or externally powered, and the **PULSE** switch must be set accordingly (the default setting is **EXTERNAL**).

---

#### External

The transmitter supports a pulse output with an external power supply that meets the following requirements:

- Supply voltage: 5 to 24 VDC
- Maximum current: 100 mA
- Maximum power: 1.0 W
- Load resistance: 200 to 10k Ohms (typical value 1k Ohms). Refer to the figure indicated:

Supply voltage	Resistance vs cable length
5 VDC	See <a href="#">Figure 6-2</a>
12 VDC	See <a href="#">Figure 6-3</a>
24 VDC	See <a href="#">Figure 6-4</a>

- Pulse mode: Fixed pulse width or 50% duty cycle
- Pulse duration: 0.1 to 650 ms (adjustable)
- Maximum pulse frequency: 5,000 Hz
- FET switch closure: solid state switch

Figure 6-2: 5 VDC Supply

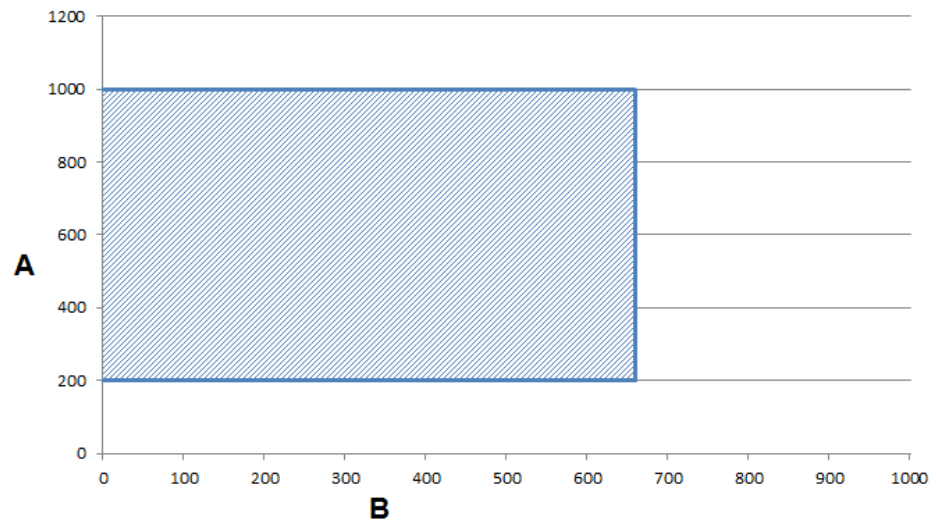

- A. Resistance ( $\Omega$ )
- B. Cable length (feet)

At 5000 Hz operation with a 5 VDC supply, pull-up resistances of 200 to 1000 Ohms allow cable lengths up to 660 ft (200 m).

Figure 6-3: 12 VDC Supply

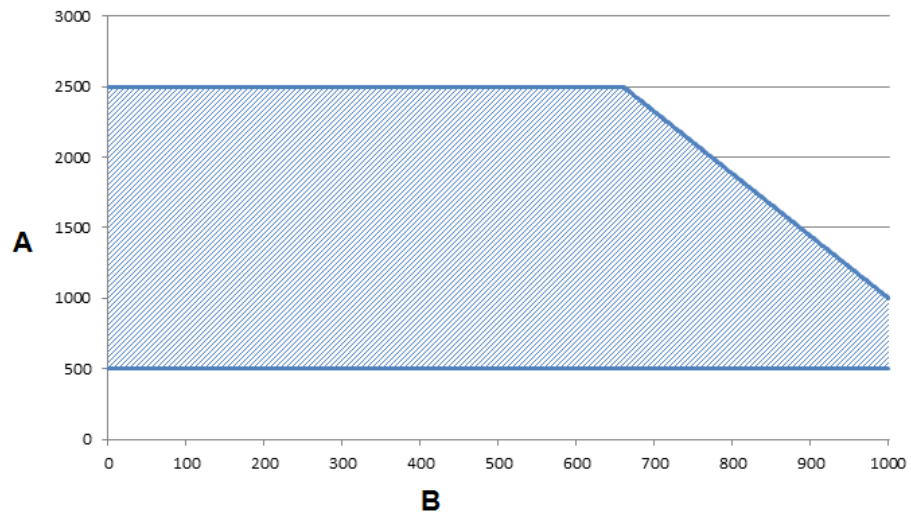

- A. Resistance ( $\Omega$ )
- B. Cable length (feet)

At 5000 Hz operation with a 12 VDC supply, pull-up resistances of 500 to 2500 Ohms allow cable lengths up to 660 ft (200 m). Resistances from 500 to 1000 Ohms allow a cable length of 1000 ft (330 m).



Figure 6-4: 24 VDC Supply

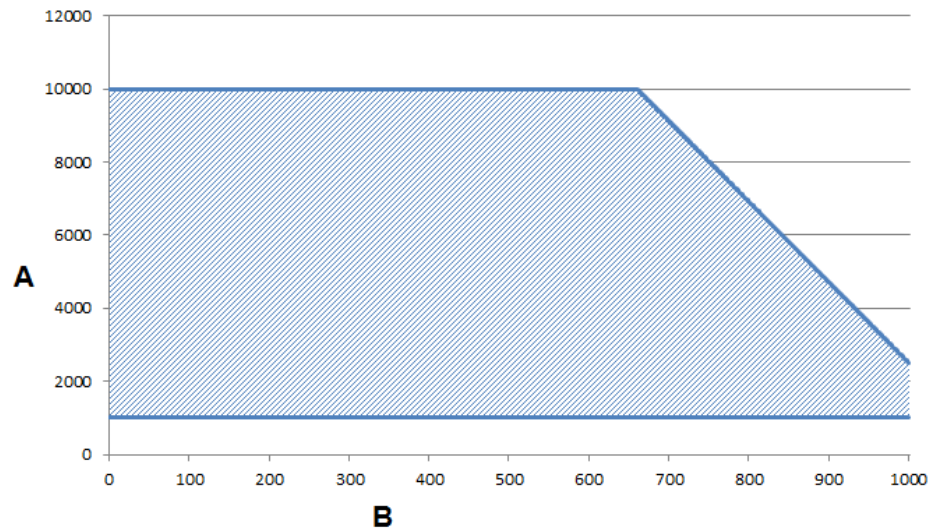

- A. Resistance ( $\Omega$ )
- B. Cable length (feet)

At 5000 Hz operation with a 24 VDC supply, pull-up resistances of 1000 to 10,000 Ohms allow cable lengths up to 660 ft (200 m). Resistances from 1000 to 2500 Ohms allow a cable length of 1000 ft (330 m).

### Connecting an external power supply

**Note**

Total loop impedance must be sufficient to keep loop current below maximum rating. A resistor can be added in the loop to raise impedance.

**Figure 6-5: Connecting an electromechanical totalizer/counter with external power supply**

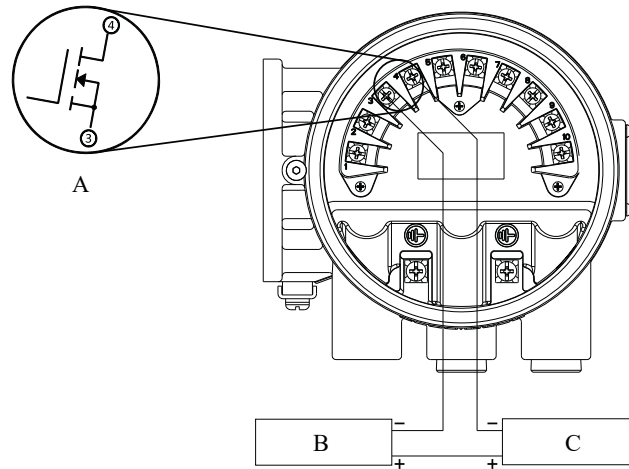

- A. Schematic showing FET between terminal 3 and 4
- B. 5–24 VDC power supply
- C. Electro-mechanical counter

**Figure 6-6: Connecting to an electronic totalizer/counter with external power supply**

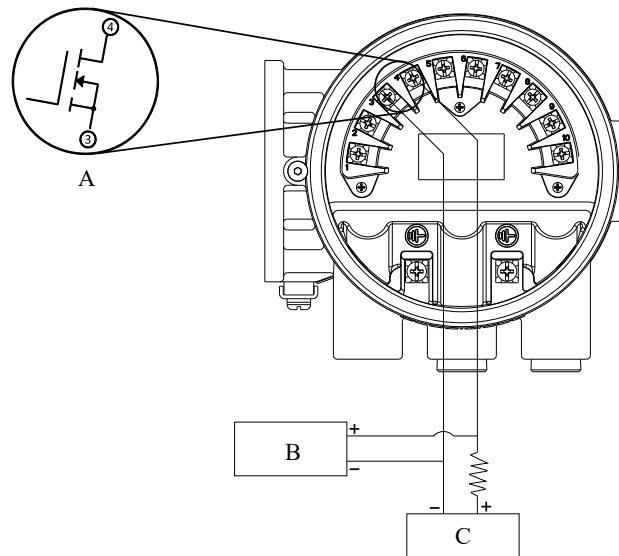

- A. Schematic showing FET between terminal 3 and 4
- B. Electronic counter
- C. 5–24 VDC power supply

**Procedure**

1. Ensure the power source and connecting cable meet the requirements outlined previously.

2. Turn off the transmitter and pulse output power sources.
3. Run the power cable to the transmitter.
4. Connect - DC to terminal 3.

## Internal power supply

For an internally powered pulse output, the supply voltage from the transmitter can be up to 12 VDC. Connect the transmitter directly to the counter as shown. Internal pulse power can only be used with an electronic totalizer or counter and cannot be used with an electromechanical counter.

**Figure 6-7: Connecting to an electronic totalizer/counter with internal power supply**

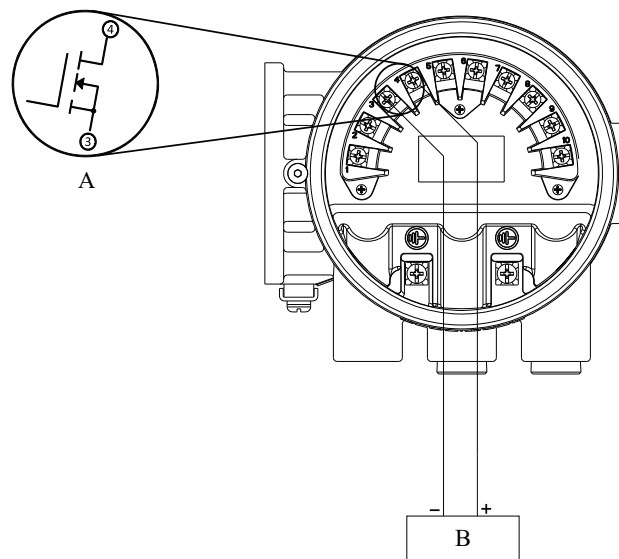

- A. Schematic showing FET between terminal 3 and 4  
B. Electronic counter

### Procedure

1. Turn off the transmitter.
2. Connect wires from the counter to the transmitter as shown.

## 6.2.2 Connect discrete output

The discrete output control function can be configured to drive an external signal to indicate zero flow, reverse flow, empty pipe, diagnostic status, flow limit, or transmitter status. The following requirements apply:

- Supply Voltage: 5 to 28 VDC
- Maximum Voltage: 28 VDC at 240 mA
- Switch Closure: solid state relay

**Figure 6-8: Connect discrete output to relay or control system input**

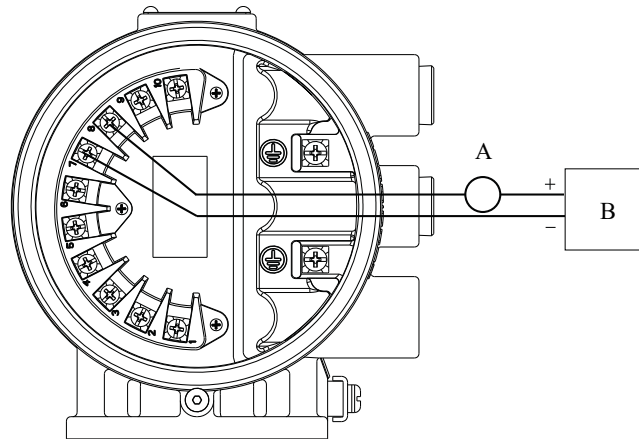

- A. Control relay or input
- B. 5–28 VDC power supply

**Note**

Total loop impedance must be sufficient to keep loop current below maximum current rating. A resistor can be added in the loop to raise impedance.

For discrete output control, connect the power source and control relay to the transmitter. To connect external power for discrete output control, complete the following steps:

**Procedure**

1. Ensure the power source and connecting cable meet the requirements outlined previously.
2. Turn off the transmitter and discrete power sources.
3. Run the power cable to the transmitter.
4. Connect the DC power supply to the transmitter as shown.

## 6.2.3 Connect discrete input

The discrete input can provide positive zero return (PZR) or reset totalizer (A, B, C, or all totals).

**Note**

If a particular totalizer is configured to be not resettable, the totalizer will not be reset with this function.

The following requirements apply:

- Supply voltage: 5 VDC to 28 VDC
- Current: 1.5 mA to 20 mA
- Input Impedance: 2.5 k plus 1.2 V diode drop. See [Figure 6-10](#).

**Figure 6-9: Connecting Discrete Input**

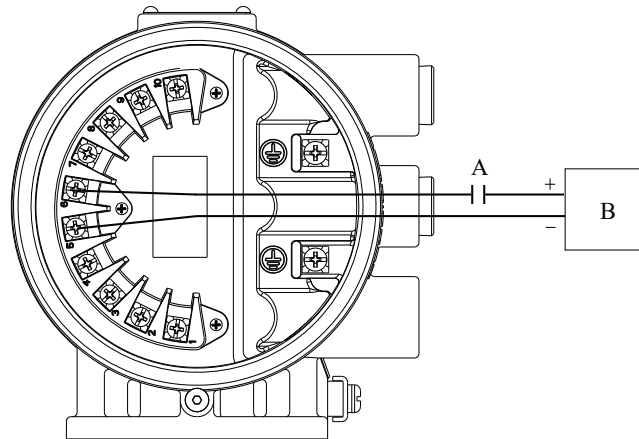

- A. Relay contactor control system output
- B. 5–28 VDC power supply

**Figure 6-10: Discrete Input Operating Range**

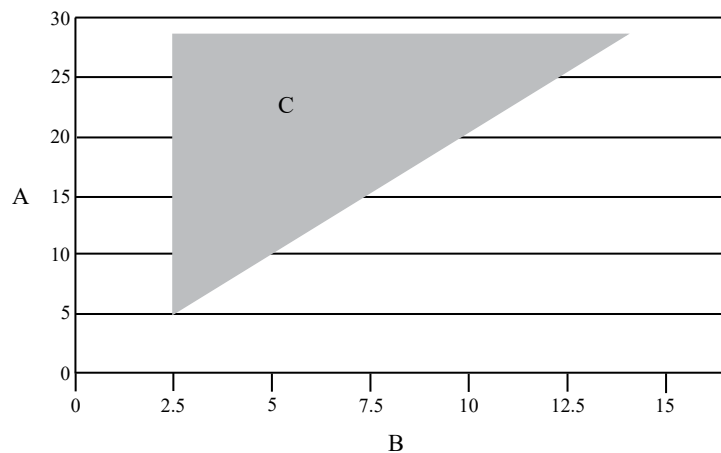

- A. Supply voltage
- B. Series resistance  $\Omega_{in} + \Omega_{ext}$  (KΩ)
- C. Digital input operating range

To connect the discrete input, complete the following steps.

**Procedure**

1. Ensure the power source and connecting cable meet the requirements outlined previously.
2. Turn off the transmitter and discrete power sources.
3. Run the power cable to the transmitter.
4. Connect the wires to the transmitter as shown.

## 6.3 Coil housing configuration

The coil housing provides physical protection of the coils and other internal components from contamination and physical damage that might occur in an industrial environment. The coil housing is an all-welded and gasket-free design.

The 8705 model is available in four coil housing configurations. Configurations are identified by the M0, M1, M2, or M4 options codes found in the model number. The 8711 and 8721 models are only available in one coil housing coil configuration; a separate option code is not available.

### 6.3.1 Standard coil housing configuration

The standard coil housing configuration is a factory-sealed all-welded enclosure and is available for the following models (see [Figure 6-11](#)):

- 8705 with option code M0 - 8705xxxxxxxxM0
- 8711 with option code M/L - 8711xxxxxxxxM/L
- 8721 with option code R/U - 8721xxxxxxxxR/U

**Figure 6-11: Standard Housing Configuration (8705 Shown)**

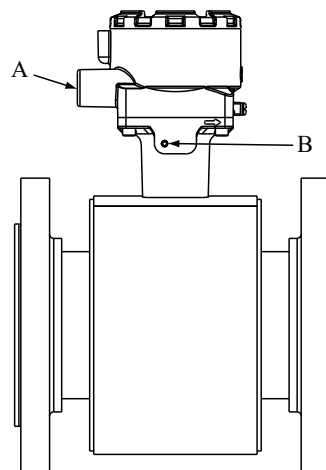

- A. Conduit connection*
- B. No relief port (welded shut or absent)*

### 6.3.2 Process leak protection (option M1)

The sensor is available with process leak detection through the use of a threaded connection and pressure relief valve (PRV). This coil housing configuration is a factory sealed all-welded enclosure. The M1 configuration is available for the 8705 only.

- 8705 with option code M1 - 8705xxxxxxxxM1

A PRV can be installed in the threaded connection to prevent possible over-pressuring of the coil housing caused by a primary seal failure. The PRV is capable of venting fugitive emissions when pressure inside the coil housing exceeds five psi. Additional piping may be connected to the PRV to drain any process leakage to a safe location (see [Figure 6-12](#)).

In the event of a primary seal failure, this configuration will not protect the coils or other internal components of the sensor from exposure to the process fluid.

---

**Note**

The PRV is supplied with the meter to be installed by the customer. Installation of the PRV and any associated piping must be performed in accordance with environmental and hazardous area requirements.

---

**Figure 6-12: Sensor with M1 Coil Housing Configuration and PRV**

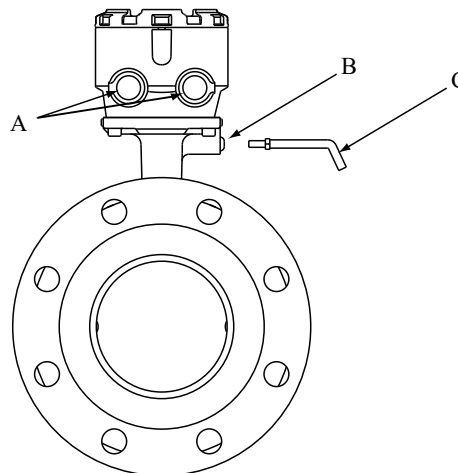

- A. Conduit connection
  - B. M6 threaded pressure relief port with removable cap screw
  - C. Optional: Use relief port to plumb to safe area (supplied by user).
- 

### 6.3.3 Process leak containment (Option M2 or M4)

The sensor is available with process leak containment. The coil housing configuration is a factory sealed all-welded enclosure with the addition of sealed electrode compartments. The M2/M4 configuration is available for the 8705 only.

- 8705 with option code M2/M4 - 8705xxxxxxxxM2/M4

This configuration divides the coil housing into separate compartments, one for each electrode and one for the coils. In the event of a primary seal failure, the fluid is contained in the electrode compartment. The sealed electrode compartment prevents the process fluid from entering the coil compartment where it may damage the coils and other internal components. The electrode compartments are designed to contain the process fluid up to a maximum pressure of 740 psig.

- Code M2 - sealed, welded coil housing with separate sealed and welded electrode compartments (see [Figure 6-13](#)).
- Code M4 - sealed, welded coil housing with separate sealed and welded electrode compartments with a threaded port on the electrode tunnel cap, capable of venting fugitive emissions (see [Figure 6-14](#)).

---

**Note**

To properly vent process fluid from the electrode compartment to a safe location, additional piping is required and must be installed by the user. Installation of any associated piping must be performed in accordance with environmental and hazardous

area requirements. In the event of primary seal failure, the electrode compartment may be pressurized. Use caution when removing the cap screw.

---

**Figure 6-13: Sensor with M2 Coil Housing Configuration**

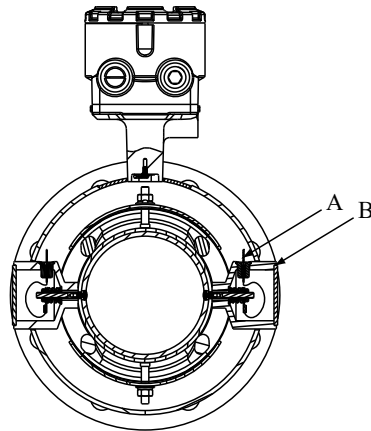

- A. 2x fused glass seal
  - B. 2x sealed electrode compartment
- 

**Figure 6-14: Sensor with M4 Coil Housing Configuration**

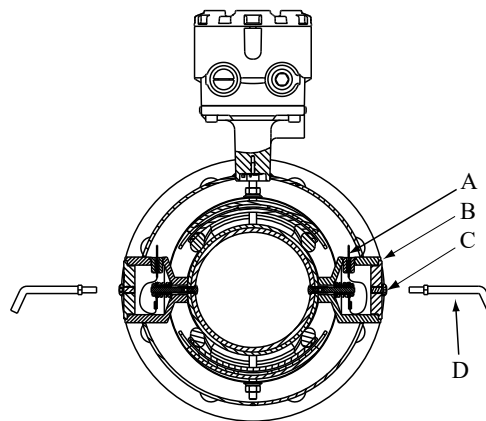

- A. 2x fused glass seal
  - B. 2x sealed electrode compartment
  - C. M6 threaded pressure relief port with removable cap screw
  - D. Optional: Use relief port to plumb to safe area (supplied by user).
-



## 6.3.4 Higher temperature applications and sensor insulation best practices

Insulation of the magnetic flowmeter sensor is not typically recommended. However, in applications with higher temperature process fluids (above 150 °F / 65 °C), plant safety, sensor reliability, and sensor longevity can be improved with careful attention to proper insulation.

### Procedure

1. In applications where process fluid permeation of the liner has been observed or may be expected, the rate of permeation can be reduced by decreasing the temperature gradient between the process fluid and the outside of the meter body. In these applications, only the space between the process flanges and the coil housing should be insulated (see [Figure 6-15](#)).

**Figure 6-15: Insulating a Rosemount Magnetic Flowmeter for Permeation**

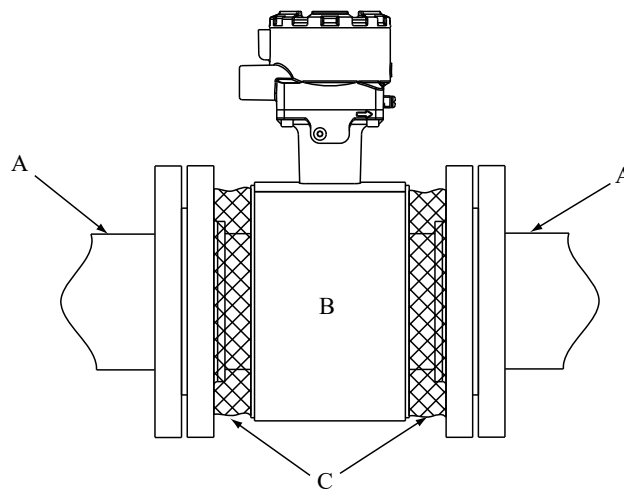

- A. Process piping
- B. Coil housing
- C. Insulation

2. When insulation of the magnetic flowmeter sensor is required due to plant safety standards designed to protect personnel from contact burns, extend the insulation up to the coil housing, covering both ends of the sensor and flanges ([Figure 6-16](#)).

The insulation should NOT cover the coil housing or the terminal junction box. Insulating the coil housing and the terminal junction box can result in overheating of the coil compartment and terminals, resulting in erratic/erroneous flow readings and potential damage or failure of the meter.

---

**Figure 6-16: Insulating a Rosemount Magnetic Flowmeter for Safety/Plant Standards**

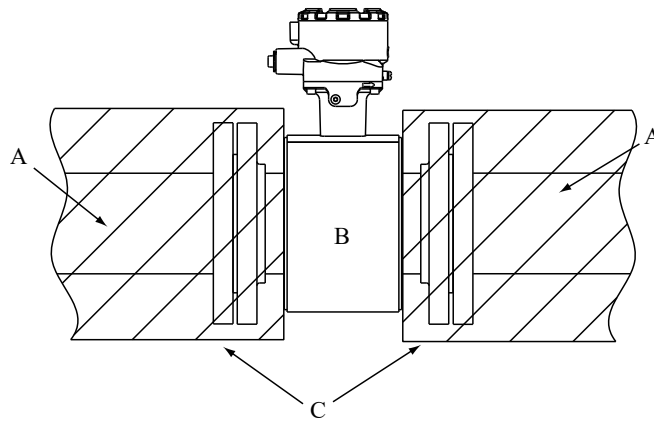

- A. Process piping
  - B. Coil housing
  - C. Insulation
-

# 7 Operation

## 7.1 Introduction

The transmitter features a full range of software functions, transmitter configurations, and diagnostic settings. These features can be accessed through ProLink III configuration software, a Field Communicator, or other FOUNDATION™ Fieldbus host or configuration tool.

The Local Operator Interface (LOI) is a configurable, passive display that can show process variables, status information, and diagnostic messages. Refer to [Advanced Configuration Functionality](#) for information about configuring the LOI.

## 7.2 Local operator interface (LOI)

The optional LOI provides a communications center for the transmitter.

The LOI allows an operator to:

- Change transmitter configuration
- View flow and totalizer values
- Start/stop and reset totalizer values
- Run diagnostics and view the results
- Monitor transmitter status

### 7.2.1 Basic features

The basic features of the LOI include a display window and four navigational arrow keys.

Figure 7-1: Local Operator Interface Keypad and Character Display

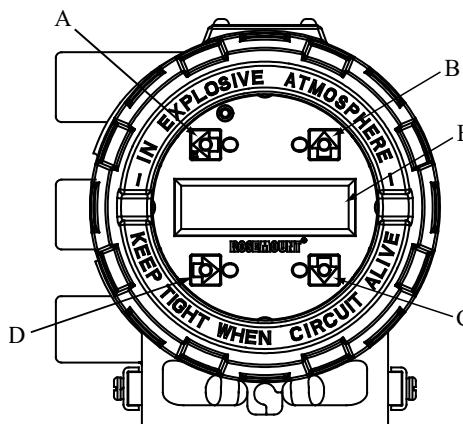

- A. **LEFT** (E) key
- B. **UP** key
- C. **DOWN** key
- D. **RIGHT** key
- E. Display window

To access the LOI, press the DOWN arrow one time. Use the UP, DOWN, LEFT, and RIGHT arrows to navigate the menu structure. A map of the LOI menu structure is shown in [LOI menu tree](#).

## 7.2.2 Data entry

The LOI keypad does not have alphanumeric keys. Alphanumeric and symbolic data is entered by the following procedure. Use the steps below to access the appropriate functions.

### Procedure

1. Use , , , and to navigate the menu ([LOI menu tree](#)) and access the appropriate alphanumeric parameter.
2. Use , or to begin editing the parameter.
  - Press to go back without changing the value.
  - For numerical data, scroll through the digits 0-9, decimal point, and dash.
  - For alphabetical data, scroll through the letters of the alphabet A-Z, digits 0-9, and the symbols ?, &, +, -, \*, /, \$, @, %, and the blank space.
3. Use to highlight each character you want to change and then use and to select the value.

If you go past a character that you wish to change, keep using to wrap around and arrive at the character you want to change.
4. Press when all changes are complete to save the entered values.
5. Press again to navigate back to the menu tree.

## 7.2.3 Data entry examples

Parameter values are classified as *table values* or *select values*.









**Table values** They are available from a predefined list for parameters such as line size or flow units.

**Select values** Integers, floating point numbers, or character strings that are entered one character at a time using the arrow keys for parameters such as PV URV and calibration number.

### Table value example

Setting the sensor size:

#### Procedure











1. Press  key to access the menu. See [LOI menu tree](#).
2. Use , , , and  to select line size from the basic setup menu.
3. Use  or  to increase/decrease the sensor size.
4. When you reach the desired sensor size, press .
5. Set the loop to manual if necessary, and press  again.

After a moment, the LOI will display `VALUE STORED SUCCESSFULLY` and then display the selected value.

### Select value example

Changing the upper range limit:



#### Procedure

1. Press  key to access the menu. See [LOI menu tree](#).
2. Use , , , and  to select **PV URV** from the basic setup menu.
3. Press  to position the cursor.
4. Press  or  to set the number.
5. Repeat [Step 3](#) and [Step 4](#) until desired number is displayed, press .
6. Set the loop to manual if necessary, and press  again.

After a moment, the LOI will display `VALUE STORED SUCCESSFULLY` and then display the selected value.

## 7.2.4 Dynamic variable display pause

To make dynamically changing variables easier to read and record, a pause feature has been built into the LOI.

When viewing a dynamic variable (such as a totalizer value) from the view variable screen, press  to pause the display value. To return the screen to the dynamic display mode, press  again, or exit the screen by pressing .

---

#### Note

It is important to note this feature pauses only the display. While the display is paused, the transmitter continues to measure all variables dynamically, and continues to increment the totalizer.

---

## 7.2.5 Totalizer functionality

### Totalizer selection

#### Procedure

- To view the totalizer values, first press  to access the LOI menu structure. The first option is the totalizers. Under this section, you can view and configure the totalizers.

See [Totalizer](#) for more information on the totalizer functionality.

### Start all / Stop all

Totalizers can be started or stopped simultaneously. See [Totalizer](#). They cannot be started and stopped individually.

### Reset totalizer

The totalizers can be configured to be reset through the LOI. They can be reset individually, or simultaneously through a global command. For details on configuring the reset functionality and on resetting the totalizers, refer to [Totalizer](#).

## 7.2.6 Display lock

The transmitter has display lock functionality to prevent unintentional configuration changes. The display can be locked manually or configured to automatically lock after a set period of time. When locked, the LOI will display the flow screen.







### Manual display lock

To activate, hold the UP arrow for 3 seconds and follow the on-screen instructions. When the display lock is activated, a lock symbol will appear in the lower right hand corner of the display. To deactivate, hold the UP arrow for 3 seconds and follow the on-screen instructions. When the display lock is deactivated, the lock symbol will no longer appear in the lower right hand corner of the display.

### Auto display lock

The transmitter can be configured to automatically lock the LOI. Follow the instructions below to access configuration.

#### Procedure

1. Press  to access the menu. See [LOI menu tree](#).
2. Scroll to and select **LOI Config** from the Detailed Setup menu.
3. Press  to highlight **Disp Auto Lock** and press  to enter the menu.
4. Press  or  to select the auto lock time.
5. When you reach the desired time, press .
6. Set the loop to manual if necessary, and press .

After a moment, the LOI will display `VALUE STORED SUCCESSFULLY` and then display the selected value.

## 7.2.7 Diagnostic messages

Diagnostic messages may appear on the LOI. See [Advanced Diagnostics Configuration](#) for a complete list of messages, potential causes, and corrective actions for these messages.

## 7.2.8 Display symbols

When certain transmitter functions are active, a symbol will appear in the lower-right corner of the display. The possible symbols include the following:





Display Lock	
Totalizer	
Reverse flow	
Continuous meter verification	





Figure 7-3: Diagnostics menu map

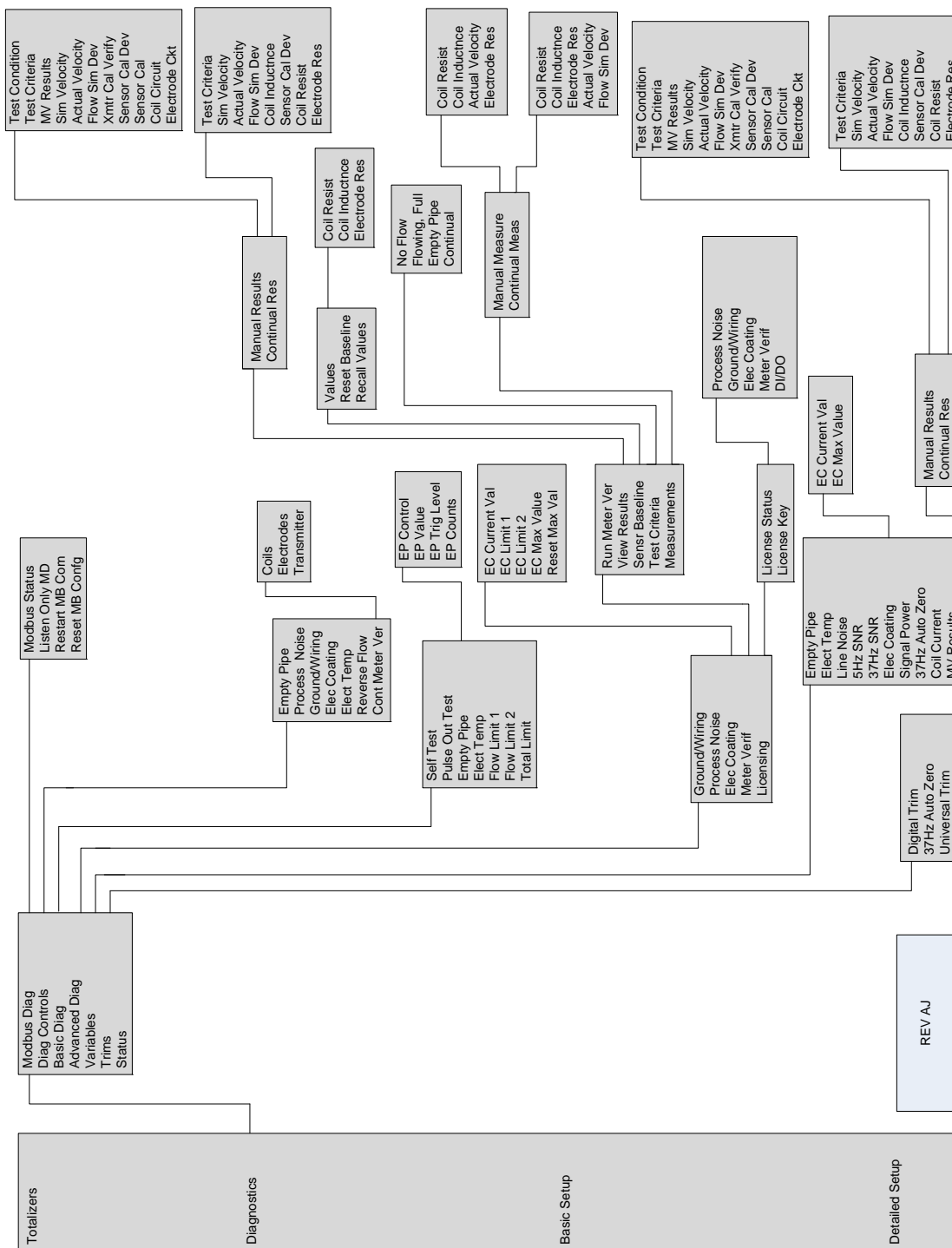

Figure 7-4: Basic setup menu map

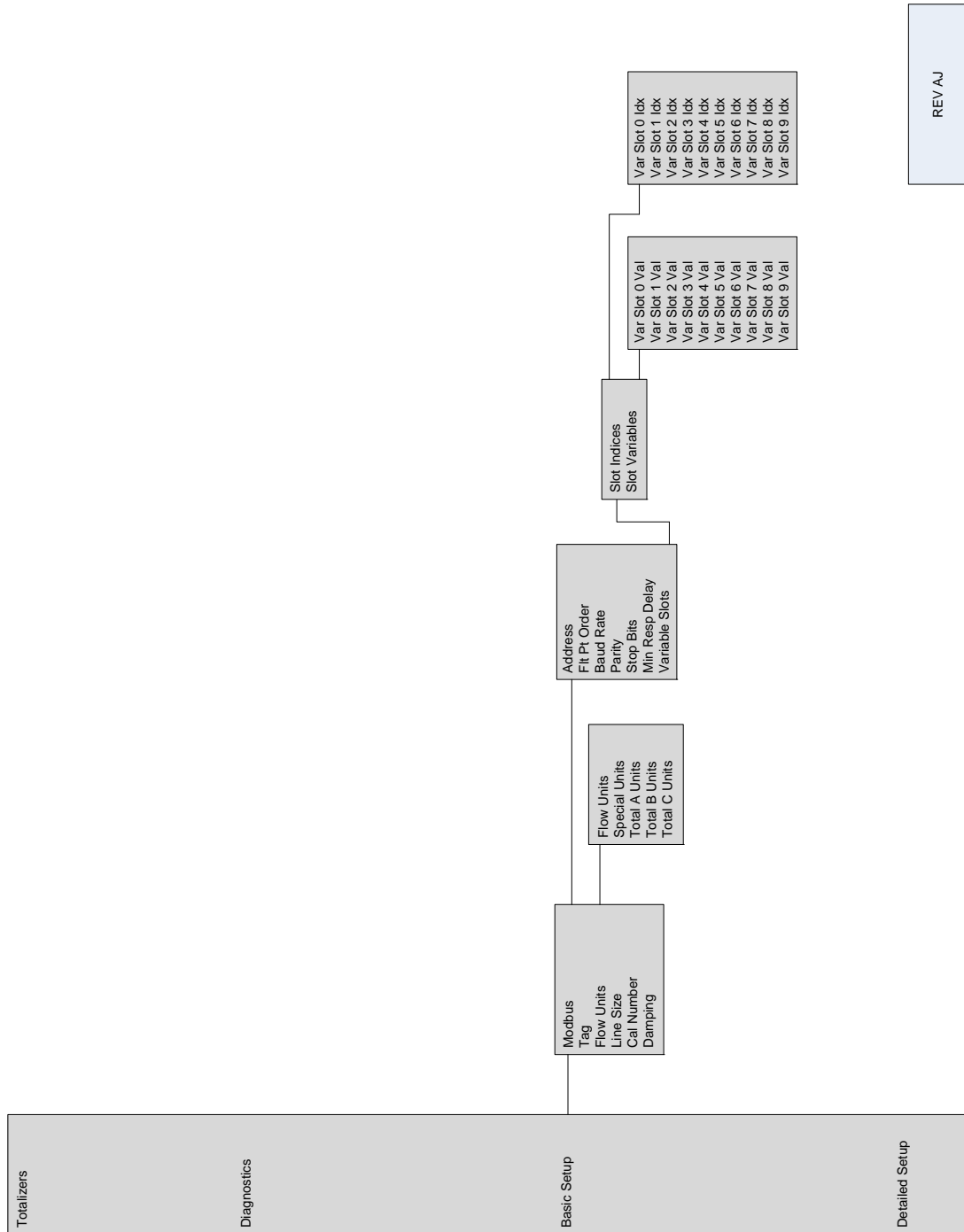
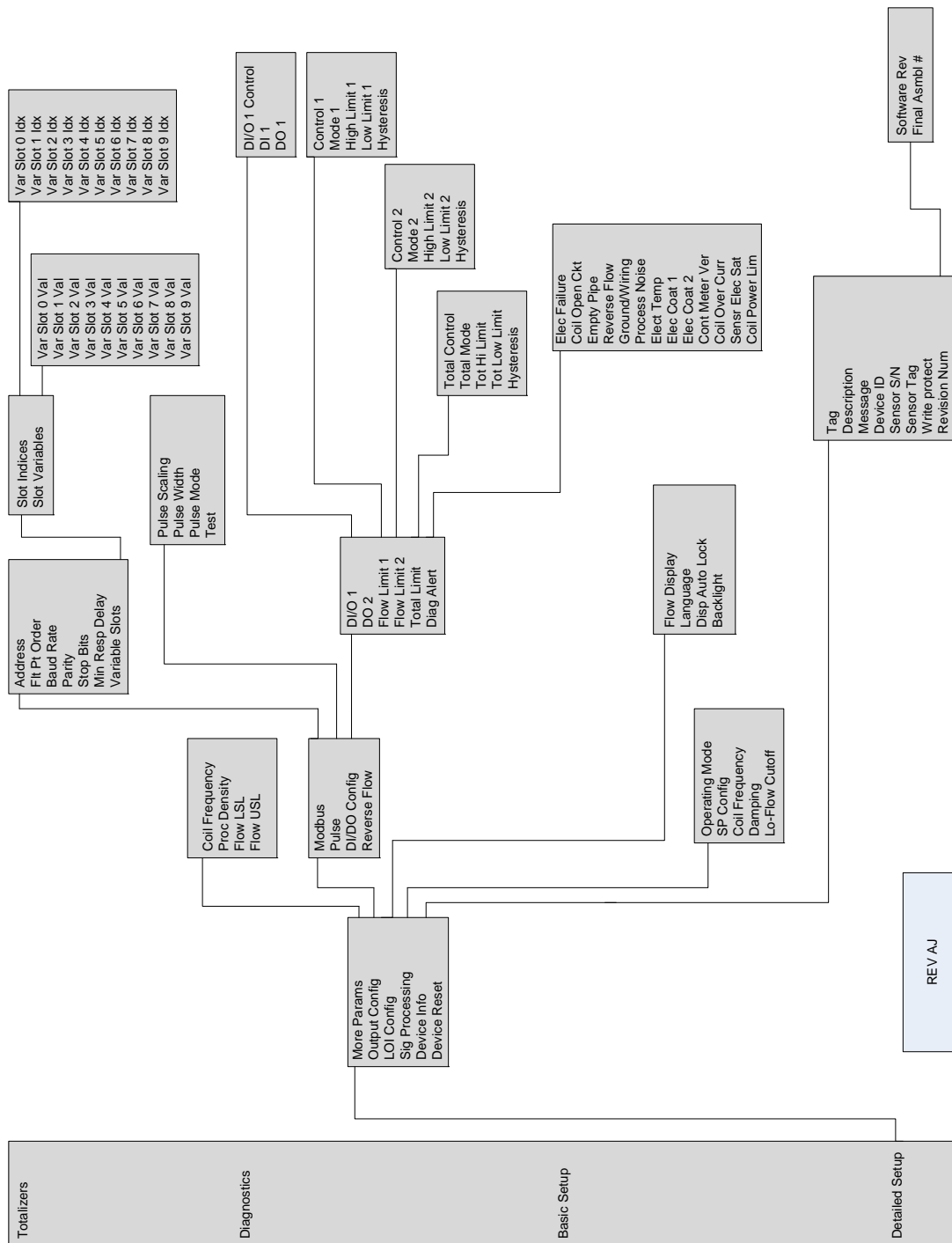

Figure 7-5: Detailed setup menu map





# 8 Advanced Configuration Functionality

## 8.1 Introduction

This section contains information for advanced configuration parameters.

The software configuration settings for the transmitter can be accessed through the Local Operator Interface (LOI) or a modbus host. Before operating the transmitter in an actual installation, you should review all of the factory set configuration data to ensure that they reflect the current application.

## 8.2 Configure outputs

LOI menu path	<b>Detailed Setup</b> → <b>Output Config</b>
---------------	--

The configure outputs functionality is used to configure advanced features that control the Modbus, pulse, auxiliary, and totalizer outputs of the transmitter.

### 8.2.1 Modbus output

Configure the Modbus communication parameters.

#### Address

LOI menu path	<b>Detailed Setup</b> → <b>Output Config</b> → <b>Modbus</b> → <b>Address</b>
Modbus register	109

Configure the address of the transmitter for the Modbus network. The acceptable range is an integer value from 1 to 247. The default address is 1.

Each register is identified by its address (or starting address). Depending on the PLC that will be used to communicate with the transmitter, you may need to subtract 1 from the address, or starting address, of the register. Refer to PLC documentation to determine if this applies.

#### Floating point byte order

LOI menu path	<b>Detailed Setup</b> → <b>Output Config</b> → <b>Modbus</b> → <b>Flt Pt Order</b>
Modbus register	110

Sets the order that information is sent by the transmitter.

Register value	Byte order
0	0-1-2-3 (default)
1	2-3-0-1
2	1-0-3-2
3	3-2-1-0

### Baud rate

LOI menu path	<b>Detailed Setup → Output Config → Modbus → Baud Rate</b>
Modbus register	115

Sets the communication speed of the transmitter.

Register value	Baud rate
0	1200
1	2400
2	4800
3	9600
4	19200 (default)
5	38400
6	57600
7	115200

### Parity

LOI menu path	<b>Detailed Setup → Output Config → Modbus → Parity</b>
Modbus register	116

Used to configure error-checking methodology for the data.

Register value	Parity
0	No parity
1	Odd
2	Even (default)

### Stop bits

LOI menu path	<b>Detailed Setup → Output Config → Modbus → Stop Bits</b>
Modbus register	117

Sets the last bit of the data packet.

Register value	Stop bits
1	1 bit (default)
2	2 bits

### Minimum response delay

LOI menu path	<b>Detailed Setup → Output Config → Modbus → Min Resp Delay</b>
Modbus register	111

*Minimum response delay* is used to synchronize Modbus communications with hosts that operate at a slower speed than the transmitter. The value specified here will be the

minimum elapsed time before the transmitter sends a response to the host. This value can be configured as an integer from 0 to 250 ms. The default value is 10 ms.

**Note**

Do not set the minimum response delay unless required by the Modbus host.

**Variable slots**

LOI menu path	<b>Detailed Setup → Output Config → Modbus → Variable Slots</b>
---------------	---

*Variable slots* allows for the customization of variables into fixed Modbus register locations. Up to 30 slots can be configured using ProLink III or a Modbus configuration tool. Through the LOI, configuration functionality is limited to 10 slots.

**Slot indices**

LOI menu path	<b>Detailed Setup → Output Config → Modbus → Slot Indices</b>
Modbus register	651–680

Assign variables to the various Modbus slots for easy reference. Slots 0 through 9 can be configured through the LOI, ProLink III, or a Modbus configuration tool. Slots 10 through 29 can only be configured through ProLink III or a Modbus configuration tool.

Slot variables can be assigned to the slots.

Register value	Variable
0	Flow rate
1	Pulse output frequency
2	Totalizer A
3	Totalizer B
4	Totalizer C
5	Electronics temperature
6	Line noise
7	5 Hz signal to noise ratio
8	37 Hz signal to noise ratio
9	Signal power
10	Empty pipe value
11	Continuous internal flow simulator test deviation
12	Electrode coating value
13	Continuous electrode resistance value
14	Continuous coil resistance value
15	Continuous coil inductance value
16	Continuous coil inductance deviation value

**Slot variables**

LOI menu path	<b>Detailed Setup → Output Config → Modbus → Variable Slots → Slot Variables</b>
Modbus register	691–749

View the variable values indexed to slots 0 through 9 on the LOI. Slots 10 through 29 can only be viewed through ProLink III or a Modbus configuration tool. These are read-only variables.

## 8.2.2 Pulse output

LOI menu path	<b>Detailed Setup → Output Config → Pulse</b>
---------------	---

Under this function the pulse output of the transmitter can be configured.

### Pulse scaling

LOI menu path	<b>Detailed Setup → Output Config → Pulse → Pulse Scaling</b>
Modbus register	327-328

Transmitter may be commanded to supply a specified frequency between 1 pulse/ day at 39.37 ft/sec (12 m/s) to 5000 Hz at 1 ft/sec (0.3 m/s).

#### Note

The maximum pulse scaling frequency for transmitters with an intrinsically safe output is 5000 Hz.

#### Note

Line size, special units, and density must be selected prior to configuration of the pulse scaling factor.

The pulse output scaling equates one transistor switch closure pulse to a selectable number of volume units. The volume unit used for scaling pulse output is taken from the numerator of the configured flow units. For example, if gal/min had been chosen when selecting the flow unit, the volume unit displayed would be gallons.

#### Note

The pulse output scaling is designed to operate between 0 and 5000 Hz. The minimum conversion factor value is found by dividing the minimum span (in units of volume per second) by 5000 Hz.

When selecting pulse output scaling, the maximum pulse rate is 5000 Hz. With the 10 percent over range capability, the absolute limit is 5500 Hz. For example, if you want the transmitter to pulse every time 0.01 gallons pass through the sensor, and the flow rate is 5000 gal/min, you will exceed the 5000 Hz full-scale limit:

$$\frac{5000 \text{ gal}}{1 \text{ min}} \times \frac{1 \text{ min}}{(60 \text{ sec})} \times \frac{1 \text{ pulse}}{0.01 \text{ gal}} = 8,333.3 \text{ Hz}$$

The best choice for this parameter depends upon the required resolution, the number of digits in the totalizer, the extent of range required, and the maximum frequency limit of the external counter.

### Pulse factor units

LOI menu path	<b>Detailed Setup → Output Config → Pulse → Units</b>
Modbus register	37

The pulse factor unit assigns the unit of measure to the pulse scaling factor. The default read-only value is the unit of measure from the configured flow units. For example, if gal/min is selected when configuring the flow units, the pulse factor unit will be gallons.



**Table 8-1: Pulse factor volume units**

Register value	Units
40	Gallons
41	Liters
42	Imperial gallons
43	Cubic meters
46	Barrels (42 gallons)
112	Cubic feet
246	Cubic centimeters
247	Barrels (31 gallons)
249	Millions gallons

**Table 8-2: Pulse factor mass units**

Register value	Units
61	Kilograms
62	Metric tons
63	Pounds
64	Short tons

**Table 8-3: Pulse factor other units**

Register value	Units
44	Feet
45	Meters
253	Special units <sup>(1)</sup>

(1) See *Configure special units*.

**Pulse width**

LOI menu path	<b>Detailed Setup → Output Config → Pulse → Pulse Width</b>
Modbus register	329, 330

The factory default pulse width is 0.5 ms.

The width, or duration, of the pulse can be adjusted to match the requirements of different counters or controllers (see [Figure 8-1](#)). These are typically lower frequency applications (< 1000 Hz). The transmitter will accept values from 0.1 ms to 650 ms.

For frequencies higher than 1000 Hz, it is recommended to set the pulse mode to 50% duty cycle by setting the pulse mode to frequency output.

The pulse width will limit the maximum frequency output, If the pulse width is set too wide (more than ½ the period of the pulse) the transmitter will limit the pulse output. See example below.

**Figure 8-1: Pulse Output**

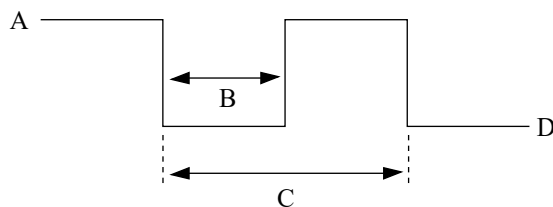

- A. Open
- B. Pulse width
- C. Period
- D. Closed

**Example**

If pulse width is set to 100 ms, the maximum output is 5 Hz; for a pulse width of 0.5 ms, the maximum output would be 1000 Hz (at the maximum frequency output there is a 50% duty cycle).

Pulse width	Minimum period (50% duty cycle)	Maximum frequency
100 ms	200 ms	$\frac{1 \text{ cycle}}{200 \text{ ms}} = 5 \text{ Hz}$
0.5 ms	1.0 ms	$\frac{1 \text{ cycle}}{1.0 \text{ ms}} = 1000 \text{ Hz}$

To achieve the greatest maximum frequency output, set the pulse width to the lowest value that is consistent with the requirements of the pulse output power source, pulse driven external totalizer, or other peripheral equipment.

The maximum flow rate is 10,000 gpm. Set the pulse output scaling such that the transmitter outputs 5000 Hz at 10,000 gpm.

$$\text{Pulse Scaling} = \frac{\text{Flow Rate (gpm)}}{(60 \frac{\text{sec}}{\text{min}}) \times (\text{frequency})}$$

$$\text{Pulse Scaling} = \frac{10,000 \text{ gpm}}{(60 \frac{\text{sec}}{\text{min}}) \times (5000 \text{ Hz})}$$

$$\text{Pulse Scaling} = 0.0333 \frac{\text{gal}}{\text{pulse}}$$

$$1 \text{ pulse} = 0.0333 \text{ gal}$$

**Note**

Changes to pulse width are only required when there is a minimum pulse width required for external counters, relays, etc.

The external counter is ranged for 350 gpm and pulse is set for one gallon. Assuming the pulse width is 0.5 ms, the maximum frequency output is 5.833 Hz.

$$\text{Frequency} = \frac{\text{Flow Rate (gpm)}}{\left(60 \frac{\text{sec}}{\text{min}}\right) \times \left(\text{pulse scaling} \frac{\text{gal}}{\text{pulse}}\right)}$$

$$\text{Pulse Scaling} = \frac{350 \text{ gpm}}{\left(60 \frac{\text{sec}}{\text{min}}\right) \times 1 \frac{\text{gal}}{\text{pulse}}}$$

$$\text{Frequency} = 5.833 \text{ Hz}$$

The upper range value (20 mA) is 3000 gpm. To obtain the highest resolution of the pulse output, 5000 Hz is scaled to the full scale analog reading.

$$\text{Frequency} = \frac{\text{Flow Rate (gpm)}}{\left(60 \frac{\text{sec}}{\text{min}}\right) \times \left(\text{pulse scaling} \frac{\text{gal}}{\text{pulse}}\right)}$$

$$\text{Pulse Scaling} = \frac{3,000 \text{ gpm}}{\left(60 \frac{\text{sec}}{\text{min}}\right) \times 5000 \text{ Hz}}$$

$$\text{Pulse Scaling} = 0.01 \frac{\text{gal}}{\text{pulse}}$$

$$1 \text{ pulse} = 0.01 \text{ gal}$$

### Pulse mode

LOI menu path	<b>Detailed Setup</b> → <b>Output Config</b> → <b>Pulse</b> → <b>Pulse Mode</b>
Modbus register	85

The pulse mode configures the frequency output of the pulse. It can be set to either 50% duty cycle, or fixed. There are two options that pulse mode can be configured to:

- Pulse Output (user defines a fixed pulse width)
- Frequency Output (pulse width automatically set to 50% duty cycle)

Register value	Mode
0	Pulse Output: User defines a fixed pulse width (default)
1	Frequency Output: Pulse width automatically set to 50% duty cycle

To use pulse width settings, pulse mode must be set to pulse output.

## 8.2.3 Totalizer

The totalizer provides the total amount of fluid that has passed through the meter. There are three available totalizers: Total A, Total B, and Total C. They can be independently configured for one of the following options:

- Net - increments with forward flow and decrements with reverse flow (reverse flow must be enabled).
- Reverse total - will only increment with reverse flow if reverse flow is enabled
- Forward total - will only increment with forward flow

All totalizer values will be reset if **line size** is changed. This will happen even if the totalizer reset control is set to **non-resettable**.

The totalizers have the capability to increment the total to a maximum value of 50 feet per second of flow (or the volumetric equivalent) for a period of 20 years before roll-over occurs.

### View Totals

LOI menu path	Totalizer A: <b>Totalizers</b> → <b>View Total A</b> Totalizer B: <b>Totalizers</b> → <b>View Total B</b> Totalizer C: <b>Totalizers</b> → <b>View Total C</b>
Modbus registers	Totalizer A: 203, 204 Totalizer B: 205, 206 Totalizer C: 207, 208

Displays the current value for each totalizer and shows the totalizer incrementing/decrementing based on totalizer configuration and flow direction.

### Configure totalizers

LOI menu path	<b>Totalizers</b> → <b>Config/Control</b>
Modbus registers	101, 103

### Start, stop, reset all totalizers

Modbus registers	See below.
------------------	------------

Totalizer funtion	Modbus coil	Modbus coil value
Start all totalizers	101	1
Stop all totalizers	101	0
Reset all totalizers	103	1

#### Note

If an individual totalizer is configured as non-resettable, reset all totalizers will **not** affect that totalizer.

#### Note

If an individual totalizer is configured as write protected, the global totalizer start/stop/reset commands will **not** affect that totalizer.

### Totalizer direction

LOI menu path	Totalizer A: <b>Totalizers</b> → <b>Config/Control</b> → <b>Total A</b> → <b>Total A Config</b> → <b>Direction</b> Totalizer B: <b>Totalizers</b> → <b>Config/Control</b> → <b>Total B</b> → <b>Total B Config</b> → <b>Direction</b> Totalizer C: <b>Totalizers</b> → <b>Config/Control</b> → <b>Total C</b> → <b>Total C Config</b> → <b>Direction</b>
Modbus register	Totalizer A: 101 Totalizer B: 103 Totalizer C: 105

Configure the direction for the totalizers as either Net, Forward, or Reverse.

Register value	Totalizer direction
0	Net (default for Total A)
1	Forward (default for Total B)
2	Reverse (default for Total C)

### Totalizer units

LOI menu path	Totalizer A: <b>Totalizers</b> → <b>Config/Control</b> → <b>Total A</b> → <b>Total A Config</b> → <b>TotA Units</b> Totalizer B: <b>Totalizers</b> → <b>Config/Control</b> → <b>Total B</b> → <b>Total B Config</b> → <b>TotB Units</b> Totalizer C: <b>Totalizers</b> → <b>Config/Control</b> → <b>Total C</b> → <b>Total C Config</b> → <b>TotC Units</b>
Modbus register	Totalizer A: 62 Totalizer B: 63 Totalizer C: 64

Configure the units for totalizers.

**Table 8-4: Totalizer units**

Volume units		Mass units		Other units	
LOI	Units	LOI	Units	LOI	Units
gal	Gallons	KG	Kilograms	ft	Feet
l	Liters	Mton	Metric tons	m	Meters
Igal	Imperial gallons	lb	Pounds	Special	Special Units <sup>(1)</sup>
m3	Cubic meters	Ston	Short tons		
B42	Barrels (42 gallons)				
ft3	Cubic feet				
cm3	Cubic centimeters				
B31	Barrels (31 gallons)				
Mgal	Million gallons				

(1) See *Configure special units*.

**Table 8-5: Totalizer volume units**

Register value	Units
40	Gallons
41	Liters
42	Imperial gallons
43	Cubic meters
46	Barrels (42 gallons)
112	Cubic feet
246	Cubic centimeters
247	Barrels (31 gallons)

**Table 8-6: Totalizer mass units**

Register value	Units
61	Kilograms

**Table 8-6: Totalizer mass units (continued)**

Register value	Units
62	Metric tons
63	Pounds
64	Short tons

**Table 8-7: Totalizer other units**

Register value	Units
44	Feet (default)
45	Meters
253	Special units (see <a href="#">Configure special units.</a> )

### Reset configuration

LOI menu path	Totalizer A: <b>Totalizers</b> → <b>Config/Control</b> → <b>Total A</b> → <b>Total A Config</b> → <b>TotA Reset Config</b> Totalizer B: <b>Totalizers</b> → <b>Config/Control</b> → <b>Total B</b> → <b>Total B Config</b> → <b>TotB Reset Config</b> Totalizer C: <b>Totalizers</b> → <b>Config/Control</b> → <b>Total C</b> → <b>Total C Config</b> → <b>TotC Reset Config</b>
Modbus register	Totalizer A: 100 Totalizer B: 102 Totalizer C: 104

Configure if the totalizer is non-resettable, or if it can be reset through the reset commands.

Register value	Reset options
0	Not resettable (default for Totalizer B & C)
1	Resettable (default for Totalizer A)

### Reset individual totalizer

LOI menu path	Totalizer A: <b>Totalizers</b> → <b>Config/Control</b> → <b>Total A</b> → <b>Reset Total A</b> Totalizer B: <b>Totalizers</b> → <b>Config/Control</b> → <b>Total B</b> → <b>Reset Total B</b> Totalizer C: <b>Totalizers</b> → <b>Config/Control</b> → <b>Total C</b> → <b>Reset Total C</b>
Modbus coil	Totalizer A: 104 Totalizer B: 105 Totalizer C: 106

Independently reset the totalizers. This requires the reset option to be configured as resettable.

Register value	Reset options
0	Run
1	Reset

### Totalizer security

LOI menu path	<b>Totalizers → Config/Control → Security</b>
---------------	---

Configure totalizer security capabilities for the Local Operator Interface and write protection.

### LOI control

LOI menu path	<b>Totalizers → Config/Control → Security → LOI Control</b>
---------------	---

Configure the ability to start, stop, and reset the totalizers through the LOI.

### LOI totalizer start/stop

LOI menu path	<b>Totalizers → Config/Control → Security → LOI Control → LOI Start/Stop</b>
Modbus coil	141

Enable/disable the ability to start or stop totalizers through the LOI.

Modbus coil value	Operating mode
0	Prevent totalizer reset through the LOI
1	Allow totalizer reset through the LOI (default)

### LOI totalizer reset

LOI menu path	<b>Totalizers → Config/Control → Security → LOI Control → LOI Reset</b>
---------------	---

Enable/disable the ability to reset the totalizers through the LOI.

### Totalizer write protection

LOI menu path	<b>Totalizers → Config/Control → Security → Write Protect</b>
---------------	---

In addition to controlling the LOI capability to start/stop and reset the totalizers, specific write protect functionality can also be configured adding an additional level of security to the totalizers.

### Start/stop write protect

LOI menu path	<b>Totalizers → Config/Control → Security → Write Protect → WP Start/Stop</b>
Modbus coil	139

Configure write protection on the ability to start or stop the totalizers. This is a global command and applies to all totalizers.

Register value	Reset options
0	Disable totalizer start/stop write protect (default)
1	Enable totalizer start/stop write protect



### Reset write protect

LOI menu path	<b>Totalizers → Config/Control → Security → Write Protect → WP Reset</b>
Modbus coil	140

Configure write protection on the ability to reset the totalizers. This is a global command and applies to all totalizers.

Register value	Reset options
0	Disable totalizer reset write protect (default)
1	Enable totalizer reset write protect

## 8.2.4 Discrete input/output

This configuration option is only available if the auxiliary output suite (option code AX) was ordered. The auxiliary output suite provides two channels for control.

- The discrete input can provide Positive Zero Return (PZR) and net totalizer reset.
- The discrete output control function can be configured to drive an external signal to indicate zero flow, reverse flow, empty pipe, diagnostic status, flow limit, or transmitter status.

A complete list and description of the available auxiliary functions is provided below.

### Discrete input options (Channel 1 only)

<b>PZR (Positive Zero Return)</b>	When conditions are met to activate the input, the transmitter will force the output to zero flow.
<b>Net Total Reset</b>	When conditions are met to activate the input, the transmitter will reset the net total value to zero.

### Discrete output options

<b>Reverse Flow</b>	The output will activate when the transmitter detects a reverse flow condition.
<b>Zero Flow</b>	The output will activate when a no flow condition is detected.
<b>Transmitter Fault</b>	The output will activate when a transmitter fault condition is detected.
<b>Empty Pipe</b>	The output will activate when the transmitter detects an empty pipe condition.
<b>Flow Limit 1</b>	The output will activate when the transmitter measures a flow rate that meets the conditions established for the flow limit 1 alert.
<b>Flow Limit 2</b>	The output will activate when the transmitter measures a flow rate that meets the conditions established for the flow limit 2 alert.
<b>Diagnostic Status Alert</b>	The output will activate when the transmitter detects a condition that meets the configured criteria of the diagnostic status alert.
<b>Total Limit</b>	The output will activate when the transmitter Totalizer A value meets the conditions established for the total limit alert.

### Channel 1

Channel 1 can be configured as either a discrete input (DI) or as a discrete output (DO).

#### DI/O 1 control

LOI menu path	<b>Detailed Setup</b> → <b>Output Config</b> → <b>DI/DO Config</b> → <b>DI/O 1</b> → <b>DI/O 1 Control</b>
Modbus register	91

This parameter configures the auxiliary output channel 1. It controls whether channel 1 will be a discrete input or discrete output on terminals 5 (-) and 6 (+).

#### Note

The transmitter must have been ordered with the auxiliary output suite (option code AX) to have access to this functionality.

Register value	Operating mode
1	Input (default)
2	Output
251	Not available

#### Discrete input 1

LOI menu path	<b>Detailed Setup</b> → <b>Output Config</b> → <b>DI/DO Config</b> → <b>DI/O 1</b> → <b>DI 1</b>
Modbus register	92

This parameter displays the configuration for channel 1 when used as a discrete input.

Register value	Configuration
0	PZR (default)
1	Totalizer A reset
2	Totalizer B reset
3	Totalizer C reset
251	Not available

### Discrete output 1

LOI menu path	<b>Detailed Setup</b> → <b>Output Config</b> → <b>DI/DO Config</b> → <b>DI/O 1</b> → <b>DO 1</b>
Modbus register	93

This parameter displays the configuration for channel 1 when used as a discrete output.

Register value	Configuration
0	Reverse flow
1	Zero flow (default)
2	Transmitter fault
3	Empty pipe
4	Flow limit 1
5	Flow limit 2
6	Diagnostic status alert
7	Totalizer limit 1
251	Reset all

### Channel 2

Channel 2 is available as discrete output only.

#### Discrete output 2

LOI menu path	<b>Detailed Setup</b> → <b>Output Config</b> → <b>DI/DO Config</b> → <b>DO 2</b>
Modbus register	96

This parameter displays the configuration for channel 2.

Register value	Configuration
0	Reverse flow
1	Zero flow (default)
2	Transmitter fault
3	Empty pipe
4	Flow limit 1
5	Flow limit 2
6	Diagnostic status alert
7	Totalizer limit 1
251	Reset all

### Flow limit (1 and 2)

There are two configurable flow limits. Configure the parameters that will determine the criteria for activation of a diagnostic alert if the measured flow rate falls within a set of configured criteria. This functionality can be used for operating simple batching operations or generating alerts when certain flow conditions are met. This parameter can be configured as a discrete output if the transmitter was ordered with the auxiliary output suite (option code AX) and the outputs are enabled. If a discrete output is configured for flow limit, the discrete output will activate when the conditions defined under mode configuration are met. See [Mode](#) below.

### Control

LOI menu path	Flow 1: <b>Detailed Setup</b> → <b>Output Config</b> → <b>DI/DO Config</b> → <b>Flow Limit 1</b> → <b>Control 1</b> Flow 2: <b>Detailed Setup</b> → <b>Output Config</b> → <b>DI/DO Config</b> → <b>Flow Limit 2</b> → <b>Control 2</b>
Modbus coil	Flow limit 1: 97 Flow limit 2: 98

This parameter turns the flow limit diagnostic alert ON or OFF.

**ON** The transmitter will generate a diagnostic alert when the defined conditions are met. If a discrete output is configured for flow limit, the discrete output will activate when the conditions for mode are met.

**OFF** The transmitter will not generate an alert for the flow limit.

Modbus coil value	Configuration
0	Off (default)
1	On

### Mode

LOI menu path	Flow 1: <b>Detailed Setup</b> → <b>Output Config</b> → <b>DI/DO Config</b> → <b>Flow Limit 1</b> → <b>Mode 1</b> Flow 2: <b>Detailed Setup</b> → <b>Output Config</b> → <b>DI/DO Config</b> → <b>Flow Limit 2</b> → <b>Mode 2</b>
Modbus register	Flow limit 1: 97 Flow limit 2: 98

The mode parameter sets the conditions under which the flow limit diagnostic alert will activate. High and low limits exist for each channel and can be configured independently.

Register value	Configuration	Description
0	High limit	The alert will activate when the measured flow rate exceeds the high limit set point (default).
1	Low limit	The alert will activate when the measured flow rate falls below the low limit set point.
2	In range	The alert will activate when the measured flow rate is between the high limit and low limit set points.
3	Out of range	The alert will activate when the measured flow rate exceeds the high limit set point or falls below the low limit set point.

### High limit

LOI menu path	Flow 1: <b>Detailed Setup</b> → <b>Output Config</b> → <b>DI/DO Config</b> → <b>Flow Limit 1</b> → <b>High Limit 1</b> Flow 2: <b>Detailed Setup</b> → <b>Output Config</b> → <b>DI/DO Config</b> → <b>Flow Limit 2</b> → <b>High Limit 2</b>
Modbus register	Flow limit 1: 337, 338 Flow limit 2: 341, 342

Set the flow rate value that corresponds to the high limit set point for the flow limit alert.

### Low limit

LOI menu path	Flow 1: <b>Detailed Setup</b> → <b>Output Config</b> → <b>DI/DO Config</b> → <b>Flow Limit 1</b> → <b>Low Limit 1</b> Flow 2: <b>Detailed Setup</b> → <b>Output Config</b> → <b>DI/DO Config</b> → <b>Flow Limit 2</b> → <b>Low Limit 2</b>
Modbus register	Flow limit 1: 339, 340 Flow limit 2: 343, 344

Set the flow rate value that corresponds to the low limit set point for the flow limit alert.

### Flow limit hysteresis

LOI menu path	Flow 1: <b>Detailed Setup</b> → <b>Output Config</b> → <b>DI/DO Config</b> → <b>Flow Limit 1</b> → <b>Hysteresis</b> Flow 2: <b>Detailed Setup</b> → <b>Output Config</b> → <b>DI/DO Config</b> → <b>Flow Limit 2</b> → <b>Hysteresis</b>
Modbus register	345, 346

Set the hysteresis band for the flow limit to determine how quickly the transmitter comes out of alert status. The hysteresis value is used for both flow limit 1 and flow limit 2. Changing this parameter under the configuration parameters for one channel will cause it to also change in the other channel.

### Total limit

Configure the parameters that will determine the criteria for activating a diagnostic alert if Totalizer A falls within a set of configured criteria. This functionality can be used for operating simple batching operations or generating alerts when certain localized values are met. This parameter can be configured as a discrete output if the transmitter was ordered with auxiliary outputs enabled (option code AX). If a digital output is configured for total limit, the digital output will activate when the conditions for total mode are met.

### Total control

LOI menu path	<b>Detailed Setup</b> → <b>Output Config</b> → <b>DI/DO Config</b> → <b>Total Limit</b> → <b>Total Control</b>
Modbus coil	107

This parameter turns the total limit diagnostic alert ON or OFF.

Modbus coil value	Configuration	Description
0	Off	The transmitter will not generate an alert for the total limit (default).
1	On	The transmitter will generate a diagnostic alert when the defined conditions are met.

### Total mode

LOI menu path	<b>Detailed Setup</b> → <b>Output Config</b> → <b>DI/DO Config</b> → <b>Total Limit</b> → <b>Total Mode</b>
Modbus register	99

The total mode parameter sets the conditions under which the total limit diagnostic alert will activate. High and low limits exist for each channel and can be configured independently.

Register value	Configuration	Description
0	High limit	The alert will activate when the totalizer A value exceeds the high limit set point (default).
1	Low limit	The alert will activate when the totalizer A value falls below the low limit set point.
2	In range	The alert will activate when the totalizer A value is between the high limit and low limit set points.
3	Out of range	The alert will activate when the totalizer A value exceeds the high limit set point or falls below the low limit set point.

### Total high limit

LOI menu path	<b>Detailed Setup</b> → <b>Output Config</b> → <b>DI/DO Config</b> → <b>Total Limit</b> → <b>Tot Hi Limit</b>
Modbus register	347, 348

Set Totalizer A to a value that corresponds to the high limit set point for the total high limit alert.

### Total low limit

LOI menu path	<b>Detailed Setup</b> → <b>Output Config</b> → <b>DI/DO Config</b> → <b>Total Limit</b> → <b>Tot Low Limit</b>
Modbus register	349, 350

Set the net total value that corresponds to the low limit set point for the total low limit alert.

### Total limit hysteresis

LOI menu path	<b>Detailed Setup</b> → <b>Output Config</b> → <b>DI/DO Config</b> → <b>Total Limit</b> → <b>Hysteresis</b>
Modbus register	351, 352

Set the hysteresis band for the total limit to determine how quickly the transmitter comes out of alert status.

### Diagnostic status alert

LOI menu path	<b>Detailed Setup</b> → <b>Output Config</b> → <b>DI/DO Config</b> → <b>Diag Alert</b>
Modbus coil	See below.

The diagnostic status alert is used to turn on or off the diagnostics that will cause the digital output to activate when configured for diagnostic status alert.

Modbus coil	Diagnostic
126	Electronics failure
127	Coil open circuit
128	Empty pipe
129	Reverse flow
130	Ground/wiring fault
131	High process noise
132	Electronics temperature out of range
133	Electrode coat limit 1
134	Electrode coat limit 2
135	Continuous meter verification
136	Coil over current
137	Sensor electrode saturated
138	Coil power limit

Modbus coil value	Diagnostic	Description
0	Off	The diagnostic status alert will not activate when diagnostics designated as OFF are detected (default).
1	On	The diagnostic status alert will activate when a transmitter detects a diagnostic designated as ON.

## 8.3 Configure LOI/Display

### 8.3.1 Flow and totalizer display

LOI menu path	<b>Detailed Setup</b> → <b>LOI Config</b> → <b>Flow Display</b>
Modbus register	81

Use flow display to configure the parameters that will appear on the LOI flowrate screen. The flowrate screen displays two lines of information. Choose one of the following options:

- Flowrate, % of Span
- Flow, Total A
- % Span, Total A
- Flow, Total B
- % Span, Total B
- Flow, Total C
- % Span, Total C

Register value	Display
0	Flowrate and Total A (default)
1	Flowrate and Total B
2	Flowrate and Total C

### 8.3.2 Language

LOI menu path	<b>Detailed Setup → LOI Config → Language</b>
Modbus register	83

Use language to configure the display language shown on the LOI. Choose one of the following options:

Register value	Language
0	English
1	Spanish
2	German
3	French
4	Portuguese

### 8.3.3 Display lock

LOI menu path	<b>Detailed Setup → LOI Config → Disp Auto Lock</b>
Modbus register	100

The transmitter has display lock functionality to prevent unintentional configuration changes. The display can be locked manually or configured to automatically lock after a set period of time.

- OFF (default)
- 1 Minute
- 10 Minutes

The display is always locked on the flow screen.



Modbus coil value	Operating mode
0	LOI display lock is turned OFF (default)
1	LOI display lock is turned ON

### 8.3.4 Error mask

LOI menu path	<b>Detailed Setup</b> → <b>LOI Config</b> → <b>LOI Err Mask</b>
---------------	---

Use LOI error mask to turn off the analog output power error message (AO No Power). This may be desired if the analog output is not being used.

### 8.3.5 Backlight control

LOI menu path	<b>Detailed Setup</b> → <b>LOI Config</b> → <b>Backlight</b>
Modbus register	122

To conserve power, the LOI backlight can be configured to automatically turn off after a set amount of time without keypad activity.

Register value	Backlight control
0	Always OFF (default for low power)
1	10 Seconds
2	20 Seconds
3	30 Seconds
4	Always ON (default)

## 8.4 Additional parameters

The following parameters may be required for detailed configuration settings based on your application.

### 8.4.1 Coil drive frequency

LOI menu path	<b>Detailed Setup</b> → <b>More Params</b> → <b>Coil Frequency</b>
Modbus register	77

Use coil drive frequency to change the pulse rate of the coils.

- 5 Hz - The standard coil drive frequency is 5 Hz, which is sufficient for nearly all applications.
- 37 Hz - If the process fluid causes a noisy or unstable output, increase the coil drive frequency to 37.5 Hz. If the 37 Hz mode is selected, perform the auto zero function for optimum performance.

---

**Note**

37 Hz coil drive frequency should not be used for sensor sizes larger than 20-inch.

---

Register value	Configuration	Description
0	5 Hz	The standard coil drive frequency is 5 Hz, which is sufficient for nearly all applications (default).
1	37 Hz	If the process fluid causes a noisy or unstable output, increase the coil drive frequency to 37.5 Hz. If the 37 Hz mode is selected, perform the auto zero function for optimum performance.

#### Related information

[Auto zero](#)

## 8.4.2 Process density

LOI menu path	<b>Detailed Setup → More Params → Proc Density</b>
Modbus register	Density units: 29 Density value: 333, 334

Use the process density value to convert from a volumetric flow rate to a mass flow rate using the following equation:

$$Q_m = Q_v \times \rho$$

Where:

$Q_m$  is the mass flow rate

$Q_v$  is the volumetric flow rate, and

$\rho$  is the fluid density

Register value	Description
92	Pounds per cubic foot (lb/ft <sup>3</sup> )
94	Kilograms per cubic meter (kg/m <sup>3</sup> ) LOI

## 8.4.3 Reverse flow

LOI menu path	<b>Detailed Setup → Output Config → Reverse Flow</b>
Modbus coil	99

Use reverse flow to enable or disable the transmitter's ability to read flow in the opposite direction of the flow direction arrow (see [Flow direction](#)). This may occur when the process has bi-directional flow, or when either the electrode wires or the coil wires are reversed (see Troubleshooting [Remote wiring](#)). This also enables the totalizer to count in the reverse direction.

Modbus coil value	Operating mode
0	Reverse flow disabled (default)
1	Reverse flow enabled

## 8.4.4 Low flow cutoff

LOI menu path	<b>Detailed Setup → Sig Processing → Lo-Flow Cutoff</b>
Modbus register	325, 326

Low flow cutoff allows the user to set a low flow limit to be specified. The flow reading is driven to zero for flow rates below the set point. The low flow cutoff units are the same as the PV units and cannot be changed. The low flow cutoff value applies to both forward and reverse flows.

## 8.4.5 PV (flow) damping

LOI menu path	<b>Detailed Setup → Sig Processing → Damping</b>
Modbus register	321

Primary variable damping allows selection of a response time, in seconds, to a step change in flow rate. It is most often used to smooth fluctuations in output.

## 8.4.6 Signal processing

The transmitter contains several advanced functions that can be used to stabilize erratic outputs caused by process noise. The signal processing menu contains this functionality.

If the 37 Hz coil drive mode has been set, and the output is still unstable, the damping and signal processing function should be used. It is important to set the coil drive mode to 37 Hz first, so the loop response time is not increased.

The transmitter provides for a very easy and straightforward start-up, and also incorporates the capability to deal with difficult applications that have previously manifested themselves in a noisy output signal. In addition to selecting a higher coil drive frequency (37 Hz vs. 5 Hz) to isolate the flow signal from the process noise, the microprocessor can actually scrutinize each input based on three user-defined parameters to reject the noise specific to the application.

See [Digital Signal Processing](#) for the detailed description of how the signal processing works.

## 8.5 Configure special units

Special units are used when the application requires units that are not included in the flow units available from the device. Refer to [Basic setup](#) for a complete list of the available units.

## 8.5.1 Base volume unit

LOI menu path	<b>Basic Setup</b> → <b>Flow Units</b> → <b>Special Units</b> → <b>Base Vol Units</b>
Modbus register	76

Base volume unit is the unit from which the conversion is being made. Set this variable to the appropriate option.

**Table 8-8: Volume units**

Register value	Units
40	Gallons (default)
41	Liters
42	Imperial gallons
43	Cubic meters
46	Barrels (42 gallons)
112	Cubic feet
246	Cubic centimeters
247	Barrels (31 gallons)

**Table 8-9: Mass units**

Register value	Units
40	Kilograms
41	Metric tons
42	Pounds
43	Short tons

**Table 8-10: Other units**

Register value	Units
44	Feet
45	Meters

## 8.5.2 Conversion factor

LOI menu path	<b>Basic Setup</b> → <b>Flow Units</b> → <b>Special Units</b> → <b>Conv Factor</b>
Modbus register	323, 324

The special units conversion factor is used to convert base units to special units. For a straight conversion of units from one unit of measure to a different unit of measure, the conversion factor is the number of base units in the new unit.

Example: If you are converting from gallons to barrels and there are 31 gallons in a barrel, the conversion factor is 31.

### 8.5.3 Base time unit

LOI menu path	<b>Basic Setup</b> → <b>Flow Units</b> → <b>Special Units</b> → <b>Base Time Unit</b>
Modbus register	75

Base time unit provides the time unit from which to calculate the special units. For example, if your special units is a volume per minute, select minutes.

Register value	Units
50	Minute (default)
51	Second
52	Hour
53	Day

### 8.5.4 Special volume unit

LOI menu path	<b>Basic Setup</b> → <b>Flow Units</b> → <b>Special Units</b> → <b>Volume Unit</b>
Modbus register	411, 412

Special volume unit enables you to display the volume unit format to which you have converted the base volume units.

Example: If the special units are abc/min, the special volume variable is abc. The volume units variable is also used in totalizing the special units flow.

### 8.5.5 Special flow rate unit

LOI menu path	<b>Basic Setup</b> → <b>Flow Units</b> → <b>Special Units</b> → <b>Rate Unit</b>
Modbus register	409, 410

Flow rate unit is a format variable that provides a record of the units to which you are converting. The Handheld Communicator will display a special units designator as the units format for your primary variable. The actual special units setting you define will not appear. Four characters are available to store the new units designation. The LOI will display the four character designation as configured.

Example: To display flow in acre-feet per day, and acre-foot is equal to 43560 cubic feet, the procedure would be:

1. Set the volume unit to ACFT.
2. Set the base volume unit to ft3.
3. Set the conversion factor to 43560.
4. Set the time base unit to Day.
5. Set the flow rate unit to AF/D.



# 9 Advanced Diagnostics Configuration

## 9.1 Introduction

Rosemount magnetic flowmeters provide device diagnostics that detect and warn of abnormal situations throughout the life of the meter—from installation to maintenance and meter verification. With Rosemount magnetic flowmeter diagnostics enabled, plant availability and throughput can be improved, and costs through simplified installation, maintenance and troubleshooting can be reduced.

**Table 9-1: Modbus diagnostics availability**

Diagnostic name	Diagnostic category	Product capability
Modbus status	Communication	Standard
Listen only mode	Communication	Standard
Restart Modbus communication	Communication	Standard
Reset Modbus communication	Communication	Standard

**Table 9-2: Basic diagnostics availability**

Diagnostic name	Diagnostic category	Product capability
Tunable Empty Pipe	Process	Standard
Electronics Temperature	Maintenance	Standard
Coil Fault	Maintenance	Standard
Transmitter Fault	Maintenance	Standard
Reverse Flow	Process	Standard
Electrode Saturation	Process	Standard
Coil Current	Maintenance	Standard
Coil Power	Maintenance	Standard
Grounding and Wiring Fault	Installation	Standard

**Table 9-3: Advanced diagnostics availability**

Diagnostic name	Diagnostic category	Product capability
High Process Noise	Process	Suite 1 (DA1)
Coated Electrode Detection	Process	Suite 1 (DA1)
Commanded Meter Verification	Meter Health	Suite 2 (DA2)
Continuous Meter Verification	Meter Health	Suite 2 (DA2)
4-20 mA Loop Verification	Installation	Suite 2 (DA2)

## 9.2 Modbus communication diagnostics

### Modbus status

LOI menu path	<b>Diagnostics → Modbus Diag → Modbus Status</b>
---------------	--

Displays the status of the Modbus communication. There are three possible status modes:

<b>Active</b>	The transmitter is communicating with the host with no errors.
<b>Inactive</b>	The transmitter is not communicating with the host.
<b>Communication Mismatch</b>	The transmitter is communicating with the host, but the configuration parameters between the transmitter and the host do not match, resulting in incorrect parsing of the Modbus data.

### Listen only mode

LOI menu path	<b>Diagnostics → Modbus Diag → Listen Only MD</b>
---------------	---

The transmitter has been placed into listen only mode through either the host system or LOI. The transmitter is not actively sending Modbus data, but is receiving commands from the host system.

### Restart Modbus communication

LOI menu path	<b>Diagnostics → Modbus Diag → Restart MB Com</b>
---------------	---

This function is only available through the LOI. This function can be used to perform a soft reset of the Modbus communication.

### Reset Modbus configuration

LOI menu path	<b>Diagnostics → Modbus Diag → Reset MB Config</b>
---------------	--

This function is only available through the LOI. This will initiate a method to reset all Modbus communication parameters back to the factory default. Activating this method will result in a series of screens that describe what the default parameters are, and then allow the user to proceed with the reset or cancel the method. Default configuration parameters are shown in the following table.

Parameter	Default value
Address	1
Floating point byte order	0-1-2-3
Baud rate	19,200
Parity	Even
Stop bits	1
Minimum response delay	10 ms

## 9.3 Licensing and enabling

All advanced diagnostics are licensed by ordering option code DA1, DA2, or both. In the event that a diagnostic option is not ordered, advanced diagnostics can be licensed in the field through the use of a license key. Each transmitter has a unique license key specific



to the diagnostic option code. A trial license is also available to enable the advanced diagnostics. This temporary functionality will be automatically disabled after 30-days or when power to the transmitter is cycled, whichever occurs first. This trial code can be used a maximum of three times per transmitter. See the detailed procedures below for entering the license key and enabling the advanced diagnostics. To obtain a permanent or trial license key, contact an Emerson representative.

### 9.3.1 Licensing the diagnostics

#### Procedure

1. Power up the transmitter.
2. Verify the software version is 4.4 software or later.

LOI menu path	<b>Detailed Setup → Device Info → Revision Num → Software Num</b>
---------------	---

3. Determine the Device ID.

LOI menu path	<b>Detailed Setup → Device Info → Device ID</b>
Modbus register	151, 152

4. Obtain a license key from an Emerson representative.
5. Enter license key.

LOI menu path	<b>Diagnostics → Advanced Diag → Licensing → License Key → License Key</b>
Modbus coil	157, 158

## 9.4 Tunable empty pipe detection

The tunable empty pipe detection provides a means of minimizing issues and false readings when the pipe is empty. This is most important in batching applications where the pipe may run empty with some regularity. If the pipe is empty, this diagnostic will activate, set the flow rate to 0, and deliver an alert.

#### Turning empty pipe on/off

LOI menu path	<b>Diagnostics → Diag Controls → Empty Pipe</b>
---------------	---

The tunable empty pipe detection diagnostic can be turned on or off as required by the application. The empty pipe diagnostic is shipped turned ON by default.

### 9.4.1 Tunable empty pipe parameters

The tunable empty pipe diagnostic has one read-only parameter, and two parameters that can be custom configured to optimize the diagnostic performance.

#### Empty pipe (EP) value

LOI menu path	<b>Diagnostics → Variables → Empty Pipe</b>
Modbus register	219, 220

This parameter shows the current empty pipe value. This is a read-only value. This number is a unit-less number and is calculated based on multiple installation and process variables such as sensor type, line size, process fluid properties, and wiring. If the empty pipe value exceeds the empty pipe trigger level for a specified number of updates, then the empty pipe diagnostic alert will activate.

#### Empty pipe (EP) trigger level

LOI menu path	<b>Diagnostics → Basic Diag → Empty Pipe → EP Trig Level</b>
Modbus register	335, 336

Limits: 3 to 2000

Empty pipe trigger level is the threshold limit that the empty pipe value must exceed before the empty pipe diagnostic alert activates. The default setting from the factory is 100.

#### Empty pipe (EP) counts

LOI menu path	<b>Diagnostics → Basic Diag → Empty Pipe → EP Counts</b>
Modbus register	86

Limits: 2 to 50

Empty pipe counts is the number of consecutive updates that the transmitter must receive where the empty pipe value exceeds the empty pipe trigger level before the empty pipe diagnostic alert activates. The default setting from the factory is 5.

## 9.4.2 Optimizing tunable empty pipe

The tunable empty pipe diagnostic is set at the factory to properly diagnose most applications. If this diagnostic activates, the following procedure can be followed to optimize the empty pipe diagnostic for the application.

#### Procedure

1. Record the empty pipe value with a full pipe condition.

##### Example

Full reading = 0.2

2. Record the empty pipe value with an empty pipe condition.

##### Example

Empty reading = 80.0

3. Set the empty pipe trigger level to a value between the full and empty readings.  
For increased sensitivity to empty pipe conditions, set the trigger level to a value closer to the full pipe value.

##### Example

Set the trigger level to 25.0

4. Set the empty pipe counts to a value corresponding to the desired sensitivity level for the diagnostic.  
For applications with entrained air or potential air slugs, less sensitivity may be desired.

**Example**

Set the counts to 10

## 9.5 Electronics temperature

The transmitter continuously monitors the temperature of the internal electronics. If the measured electronics temperature exceeds the operating limits of -40 to 140 °F (-40 to 60 °C) the transmitter will go into alarm and generate an alert.

### 9.5.1 Turning electronics temperature on/off

LOI menu path	<b>Diagnostics → Diag Controls → Elect Temp</b>
Modbus coil	120

The electronics temperature diagnostic can be turned on or off as required by the application. The electronics temperature diagnostic will be turned on by default.

Modbus coil value	Diagnostic mode
0	Electronics temperature diagnostic is off.
1	Electronics temperature diagnostic is on (default).

### 9.5.2 Electronics temperature parameters

The electronics temperature diagnostic has one read-only parameter. It does not have any configurable parameters.

LOI menu path	<b>Diagnostics → Variables → Elect Temp</b>
Modbus register	209, 210

This parameter shows the current temperature of the electronics. This is a read-only value.

## 9.6 Ground/wiring fault detection

The transmitter continuously monitors signal amplitudes over a wide range of frequencies. For the ground/wiring fault detection diagnostic, the transmitter specifically looks at the signal amplitude at frequencies of 50 Hz and 60 Hz which are the common AC cycle frequencies found throughout the world. If the amplitude of the signal at either of these frequencies exceeds 5 mV, that is an indication that there is a ground or wiring issue and that stray electrical signals are getting into the transmitter. The diagnostic alert will activate, indicating that the ground and wiring of the installation should be carefully reviewed.

The ground/wiring fault detection diagnostic provides a means of verifying installations are done correctly. If the installation is not wired or grounded properly, this diagnostic will activate and deliver an alert. This diagnostic can also detect if the grounding is lost overtime due to corrosion or another root cause.

## 9.6.1 Turning ground/wiring fault on/off

LOI menu path	<b>Diagnostics → Diag Controls → Ground/Wiring</b>
Modbus coil	119

The ground/wiring fault detection diagnostic can be turned on or off as required by the application. If the advanced diagnostics suite 1 (DA1 Option) was ordered, then the ground/wiring fault detection diagnostic will be turned on. If DA1 was not ordered or licensed, this diagnostic is not available.

Modbus coil value	Diagnostic mode
0	Grounding and wiring diagnostic is off.
1	Grounding and wiring diagnostic on (default).

## 9.6.2 Ground/wiring fault parameters

The ground/wiring fault detection diagnostic has one read-only parameter. It does not have any configurable parameters.

### Line noise

LOI menu path	<b>Diagnostics → Variables → Line Noise</b>
Modbus host	211, 212

The line noise parameter shows the amplitude of the line noise. This is a read-only value. This number is a measure of the signal strength at 50/60 Hz. If the line noise value exceeds 5 mV, then the ground/wiring fault diagnostic alert will activate.

## 9.7 High process noise detection

The high process noise diagnostic detects if there is a process condition causing an unstable or noisy reading that is not an actual flow variation. A common cause of high process noise is slurry flow, like pulp stock or mining slurries. Other conditions that cause this diagnostic to activate are high levels of chemical reaction or entrained gas in the liquid. If unusual noise or flow variation is seen, this diagnostic will activate and deliver an alert. If this situation exists and is left without remedy, it will add additional uncertainty and noise to the flow reading.

## 9.7.1 Turning high process noise on/off

LOI menu path	<b>Diagnostics → Diag Controls → Process Noise</b>
Modbus coil	118

The high process noise diagnostic can be turned on or off as required by the application. If the advanced diagnostics suite 1 (DA1 Option) was ordered, then the high process noise diagnostic will be turned on. If DA1 was not ordered or licensed, this diagnostic is not available.

Modbus coil value	Diagnostic mode
0	High process noise diagnostic is off.
1	High process noise diagnostic is on (default).

## 9.7.2 High process noise parameters

The high process noise diagnostic has two read-only parameters. It does not have any configurable parameters. This diagnostic requires that flow be present in the pipe and the velocity be greater than 1 ft/s (0.3 m/s).

### 5 Hz signal to noise ratio (SNR)

LOI menu path	<b>Diagnostics → Variables → 5Hz SNR</b>
Modbus register	213, 214

This parameter shows the value of the signal to noise ratio at the coil drive frequency of 5 Hz. This is a read-only value. This number is a measure of the signal strength at 5 Hz relative to the amount of process noise. If the transmitter is operating in 5 Hz mode, and the signal to noise ratio remains below 25 for one minute, then the high process noise diagnostic alert will activate.

### 37 Hz signal to noise ratio (SNR)

LOI menu path	<b>Diagnostics → Variables → 37Hz SNR</b>
Modbus register	215, 216

This parameter shows the current value of the signal to noise ratio at the coil drive frequency of 37 Hz. This is a read-only value. This number is a measure of the signal strength at 37 Hz relative to the amount of process noise. If the transmitter is operating in 37 Hz mode, and the signal to noise ratio remains below 25 for one minute, then the high process noise diagnostic alert will activate.

## 9.8 Coated electrode detection

The coated electrode detection diagnostic provides a means of monitoring insulating coating buildup on the measurement electrodes. If coating is not detected, buildup over time can lead to a compromised flow measurement. This diagnostic can detect if the electrode is coated and if the amount of coating is affecting the flow measurement. There are two levels of electrode coating.

- Limit 1 indicates when coating is starting to occur, but has not compromised the flow measurement.
- Limit 2 indicates when coating is affecting the flow measurement and the meter should be serviced immediately.

### 9.8.1 Turning coated electrode detection on/off

LOI menu path	<b>Diagnostics → Diag Controls → Elec Coating</b>
---------------	---

The coated electrode detection diagnostic can be turned on or off as required by the application. If the advanced diagnostics suite 1 (DA1 option) was ordered, then the coated electrode detection diagnostic will be turned on. If DA1 was not ordered or licensed, this diagnostic is not available.

Modbus coil value	Diagnostic mode
0	Electrode coating diagnostic is off.
1	Electrode coating diagnostic is on (default).

### 9.8.2 Coated electrode parameters

The coated electrode detection diagnostic has four parameters. Two are read-only and two are configurable parameters. The electrode coating parameters need to be initially monitored to accurately set the electrode coating limit levels for each application.

#### Electrode coating (EC) value

LOI menu path	<b>Diagnostics → Advanced Diag → Elec Coating → EC Current Val</b>
Modbus register	221, 222

The electrode coating value reads the value of the coated electrode detection diagnostic.

#### Electrode coating (EC) level 1 limit

LOI menu path	<b>Diagnostics → Advanced Diag → Elec Coat → EC Limit 1</b>
Modbus register	353, 354

Set the criteria for the electrode coating limit 1 which indicates when coating is starting to occur, but has not compromised the flow measurement. The default value for this parameter is 1000 k Ohm.

### Electrode coating (EC) level 2 limit

LOI menu path	<b>Diagnostics → Advanced Diag → Elec Coat → EC Limit 2</b>
Modbus register	355, 356

Set the criteria for the electrode coating limit 2 which indicates when coating is affecting the flow measurement and the meter should be serviced immediately. The default value for this parameter is 2000 k Ohm.

### Maximum electrode coating (EC)

LOI menu path	<b>Diagnostics → Advanced Diag → Elec Coat → EC Max Value</b>
Modbus register	281, 282

The maximum electrode coating value reads the maximum value of the coated electrode detection diagnostic since the last maximum value reset.

### Clear maximum electrode value

LOI menu path	<b>Diagnostics → Advanced Diag → Elec Coat → Reset Max Val</b>
Modbus register	115

Use this method to reset the maximum electrode coating value.

Modbus coil value	Operation
0	Monitor maximum electrode coating value.
1	Reset maximum electrode coating value.

## 9.9 Smart Meter Verification

The Smart Meter Verification diagnostic provides a means of verifying the flowmeter is within calibration without removing the sensor from the process. This diagnostic test provides a review of the transmitter and sensor's critical parameters as a means to document verification of calibration. The results of this diagnostic provide the deviation amount from expected values and a pass/fail summary against user-defined criteria for the application and conditions. The Smart Meter Verification diagnostic can be configured to run continuously in the background during normal operation, or it can be manually initiated as required by the application.

## 9.9.1 Sensor baseline parameters

The Smart Meter Verification diagnostic functions by taking a baseline sensor signature and then comparing measurements taken during the verification test to these baseline results.

The sensor signature describes the magnetic behavior of the sensor. Based on Faraday's law, the induced voltage measured on the electrodes is proportional to the magnetic field strength. Thus, any changes in the magnetic field will result in a calibration shift of the sensor. Having the transmitter take an initial sensor signature when first installed will provide the baseline for the verification tests that are done in the future. There are three specific measurements that are stored in the transmitter's non-volatile memory that are used when performing the calibration verification.

### Coil circuit resistance

LOI menu path	<b>Diagnostics → Advanced Diag → Meter Verif → Sensr Baseline → Values → Coil Resist</b>
Modbus register	287, 288

The coil resistance is a measurement of the coil circuit health. This value is used as a baseline to determine if the coil circuit is still operating correctly.

### Coil inductance (signature)

LOI menu path	<b>Diagnostics → Advanced Diag → Meter Verif → Sensr Baseline → Values → Coil Inductnce</b>
Modbus register	285, 286

The coil inductance is a measurement of the magnetic field strength. This value is used as a baseline to determine if a sensor calibration shift has occurred.

### Electrode circuit resistance

LOI menu path	<b>Diagnostics → Advanced Diag → Meter Verif → Sensr Baseline → Values → Electrode Res</b>
Modbus register	289, 290

The electrode circuit resistance is a measurement of the electrode circuit health. This value is used as a baseline to determine if the electrode circuit is still operating correctly.

## 9.9.2 Establishing the sensor baseline

The first step in running the Smart Meter Verification test is establishing the reference baseline that the test will use as the baseline for comparison. This is accomplished by having the transmitter take a baseline of the sensor.



### Reset baseline (re-signature meter)

LOI menu path	<b>Diagnostics → Advanced Diag → Meter Verif → Sensr Baseline → Reset Baseline</b>
Modbus coil	113

Having the transmitter take an initial sensor baseline when first installed will provide the comparison point for the verification tests that are done in the future. The sensor baseline should be taken during the start-up process when the transmitter is first connected to the sensor, with a full line, and ideally with no flow in the line. Running the sensor baseline procedure when there is flow in the line is permissible, but this may introduce some noise into the electrode circuit resistance measurement. If an empty pipe condition exists, then the sensor baseline should only be run for the coils.

#### Note

For high temperature applications, it is a best practice to take the sensor baseline when the process fluid and sensor have reached their normal operating temperature if that will be operating condition during test measurements.

Once the sensor baseline process is complete, the measurements taken during this procedure are stored in non-volatile memory to prevent loss in the event of a power interruption to the meter. This initial sensor signature is required for both manual and continuous Smart Meter Verification.

### Reset baseline (re-signature meter)

To establish the sensor baseline:

1. Determine the components of the sensor to be baselined.
2. Write the corresponding component value to Modbus register 106. See below for register values.
3. Initiate the sensor baseline by writing 1 to Modbus coil 113.

When the sensor baseline is complete, the register and coil written above will return to their default values.

Modbus coil value	Baseline operation
0	No action (default)
1	Initiate sensor baseline

### Baseline component selection

Modbus coil	106
-------------	-----

Use the register values below to select the components to be baselined. This register must be set before initiating the sensor baseline.

Register value	Baseline component selection
0	All (coils and electrodes)
1	Coils
2	Electrodes
255	Not initiated (default)

### Recall values (recall last saved)

LOI menu path	<b>Diagnostics → Advanced Diag → Meter Verif → Sensr Baseline → Recall Values</b>
Modbus coil	114

If the sensor baseline was reset accidentally or incorrectly, this function will restore the previously saved sensor baseline values.

Modbus coil value	Signature operation
0	No action
1	Recall last signature values

## 9.9.3 Smart Meter Verification test criteria

The Smart Meter Verification diagnostic provides the ability to customize the test criteria to which the verification must be tested. The test criteria can be set for each of the flow conditions discussed above.

### No flow limit

LOI menu path	<b>Diagnostics → Advanced Diag → Meter Verif → Test Criteria → No Flow</b>
Modbus register	89

Set the test criteria for the no flow condition. The factory default for this value is set to five percent with limits configurable between one and ten percent. This parameter applies to manually initiated test only.

### Flowing full limit

LOI menu path	<b>Diagnostics → Advanced Diag → Meter Verif → Test Criteria → Flowing, Full</b>
Modbus register	88

Set the test criteria for the flowing, full condition. The factory default for this value is set to five percent with limits configurable between one and ten percent. This parameter applies to manually-initiated tests only.

### Empty pipe limit

LOI menu path	<b>Diagnostics → Advanced Diag → Meter Verif → Test Criteria → Empty Pipe</b>
Modbus register	87

Set the test criteria for the empty pipe condition. The factory default for this value is set to five percent with limits configurable between one and ten percent. This parameter applies to manually-initiated test only.

### Continuous limit

LOI menu path	<b>Diagnostics → Advanced Diag → Meter Verif → Test Criteria → Continual</b>
Modbus register	90

Set the test criteria for the continuous Smart Meter Verification diagnostic. The factory default for this value is set to five percent with limits configurable between two and ten percent. If the tolerance band is set too tightly, under empty pipe conditions or noisy flowing conditions, a false failure of the transmitter test may occur.

## 9.10 Run commanded Smart Meter Verification

LOI menu path	<b>Diagnostics → Advanced Diag → Meter Verif → Run Meter Ver</b>
Modbus coil	112

The Smart Meter Verification diagnostic will be available if the Smart Meter Verification Professional (DA2) was ordered. If DA2 was not ordered or licensed, this diagnostic will not be available. This method will initiate the commanded meter verification test.

To run Smart Meter Verification:

1. Determine the existing test condition.
2. Write the corresponding test condition value to Modbus register 108.
3. Determine the test scope.
4. Write the corresponding test scope value to Modbus register 107.
5. Initiate Smart Meter Verification by writing 1 to Modbus coil 112.

Modbus coil value	Smart Meter Verification mode
0	No action (default)
1	Initiate Smart Meter Verifictaion test

When Smart Meter Verification is complete, the Modbus registers and coil entered above will return to their default values.

## 9.10.1 Test conditions

LOI menu path	<b>Diagnostics → Advanced Diag → Meter Verif → Run Meter Ver → Test Condition</b>
Modbus host	108

Smart Meter Verification can be initiated under three possible test conditions. This parameter is set at the time that the sensor baseline or Smart Meter Verification test is manually initiated.

Register value	Units
1	No flow, full pipe
2	Flow, full pipe
3	Empty pipe
255	Not initiated (default)

- No flow** Run the Smart Meter Verification test with a full pipe and no flow in the line. Running the Smart Meter Verification test under this condition provides the most accurate results and the best indication of magnetic flowmeter health.
- Flowing full** Run the Smart Meter Verification test with a full pipe and flow in the line. Running the Smart Meter Verification test under this condition provides the ability to verify the magnetic flowmeter health without shutting down the process flow in applications when a shutdown is not possible. Running the diagnostic under flowing conditions can cause a false test failure if there is significant process noise present.
- Empty pipe** Run the Smart Meter Verification test with an empty pipe. Running the Smart Meter Verification test under this condition provides the ability to verify the magnetic flowmeter health with an empty pipe. Running the verification diagnostic under empty pipe conditions will not check the electrode circuit health.

## 9.10.2 Test scope

LOI menu path	<b>Diagnostics</b> → <b>Advanced Diag</b> → <b>Meter Verif</b> → <b>Run Meter Ver</b> → <b>Test Scope</b>
Modbus register	107

The commanded Smart Meter Verification test can be used to verify the entire flowmeter installation or individual parts such as the transmitter or sensor. This parameter is set at the time that the Smart Meter Verification test is manually initiated. There are three test scopes from which to choose.

Use the register values below to set the test scope. This register must be set before initiating Smart Meter Verification.

Register value	Test scope
0	All (sensor and transmitter)
1	Sensor
2	Transmitter
255	Not initiated (default)

- All** Run the Smart Meter Verification test and verify the entire flowmeter installation. This parameter results in the diagnostic performing the transmitter calibration verification, sensor calibration verification, coil health check, and electrode health check. Transmitter calibration and sensor calibration are verified to the percentage associated with the test condition selected when the test was initiated. This setting applies to manually initiated tests only.
- Transmitter** Run the Smart Meter Verification test on the transmitter only. This results in the verification test only checking the transmitter calibration to the limits of the test criteria selected when the verification test was initiated. This setting applies to manually initiated tests only.
- Sensor (coils and electrodes)** Run the Smart Meter Verification test on the sensor only. This results in the verification test checking the sensor calibration to the limits of the test criteria selected when the Smart Meter Verification test was initiated, verifying the coil circuit health, and the electrode circuit health. This setting applies to manually initiated tests only.

## 9.11 Continuous Smart Meter Verification

Continuous Smart Meter Verification can be used to monitor and verify the health of the flowmeter system. The continuous Smart Meter Verification will not report results until 30 minutes after powering up to ensure the system is stable and to avoid false failures.

### 9.11.1 Test scope

Continuous Smart Meter Verification can be configured to monitor the sensor coils, electrodes, and transmitter calibration. All of these parameters can be individually enabled or disabled. These parameters apply to continuous Smart Meter Verification only.

### Coils

LOI menu path	<b>Diagnostics</b> → <b>Diag Controls</b> → <b>Cont Meter Ver</b> → <b>Coils</b>
Modbus coil	122

Continuously monitor the sensor coil circuit by enabling this continuous Smart Meter Verification parameter.

Register value	Units
0	Exclude coil tests in the continuous Smart Meter Verification diagnostic (default).
1	Include coil tests in the continuous Smart Meter Verification diagnostic.

### Electrodes

LOI menu path	<b>Diagnostics</b> → <b>Diag Controls</b> → <b>Cont Meter Ver</b> → <b>Electrodes</b>
Modbus coil	123

Continuously monitor the electrode resistance by enabling this continuous Smart Meter Verification parameter.

Register value	Units
0	Exclude electrodes tests in the continuous Smart Meter Verification diagnostic (default).
1	Include electrodes tests in the continuous Smart Meter Verification diagnostic.

### Transmitter

LOI menu path	<b>Diagnostics</b> → <b>Diag Controls</b> → <b>Cont Meter Ver</b> → <b>Transmitter</b>
Modbus coil	124

Continuously monitor the transmitter calibration by enabling this continuous Smart Meter Verification parameter.

Register value	Units
0	Exclude transmitter tests in the continuous Smart Meter Verification diagnostic (default).
1	Include transmitter tests in the continuous Smart Meter Verification diagnostic.

## 9.12 SMART Meter Verification test results

If the SMART Meter Verification test is manually initiated, the transmitter will make several measurements to verify the transmitter calibration, sensor calibration, coil circuit health, and electrode circuits health. The results of these tests can be reviewed and recorded on the calibration verification report (see [Optimizing continuous Smart Meter Verification](#)). This report can be used to validate that the meter is within the required calibration limits to comply with governmental regulatory agencies.

Depending on the method used to view the results, they will be displayed in either a menu structure, as a method, or in the report format. When using the LOI, the parameters are viewed as a method using the left arrow key to cycle through the results. In ProLink III, the calibration report is populated with the necessary data eliminating the need to manually complete the report.

The results are displayed in the order found in the following table. Each parameter displays a value used in the SMART Meter Verification diagnostic evaluation of the meter health.

**Table 9-4: Manual Smart Meter Verification Test Parameters**

	Parameter	Modbus register
1	Test Condition	36
2	Test Criteria	35
3	8714i Test Result	30
4	Simulated Velocity	267, 268
5	Actual Velocity	269, 270
6	Velocity Deviation	271, 272
7	Xmtr Cal Test Result	34
8	Sensor Cal Deviation	273, 274
9	Sensor Cal Test Result	31
10	Coil Circuit Test Result	32
11	Electrode Circuit Test Result	33

**Table 9-5: Continuous SMART Meter Verification Test Parameters**

	Parameter	Modbus register
1	Continuous Limit	90
2	Simulated Velocity	267, 268
3	Actual Velocity	235, 236
4	Velocity Deviation	223, 224
5	Coil Signature	229, 230
6	Sensor Cal Deviation	231, 232
7	Coil Resistance	227, 228
8	Electrode Resistance	225, 226

## 9.13 Smart Meter Verification measurements

The Smart Meter Verification test will make measurements of the coil resistance, coil inductance, and electrode resistance and compare these values to the values taken during the sensor baseline process to determine the sensor calibration deviation, the coil circuit health, and the electrode circuit health. In addition, the measurements taken by this test can provide additional information when troubleshooting the meter.

### Coil circuit resistance

LOI menu path	Manual: <b>Diagnostics</b> → <b>Advanced Diag</b> → <b>Meter Verif</b> → <b>Measurements</b> → <b>Manual Measure</b> → <b>Coil Resist</b> Continuous: <b>Diagnostics</b> → <b>Advanced Diag</b> → <b>Meter Verif</b> → <b>Measurements</b> → <b>Continual Meas</b> → <b>Coil Resist</b>
Modbus register	Manual: 277-278 Continuous: 227, 228

The coil circuit resistance is a measurement of the coil circuit health. This value is compared to the coil circuit resistance signature measurement taken during the sensor baseline process to determine coil circuit health. This value can be continuously monitored using continuous Smart Meter Verification.

### Coil inductance (signature)

LOI menu path	Manual: <b>Diagnostics</b> → <b>Advanced Diag</b> → <b>Meter Verif</b> → <b>Measurements</b> → <b>Manual Measure</b> → <b>Coil Inductance</b> Continuous: <b>Diagnostics</b> → <b>Advanced Diag</b> → <b>Meter Verif</b> → <b>Measurements</b> → <b>Continual Meas</b> → <b>Coil Inductance</b>
Modbus register	Manual: 275, 276 Continuous: 229, 230

The coil inductance is a measurement of the magnetic field strength. This value is compared to the coil inductance signature measurement taken during the sensor baseline process to determine sensor calibration deviation. This value can be continuously monitored using continuous Smart Meter Verification.

### Electrode circuit resistance

LOI menu path	Manual: <b>Diagnostics</b> → <b>Advanced Diag</b> → <b>Meter Verif</b> → <b>Measurements</b> → <b>Manual Measure</b> → <b>Electrode Res</b> Continuous: <b>Diagnostics</b> → <b>Advanced Diag</b> → <b>Meter Verif</b> → <b>Measurements</b> → <b>Continual Meas</b> → <b>Electrode Res</b>
Modbus register	Manual: 279, 280 Continuous: 225, 226

The electrode circuit resistance is a measurement of the electrode circuit health. This value is compared to the electrode circuit resistance signature measurement taken during the sensor baseline process to determine electrode circuit health. This value can be continuously monitored using continuous Smart Meter Verification.

### Actual velocity

LOI menu path	Manual: <b>Diagnostics</b> → <b>Advanced Diag</b> → <b>Meter Verif</b> → <b>Measurements</b> → <b>Manual Measure</b> → <b>ActualVelocity</b> Continuous: <b>Diagnostics</b> → <b>Advanced Diag</b> → <b>Meter Verif</b> → <b>Measurements</b> → <b>Continual Meas</b> → <b>ActualVelocity</b>
Modbus register	Manual: 269, 270 Continuous: 235, 236

The actual velocity is a measurement of the simulated velocity signal. This value is compared to the simulated velocity to determine transmitter calibration deviation. This value can be continuously monitored using continuous Smart Meter Verification.



### Flow simulation deviation

LOI menu path	Manual: → <b>Diagnostics</b> → <b>Variables</b> → <b>MV Results</b> → <b>Manual Results</b> → <b>Flow Sim Dev</b> Continuous: → <b>Diagnostics</b> → <b>Variables</b> → <b>MV Results</b> → <b>Continual Res</b> → <b>Flow Sim Dev</b>
Modbus register	Manual: 271, 272 Continuous: 223, 224

The flow simulation deviation is a measurement of the percent difference between the simulated velocity and the actual measured velocity from the transmitter calibration verification test. This value can be continuously monitored using continuous Smart Meter Verification.

## 9.14 Optimizing the Smart Meter Verification

The Smart Meter Verification diagnostic can be optimized by setting the test criteria to the desired levels necessary to meet the compliance requirements of the application. The following examples below will provide some guidance on how to set these levels.

- Example 1** An effluent meter must be certified annually to comply with environmental regulations. This example regulation requires that the meter be certified to five percent. Since this is an effluent meter, shutting down the process may not be viable. In this instance, the Smart Meter Verification test will be performed under flowing conditions. Set the test criteria for flowing, full to five percent to meet the requirements of the governmental agencies.
- Example 2** A pharmaceutical company requires bi-annual verification of meter calibration on a critical feed line for one of their products. This is an internal standard, and the plant requires a calibration record be kept on-hand. Meter calibration on this process must meet two percent. The process is a batch process so it is possible to perform the calibration verification with the line full and with no flow. Since the Smart Meter Verification test can be run under no flow conditions, set the test criteria for no flow to two percent to comply with the necessary plant standards.
- Example 3** A food and beverage company requires an annual calibration of a meter on a product line. The plant standard calls for the accuracy to be three percent or better. They manufacture this product in batches, and the measurement cannot be interrupted when a batch is in process. When the batch is complete, the line goes empty. Since there is no means of performing the Smart Meter Verification test while there is product in the line, the test must be performed under empty pipe conditions. The test criteria for empty pipe should be set to three percent, and it should be noted that the electrode circuit health cannot be verified.

### 9.14.1 Optimizing continuous Smart Meter Verification

For continuous Smart Meter Verification, there is only one test criteria value to configure, and it will be used for all flow conditions. The factory default is set to five percent to minimize the potential for false failures under empty pipe conditions. For best results, set the criteria to match the maximum value of the three test criteria set during commanded meter verification (no flow, flowing full, and empty pipe).

For example, a plant might set the following commanded meter verification test criteria: two percent for no flow, three percent for flowing full, and four percent for empty pipe.

In this case, the maximum test criterion is four percent, so the test criteria for continuous Smart Meter Verification should be set to four percent. If the tolerance band is set too tightly, under empty pipe conditions or noisy flowing conditions, a false failure of the transmitter test may occur.

### Manual Calibration Verification Results

Report parameters	
User Name: _____	Calibration Conditions: <input type="checkbox"/> Internal <input type="checkbox"/> External
Tag #: _____	Test Conditions: <input type="checkbox"/> Flowing <input type="checkbox"/> No Flow, Full Pipe <input type="checkbox"/> Empty Pipe
Flowmeter information and configuration	
Software Tag:	
Calibration Number:	
Line Size:	PV Damping: _____ —
Transmitter calibration verification results	
Simulated Velocity:	Sensor calibration verification results
Actual Velocity:	Sensor Deviation %: _____
Deviation %:	Sensor Test: <input type="checkbox"/> PASS / <input type="checkbox"/> FAIL / <input type="checkbox"/> NOT TESTED
Transmitter: <input type="checkbox"/> PASS / <input type="checkbox"/> FAIL / <input type="checkbox"/> NOT TESTED	Coil Circuit Test: <input type="checkbox"/> PASS / <input type="checkbox"/> FAIL / <input type="checkbox"/> NOT TESTED
Electrode Circuit Test: <input type="checkbox"/> PASS / <input type="checkbox"/> FAIL / <input type="checkbox"/> NOT TESTED	
Summary of Calibration Verification results	
Verification Results: The result of the flowmeter verification test is: <input type="checkbox"/> PASSED / <input type="checkbox"/> FAILED	
Verification Criteria: This meter was verified to be functioning within _____ % of deviation from the original test parameters.	
Signature: _____ _____	Date: _____ _____

# 10 Digital Signal Processing

## 10.1 Introduction

Magmeters are used in applications that can create noisy flow readings. The transmitter has the capability to deal with difficult applications that have previously manifested themselves in a noisy output signal. In addition to selecting a higher coil drive frequency (37 Hz vs. 5 Hz) to isolate the flow signal from the process noise, the microprocessor has digital signal processing that is capable of rejecting the noise specific to the application. This section explains the different types of process noise, provides instructions for optimizing the flow reading in noisy applications, and provides a detailed description of the digital signal processing functionality.

## 10.2 Process noise profiles

### 1/f noise

This type of noise has higher amplitudes at lower frequencies, but generally degrades over increasing frequencies. Potential sources of 1/f noise include chemical mixing and slurry flow particles rubbing against the electrodes.

### Spike noise

This type of noise generally results in a high amplitude signal at specific frequencies, which can vary depending on the source of the noise. Common sources of spike noise include chemical injections directly upstream of the flowmeter, hydraulic pumps, and slurry flows with low concentrations of particles in the stream. The particles bounce on the electrode generating a "spike" in the electrode signal. An example of this type of flow stream would be a recycle flow in a paper mill.

### White noise

This type of noise results in a high amplitude signal that is relatively constant over the frequency range. Common sources of white noise include chemical reactions or mixing that occurs as the fluid passes through the flow meter and high concentration slurry flows where the particulates are constantly passing over the electrode head. An example of this type of flow stream would be a basis weight stream in a paper mill.

## 10.3 High process noise diagnostic

The transmitter continuously monitors signal amplitudes over a wide range of frequencies. For the high process noise diagnostic, the transmitter specifically looks at the noise amplitude adjacent to the Low and High coil drive frequencies. The noise values are used to calculate a signal-to-noise ratio for both drive frequencies. If the signal-to-noise ratio is less than 25 at the currently selected coil drive frequency, the high process noise diagnostic will trip, indicating that the flow signal may be compromised.

### Related information

[High process noise detection](#)

## 10.4 Optimizing flow reading in noisy applications

If the flow reading is unstable, first check the wiring, grounding, and process reference associated with the magnetic flowmeter system. Ensure that the following conditions are met:

- Ground straps are attached to the adjacent flange or ground ring
- Grounding rings, lining protectors, or a process reference electrode are being used in lined or non-conductive piping

The causes of unstable transmitter output can usually be traced to extraneous voltages on the measuring electrodes. This “process noise” can arise from several causes including electrochemical reactions between the fluid and the electrode, chemical reactions in the process itself, free ion activity in the fluid, or some other disturbance of the fluid/electrode capacitive layer. In such noisy applications, an analysis of the frequency spectrum reveals process noise that typically becomes significant below 15 Hz.

In some cases, the effects of process noise may be sharply reduced by elevating the coil drive frequency above the 15 Hz region. Coil drive mode is selectable between the standard 5 Hz and the noise-reducing 37 Hz.

### 10.4.1 Coil drive frequency

LOI menu path	<b>Detailed Setup → Additional Params → Coil Drive Freq</b>
Modbus host	77

This parameter changes the pulse rate of the magnetic coils.

#### 5 Hz

The standard coil drive frequency is 5 Hz, which is sufficient for nearly all applications.

#### 37 Hz

If the process fluid causes a noisy or unstable flow reading, increase the coil drive frequency to 37 Hz. If the 37 Hz mode is selected, perform the auto zero function for optimum performance.

#### Note

37 Hz coil drive frequency mode should not be used for sensors larger than 20-inch.

### 10.4.2 Auto zero

LOI menu path	<b>Diagnostics → Trims → Auto Zero</b>
Modbus coil	110

To ensure optimum accuracy when using 37 Hz coil drive mode, there is an auto zero function that should be initiated. When using 37 Hz coil drive mode it is important to zero the system for the specific application and installation.

Modbus coil value	Operation mode
0	Normal operating mode (default)
1	Perform auto zero

The auto zero procedure should be performed only under the following conditions:

- With the transmitter and sensor installed in their final positions. This procedure is not applicable on the bench.
- With the transmitter in 37 Hz coil drive mode. Never attempt this procedure with the transmitter in 5 Hz coil drive mode.
- With the sensor full of process fluid at zero flow.

These conditions should cause an output equivalent to zero flow.

Set the loop to manual if necessary and begin the auto zero procedure. The transmitter completes the procedure automatically in about 90 seconds. A clock symbol will appear in the lower right-hand corner of the display to indicate that the procedure is running.

#### Note

Failure to complete an auto zero may result in a flow velocity error of 5 to 10% at 1 ft/s (0.3 m/s). While the output level will be offset by the error, the repeatability will not be affected.

### 10.4.3 Other signal processing tools

The transmitter contains several advanced functions that can be used to stabilize erratic outputs caused by process noise. The signal processing menu contains this functionality. If the 37 Hz coil drive frequency has been set, and the output is still unstable, the damping and signal processing function should be used. It is important to set the coil drive frequency to 37 Hz to increase the flow sampling rate. The transmitter provides an easy and straightforward start-up, and also incorporates the capability to deal with difficult applications that have previously manifested themselves in a noisy output signal. In addition to selecting a higher coil drive frequency (37 Hz vs. 5 Hz) to isolate the flow signal from the process noise, the microprocessor can scrutinize each input based on three user-defined parameters to reject the noise specific to the application.

#### Operating mode

LOI menu path	<b>Detailed Setup → Signal Processing → Operating Mode</b>
Modbus register	79

The operating mode should be used only when the signal is noisy and gives an unstable output. Filter mode automatically uses 37 Hz coil drive mode and activates signal processing at the factory set default values. When using filter mode, perform an auto zero with no flow and a full sensor. Either of the parameters, coil drive mode or signal processing, may still be changed individually. Turning signal processing off or changing the coil drive frequency to 5 Hz will automatically change the operating mode from filter mode to normal mode. This software technique, known as signal processing, “qualifies” individual flow signals based on historic flow information and three user-definable parameters, plus an on/off control. These parameters are described below.

Register value	Operation mode
0	Normal mode (default)
1	Filter mode

#### Status

LOI menu path	<b>Detailed Setup → Signal Processing → Main Config DSP → Status</b>
Modbus register	78

Enable or disable the DSP capabilities. When ON is selected, the output is derived using a running average of the individual flow inputs. Signal processing is a software algorithm that examines the quality of the electrode signal against user-specified tolerances. The three parameters that make up signal processing (number of samples, maximum percent limit, and time limit) are described below.

Register value	Operating mode
0	DSP is turned OFF
1	DSP is turned ON

### Number of samples

LOI menu path	<b>Detailed Setup → Signal Processing → Main Config DSP → Samples</b>
Modbus register	80

The number of samples sets the amount of time that inputs are collected and used to calculate the average value. Each second is divided into tenths with the number of samples equaling the number of increments used to calculate the average. This parameter can be configured for an integer value between 1 and 125. The default value is 90 samples.

For example:

- A value of 1 averages the inputs over the past  $1/10$  second
- A value of 10 averages the inputs over the past 1 second
- A value of 100 averages the inputs over the past 10 seconds
- A value of 125 averages the inputs over the past 12.5 seconds

### Percent limit

LOI menu path	<b>Detailed Setup → Signal Processing → Main Config DSP → % Limit</b>
Modbus register	361, 362

This parameter will set the tolerance band on either side of the running average, referring to percent deviation from the average. Values within the limit are accepted while value outside the limit are scrutinized to determine if they are a noise spike or an actual flow change. This parameter can be configured for an integer value between 0 and 100 percent. The default value is 2 percent.

### Time limit

LOI menu path	<b>Detailed Setup → Signal Processing → Main Config DSP → Time Limit</b>
Modbus register	363, 364

The time limit parameter forces the output and running average values to the new value of an actual flow rate change that is outside the percent limit boundaries. It thereby limits response time to flow changes to the time limit value rather than the length of the running average. If the number of samples selected is 100, then the response time of the system is 10 seconds. In some cases this may be unacceptable. Setting the time limit forces the transmitter to clear the value of the running average and re-establish the output and average at the new flow rate once the time limit has elapsed. This parameter limits the response time added to the loop. A suggested time limit value of two seconds is a good starting point for most applicable process fluids. This parameter can be configured for a value between 0.6 and 256 seconds. The default value is 2 seconds.

## 10.5 Explanation of signal processing algorithm

An example plotting flow rate versus time is given below to help visualize the signal processing algorithm.

**Figure 10-1: Signal Processing Functionality**

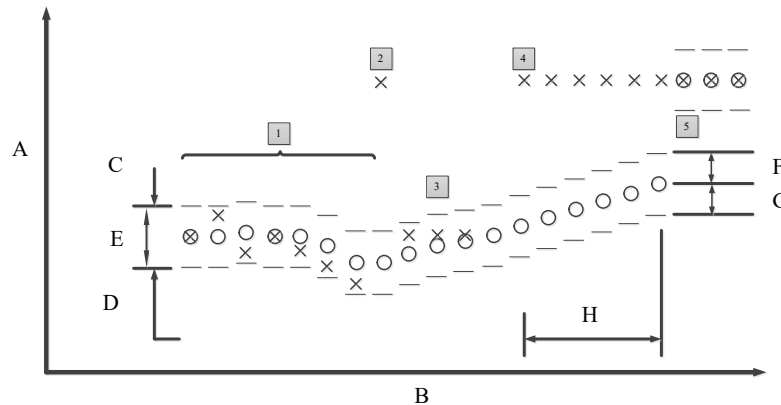

- A. Flow rate
- B. Time (10 samples = 1 second)
- C. Upper value
- D. Lower value
- E. Tolerance band
- F. Maximum percent limit
- G. Minimum percent limit
- H. Time limit

- X = Input flow signal from sensor
- O = Average flow signals and transmitter output, determined by the number of samples parameter
- Tolerance band, determined by the percent limit parameter
- Upper value = average flow + [(percent limit/100) average flow]
- Lower value = average flow - [(percent limit/100) average flow]

1. This scenario is that of a typical non-noisy flow. The input flow signal is within the percent limit tolerance band, therefore qualifying itself as a good input. In this case, the new input is added directly into the running average and is passed on as a part of the average value to the output.
2. This signal is outside the tolerance band and therefore is held in memory until the next input can be evaluated. The running average is provided as the output.
3. The previous signal currently held in memory is simply rejected as a noise spike since the next flow input signal is back within the tolerance band. This results in complete rejection of noise spikes rather than allowing them to be **averaged** with the good signals as occurs in the typical circuits.
4. As in number 2 above, the input is outside the tolerance band. This first signal is held in memory and compared to the next signal. The next signal is also outside the tolerance band (in the same direction), so the stored value is added to the running

average as the next input and the running average begins to slowly approach the new input level.

5. To avoid waiting for the slowly incrementing average value to catch up to the new level input, an algorithm is provided. This is the **time limit** parameter. The user can set this parameter to eliminate the slow ramping of the output toward the new input level.



# 11 Maintenance

## 11.1 Introduction

This section covers basic transmitter maintenance. Instructions and procedures in this section may require special precautions to ensure the safety of the personnel performing the operations. Read the following safety messages before performing any operation described in this section. Refer to these warnings when appropriate throughout this section.

## 11.2 Safety information

### ⚠ WARNING

Failure to follow these maintenance guidelines could result in death or serious injury.

- Installation and servicing instructions should be performed by qualified personnel only.
- Do not perform any servicing other than that contained in the operating instructions.
- Verify the operating environment of the sensor and transmitter is consistent with the appropriate hazardous area approval.
- Do not connect the transmitter to a non-Rosemount sensor that is located in an explosive atmosphere.
- Mishandling products exposed to a hazardous substance may result in death or serious injury.
- If the product being returned was exposed to a hazardous substance as defined by OSHA, a copy of the required Material Safety Data Sheet (MSDS) for each hazardous substance identified must be included with the returned goods.

## 11.3 Installing a LOI/Display

Figure 11-1: Installing a LOI/Display

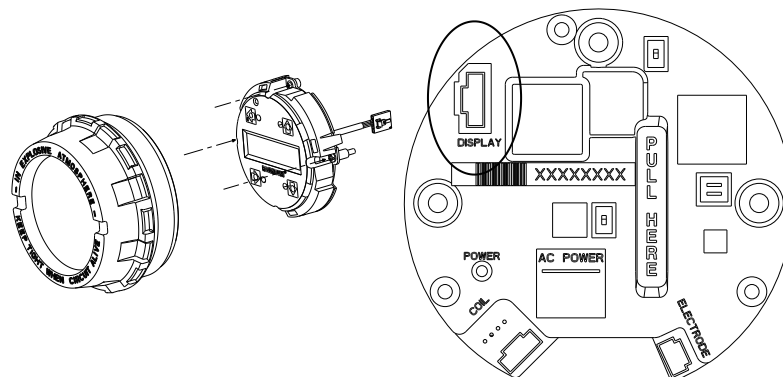

### Procedure

1. If the transmitter is installed in a control loop, secure the loop.

2. Remove power from the transmitter.
3. Remove the cover on the electronics compartment of the transmitter housing. If the cover has a cover jam screw, loosen it before removing the cover.  
See [Cover jam screw](#) for details on the cover jam screw.
4. On the electronics stack, locate the serial connection labeled **DISPLAY**.  
See [Figure 11-1](#).
5. Plug the serial connector from the back of the LOI/Display into the receptacle on the electronics stack.  
The LOI/Display can be rotated in 90 degree increments to provide the best viewing position. Rotate the LOI/Display to the desired orientation, taking care to not exceed 360 degrees of rotation. Exceeding 360 degrees of rotation could damage the LOI/Display cable and/or connector.
6. Once the serial connector is installed on the electronics stack, and the LOI/Display is oriented in the desired position, tighten the three mounting screws.
7. Install the extended cover with the glass viewing pane and tighten to metal-to-metal contact.  
If the cover has a cover jam screw, this must be tightened to comply with installation requirements. Return power to the transmitter and verify that it is functioning correctly and reporting the expected flow rate.
8. If installed in a control loop, return the loop to automatic control.

## 11.4 Replacing electronics stack

### Prerequisites

Make sure that the existing electronics stack is the same as the replacement (Revision 4) electronics stack. There are two ways to make sure:

- Look at the complete transmitter model number. Current (Revision 4) electronics are only compatible with Models 8732EM. If your transmitter model number as shown on the model number tag is not 8732EM, you cannot use a Revision 4 board stack.
- Visually inspect the existing and new electronics stacks to ensure that they are physically alike. The current (Revision 4) version of the stack has its electrical connections in different locations from the older versions. Both are shown in [Figure 11-2](#).

---

### Note

You must open the housing and expose the electronics stack to inspect it (see [Step 1](#) through [Step 5](#) below). Follow all applicable safety procedures and see [Powering the transmitter](#) for details on the covers.

---

Figure 11-2: Electronics Stack Identification



- A. Current (Revision 4) electronics stack.  
B. Old electronics stack.

### Procedure

1. If the transmitter is installed in a control loop, secure the loop.
2. Remove power from the transmitter.
3. Remove the LOI/Display-side cover of the transmitter.

### Note

See [Powering the transmitter](#) for details on the covers.

4. Remove the three screws that hold the LOI/Display to the electronics stack.
5. Carefully unplug the LOI/Display connector and remove and set aside the LOI/Display.
6. Carefully unplug the coil and electrode connectors.
7. Remove the three screws that secure the electronics stack into the housing.
8. Carefully pull out the electronics stack by the handle marked **PULL HERE**.
9. Remove the screws from the old electronics stack and insert them into the new electronics stack.
10. Hold the new electronics stack by the handle and carefully insert it into the housing, making certain that the screw holes and electrical connectors are in proper alignment to seat the stack.
11. Securely tighten the three electronics stack screws into the housing.
12. Plug in the coil and electrode connectors.
13. Replace the LOI/Display and refasten the three screws to secure it to the electronics stack.
14. Reinstall the LOI/Display-side cover of the transmitter and tighten it to ensure the housing is properly sealed to meet ingress protection requirements.
15. Return power to the transmitter and verify that it is functioning correctly and reporting the expected flow rate.
16. If installed in a control loop, return the loop to automatic control.

## 11.5 Replacing a socket module/terminal block

The socket module connects the sensor adapter to the transmitter. There are two versions of the socket module — one for integral mount transmitters and one for remote mount transmitters. The socket module is a replaceable component.

To remove the socket module, loosen the two mounting screws and pull up on the socket module from the base. When removing the socket module, do not pull on the wires. See [Figure 11-3](#).

**Figure 11-3: Socket Module Warning**

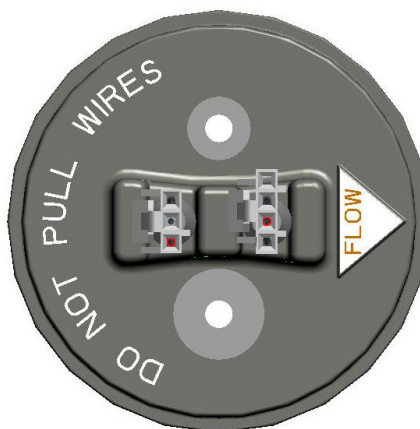

### 11.5.1 Replacing an integral mount socket module

#### Prerequisites

The integral mount socket module is shown in [Figure 11-4](#). To gain access to the socket module, the transmitter must be removed from the sensor adapter.

**Figure 11-4: Socket Module—Integral Mount**



## Removing an integral mount socket module

### Procedure

1. Disconnect power.
2. Remove electronics cover to gain access to the coil and electrode cables.
3. If the transmitter has a LOI/Display, it will need to be removed to gain access to the coil and electrode cables.
4. Disconnect the coil and electrode cables.
5. Remove the four transmitter mounting bolts.
6. Lift the transmitter off of the sensor adapter.
7. To remove the socket module, loosen the two mounting screws and pull up on the socket module from the base.
8. When removing the socket module, do not pull on the wires.

See [Figure 11-3](#).

## Installing an integral mount socket module

### Procedure

1. To insert a new integral mount socket module, press the base into its keyed position and tighten the two mounting screws.
2. The coil and electrode cables are fed through the bottom opening of the transmitter and plugged into the face of the electronics.
3. The coil and electrode cables are keyed so they will only fit into their dedicated location.
4. If the transmitter has a LOI/Display, it will need to be removed to access the coil and electrode ports.
5. Once the connections are made, the transmitter can be secured to the sensor adapter using the four mounting bolts.

## 11.5.2 Replacing a terminal block socket module

### Prerequisites

#### Note

This section only applies to sensors with Kx approval codes.

The terminal block socket module is shown in [Figure 11-5](#). To gain access to the socket module, remove the junction box from the sensor adapter.

Figure 11-5: Socket Module—Terminal Block

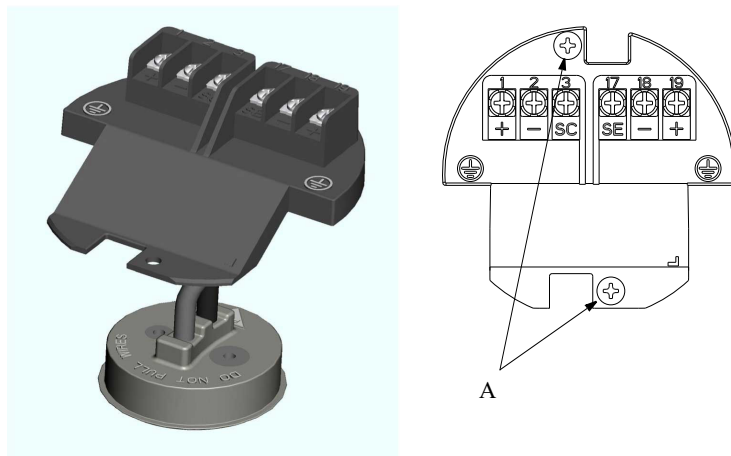

A. Mounting screws:

- 2X—standard
- 4X—with I.S. divider

## Removing a terminal block socket module

### Procedure

1. Disconnect power to the transmitter and the remote cabling connected to the terminal block.
2. Remove the junction box cover to gain access to the remote cabling.
3. To disconnect the terminal block from the junction box housing, remove the two mounting screws and the two divider mounting screws (if applicable).
4. Pull up on the terminal block to expose the socket module base.
5. To remove the socket module, loosen the two mounting screws and pull up on the socket module from the base.
6. When removing the socket module, do not pull on the wires.

See [Figure 11-3](#).

## Installing a terminal block socket module

### Procedure

1. Insert the new terminal block socket module, press the base into its keyed position, and tighten the two mounting screws.
2. Connect the terminal block to the junction box housing by tightening the two mounting screws.  
Install the divider with the two mounting screws if applicable.
3. Reconnect remote cabling and power and replace junction box cover.

## 11.5.3 Replacing a terminal block with amp clips

### Note

This section applies only to sensors with Nx approval codes or no hazardous area approval code for use in ordinary locations.

**Figure 11-6: Terminal block with amp clips**

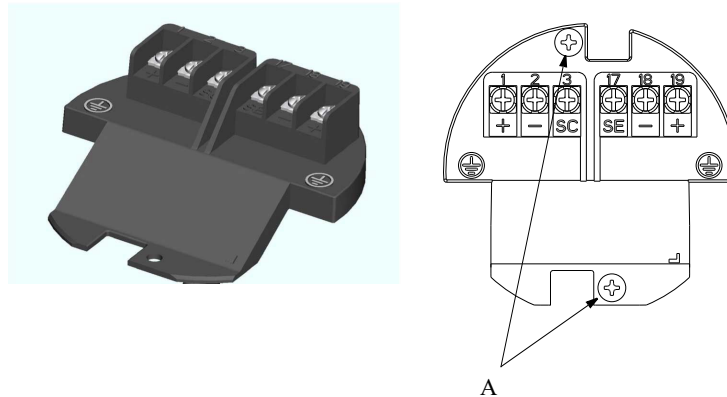

A. *Mounting screws:*

- 2X—standard
- 4X—with I.S. divider

## Removing a terminal block

### Procedure

1. Disconnect power to the transmitter.
2. Remove the junction box cover on the sensor to gain access to the remote cabling and disconnect the remote cabling connected to the terminal block.
3. To disconnect the terminal block from the junction box housing, remove the two mounting screws and the two divider mounting screws (if applicable).
4. Pull up on the terminal block to expose the connecting wires.
5. To remove the terminal block, unclip both wire connectors.

## Installing a terminal block

### Procedure

1. Clip the connecting wires to the back of the terminal block, the clips are different sizes and must be connected to their matching receptacle.
2. Connect the terminal block to the junction box housing by tightening the two mounting screws. Install the divider with the two mounting screws if applicable.
3. Reconnect remote cabling, replace the junction box cover on the sensor, and connect power.

## 11.6 Trims

LOI menu path	<b>Diagnostics → Trims</b>
---------------	----------------------------

Trims are used to calibrate the transmitter, re-zero the transmitter, and calibrate the transmitter with another manufacturer's sensor. Proceed with caution whenever performing a trim function.

### 11.6.1 Digital trim

LOI menu path	<b>Diagnostics → Trims → Digital Trim</b>
Modbus coil	109

Digital trim is the function by which the factory calibrates the transmitter. This procedure is rarely needed by users. It is only necessary if the transmitter is suspected to be no longer accurate. A Rosemount 8714D Calibration Standard is required to complete a digital trim. Attempting a digital trim without a Rosemount 8714D Calibration Standard may result in an inaccurate transmitter or an error message. The digital trim must be performed with the coil drive mode set to 5Hz and with a nominal sensor calibration number stored in the memory.

#### Note

Attempting a digital trim without a Rosemount 8714D Calibration Standard may result in an inaccurate transmitter, or a **DIGITAL TRIM FAILURE** message may appear. If this message occurs, no values were changed in the transmitter. Simply cycle power on the transmitter to clear the message.

Modbus coil value	Operating mode
0	Normal operating mode
1	Perform digital trim

To simulate a nominal sensor with the Rosemount 8714D Calibration Standard, change/verify the following parameters in the transmitter:

- Calibration Number-1000015010000000
- Units-ft/s
- PV URV-20mA = 30.00 ft/s
- PV LRV-4mA = 0 ft/s
- Coil Drive Frequency-5Hz

Before changing any of the configuration parameters, be sure to record the original values so that the transmitter can be returned to the original configuration prior to being placed back into operation. Failure to return the settings to the original configuration will result in incorrect flow and totalizer readings.

The instructions for changing the calibration number, units, PV URV, and PV LRV are located in [Basic setup](#). Instructions for changing the coil drive frequency can be found on [Coil drive frequency](#).

Set the loop to manual (if necessary) and then complete the following steps:

#### Procedure

1. Power down the transmitter.



2. Connect the transmitter to a Rosemount 8714D Calibration Standard.
3. Power up the transmitter with the Rosemount 8714D connected and read the flow rate.

The electronics need about a 5-minute warm-up time to stabilize.

4. Set the 8714D Calibration Standard to the 30 ft/s (9.1 m/s) setting.
5. The flow rate reading after warm-up should be between 29.97 (9.1 m/s) and 30.03 ft/s (9.2 m/s).
6. If the reading is within the range, return the transmitter to the original configuration parameters.
7. If the reading is not within this range, initiate a digital trim.

The digital trim takes about 90 seconds to complete. No transmitter adjustments are required.

## 11.6.2 Universal trim

LOI menu path	<b>Diagnostics → Trims → Universal Trim</b>
Modbus coil	111

The universal auto trim function enables the transmitter to calibrate sensors that were not calibrated at the factory. The function is activated as one step in a procedure known as in-process calibration. If a sensor has a 16-digit calibration number, in-process calibration is not required. If it does not, or if the sensor is made by another manufacturer, complete the following steps for in-process calibration. Refer to [Implementing a Universal Transmitter](#).

Modbus coil value	Operating mode
0	Normal operating mode
1	Perform universal trim

### Procedure

1. Determine the flow rate of the process fluid in the sensor.

#### Note

The flow rate in the line can be determined by using another sensor in the line, by counting the revolutions of a centrifugal pump, or by performing a bucket test to determine how fast a given volume is filled by the process fluid.

2. Write the flow rate to Modbus register 331.
3. Initiate the universal trim by writing 1 to Modbus coil 111.

When the routine is completed, the sensor is ready for use.

The flow rate written to Modbus register 331 will be set back to the default value of 0.

## 11.7 Review

LOI menu path	<b>Device Setup → Review</b>
---------------	------------------------------

The transmitter includes a capability to review the configuration variable settings.

The flowmeter configuration parameters set at the factory should be reviewed to ensure accuracy and compatibility with the particular application of the flowmeter.

---

**Note**

If the LOI is used to review variables, each variable must be accessed as if changing its setting. The value displayed on the LOI screen is the configured value of the variable.

---

# 12 Troubleshooting

## 12.1 Introduction

This section covers basic transmitter and sensor troubleshooting. Problems in the magnetic flow meter system are usually indicated by incorrect output readings from the system, error messages, or failed tests. Consider all sources when identifying a problem in the system. If the problem persists, consult an Emerson Flow Representative to determine if the material should be returned to the factory. Emerson offers several diagnostics that aid in the troubleshooting process. Instructions and procedures in this section may require special precautions to ensure the safety of the personnel performing the operations. Read the following safety messages before performing any operation described in this section. Refer to these warnings when appropriate throughout this section.

The transmitter performs self-diagnostics on the entire magnetic flow meter system: the transmitter, the sensor, and the interconnecting wiring. By sequentially troubleshooting each individual piece of the system, it becomes easier to identify the problem and make the appropriate adjustments.

If there are problems with a new installation, see [Installation check and guide](#) below for a quick guide to solve the most common problems. For existing installations, [Table 12-7](#) lists the most common problems and corrective actions.

## 12.2 Safety information

### **⚠ WARNING**

Failure to follow these troubleshooting guidelines could result in death or serious injury.

- Installation and servicing instructions should be performed by qualified personnel only.
- Do not perform any servicing other than that contained in the operating instructions.
- Verify that the operating environment of the sensor and transmitter is consistent with the appropriate hazardous area approval.
- Do not connect the transmitter to a non-Rosemount sensor that is located in an explosive atmosphere.
- Mishandling products exposed to a hazardous substance may result in death or serious injury.
- If the product being returned was exposed to a hazardous substance as defined by OSHA, a copy of the required Material Safety Data Sheet (MSDS) for each hazardous substance identified must be included with the returned goods.

## 12.3 Installation check and guide

Use this guide to check new installations of Rosemount magnetic flowmeter systems that appear to malfunction.

## 12.3.1 Transmitter

### Checking the transmitter before applying power

#### Prerequisites

Before applying power to the magnetic flowmeter system, make the following transmitter checks:

#### Procedure

1. Record the transmitter model number and serial number.
2. Visually inspect the transmitter for any damage including the terminal block.
3. Verify the proper wiring connections have been made for the power and outputs.

### Checking the transmitter after applying power

#### Prerequisites

Apply power to the magnetic flowmeter system before making the following transmitter checks:

#### Procedure

1. Check for an active error message or status alert. Refer to [Diagnostic messages](#).
2. Verify the correct sensor calibration number is entered in the transmitter.  
The calibration number is listed on the sensor nameplate.
3. Verify the correct sensor line size is entered in the transmitter.  
The line size value is listed on the sensor nameplate.
4. If desired, use a Rosemount 8714D Calibration Standard to verify the transmitter calibration.

## 12.3.2 Sensor

#### Prerequisites

Be sure that power to magnetic flowmeter system is removed before beginning the following sensor checks:

#### Procedure

1. Record the sensor model number and serial number.
2. Visually inspect the sensor for any damage including inside the remote junction box, if applicable.
3. For horizontal flow installations, ensure that the electrodes remain covered by process fluid.  
For vertical or inclined installations, ensure that the process fluid is flowing up into the sensor to keep the electrodes covered by process fluid.
4. Verify the flow arrow is pointing in the same direction as forward flow.
5. Ensure the grounding straps on the sensor are connected to grounding rings, lining protectors, or the adjacent pipe flanges. Improper grounding will cause erratic operation of the system.

Sensors with a ground electrode will not require the grounding straps to be connected.

### 12.3.3 Remote wiring

#### Procedure

1. The electrode signal and coil drive wires must be separate cables unless Rosemount specified combo cable is used.  
See [Sensor to transmitter wiring](#).
2. The electrode signal wire and coil drive wire must be twisted shielded cable. Rosemount recommends 20 AWG twisted shielded cable for the electrode signal and 14 AWG twisted shielded cable for the coil drive.  
See [Sensor to transmitter wiring](#).
3. See [Product certifications](#) regarding wiring installation requirements.
4. See [Wiring Diagrams](#) for component wiring.
5. Verify there is minimal exposed wiring and shielding.  
Less than 1 inch (25 mm) is recommended.
6. Verify that the single conduit that houses both the electrode signal and coil drive cables do not contain any other wires, including wires from other magmeters.

---

#### Note

For installations requiring intrinsically safe electrodes, the signal and coil drive cables must be run in individual conduits.

---

### 12.3.4 Process fluid

#### Procedure

1. The process fluid should have a minimum conductivity of 5 microSiemens/cm (5 micro mhos/cm).
2. The process fluid must be free of air and gas.
3. The sensor must be full of process fluid.
4. The process fluid must be compatible with the wetted materials - liner, electrodes, ground rings, and lining protectors.  
Refer to the *Rosemount™ Magnetic Flowmeter Material Selection Guide (00816-0100-3033)* Technical Note for details.
5. If the process is electrolytic or has cathodic protection, refer to the *Installation and Grounding of Magmeters in Typical and Special Applications (00840-2400-4727)* Technical Note for special installation requirements.

## 12.4 Diagnostic messages

Problems in the magnetic flowmeter system are usually indicated by incorrect output readings from the system, error messages, or failed tests. Consider all sources in identifying a problem in the system.

**Table 12-1: Modbus communication diagnostic messages**

Error message	Potential cause	Corrective action
I/O Processor Failure	ROM failure	<ul style="list-style-type: none"> <li>Use LOI to re-set Modbus communication.</li> <li>Cycle power to transmitter.</li> <li>Replace electronics.</li> </ul>
	Checksum failure	
	RAM failure	
	Stack failure	
	Register failure	
Modbus Non-volatile Memory Error	The non-volatile memory on the Modbus processor is corrupted.	<ul style="list-style-type: none"> <li>Cycle power.</li> <li>Replace electronics.</li> </ul>
Modbus in Listen-Only Mode	The listen-only mode was activated in the host or through the LOI.	<ul style="list-style-type: none"> <li>Use host system or LOI to turn off listen-only mode.</li> </ul>
I/O Processor Comm Failure	No communication with the Modbus processor for 10 seconds	<ul style="list-style-type: none"> <li>Use LOI to re-set Modbus communication.</li> </ul>
	Modbus network error	<ul style="list-style-type: none"> <li>Verify all wiring is correct and terminations are sound.</li> <li>Cycle power.</li> <li>Replace electronics.</li> </ul>
Invalid parameter error (not found on LOI)	Trying to complete a trim or test with an uninitialized value for a test parameter	<ul style="list-style-type: none"> <li>Consult section of the manual for applicable trim or test.</li> <li>Verify all parameters are configured.</li> </ul>

**Table 12-2: Basic Diagnostic Messages**

Error message	Potential cause	Corrective action
Empty Pipe	Empty pipe	None - message will clear when pipe is full.
	Wiring error	Check that wiring matches appropriate wiring diagrams.
	Electrode error	Perform sensor tests - see <a href="#">Installed sensor tests</a> .
	Conductivity less than 5 microSiemens per cm	Increase conductivity to greater than or equal to 5 microSiemens per cm.
	Intermittent diagnostic	Adjust tuning of empty pipe parameters - see <a href="#">Troubleshooting empty pipe</a> .
Coil Open Circuit	Improper wiring	Check coil drive wiring and sensor coils. Perform sensor tests - see <a href="#">Installed sensor tests</a> .
	Other manufacturer's sensor	Change coil current to 75 mA - set calibration numbers to 10000550100000030.
		Perform a universal auto-trim to select the proper coil current.
	Electronics board failure	Replace electronics stack.
Coil circuit open fuse	Replace the sensor.	
Auto Zero Failure	Flow is not set to zero	Force flow to zero, perform auto zero trim.
	Unshielded cable in use	Change wire to shielded cable.
	Moisture problems	See <a href="#">Installed sensor tests</a> .

**Table 12-2: Basic Diagnostic Messages (continued)**

Error message	Potential cause	Corrective action
Auto-Trim Failure	No flow in pipe while performing Universal Auto Trim	Establish a known flow rate, and perform universal auto-trim calibration.
	Wiring error	Check that wiring matches appropriate wiring diagrams - see <a href="#">Implementing a Universal Transmitter</a> .
	Flow rate is changing in pipe while performing Universal Auto-Trim routine.	Establish a constant flow rate, and perform universal auto-trim calibration.
	Flow rate through sensor is significantly different than value entered during Universal Auto-Trim routine.	Verify flow in sensor and perform universal auto-trim calibration.
	Incorrect calibration number entered into transmitter for Universal Auto-Trim routine	Replace sensor calibration number with 1000005010000000.
	Wrong sensor size selected	Correct sensor size setting - see <a href="#">Basic setup</a> .
	Sensor failure	Perform sensor tests - see <a href="#">Installed sensor tests</a> .
Electronics Failure	Electronics self check failure	Cycle power to see if diagnostic message clears.
		Replace Electronics stack.
Electronics Temp Fail	Ambient temperature exceeded the electronics temperature limits	Move transmitter to a location with an ambient temperature range of -40 to 140 °F (-40 to 60 °C).
Reverse Flow	Electrode or coil wires reverse	Verify wiring between sensor and transmitter.
	Flow is reverse	Turn ON Reverse Flow Enable to read flow.
	Sensor installed backwards	Install sensor correctly, or switch either the electrode wires (18 and 19) or the coil wires (1 and 2).
PZR Activated (Positive Zero Return)	External voltage applied to terminals 5 and 6	Remove voltage to turn PZR off.
Pulse Out of Range	The transmitter is trying to generate a frequency greater than allowed.	Standard pulse - increase pulse scaling to prevent pulse output from exceeding 11,000 Hz.
		Intrinsically safe pulse - Increase pulse scaling to prevent pulse output from exceeding 5,500 Hz.
		Pulse output is in fixed pulse mode and is trying to generate a frequency greater than the pulse width can support - see <a href="#">Pulse output</a> .
		Verify the sensor calibration number and line size are correctly entered in the electronics.
Flow rate > 43 ft/sec	Flow rate is greater than 43 ft/sec.	Lower flow velocity, increase pipe diameter.
	Improper wiring	Check coil drive wiring and sensor coils.
		Perform sensor tests - see <a href="#">Installed sensor tests</a> .
Digital Trim Failure (Cycle power to clear messages, no changes were made)	The calibrator (8714B/C/D) is not connected properly.	Review calibrator connections.
	Incorrect calibration number entered into transmitter	Replace sensor calibration number with 1000015010000000.
	Calibrator is not set to 30 FPS.	Change calibrator setting to 30 FPS.

**Table 12-2: Basic Diagnostic Messages (continued)**

Error message	Potential cause	Corrective action
	Bad calibrator or calibrator cable	Replace calibrator and/or calibrator cable.
Coil Over Current	Improper wiring	Check coil drive wiring and sensor coils. Perform sensor tests - see <a href="#">Installed sensor tests</a> .
	Transmitter failure	Replace the electronics stack.
Coil Power Limit	Improper wiring	Check coil drive wiring and sensor coils. Perform sensor tests - see <a href="#">Installed sensor tests</a> .
	Incorrect calibration number	Verify configured calibration number matches sensor tag.
	Transmitter connected to other manufacturer's sensor	Change coil current to 75 mA - set calibration number to 10000550100000030. Perform a universal auto-trim to select the proper coil current.
	Coil drive frequency set to 37 Hz	Sensor may not be compatible with 37 Hz. Switch coil drive frequency to 5 Hz.
	Sensor failure	Perform sensor tests - see <a href="#">Installed sensor tests</a> .
Electrode Saturation	Improper wiring	See <a href="#">Wiring</a> .
	Improper process reference	See <a href="#">Process reference connection</a> .
	Improper earth grounding	Verify earth ground connections - see <a href="#">Wiring</a> .
	Application requires special transmitter	Replace transmitter with transmitter that includes special option F0100.
LOI Comm Error/LOI Lost Sync	Electrical noise	Verify earth ground connections - see <a href="#">Wiring</a> .
	Extreme vibration	Relocate transmitter.
	Transmitter failure	Cycle power. If error returns, replace board stack.
LOI Key Stuck	Debris on the LOI glass	Clean LOI glass of any debris.
	Holding LOI key for more than 60 seconds	Lock LOI to prevent unintentional configuration changes - see <a href="#">Display lock</a> .
	High levels of electrical noise	Move transmitter away from other electrical equipment or cables.
	Faulty LOI	Replace LOI.

**Table 12-3: Advanced Process Diagnostic Messages**

Error message	Potential cause	Corrective action
Grounding/Wiring Fault	Improper installation of wiring	See <a href="#">Wiring</a> .
	Coil/electrode shield not connected	See <a href="#">Wiring</a> .
	Improper process grounding	See <a href="#">Process reference connection</a> .
	Faulty ground connection	Check wiring for corrosion, moisture in the terminal block -see <a href="#">Process reference connection</a> .
	Sensor not full	Verify sensor is full. Enable empty pipe detection.
High Process Noise	Slurry flows - mining/pulp stock	Decrease the flow rate below 10 ft/s (3 m/s).



**Table 12-3: Advanced Process Diagnostic Messages (continued)**

Error message	Potential cause	Corrective action
		Complete the possible solutions listed under <a href="#">Troubleshooting high process noise</a> .
	Chemical additives upstream of the sensor	Move injection point downstream of the sensor or move the sensor to a new location.
		Complete the possible solutions listed under <a href="#">Troubleshooting high process noise</a> .
	Electrode not compatible with the process fluid	Refer to the <i>Rosemount™ Magnetic Flowmeter Material Selection Guide (00816-0100-3033)</i> .
	Gas/air in line	Move the sensor to another location in the process line to ensure that it is full under all conditions.
	Electrode coating	Enable coated electrode detection diagnostic.
		Use bullet-nose electrodes.
		Downsize sensor to increase flow rate above 3 ft/s (1 m/s).
		Periodically clean sensor.
	Styrofoam or other insulating particles	Complete the possible solutions listed under <a href="#">Troubleshooting high process noise</a> .
Consult factory.		
Low conductivity fluids (below 10 microsiemens/cm)	Trim electrode and coil wires - see <a href="#">Sensor Installation</a> .	
	Use integral mount transmitter.	
	Set coil drive frequency to 37 Hz.	
Electrode Coating Level 1	Coating is starting to buildup on electrode and interfering with measurement signal.	Schedule maintenance to clean electrode
		Use bullet nose electrodes.
		Downsize sensor to increase flow rate above 3 ft/s (1 ms).
	Process fluid conductivity has changed.	Verify process fluid conductivity.
Electrode Coating Level 2	Coating has built-up on electrode and is interfering with measurement signal.	Schedule maintenance to clean electrode.
		Use bullet nose electrodes.
		Downsize sensor to increase flow rate above 3 ft/s (1 ms).
	Process fluid conductivity has changed.	Verify process fluid conductivity.

**Table 12-4: Advanced Meter Verification Messages**

Error message	Potential cause	Corrective action
Meter Ver Failed	Transmitter calibration verification test failed	Verify pass/fail criteria.
		Rerun Smart™ Meter Verification under no flow conditions.
		Verify calibration using 8714D Calibration Standard.
		Perform digital trim.
		Replace electronics board.

**Table 12-4: Advanced Meter Verification Messages (continued)**

Error message	Potential cause	Corrective action
	Sensor calibration test failed	Verify pass/fail criteria.
		Rerun Smart Meter Verification.
		Perform sensor tests - see <a href="#">Installed sensor tests</a> .
	Sensor coil circuit test failed	Verify pass/fail criteria.
		Rerun Smart Meter Verification.
		Perform sensor tests - see <a href="#">Installed sensor tests</a> .
	Sensor electrode circuit test failed	Verify electrode resistance has a baseline (signature) value from a full pipe baseline.
		Verify test condition was selected properly.
		Verify pass/fail criteria.
		Rerun Smart Meter Verification.
		Perform sensor tests - see <a href="#">Installed sensor tests</a> .
	Continuous Meter Verification Error	Transmitter calibration verification test failed
Run manual Smart Meter Verification under no flow conditions.		
Verify calibration using 8714D Calibration Standard.		
Perform digital trim.		
Replace electronics stack.		
Sensor calibration test failed		Run manual Smart Meter Verification.
		Perform sensor tests - see <a href="#">Installed sensor tests</a> .
Sensor coil circuit test failed		Run manual Smart Meter Verification.
		Perform sensor tests - see <a href="#">Installed sensor tests</a> .
Sensor electrode circuit test failed		Run manual Smart Meter Verification.
		Perform sensor tests - see <a href="#">Installed sensor tests</a> .
		Verify electrode resistance has a signature value from a full pipe baseline.
Simulated Velocity Out of Spec	Unstable flow rate during the verification test or noisy process	Run manual transmitter verification test with no flow and a full pipe.
	Transmitter drift or faulty electronics	Verify transmitter electronics with 8714D Calibration Standard. The dial on the 8714D should be set to 30 ft/s (9.14 m/s). The transmitter should be set up with the nominal calibration number (1000015010000000) and 5 Hz coil drive frequency.
		Perform an electronics trim using the 8714D.
		If the electronics trim doesn't correct the issue, replace the electronics.
Coil Resistance Out of Spec	Moisture in the terminal block of the sensor or shorted coil	Perform sensor tests - see <a href="#">Installed sensor tests</a> .
		If the problem persists, replace the sensor.
Coil Signature Out of Spec	Moisture in the terminal block of the sensor or shorted coil	Perform sensor tests - see <a href="#">Installed sensor tests</a> .
		If the problem persists, replace the sensor.

**Table 12-4: Advanced Meter Verification Messages (continued)**

Error message	Potential cause	Corrective action
	Calibration shift caused by heat cycling or vibration	Perform sensor tests - see <a href="#">Installed sensor tests</a> .
		If the problem persists, replace the sensor.
Electrode Resistance Out of Spec	Moisture in the terminal block of the sensor	Perform sensor tests - see <a href="#">Installed sensor tests</a> .
		If the problem persists, replace the sensor.
	Electrode coating	Enable coated electrode detection diagnostic.
		Use bullet-nose electrodes.
		Downsize sensor to increases flowrate above 3 ft/s (1 m/s).
		Periodically clean sensor.
Shorted electrodes	Perform sensor tests - see <a href="#">Installed sensor tests</a> .	
	If the problem persists, replace the sensor.	

### 12.4.1 Troubleshooting empty pipe

If empty pipe detection is unexpected:

**Procedure**

1. Verify the sensor is full.
2. Verify the sensor has not been installed with a measurement electrode at the top of the pipe.
3. Decrease the sensitivity by setting the empty pipe trigger level to a value of at least 20 counts above the empty pipe value read with a full pipe.
4. Decrease the sensitivity by increasing the empty pipe counts to compensate for process noise. The empty pipe counts is the number of consecutive empty pipe value readings above the empty pipe trigger level required to set the empty pipe diagnostic. The count range is 2-50, factory default set at 5.
5. Increase process fluid conductivity above 5 microsiemens/cm.
6. Properly connect the wiring between the sensor and the transmitter.
7. Perform the sensor electrical resistance tests. For more detailed information, consult [Installed sensor tests](#).

### 12.4.2 Troubleshooting ground/wiring fault

If transmitter detects high levels (greater than 5mV) 50/60 Hz noise caused by improper wiring or poor process grounding:

**Procedure**

1. Verify the transmitter is earth grounded.
2. Connect ground rings, grounding electrode, lining protector, or grounding straps. Grounding diagrams can be found in [Process reference connection](#).
3. Verify the sensor is full.
4. Verify wiring between sensor and transmitter is prepared properly. Shielding should be stripped back less than 1 inch (25 mm).
5. Use separate shielded twisted pairs for wiring between sensor and transmitter.

6. Properly connect the wiring between the sensor and the transmitter. Corresponding terminal block numbers in the sensor and transmitter must be connected.

## 12.4.3 Troubleshooting high process noise

---

### Note

In applications where very high levels of noise are a concern, it is recommended that a dual-calibrated Rosemount High-Signal 8707 sensor be used. These sensors can be calibrated to run at lower coil drive current supplied by the standard Rosemount transmitters, but can also be upgraded by changing to the 8712H High-Signal transmitter.

---

### Note

For more information about process noise, see [Process noise profiles](#).

---

### 1/f noise

This type of noise can be mitigated by switching to the 37 Hz coil drive setting.

### Spike noise

The type of noise can be mitigated by switching to the 37 Hz coil drive setting.

### White noise

This type of noise can be mitigated by switching to the 37 Hz coil drive setting.

## Noise ratio less than 25 in 5 Hz coil drive frequency mode

The transmitter detected high levels of process noise. If the signal to noise ratio is less than 25 in 5 Hz coil drive frequency mode, proceed with the following steps:

### Procedure

1. Increase transmitter coil drive frequency mode to 37 Hz (refer to [Coil drive frequency](#) and, if possible, perform auto zero function. See [Auto zero](#)).
2. Verify sensor is electrically connected to the process with process reference electrode, grounding rings with grounding straps, or lining protector with grounding straps.
3. If possible, redirect chemical additions downstream of the magmeter.
4. Verify process fluid conductivity is above 5 microSiemens/cm.

## Noise ratio less than less than 25 in 37 Hz coil drive frequency mode

If the signal to noise ratio is less than 25 in 37 Hz coil drive frequency mode, see [Digital Signal Processing](#).

## 12.4.4 Troubleshooting coated electrode detection

If an electrode coating is detected, use the following table to determine the appropriate course of action.

**Table 12-5: Troubleshooting the Electrode Coating Diagnostic**

Error message	Potential causes of error	Steps to correct
Electrode Coating Level 1	<ul style="list-style-type: none"> <li>Insulating coating is starting to build up on the electrode and may interfere with the flow measurement signal.</li> <li>Process fluid conductivity has decreased to a level close to operational limits of the meter.</li> </ul>	<ul style="list-style-type: none"> <li>Verify process fluid conductivity.</li> <li>Schedule maintenance to clean the electrodes.</li> <li>Use bullet nose electrodes.</li> <li>Replace the meter with a smaller diameter meter to increase the flow velocity to above 3 ft/s (1 m/s).</li> </ul>
Electrode Coating Level 2	<ul style="list-style-type: none"> <li>Insulating coating has built up on the electrodes and is interfering with the flow measurement signal.</li> <li>Process fluid conductivity has decreased to a level below the operational limits of the meter.</li> </ul>	<ul style="list-style-type: none"> <li>Verify process fluid conductivity.</li> <li>Schedule maintenance to clean the electrodes.</li> <li>Use bullet nose electrodes.</li> <li>Replace the meter with a smaller diameter meter to increase the flow velocity to above 3 ft/s (1 m/s).</li> </ul>

## 12.4.5 Troubleshooting the Smart Meter Verification test

If the Smart Meter Verification test fails, use the following table to determine the appropriate course of action. Begin by reviewing the Smart Meter Verification results to determine the specific test that failed.

**Table 12-6: Troubleshooting the Smart Meter Verification diagnostic**

Test	Potential cause	Corrective action
Transmitter Verification Test	<ul style="list-style-type: none"> <li>Unstable flow reading during the test</li> <li>Noise in the process</li> <li>Transmitter drift</li> <li>Faulty electronics</li> </ul>	<ul style="list-style-type: none"> <li>Rerun Smart Meter Verification under No Flow conditions.</li> <li>Check the transmitter calibration with the 8714D Calibration Standard.</li> <li>Perform a digital trim.</li> <li>Contact an Emerson Flow representative.</li> </ul>
Sensor Calibration Verification	<ul style="list-style-type: none"> <li>Moisture in the sensor terminal block</li> <li>Calibration shift caused by heat cycling or vibration</li> </ul>	<ul style="list-style-type: none"> <li>Rerun Smart Meter Verification.</li> <li>Perform the sensor checks detailed in <a href="#">Sensor troubleshooting</a>.</li> <li>Remove the sensor and send back for evaluation and / or recalibration.</li> </ul>
Coil Circuit Health	<ul style="list-style-type: none"> <li>Moisture in the sensor terminal block</li> <li>Shorted Coil</li> <li>High temperature application</li> <li>Long remote cable length</li> </ul>	<ul style="list-style-type: none"> <li>Retake sensor baseline at operating temperature.</li> </ul>

**Table 12-6: Troubleshooting the Smart Meter Verification diagnostic (continued)**

Test	Potential cause	Corrective action
Electrode Circuit Health	<ul style="list-style-type: none"> <li>• Electrode resistance baseline was not taken after installation</li> <li>• Test condition was not selected properly</li> <li>• Moisture in the sensor terminal block</li> <li>• Coated electrodes</li> <li>• Shorted electrodes</li> </ul>	

## 12.5 Basic troubleshooting

When troubleshooting a magmeter, it is important to identify the issue. below provides common symptoms displayed by a magmeter that is not functioning properly. This table provides potential causes and suggested corrective actions for each symptom.

**Table 12-7: Common magmeter issue**

Symptom	Electronics failure	Corrective action
Status Is bad	<ul style="list-style-type: none"> <li>• Electronics failure</li> </ul>	<ul style="list-style-type: none"> <li>• Cycle power.</li> <li>• If status is still bad, verify transmitter operation with an 8714 D Calibration Standard.</li> <li>• Replace the electronics stack.</li> </ul>
	<ul style="list-style-type: none"> <li>• Open coil circuit</li> </ul>	<ul style="list-style-type: none"> <li>• Check coil drive circuit connections at the sensor and at the transmitter.</li> </ul>
	<ul style="list-style-type: none"> <li>• Coil power or coil current is over limit.</li> </ul>	<ul style="list-style-type: none"> <li>• Check coil drive circuit connections at the sensor and at the transmitter.</li> <li>• Cycle power.</li> <li>• If status is still bad, verify transmitter operation with an 8714D Calibration Standard.</li> <li>• Replace the electronics stack.</li> </ul>
	<ul style="list-style-type: none"> <li>• Connected to incompatible sensor</li> </ul>	<ul style="list-style-type: none"> <li>• See <a href="#">Implementing a Universal Transmitter</a>.</li> </ul>
	<ul style="list-style-type: none"> <li>• Communication parameter mismatch</li> </ul>	<ul style="list-style-type: none"> <li>• Verify Modbus communication parameters in the transmitter match the communication parameters in the host system.</li> </ul>
Pulse output at zero, regardless of flow	<ul style="list-style-type: none"> <li>• Wiring error</li> </ul>	<ul style="list-style-type: none"> <li>• Check pulse output wiring at terminals 3 and 4. Refer to wiring diagram for pulse counter and pulse output. See <a href="#">Power and I/O terminal blocks</a>.</li> </ul>
	<ul style="list-style-type: none"> <li>• PZR activated</li> </ul>	<ul style="list-style-type: none"> <li>• Remove signal at terminals 5 and 6 to deactivate the PZR.</li> </ul>

**Table 12-7: Common magmeter issue (continued)**

Symptom	Electronics failure	Corrective action
	<ul style="list-style-type: none"> <li>No power to transmitter</li> </ul>	<ul style="list-style-type: none"> <li>Check pulse output wiring at terminals 3 and 4. Refer to wiring diagram for pulse counter and pulse output.</li> <li>Power the transmitter.</li> </ul>
	<ul style="list-style-type: none"> <li>Reverse flow</li> </ul>	<ul style="list-style-type: none"> <li>Enable Reverse Flow function.</li> </ul>
	<ul style="list-style-type: none"> <li>Electronics failure</li> </ul>	<ul style="list-style-type: none"> <li>Verify transmitter operation with an 8714D Calibration Standard.</li> <li>Replace the electronics stack.</li> </ul>
	<ul style="list-style-type: none"> <li>Pulse output incorrectly configured</li> </ul>	<ul style="list-style-type: none"> <li>Review configuration and correct as necessary.</li> </ul>
Error Messages on LOI	<ul style="list-style-type: none"> <li>Many possible causes depending upon the message</li> </ul>	<ul style="list-style-type: none"> <li>See <a href="#">Table 12-2</a>, <a href="#">Table 12-3</a>, and <a href="#">Table 12-4</a> for the LOI messages.</li> </ul>
Discrete input does not register	<ul style="list-style-type: none"> <li>Input signal does not provide enough counts</li> </ul>	<ul style="list-style-type: none"> <li>Verify the discrete input provided meets the requirements in <a href="#">Power and I/O terminal blocks</a>.</li> </ul>
Reading does not appear to be within rated accuracy	<ul style="list-style-type: none"> <li>Transmitter, control system, or other receiving device not configured properly</li> </ul>	<ul style="list-style-type: none"> <li>Check all configuration variables for the transmitter, sensor, communicator, and/or control system.</li> <li>Check these other transmitter settings:                             <ul style="list-style-type: none"> <li>— Sensor calibration number</li> <li>— Units</li> <li>— Line size</li> </ul> </li> </ul>
	<ul style="list-style-type: none"> <li>Electrode Coating</li> </ul>	<ul style="list-style-type: none"> <li>Enable Coated Electrode Detection diagnostic.</li> <li>Use bullet-nose electrodes.</li> <li>Downsize sensor to increase flow rate above 3 ft/s.</li> <li>Periodically clean sensor.</li> </ul>
	<ul style="list-style-type: none"> <li>Gas/air in line</li> </ul>	<ul style="list-style-type: none"> <li>Move the sensor to another location in the process line to ensure that it is full under all conditions.</li> </ul>
	<ul style="list-style-type: none"> <li>Moisture problem</li> </ul>	<ul style="list-style-type: none"> <li>Perform the sensor tests - see <a href="#">Sensor troubleshooting</a>.</li> </ul>
	<ul style="list-style-type: none"> <li>Insufficient upstream/downstream pipe diameter</li> </ul>	<ul style="list-style-type: none"> <li>Move sensor to a new location with 5 pipe diameters upstream and 2 pipe diameters downstream if possible.</li> </ul>
	<ul style="list-style-type: none"> <li>Cables for multiple magmeters run through same conduit</li> </ul>	<ul style="list-style-type: none"> <li>Use dedicated conduit run for each sensor and transmitter.</li> </ul>

**Table 12-7: Common magmeter issue (continued)**

Symptom	Electronics failure	Corrective action
	<ul style="list-style-type: none"> <li>Improper wiring</li> </ul>	<ul style="list-style-type: none"> <li>If electrode shield and electrode signal wires are switched, flow indication will be about half of what is expected. Check wiring diagrams.</li> </ul>
	<ul style="list-style-type: none"> <li>Flow rate is below 1 ft/s (specification issue)</li> </ul>	<ul style="list-style-type: none"> <li>See accuracy specification for specific transmitter and sensor.</li> </ul>
	<ul style="list-style-type: none"> <li>Auto zero was not performed when the coil drive frequency was changed from 5 Hz to 37 Hz</li> </ul>	<ul style="list-style-type: none"> <li>Set the coil drive frequency to 37 Hz, verify the sensor is full, verify there is no flow, and perform the auto zero function.</li> </ul>
	<ul style="list-style-type: none"> <li>Sensor failure—shorted electrode</li> </ul>	<ul style="list-style-type: none"> <li>Perform the sensor tests - see <a href="#">Sensor troubleshooting</a>.</li> </ul>
	<ul style="list-style-type: none"> <li>Sensor failure—shorted or open coil</li> </ul>	<ul style="list-style-type: none"> <li>Perform the sensor tests - see <a href="#">Sensor troubleshooting</a>.</li> </ul>
	<ul style="list-style-type: none"> <li>Transmitter failure</li> </ul>	<ul style="list-style-type: none"> <li>Verify transmitter operation with an 8714 Calibration Standard or replace the electronics board.</li> </ul>
Noisy Process	<ul style="list-style-type: none"> <li>Chemical additives upstream of magnetic flowmeter</li> </ul>	<ul style="list-style-type: none"> <li>See <a href="#">Troubleshooting high process noise</a>.</li> <li>Move injection point downstream of magnetic flowmeter, or move magnetic flowmeter.</li> </ul>
	<ul style="list-style-type: none"> <li>Sludge flows—mining/coal/sand/slurries (other slurries with hard particles)</li> </ul>	<ul style="list-style-type: none"> <li>Decrease flow rate below 10 ft/s.</li> </ul>
	<ul style="list-style-type: none"> <li>Styrofoam or other insulating particles in process</li> </ul>	<ul style="list-style-type: none"> <li>See <a href="#">Troubleshooting high process noise</a>.</li> <li>Consult factory.</li> </ul>
	<ul style="list-style-type: none"> <li>Electrode coating</li> </ul>	<ul style="list-style-type: none"> <li>Enable Coated Electrode Detection diagnostic.</li> <li>Use a smaller sensor to increase flow rate above 3 ft/s.</li> <li>Periodically clean sensor.</li> </ul>
	<ul style="list-style-type: none"> <li>Gas/air in line</li> </ul>	<ul style="list-style-type: none"> <li>Move the sensor to another location in the process line to ensure that it is full under all conditions.</li> </ul>
	<ul style="list-style-type: none"> <li>Low conductivity fluids (below 10 microsiemens/cm)</li> </ul>	<ul style="list-style-type: none"> <li>Trim electrode and coil wires – see <a href="#">Conduit requirements</a>.</li> <li>Keep flow rate below 3 ft/s.</li> <li>Integral mount transmitter.</li> <li>Use component cable - see <a href="#">Sensor to transmitter wiring</a>.</li> </ul>



**Table 12-7: Common magmeter issue (continued)**

Symptom	Electronics failure	Corrective action
Meter output is unstable	<ul style="list-style-type: none"> <li>Medium to low conductivity fluids (10–25 microsiemens/cm) combined with cable vibration or 60 Hz interference</li> </ul>	<ul style="list-style-type: none"> <li>Eliminate cable vibration.</li> <li>Move cable to lower vibration run.</li> <li>Tie down cable mechanically.</li> <li>Use an integral mount.</li> <li>Trim electrode and coil wires - see <a href="#">Sensor to transmitter wiring</a>.</li> <li>Route cable line away from other equipment powered by 60 Hz.</li> <li>Use component cable - see <a href="#">Sensor to transmitter wiring</a>.</li> </ul>
	<ul style="list-style-type: none"> <li>Electrode incompatibility</li> </ul>	<ul style="list-style-type: none"> <li>Check the <i>Technical Data Sheet, Magnetic Flowmeter Material Selection Guide</i> (document number 00816-0100-3033), for chemical compatibility with electrode material.</li> </ul>
	<ul style="list-style-type: none"> <li>Improper grounding</li> </ul>	<ul style="list-style-type: none"> <li>Check ground wiring – see <a href="#">Process reference connection</a> for wiring and grounding procedures.</li> </ul>
	<ul style="list-style-type: none"> <li>High local magnetic or electric fields</li> </ul>	<ul style="list-style-type: none"> <li>Move magnetic flowmeter (20–25 ft away is usually acceptable).</li> </ul>
	<ul style="list-style-type: none"> <li>Control loop improperly tuned</li> </ul>	<ul style="list-style-type: none"> <li>Check control loop tuning.</li> </ul>
	<ul style="list-style-type: none"> <li>Sticky valve (look for periodic oscillation of meter output)</li> </ul>	<ul style="list-style-type: none"> <li>Service valve.</li> </ul>
	<ul style="list-style-type: none"> <li>Sensor failure</li> </ul>	<ul style="list-style-type: none"> <li>Perform the sensor tests (See <a href="#">Sensor troubleshooting</a>).</li> </ul>

## 12.6 Sensor troubleshooting

This section describes manual tests that can be performed on the sensor to verify the health of individual components. The tests will require the use of a digital multimeter capable of measuring conductance in nanoSiemens and an LCR meter. A sensor circuit diagram is shown in [Figure 12-1](#). The tests described below will check for continuity or isolation of the internal components of the sensor.

Figure 12-1: Sensor Circuit Diagram (Simplified)

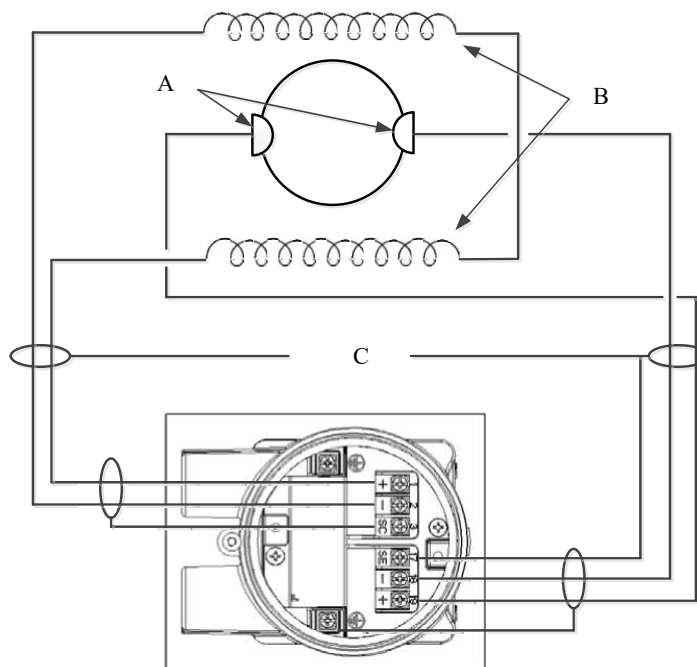

- A. Electrodes
- B. Coils
- C. Sensor housing

## 12.6.1 Sensor adapter feed through pins

The sensor adapter is the part of the sensor that provides the internal connection feed-through wiring from the internal sensor components to the socket module connections. The top of the adapter has 10 pins – four pins for the coils, four pins for the electrodes, and two pins for the process reference. Each connection point has two pins associated for redundant continuity. See [Figure 12-2](#).

The best location for testing the sensor components is taking measurements directly on the feed-through pins. Direct measurement on the pins eliminates the possibility of an erroneous measurement caused by a bad socket module or remote wiring. The figure below shows the feed-through pin connections as they relate to the terminal connections described in the tests.

**Figure 12-2: Sensor Adapter Feed-through Pins**

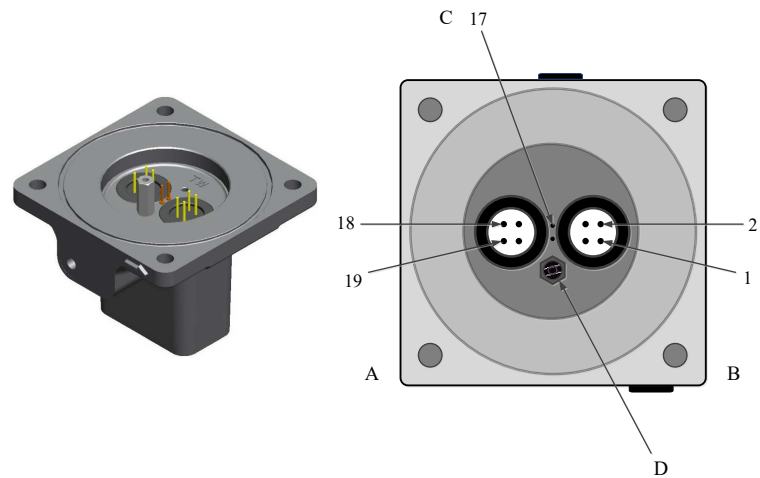

- A. Electrode side
- B. Coil side
- C. Process reference
- D. Orientation key

## 12.6.2 Socket module

The socket module connects the sensor adapter to the transmitter. There are two versions of the socket module—one for integral mount transmitters and one for remote mount transmitters. See [Figure 12-3](#) and [Figure 12-4](#). The socket module is a replaceable component. If test measurements taken through the socket module show a failure, remove the socket module and confirm measurements directly on the feed-through pins of the sensor adapter. To remove the socket module, refer to [Maintenance](#).

**Figure 12-3: Socket Module—Integral Mount**



Figure 12-4: Remote Mount Socket Module



## 12.7 Installed sensor tests

If a problem with an installed sensor is identified, refer to [Table 12-8](#) through [Table 12-12](#) to assist in troubleshooting the sensor. Disconnect or turn off power to the transmitter before performing any of the sensor tests. Always check the operation of test equipment before each test.

If possible, take all readings from the preferred locations identified in [Sensor adapter feed through pins](#), [Sensor adapter direct lead pins](#), and [Socket module](#). If the recommended locations in the sensor adapter are inaccessible, take measurements at the sensor terminal block or through remote cabling as close to the sensor as possible. Readings taken through remote cabling that is more than 100 feet (30 meters) in length may provide incorrect or inconclusive information and should be avoided.

The expected values in the test below assume the measurements have been taken directly at the pins.

Table 12-8: Test A. Sensor coil

Test conditions	Expected value	Potential cause	Corrective action
<ul style="list-style-type: none"> <li>Location: installed or uninstalled</li> <li>Required equipment: multimeter</li> <li>Measuring at connections: 1 and 2 = R</li> </ul>	$2\Omega \leq R \leq 18\Omega$	<ul style="list-style-type: none"> <li>Open or shorted coil</li> </ul>	<ul style="list-style-type: none"> <li>Remove and replace sensor.</li> </ul>

**Table 12-9: Test B: Shields to case**

Test conditions	Expected value	Potential cause	Corrective action
<ul style="list-style-type: none"> <li>Location: installed or uninstalled</li> <li>Required equipment: multimeter</li> <li>Measuring at connections:                             <ul style="list-style-type: none"> <li>— 17 and 3</li> <li>— 3 and case ground</li> <li>— 17 and case ground</li> </ul> </li> </ul>	< 0.3Ω	<ul style="list-style-type: none"> <li>Moisture in terminal block</li> <li>Leaky electrode</li> <li>Process behind liner</li> </ul>	<ul style="list-style-type: none"> <li>Clean terminal block.</li> <li>Remove sensor.</li> </ul>

**Table 12-10: Test C. Coil to coil shield**

Test conditions	Expected value	Potential cause	Corrective action
<ul style="list-style-type: none"> <li>Location: installed or uninstalled</li> <li>Required equipment: multimeter</li> <li>Measuring at connections:                             <ul style="list-style-type: none"> <li>— 1 and 3</li> <li>— 2 and 3</li> </ul> </li> </ul>	∞Ω (< 1nS)	<ul style="list-style-type: none"> <li>Process behind liner</li> <li>Leaky electrode</li> <li>Moisture in terminal block</li> </ul>	<ul style="list-style-type: none"> <li>Remove sensor and dry.</li> <li>Clean terminal block.</li> <li>Confirm with sensor coil test.</li> </ul>

**Table 12-11: Test D. Electrode to electrode shield**

Test conditions	Expected value	Potential cause	Corrective action
<ul style="list-style-type: none"> <li>Location: installed</li> <li>Required equipment: LCR (Set to Resistance and 120 Hz)</li> <li>Measuring at connections:                             <ul style="list-style-type: none"> <li>— 18 and 17 = R<sub>1</sub></li> <li>— 19 and 17 = R<sub>2</sub></li> </ul> </li> </ul>	<ul style="list-style-type: none"> <li>R<sub>1</sub> and R<sub>2</sub> should be stable</li> <li> R<sub>1</sub>-R<sub>2</sub>  ≤ 300Ω</li> </ul>	<ul style="list-style-type: none"> <li>Unstable R<sub>1</sub> or R<sub>2</sub> values confirm coated electrode</li> <li>Shorted electrode</li> <li>Electrode not in contact with process</li> <li>Empty pipe</li> <li>Low conductivity</li> <li>Leaky electrode</li> <li>Process reference ground not connected properly</li> </ul>	<ul style="list-style-type: none"> <li>Remove coating from sensor wall.</li> <li>Use bullet-nose electrodes.</li> <li>Repeat measurement.</li> <li>Remove sensor and complete tests in <a href="#">Uninstalled sensor tests</a>.</li> <li>Connect process reference ground per <a href="#">Process reference connection</a>.</li> </ul>

**Table 12-12: Test E. Electrode to Electrode**

Test conditions	Expected value	Potential cause	Corrective action
<ul style="list-style-type: none"> <li>Location: installed</li> <li>Required equipment: LCR (Set to Resistance and 120 Hz)</li> <li>Measuring at connections: 18 and 19                             <ul style="list-style-type: none"> <li>— 18 and 17 = R<sub>1</sub></li> <li>— 19 and 17 = R<sub>2</sub></li> </ul> </li> </ul>	Should be stable and same relative magnitude of R <sub>1</sub> and R <sub>2</sub> from Test D	<ul style="list-style-type: none"> <li>Unstable R<sub>1</sub> or R<sub>2</sub> values confirm coated electrode</li> <li>Shorted electrode</li> <li>Electrode not in contact with process</li> <li>Empty pipe</li> <li>Low conductivity</li> <li>Leaky electrode</li> <li>Process reference ground not connected properly</li> </ul>	<ul style="list-style-type: none"> <li>Remove coating from sensor wall.</li> <li>Use bullet-nose electrodes.</li> <li>Repeat measurement.</li> <li>Remove sensor and complete tests in <a href="#">Uninstalled sensor tests</a>.</li> <li>Connect process reference ground per <a href="#">Process reference connection</a>.</li> </ul>

To test the sensor, a multimeter capable of measuring conductance in nanoSiemens is preferred. Conductance is the reciprocal of resistance.

Or:

$$1 \text{ nanosiemens} = \frac{1}{1 \text{ gigaohm}}$$

$$1 \text{ nanosiemens} = \frac{1}{1 \times 10^9 \text{ ohm}}$$

## 12.8 Uninstalled sensor tests

Sensor troubleshooting can also be performed on an uninstalled sensor. If test results from installed sensor tests are inconclusive, the next step is remove the sensor and perform the tests outlined in this section. Take measurements from the recommended terminal location, and directly on the electrode head inside the sensor. The measurement electrodes, 18 and 19, are on opposite sides in the inside diameter of the sensor. If applicable, the third process reference electrode is between the two measurement electrodes.

The expected values in the test below assume the measurements have been taken directly at the pins.

**Table 12-13: Test A. Terminal to front electrode**

Test conditions	Expected value	Potential cause	Corrective action
<ul style="list-style-type: none"> <li>Location: uninstalled</li> <li>Required equipment: Multimeter</li> <li>18 and electrode 18<sup>(1)</sup></li> </ul>	≤ 1 Ω	<ul style="list-style-type: none"> <li>Shorted electrode</li> <li>Open electrode</li> <li>Coated electrode</li> </ul>	<ul style="list-style-type: none"> <li>Replace sensor</li> <li>Remove coating from sensor wall</li> </ul>

(1) When the connection head is in the vertical upright position and the flow arrow (see [Flow direction](#)) on the connection head flange points to the right, the front of the meter will be facing towards you. Electrode 18 is on the front of the meter. If you cannot determine the front of the meter, measure both electrodes. One electrode should result in an open reading, while the other electrode should be less than 0.3 ohm.

**Table 12-14: Test B. Terminal to back electrode**

Test conditions	Expected value	Potential cause	Corrective action
<ul style="list-style-type: none"> <li>Location: uninstalled</li> <li>Required equipment: Multimeter</li> <li>19 and electrode 19<sup>(1)</sup></li> </ul>	$\leq 1 \Omega$	<ul style="list-style-type: none"> <li>Shorted electrode</li> <li>Open electrode</li> <li>Coated electrode</li> </ul>	<ul style="list-style-type: none"> <li>Replace sensor</li> <li>Remove coating from sensor wall</li> </ul>

(1) When the connection head is in the vertical upright position and the flow arrow (see *Flow direction*) on the connection head flange points to the right, the front of the meter will be facing towards you. Electrode 18 is on the front of the meter. If you cannot determine the front of the meter, measure both electrodes. One electrode should result in an open reading, while the other electrode should be less than 0.3 ohm.

**Table 12-15: Test C. Terminal to reference electrode**

Test conditions	Expected value	Potential cause	Corrective action
<ul style="list-style-type: none"> <li>Location: uninstalled</li> <li>Required equipment: Multimeter</li> <li>17 and process reference electrode<sup>(1)</sup></li> </ul>	$\leq 0.3 \Omega$	<ul style="list-style-type: none"> <li>Shorted electrode</li> <li>Open electrode</li> <li>Coated electrode</li> </ul>	<ul style="list-style-type: none"> <li>Replace sensor</li> <li>Remove coating from sensor wall</li> </ul>

(1) Only valid if the sensor has a process reference electrode.

**Table 12-16: Test D. Terminal to case ground**

Test conditions	Expected value	Potential cause	Corrective action
<ul style="list-style-type: none"> <li>Location: uninstalled</li> <li>Required equipment: Multimeter</li> <li>17 and safety ground</li> </ul>	$\leq 0.3 \Omega$	<ul style="list-style-type: none"> <li>Moisture in terminal block</li> <li>Leaky electrode</li> <li>Process behind liner</li> </ul>	<ul style="list-style-type: none"> <li>Clean terminal block</li> <li>Replace terminal block</li> <li>Replace sensor</li> </ul>

**Table 12-17: Test E. Electrode to electrode shield**

Test conditions	Expected value	Potential cause	Corrective action
<ul style="list-style-type: none"> <li>Location: uninstalled</li> <li>Required equipment: Multimeter</li> <li>18 and 17</li> <li>19 and 17</li> </ul>	$\infty \Omega (< 1 \text{ nS})$	<ul style="list-style-type: none"> <li>Shorted electrode</li> <li>Leaky electrode</li> <li>Moisture in terminal block</li> </ul>	<ul style="list-style-type: none"> <li>Replace sensor</li> <li>Clean terminal block</li> <li>Replace terminal block</li> </ul>

**Table 12-18: Test F. Electrode shield to coil**

Test conditions	Expected value	Potential cause	Corrective action
<ul style="list-style-type: none"> <li>Location: uninstalled</li> <li>Required equipment: Multimeter</li> <li>17 and 1</li> </ul>	$\infty \Omega (< 1 \text{ nS})$	<ul style="list-style-type: none"> <li>Process in coil housing</li> <li>Moisture in terminal block</li> </ul>	<ul style="list-style-type: none"> <li>Replace sensor</li> <li>Clean terminal block</li> <li>Replace terminal block</li> </ul>

## 12.9 Technical support and service

Email addresses:

Worldwide: [flow.support@emerson.com](mailto:flow.support@emerson.com)

Asia-Pacific: [APflow.support@emerson.com](mailto:APflow.support@emerson.com)

Middle East and Africa: [FlowTechnicalSupport@emerson.com](mailto:FlowTechnicalSupport@emerson.com)

## 12.10 Service

To expedite the return process outside the United States, contact an Emerson representative.



# A Product specifications

## A.1 Rosemount 8700M Flowmeter Platform specifications

The tables below outline some of the basic performance, physical, and functional specifications of the Rosemount 8700M Magnetic Flowmeter Platform.

**Table A-1: Rosemount 8732EM Transmitter Specifications**



8732EM Transmitter		
	Model	8732EM
	Base accuracy <sup>(1)</sup>	0.25% Standard 0.15% High Accuracy Option
	Mounting	Integral or Remote
	Power supply	Global AC or DC
	User interface	LCD display with 4 Optical Switch LOI LCD display only No display
	Communication protocol	Modbus RS-485
	Diagnostics	Basic, DA1, DA2
	Sensor compatibility	All Rosemount plus other manufacturers
	Detailed specifications	<a href="#">Transmitter specifications</a>
	Ordering information	Product Data Sheet

(1) For complete accuracy specifications, please refer to [Transmitter functional specifications](#).

**Table A-2: Rosemount Sensor Specifications**



8705 Sensor		
	Style	Flanged
	Base accuracy <sup>(1)</sup>	0.25% Standard 0.15% High Accuracy Option
	Line sizes	½-in. to 36-in. (15 mm to 900 mm)
	Design features	Standard Process Design
	Detailed specifications	<a href="#">8705-M Flanged Sensor Specifications</a>
	Ordering information	Product Data Sheet

**Table A-2: Rosemount Sensor Specifications (continued)**



8711 Sensor		
	Style	Wafer
	Base accuracy <sup>(1)</sup>	0.25% Standard 0.15% High Accuracy Option
	Line sizes	1½ -in. to 8-in. (40 mm to 200 mm)
	Design features	Compact, Light Weight
	Detailed specifications	<a href="#">8711-M/L Wafer Sensor Specifications</a>
	Ordering information	Product Data Sheet
8721 Sensor		
	Style	Hygienic (sanitary)
	Base accuracy <sup>(1)</sup>	0.5% Standard 0.25% High Accuracy Option
	Line sizes	½-in. to 4-in. (15 mm to 100 mm)
	Design features	3-A CIP/SIP
	Detailed specifications	<a href="#">8721 Hygienic (Sanitary) Sensor Specifications</a>
	Ordering information	Product Data Sheet

(1) For complete accuracy specifications, refer to the sensor's detailed specifications.

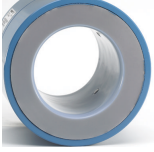
**Table A-3: Lining Material Selection**

Liner material	General characteristics
PFA, PFA+ 	Best chemical resistance
	Better abrasion resistance than PTFE
	Best high temperature capabilities
	Process temperature: -58 to 350 °F (-50 to 177 °C)
PTFE 	Highly chemical resistant
	Excellent high temperature capabilities
	Process temperature: -58 to 350 °F (-50 to 177 °C)
ETFE 	Excellent chemical resistance
	Better abrasion resistance than PTFE
	Process temperature: -58 to 300 °F (-50 to 149 °C)

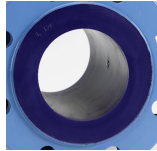
**Table A-3: Lining Material Selection (continued)**

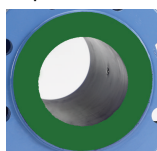
Liner material	General characteristics
Polyurethane 	Limited chemical resistance
	Excellent abrasion resistance for slurries with small and medium particles
	Process temperature: 0 to 140 °F (-18 to 60 °C)
	Typically applied in clean water
Neoprene 	Very good abrasion resistance for small and medium particles
	Better chemical resistance than polyurethane
	Typically applied in water with chemicals, and sea water
	Preferred liner for high pressure > ASME B16.5 Class 900
Linatex Rubber 	Limited chemical resistance especially in acids
	Very good abrasion resistance for large particles
	Softer material than polyurethane and neoprene
	Typically applied in mining slurries
Adiprene 	Ideal for applications with high salinity and/or hydrocarbon carryover
	Excellent abrasion resistance
	Typically used for Water Injection, Recovered Water, and Coal Gasification Slurries
	Preferred liner for high pressure > ASME B16.5 Class 900
	Process temperature: 0 to 200 °F (-18 to 93 °C)

**Table A-4: Electrode Material**

Electrode material	General characteristics
316L Stainless Steel	Good corrosion resistance
	Good abrasion resistance
	Not recommended for sulfuric or hydrochloric acids
Nickel Alloy 276 (UNS N10276)	Better corrosion resistance
	High strength
	Good in slurry applications
	Effective in oxidizing fluids
Tantalum	Excellent corrosion resistance
	Not recommended for hydrofluoric acid, fluorosilic acid, or sodium hydroxide
80% Platinum 20% Iridium	Best chemical resistance
	Expensive material
	Not recommended for aquaregia

**Table A-4: Electrode Material (continued)**

Electrode material	General characteristics
Titanium	Better chemical resistance
	Better abrasion resistance
	Good for sea water applications
	Not recommended for hydrofluoric or sulfuric acid
Tungsten Carbide coated	Limited chemical resistance
	Best abrasion resistance
	High concentration slurries
	Preferred electrode for oil and gas fracturing applications

**Table A-5: Electrode Type**

Electrode type	General characteristics
Standard Measurement	Lowest cost
	Good for most applications
Measurement + Reference Electrode (Also see <a href="#">Table A-6</a> and <a href="#">Table A-7</a> for grounding options and installation)	Low cost grounding option especially for large line sizes
	If using a reference electrode, process fluid must have a minimum conductivity of 100 microSiemens/cm
	Not recommended for electrolytic or galvanic corrosion applications
Bulldog	Extended head protrudes into the flow stream for self-cleaning
	Best option for coating processes
Flat Head	Low profile head
	Best option for abrasive slurries

**Table A-6: Process Reference Options**

Grounding options	General characteristics
No Grounding Options (grounding straps)	Acceptable for conductive unlined pipe
	Grounding straps provided at no cost
Reference Electrode	Same material as measurement electrodes
	Sufficient grounding option when process fluid conductivity is greater than 100 microSiemens/cm
	Not recommended in electrolysis applications, galvanic corrosion applications, applications where the electrodes may coat, or non-conductive pipe.

**Table A-6: Process Reference Options (continued)**

Grounding options	General characteristics
Grounding Rings	Low conductivity process fluids
	Cathodic or electrolysis applications that may have stray currents in or around the process
	Variety of materials for process fluid compatibility
Lining Protectors	Protect upstream edge of sensor from abrasive fluids
	Permanently installed on sensor
	Protect liner material from over torquing of flange bolts
	Provide ground path and eliminate need for grounding rings or reference electrode
	Required for applications where Flexitallic gaskets are used

**Table A-7: Process Reference Installation**

Type of pipe	Grounding straps	Grounding rings	Reference electrode	Lining protectors
Conductive unlined pipe	Acceptable	Not required	Not required	Not required
Conductive lined pipe	Not acceptable	Acceptable	Acceptable	Acceptable
Non-conductive pipe	Not acceptable	Acceptable	Not recommended	Acceptable

## A.2 Transmitter specifications

### A.2.1 Transmitter functional specifications

#### Sensor compatibility

Compatible with Rosemount 8705, 8711, and 8721 sensors. Compatible with AC and DC powered sensors of other manufacturers.

#### Transmitter coil drive current

500 mA

#### Flow rate range

Capable of processing signals from fluids with velocities between 0.04 and 39 ft/s (0.01 to 12 m/s) for both forward and reverse flow in all sensor sizes. Full scale continuously adjustable between -39 and 39 ft/s (-12 to 12 m/s).

#### Conductivity limits

Process liquid must have a conductivity of 5 microSiemens/cm (5 micromhos/cm) or greater.

#### Power supply

- 90 - 250 VAC @ 50/60 Hz

- 12 - 42 VDC
- 12 - 30 VDC

#### Line power fuses

- 90 - 250 VAC systems:
  - 2 amp quick acting
  - Bussman AGC2 or equivalent
- 12 - 42 VDC systems
  - 3 amp quick acting
  - Bussman AGC3 or equivalent
- 12 - 30 VDC systems
  - 3 amp quick acting
  - Bussman AGC3 or equivalent

#### Power consumption

- 90 - 250 VAC: 40 VA maximum
- 12 - 42 VDC: 15 W maximum
- 12 - 30 VDC: 4 W maximum

#### Switch-on current

- At 250 VAC: Maximum 35.7 A (< 5 ms)
- At 42 VDC: Maximum 42 A (< 5 ms)
- At 30 VDC: Maximum 42 A (< 5 ms)

#### AC power supply requirements

Units powered by 90 - 250 VAC have the following power requirements. Peak inrush is 35.7 A at 250 VAC supply, lasting approximately 1 ms. Inrush for other supply voltages can be estimated with:  $\text{Inrush (Amps)} = \text{Supply (Volts)} / 7.0$

Figure A-1: AC current requirements

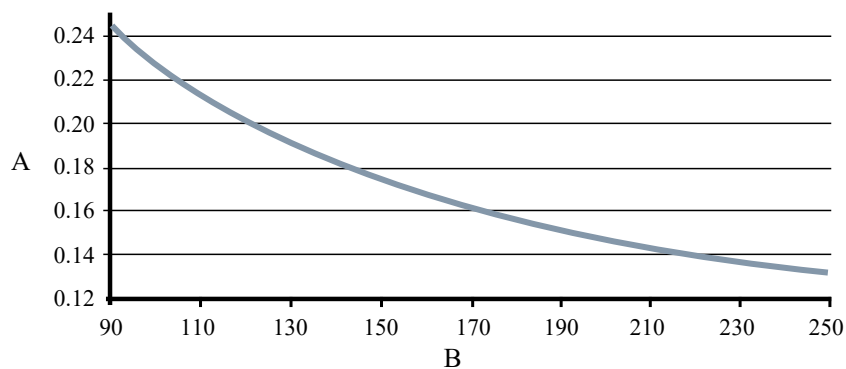

A. Supply current (amps)

B. Power supply (VAC)

**Figure A-2: Apparent power**

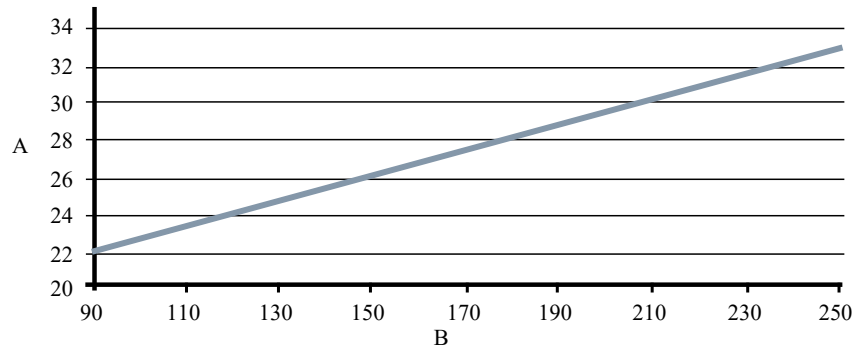

- A. Apparent power (VA)
- B. Power supply (VAC)

**DC power supply requirements**

Standard DC Units powered by 12 VDC power supply may draw up to 1.2 A of current steady state. Low power DC units may draw up to 0.25 A of current steady state. Peak inrush is 42 A at 42 VDC supply, lasting approximately 1 ms. Inrush for other supply voltages can be estimated with:  $\text{Inrush (Amps)} = \text{Supply (Volts)} / 1.0$

**Figure A-3: DC current requirements**

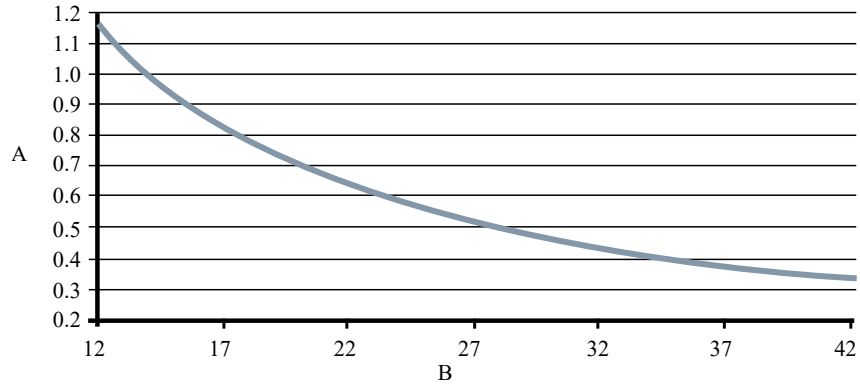

- A. Supply current (amps)
- B. Power supply (VDC)

### DC low power supply requirements

**Figure A-4: Low power DC current requirements**

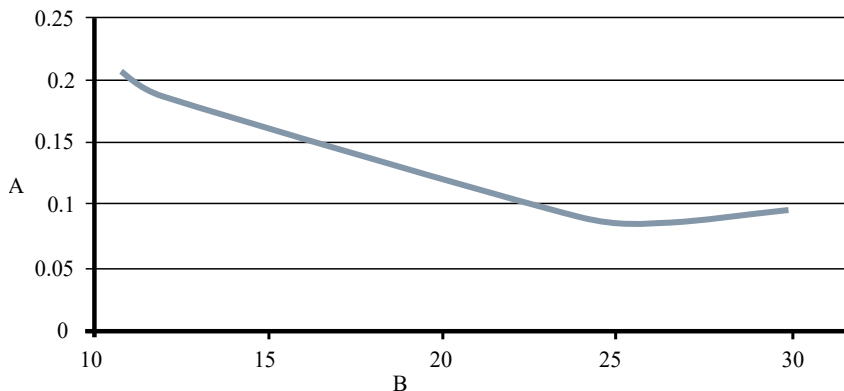

A. Supply current (amps)

B. Power supply (VDC)

### Low power software option

This software option lowers the coil current from 500 mA to 75 mA in order to conserve power for applications in remote locations where power is scarce. The coils are still driven in a continuous manner optimizing measurement performance and providing access to all diagnostic capabilities. Because of the reduced coil current, flow measurement accuracy is reduced to 1% of rate for low power systems. Table A-8 shows the power consumption that can be expected for various configurations. Due to the reduced coil current, sensor size is limited to a maximum line size of 10-in. (250 mm).

The low power option is available for integral mount with DC power only (option code 3) and output code M (Modbus RS-485 / Pulse). To ensure the sensor will support the low power functionality, option code D3 for a low power calibration must appear in the sensor model number.

Sample model numbers for a low power system are:

8732EMT3M1N6M4DA1DA2

8705DHA020D7M0N6B3D3

**Table A-8: Low power consumption**

Output code	Power consumption	Flow accuracy	Measurement range
Output Code B Utilize Pulse Output Only	2 Watts Maximum	1% of Rate	0.04 fps to 39 fps 0.01 m/s to 12 m/s
Output Code B Utilize Pulse and Analog Output	3 Watts Maximum	1% of Rate	0.04 fps to 39 fps 0.01 m/s to 12 m/s
Output code M Utilizing Modbus RS-485 and Pulse Output	4 Watts Maximum	1% of Rate	0.04 fps to 39 fps 0.01 m/s to 12 m/s



### Ambient temperature limits

- Operating:
  - -58 to 140 °F (-50 to 60 °C) without LOI/Display
  - -4 to 140 °F (-20 to 60 °C) with LOI/Display
  - The LOI/Display will not be visible at temperatures below -4 °F (-20 °C).
- Storage:
  - -58 to 185 °F (-50 to 85 °C) without LOI/Display
  - -22 to 176 °F (-30 to 80 °C) with LOI/Display

### Humidity limits

0-95% RH to 140 °F (60 °C)

### Altitude limits

AC Input Voltage: Maximum 250 VAC – Up to 2000 meters ( 6,500 feet)

AC Input Voltage: Maximum 150 VAC – Up to 4000 meters (13,000 feet)

DC Input Voltage: No altitude limit

### Transient protection rating

Built in transient protection that conforms to:

- IEC 61000-4-4 for burst currents
- IEC 61000-4-5 for surge currents
- IEC 611185-2.2000, Class 3 up to 2 kV and up to 2 kA protection

### Turn-on time

- 5 minutes to rated accuracy from power up
- 5 seconds from power interruption

### Start-up time

50 ms from zero flow

### Low flow cut-off

Adjustable between 0.01 and 38.37 ft/s (0.003 and 11.7 m/s). Below selected value, output is driven to the zero flow rate signal level.

### Overrange capability

Signal output will remain linear until 110% of upper range value or 44 ft/s (13 m/s). The signal output will remain constant above these values. Out of range message displayed on LOI/Display and the Field Communicator.

### Damping

Adjustable between 0 and 256 seconds

## A.2.2 Advanced diagnostics capabilities

### Basic

- Self test
- Transmitter faults

- Pulse output test
- Tunable empty pipe
- Reverse flow
- Ground/wiring fault
- Coil circuit fault
- Electronics temperature

#### Process diagnostics (DA1)

- High process noise
- Electrode coating diagnostic

#### Smart Meter Verification (DA2)

- Smart Meter Verification (continuous or commanded)

## A.2.3 Output signals

### Analog alarm mode

High or low alarm signal is user-selectable via the Alarm switch on the front of the electronics. NAMUR-compliant alarm limits are software configurable and can be preset via CDS (C1). Individual diagnostic alarms are also software configurable. Alarms will drive the analog signal to the following mA values.

Low	3.75 mA	Requires CDS (C1)
High	22.50 mA	Factory default
NAMUR Low	3.5 mA	Requires CDS (C1)
NAMUR High	22.6 mA	Requires CDS (C1)

### Modbus RS-485 output

Transmitters with a Modbus output provide an RS-485 signal to a Modbus host system; data rates can be configured from 1200 baud to 115.2 kilobaud.

### Scalable pulse frequency adjustment

- 0-10,000 Hz, switch-selectable as internally or externally powered <sup>(1)</sup>
- Pulse value can be set to equal desired volume in selected engineering units
- Pulse width adjustable from 0.1 to 650 ms
- Internally powered: Outputs up to 12 VDC<sup>(2)</sup>
- Externally powered: Input 5 - 28 VDC

### Output testing

**Pulse output test** Transmitter may be commanded to supply a specified frequency between 1 and 10,000 Hz.<sup>(1)</sup>

<sup>(1)</sup> For transmitters with intrinsically safe outputs (option code B), frequency range is limited to 0-5000 Hz and must be powered externally.

<sup>(2)</sup> For transmitters with intrinsically safe outputs (option code B), power must be supplied externally.

### Optional discrete output function (AX option)

Externally powered at 5 - 28 VDC, 240 mA max, solid state switch closure to indicate either:

<b>Reverse flow</b>	Activates switch closure output when reverse flow is detected.
<b>Zero flow</b>	Activates switch closure output when flow goes to 0 ft/s or below low flow cutoff.
<b>Empty pipe</b>	Activates switch closure output when an empty pipe condition is detected.
<b>Transmitter faults</b>	Activates switch closure output when a transmitter fault is detected.
<b>Flow limit 1, flow limit 2</b>	Activates switch closure output when the transmitter measures a flow rate that meets the conditions established for this alert. There are two independent flow limit alerts that can be configured as discrete outputs.
<b>Totalizer limit</b>	Activates switch closure output when the transmitter measures a total flow that meets the conditions established for this alert.
<b>Diagnostic status</b>	Activates switch closure output when the transmitter detects a condition that meets the configured criteria of this output.

### Optional discrete input function (AX option)

Externally powered at 5 - 28 VDC, 1.4 - 20 mA to activate switch closure to indicate either:

<b>Reset Totalizer A (or B or C)</b>	Resets Totalizer A (or B or C) value to zero.
<b>Reset All Totals</b>	Resets all totalizer values to zero.
<b>Positive Zero Return (PZR)</b>	Forces outputs of the transmitter to zero flow.

### Sensor compensation

Rosemount sensors are calibrated in a flow lab at the factory and are assigned a calibration number. The calibration number must be entered into the transmitter, enabling interchangeability of sensors without calculations or a compromise in standard accuracy.

Transmitters and other manufacturers' sensors can be calibrated at known process conditions or at the Rosemount NIST-Traceable Flow Facility. Transmitters calibrated on site require a two-step procedure to match a known flow rate. This procedure can be found in the operations manual.

## A.2.4 Performance specifications

**System specifications are given using the frequency output and with the unit at reference conditions.**

### Accuracy

Includes the combined effects of linearity, hysteresis, and repeatability.

### Rosemount 8705-M Sensor

- Standard system accuracy:
  - ±0.25% of rate ±1.0 mm/sec from 0.04 to 6 ft/s (0.01 to 2 m/s)
  - ±0.25% of rate ±1.5 mm/sec above 6 ft/s (2 m/s)
- Optional high accuracy:<sup>(3)</sup>
  - ±0.15% of rate ±1.0 mm/sec from 0.04 to 13 ft/s (0.01 to 4 m/s)
  - ±0.18% of rate above 13 ft/s (4 m/s)

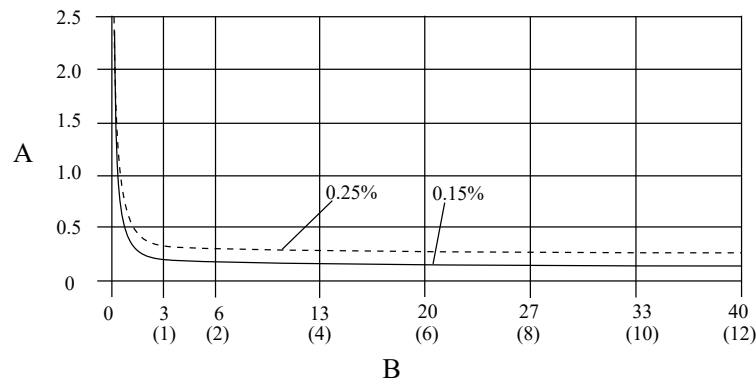

A. Percentage of rate  
B. Velocity in ft/s (m/s)

### Rosemount 8711-M/L Sensor

- Standard system accuracy:
  - ±0.25% of rate ±2.0 mm/sec from 0.04 to 39 ft/s (0.01 to 12 m/s)
- Optional high accuracy:
  - ±0.15% of rate ±1.0 mm/sec from 0.04 to 13 ft/s (0.01 to 4 m/s)
  - ±0.18% of rate above 13 ft/s (4 m/s)

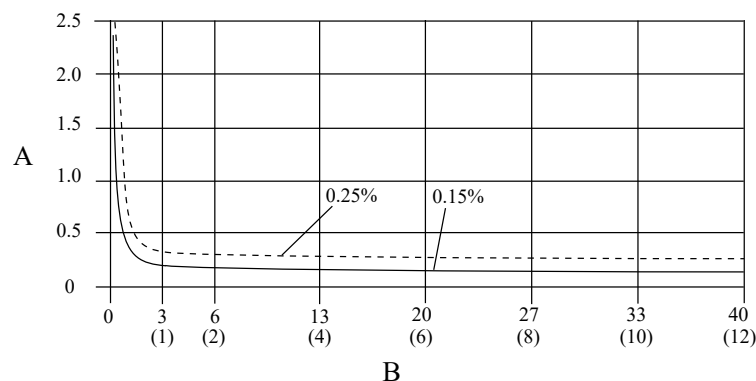

A. Percentage of rate  
B. Velocity in ft/s (m/s)

<sup>(3)</sup> For sensor sizes greater than 12 in. (300 mm), the high accuracy is ±0.25% of rate from 3 to 39 ft/sec (1 to 12 m/sec).

### Rosemount 8721 Sensor

- Standard system accuracy:
  - ±0.5% of rate ±1.5 mm/s from 0.04 to 1.0 ft/s (0.01 and 0.3 m/s)
  - ±0.5% of rate from 1 to 39 ft/s (0.3 to 12 m/s)
- Optional high accuracy:
  - ±0.25% of rate from 3 to 39 ft/s (1 to 12 m/s):

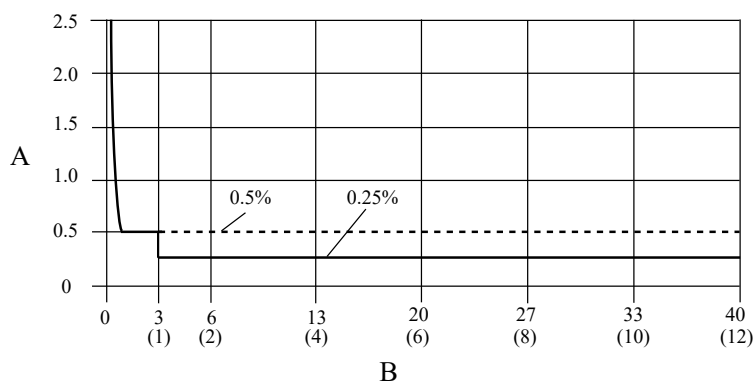

A. Percentage of rate  
B. Velocity in ft/s (m/s)

### Other manufacturers' sensors

- When calibrated in the Rosemount Flow Facility, system accuracies as good as 0.5% of rate can be attained.
- There is no accuracy specification for other manufacturers' sensors calibrated in the process line.

### Analog output effects

Analog output has the same accuracy as frequency output plus an additional  $\pm 4 \mu A$  at room temperature.

Repeatability	$\pm 0.1\%$ of reading
Response time (analog output)	20 ms max response time to step change in input
Stability	$\pm 0.1\%$ of rate over six months
Ambient temperature effect	$\pm 0.25\%$ change over operating temperature range

## A.2.5 8732 Field mount transmitter physical specifications

### Materials of construction

Standard housing	Low copper aluminum Type 4X and IEC 60529 IP66/67/68/69 <sup>(1)</sup>
Paint	Polyurethane coat (1.8 to 2.2 mils thick)

Cover gasket	Aluminum housing: Buna-N 316 SST housing: Silicone
--------------	---

(1) For applications where the transmitter may be submerged, even temporarily, contact Emerson Flow Technical Support for details.

#### Electrical connections

Conduit entries	Available in ½ inch NPT or M20. See ordering table footnotes for details.
Terminal block screws	6-32 (No. 6) suitable for up to 14 AWG wire
Safety grounding screws	External stainless assembly, M5; internal 8-32 (No. 8)

#### Vibration rating

Integral mount	2G per IEC 61298
Remote mount	5G per IEC 61298

#### Dimensions

See Product Data Sheet.

#### Weight

Field mount transmitter only	Aluminum	Approximately 7 lbs. (3.2 kg)
------------------------------	----------	-------------------------------

Add 1 pound (0.5 kg) for LOI/Display.

## A.3 8705-M Flanged Sensor Specifications



### A.3.1 Functional specifications

#### Service

Conductive liquids and slurries

#### Line sizes

½ inch to 36 inch (15 mm to 900 mm)

#### Sensor coil resistance

2 - 20 Ω

### Interchangeability

Rosemount 8705-M sensors are interchangeable with 8712EM and 8732EM transmitters. System accuracy is maintained regardless of line size or optional features. Each sensor nameplate has a sixteen-digit calibration number that can be entered into a transmitter during configuration.

### Upper range limit

39.37 ft/s (12 m/s)

### Ambient temperature limits

- -20 to 140 °F (-29 to 60 °C) standard carbon steel housing design
- -58 to 140 °F (-50 to 60 °C) with "SH" all stainless housing design<sup>(4)</sup>

### Pressure limits

See [Process temperature limits](#).

### Vacuum limits

PTFE lining	Full vacuum to +350 °F (+177 °C) through 4-in. (100 mm) line sizes. Consult an Emerson Flow representative for vacuum applications with line sizes of 6 inches (150 mm) or larger.
All other standard sensor lining materials	Full vacuum to maximum material temperature limits for all available line sizes.

### Submergence protection IP68

The remote mount sensor is rated IP68 for continuous submergence. Tested to a depth of 33 ft. (10 m) for a period of 48 hours. IP68 rating requires that the transmitter must be remote mount. Installer must use IP68 approved cable glands, conduit connections, and/or conduit plugs.

### Conductivity limits

Process liquid must have a conductivity of 5 microSiemens/cm or greater. Consult an Emerson Flow representative for conductivity less than 5 microSiemens/cm.

### Process temperature limits

PTFE lining	-58 to +350 °F (-50 to +177 °C)
ETFE lining	-58 to +300 °F (-50 to +149 °C)
PFA and PFA+ lining	-58 to +350 °F (-50 to +177 °C)
Polyurethane lining	0 to +140 °F (-18 to +60 °C)
Neoprene lining	0 to +176 °F (-18 to +80 °C)
Linatex lining	0 to +158 °F (-18 to +70 °C)
Adiprene lining	0 to +200 °F (-18 to +93 °C)

### Notes

- Carbon steel flanges for PED have a minimum process temperature limit of 32 °F (0 °C).

<sup>(4)</sup> Not available for Class/Div approval codes N5, N6, K5, KU.

- Sensors ordered with hazardous location ratings may have different maximum process temperature limits. The sensors must be installed and used as directed by the installation drawing number noted on the serial nameplate.

**Table A-9: Temperature vs. Pressure Limits for ASME B16.5 class flanges <sup>(1)</sup>**

Sensor temperature vs. pressure limits for ASME B16.5 class flanges (up to 36 inch line sizes) <sup>(2)</sup>					
Flange material	Flange rating	Pressure			
		@ -20 to 100 °F (-29 to 38 °C)	@ 200 °F (93 °C)	@ 300 °F (149 °C)	@ 350 °F (177 °C)
Carbon Steel	Class 150	285 psi	260 psi	230 psi	215 psi
	Class 300	740 psi	680 psi	655 psi	645 psi
	Class 600 <sup>(3)</sup>	1000 psi	800 psi	700 psi	650 psi
	Class 600 <sup>(4)</sup>	1480 psi	1350 psi	1315 psi	1292 psi
	Class 900	2220 psi	2025 psi	1970 psi	1935 psi
	Class 1500	3705 psi	3375 psi	3280 psi	3225 psi
	Class 2500	6170 psi	5625 psi	5470 psi	5375 psi
304/304L Stainless Steel	Class 150	275 psi	235 psi	205 psi	190 psi
316/316L Stainless Steel	Class 300	720 psi	620 psi	530 psi	500 psi
	Class 600 <sup>(3)</sup>	1000 psi	800 psi	700 psi	650 psi
	Class 600 <sup>(4)</sup>	1440 psi	1200 psi	1055 psi	997 psi
	Class 900	2160 psi	1800 psi	1585 psi	1497 psi
	Class 1500	3600 psi	3000 psi	2640 psi	2495 psi
	Class 2500	6000 psi	5000 psi	4400 psi	4160 psi

(1) Liner temperature limits must also be considered.

(2) 30-in. and 36-in. AWWA C207 Class D rated to 150 psi at atmospheric temperature.

(3) Flange rating Code 6.

(4) Flange rating Code 7.

**Table A-10: Temperature vs. Pressure Limits for AS2129 Table D and E flanges <sup>(1)</sup>**

Sensor temperature vs. pressure limits for AS2129 Table D and E flanges (4 inch to 24 inch line sizes)					
Flange Material	Flange Rating	Pressure			
		@ -29 to 50 °C (-20 to 122 °F)	@ 100 °C (212 °F)	@ 150 °C (302 °F)	@ 200 °C (392 °F)
Carbon Steel	D	101.6 psi	101.6 psi	101.6 psi	94.3 psi
	E	203.1 psi	203.1 psi	203.1 psi	188.6 psi

(1) Liner temperature limits must also be considered.



**Table A-11: Temperature vs. Pressure Limits for EN 1092-1 flanges <sup>(1)</sup>**

Sensor temperature vs. pressure limits for EN 1092-1 flanges (15 mm to 600 mm Line Sizes)					
Flange material	Flange rating	Pressure			
		@ -29 to 50 °C (-20 to 122 °F)	@ 100 °C (212 °F)	@ 150 °C (302 °F)	@ 175 °C (347 °F)
Carbon Steel	PN 10	10 bar	10 bar	9.7 bar	9.5 bar
	PN 16	16 bar	16 bar	15.6 bar	15.3 bar
	PN 25	25 bar	25 bar	24.4 bar	24.0 bar
	PN 40	40 bar	40 bar	39.1 bar	38.5 bar
304/304L Stainless Steel 316/316L Stainless Steel	PN 10	9.1 bar	7.5 bar	6.8 bar	6.5 bar
	PN 16	14.7 bar	12.1 bar	11.0 bar	10.6 bar
	PN 25	23 bar	18.9 bar	17.2 bar	16.6 bar
	PN 40	36.8 bar	30.3 bar	27.5 bar	26.5 bar

*(1) Liner temperature limits must also be considered.*

### A.3.2 Physical specifications

Rosemount magnetic flow meters are designed to the standards defined in ASME B31.3. This standard is used as the basis for all of our other pressure vessel certifications such as CRN and PED.

#### Non-wetted materials

Sensor Pipe	Type 304/304L SST or Type 316/316L SST
Flanges <sup>(1)</sup>	Flat-Face (FF) and Raised-Face (RF)
Coil housing	Rolled carbon steel or 300 series stainless steel
Remote junction box	Painted aluminum
Paint	Polyurethane coat (2.6 mils or greater)
Optional coil housing	316/316L unpainted, option code SH
Optional remote junction box	316/316L, unpainted, option code SJ; included with option code SH

*(1) Ambient temperature low limit for A105 carbon steel is -20 °F (-29 °C) per ANSI B16.5. For colder ambient environments, stainless steel flanges must be used.*

#### Process-wetted materials

Flanges <sup>(1)</sup>	Ring Type Joint (RTJ)
Lining	PTFE, ETFE, PFA, Polyurethane, Neoprene, Linatex, Adiprene, PFA+
Electrodes	316L SST, Nickel Alloy 276 (UNS N10276), Tantalum, 80% Platinum-20% Iridium, Titanium

*(1) Ambient temperature low limit for A105 carbon steel is -20 °F (-29 °C) per ANSI B16.5. For colder ambient environments, stainless steel flanges must be used.*

### Flat-faced flanges

Sensors ordered with flat-faced flanges and Neoprene or Linatex liners are manufactured with the liner extending to the outer dimension of the flange. All other liner selections extend to the diameter of raised face dimension and create a raised surface on the flange face.

### Process connections

ASME B16.5	<ul style="list-style-type: none"> <li>Class 150 and Class 300: ½ inch to 24 inch (15 mm to 600 mm)</li> <li>Class 600: ½ inch to 24 inch (15 mm to 600 mm)<sup>(1)</sup></li> <li>Class 900: 1 inch to 12 inch (25 mm to 300 mm)<sup>(2)</sup></li> <li>Class 1500: 1½ inch to 12 inch (40 mm to 300 mm)<sup>(2)</sup></li> <li>1½ inch to 6 inch (40 mm to 150 mm)<sup>(2)</sup></li> </ul>
ASME B16.47	<ul style="list-style-type: none"> <li>Class 150: 30 inch to 36 inch (750 mm to 900 mm)</li> <li>Class 300: 30 inch to 36 inch (750 mm to 900 mm)</li> </ul>
AWWA C207	<ul style="list-style-type: none"> <li>Class D: 30 inch and 36 inch (750 mm and 900 mm)</li> </ul>
MSS SP44	<ul style="list-style-type: none"> <li>Class 150: 30 inch to 36 inch (750 mm to 900 mm)</li> </ul>
EN 1092-1	<ul style="list-style-type: none"> <li>PN10: 200 mm to 900 mm (8 inch to 36 inch)</li> <li>PN16: 100 mm to 900 mm (4 inch to 36 inch)</li> <li>PN25: 200 mm to 900 mm (8 inch to 36 inch)</li> <li>PN40: 15 mm to 900 mm (½ inch to 36 inch)</li> </ul>
AS2129	<ul style="list-style-type: none"> <li>Table D and Table E: 15 mm to 900 mm (½ inch to 36 inch)</li> </ul>
AS4087	<ul style="list-style-type: none"> <li>PN16, PN21, PN35: 50 mm to 600 mm (2 inch to 24 inch)</li> </ul>
JIS B2220	<ul style="list-style-type: none"> <li>10K, 20K, 40K: 15 mm to 200 mm (½ inch to 8 inch)</li> </ul>

(1) For PTFE, PFA, PFA+, and ETFE, maximum working pressure is derated to 1000 psig.

(2) For Class 900 and higher flange ratings, liner selection is limited to resilient liners.

### Electrical connections

Conduit entries	Available with ½ inch NPT and M20
Terminal block screws	6-32 (No. 6) suitable for up to 14 AWG wire
Safety grounding screws	External stainless assembly, M5; internal 8-32 (No. 8)

### Process reference electrode (optional)

A process reference electrode can be installed similarly to the measurement electrodes through the sensor lining. It will be made of the same material as the measurement electrodes.

### Grounding rings (optional)

Grounding rings can be installed between the flange and the sensor face on both ends of the sensor. Single ground rings can be installed on either end of the sensor. They have an I.D. slightly larger than the sensor I.D. and an external tab to attach ground straps. Grounding rings are available in 316L SST, Nickel Alloy 276 (UNS N10276), titanium, and tantalum. See Product Data Sheet.

#### Lining protectors (optional)

Lining protectors can be installed between the flange and the sensor face on both ends of the sensor. The leading edge of lining material is protected by the lining protector; lining protectors cannot be removed once they are installed. Lining protectors are available in 316L SST, Nickel Alloy 276 (UNS N10276), and titanium. See Product Data Sheet.

#### Dimensions

See Product Data Sheet.

#### Weight

See Product Data Sheet.

## A.4 8711-M/L Wafer Sensor Specifications



### A.4.1 Functional specifications

#### Service

Conductive liquids and slurries

#### Line sizes

1.5-in. to 8-in. (40 mm to 200 mm)

#### Sensor coil resistance

10 - 18  $\Omega$

#### Interchangeability

Rosemount 8711-M/L Sensors are interchangeable with 8712EM and 8732EM Transmitters. System accuracy is maintained regardless of line size or optional features. Each sensor nameplate has a sixteen-digit calibration number that can be entered into a transmitter during configuration.

#### Upper range limit

39.37 ft/s (12 m/s)

#### Process temperature limits

ETFE lining	-20 to 300 °F (-29 to 149 °C)
PTFE lining	-20 to 350 °F (-29 to 177 °C)

#### Ambient temperature limits

-20 to 140 °F (-29 to 60 °C)

### Maximum safe working pressure at 100 °F (38 °C)

ETFE lining	Full vacuum to 740 psi (5.1 MPa)
PTFE lining	<ul style="list-style-type: none"> <li>Line sizes 1.5-in. (40 mm) through 4-in. (100 mm); Full vacuum to 740 psi (5.1 MPa)</li> <li>Consult Technical Support for vacuum applications with line sizes of 6-in. (150 mm) or larger</li> </ul>

### Submergence protection IP68

The remote mount sensor is rated IP68 for continuous submergence. Tested to a depth of 33 ft (10 m) for a period of 48 hours. IP68 rating requires that the transmitter must be remote mount. Installer must use IP68 approved cable glands, conduit connections, and/or conduit plugs.

### Conductivity limits

Process liquid must have a minimum conductivity of 5 microSiemens/cm (5 micromhos/cm) or greater for 8711.

## A.4.2 Physical specifications

### Non-wetted materials

Sensor body	<ul style="list-style-type: none"> <li>303 SST</li> <li>CF3M or CF8M</li> <li>Type 304/304L</li> </ul>
Coil housing	Rolled carbon steel
Remote junction box	Painted aluminum
Paint	Polyurethane coat (2.6 mils or greater)

### Process-wetted materials

Lining	PTFE, ETFE
Electrodes	316L SST, Nickel Alloy 276 (UNS N10276), Tantalum, 80% Platinum—20% Iridium, Titanium

### Electrical connections

Conduit entries	Available with ½ inch NPT and M20. See ordering table footnotes for details
Terminal block screws	6-32 (No. 6) suitable for up to 14 AWG wire
Safety grounding screws	External stainless assembly, M5; internal 8-32 (No. 8)

### Process reference electrode (optional)

A process reference electrode can be installed similarly to the measurement electrodes through the sensor lining. It will be made of the same material as the measurement electrodes.

### Grounding rings (optional)

Grounding rings can be installed between the flange and the sensor face on both ends of the sensor. They have an I.D. slightly smaller than the sensor I.D. and an external tab to attach ground wiring. Grounding rings are available in 316L SST, Nickel Alloy 276 (UNS N10276), titanium, and tantalum.

### Dimensions

See Product Data Sheet.

### Weight

See Product Data Sheet.

### Process connections—Mounts between these flange configurations

ASME B16.5	Class 150, 300
EN 1092-1	PN10, PN16, PN25, PN40
JIS B2220	10K, 20K
AS4087	PN16, PN21, PN35

### Studs, nuts, and washers—MK2-carbon steel

Component	ASME B16.5	EN1092-1
Studs, full thread	CS, ASTM A193, Grade B7	CS, ASTM A193, Grade B7
Hex nuts	ASTM A194 Grade 2H	ASTM A194 Grade 2H; DIN 934 H = D
Flat washers	CS, Type A, Series N, SAE per ANSI B18.2.1	CS, DIN 125
All items	Clear, chromate zinc-plated	Yellow zinc-plated

### Studs, nuts, and washers—MK3-316 SST

Component	ASME B16.5	EN1092-1
Studs, full thread	ASTM A193, Grade B8M Class 1	ASTM A193, Grade B8M Class 1
Hex nuts	ASTM A194 Grade 8M	ASTM A194 Grade 8M; DIN 934 H = D
Flat washers	316 SST, Type A, Series N, SAE per ANSI B18.2.1	316 SST, DIN 125

## A.5 8721 Hygienic (Sanitary) Sensor Specifications



## A.5.1 Functional specifications

### Service

Conductive liquids and slurries

### Line sizes

½ -in. to 4-in. (15 mm to 100 mm)

### Sensor coil resistance

5 -10 Ω

### Interchangeability

Rosemount 8721 sensors are interchangeable with Rosemount 8712EM and 8732EM transmitters. System accuracy is maintained regardless of line size or optional features. Each sensor label has a 16 digit calibration number that can be entered into the transmitter during configuration.

### Conductivity limits

Process liquid must have a minimum conductivity of 5 microSiemens/cm (5 micromhos/cm) or greater. Excludes the effect of interconnecting cable length in remote mount transmitter installations.

### Flow rate range

Capable of processing signals from fluids that are traveling between 0.04 and 39 ft/s (0.01 to 12 m/s) for both forward and reverse flow in all sensor sizes. Full scale continuously adjustable between -39 and 39 ft/s (-12 to 12 m/s).

### Sensor ambient temperature limits

14 to 140 °F (-15 to 60 °C)

### Process temperature limits

**PFA lining** -20 to 320 °F (-29 to 160 °C)

**Table A-12: Pressure limits**

Line size	Max working pressure	CE mark max. working pressure
½ -in. (15 mm)	300 psi (20.7 bar)	300 psi (20.7 bar)
1-in. (25 mm)	300 psi (20.7 bar)	300 psi (20.7 bar)
1 ½ -in. (40 mm)	300 psi (20.7 bar)	300 psi (20.7 bar)
2-in. (50 mm)	300 psi (20.7 bar)	300 psi (20.7 bar)
2 ½ -in. (65 mm)	300 psi (20.7 bar)	240 psi (16.5 bar)
3 -in. (80 mm)	300 psi (20.7 bar)	198 psi (13.7 bar)
4-in. (100 mm)	210 psi (14.5 bar)	148 psi (10.2 bar)

### Vacuum limits

Full vacuum at maximum lining material temperature; consult Technical Support.

### Submergence protection IP68

The remote mount 8721 sensor is rated IP68 for submergence to a depth of 33 ft (10 m) for a period of 48 hours. IP68 rating requires that the transmitter must be remote mount. Installer must use IP68 approved cable glands, conduit connections, and/or conduit plugs.

## A.5.2 Physical specifications

### Mounting

Integrally mounted transmitters are factory-wired and do not require interconnecting cables. The transmitter can rotate in 90° increments. Remote-mounted transmitters require only a single conduit connection to the sensor.

### Non-wetted materials

Sensor	304 Stainless Steel (wrapper), 304 Stainless Steel (pipe)
Terminal junction box	Low copper aluminum Optional: 304 Stainless Steel

### Process wetted materials (sensor)

Liner	PFA with Ra < 32µ in. (0.8 µm)
Electrodes	<ul style="list-style-type: none"> <li>316L SST with Ra &lt; 15µ in. (0.38 µm)</li> <li>Nickel Alloy 276 (UNS N10276) with Ra &lt; 15µ in. (0.38 µm)</li> <li>80% Platinum-20% Iridium with Ra &lt; 15µ in. (0.38 µm)</li> </ul>

### Process connections

The Rosemount 8721 Sanitary Sensor is designed using a standard IDF fitting as the basis for providing a flexible, hygienic interface for a variety of process connections. The Rosemount 8721 Sensor has the threaded or **male** end of the IDF fitting on the ends of the base sensor. The sensor can be directly connected with user supplied IDF fittings and gaskets. If other process connections are needed, the IDF fittings and gaskets can be provided and welded directly into the sanitary process tubing, or can be supplied with adapters to standard Tri Clamp process connections. All connections are PED compliant for group 2 fluids.

Tri Clamp sanitary coupling	<ul style="list-style-type: none"> <li>IDF Sanitary Coupling (screw type)</li> <li>IDF specification per BS4825 part 4</li> <li>ANSI Weld Nipple</li> <li>DIN 11850 Weld Nipple</li> <li>DIN 11851 (Imperial and Metric)</li> <li>DIN 11864-1 form A</li> <li>DIN 11864-2 form A</li> <li>SMS 1145</li> <li>Cherry-Burrell I-Line</li> </ul>
-----------------------------	--

#### Process connection material

- 316L Stainless Steel with Ra < 32µ in. (0.8 µm)
- Optional Electropolished Surface Finish with Ra < 15µ in. (0.38 µm)

#### Process connection gasket material

- Silicone
- EPDM
- Viton

#### Electrical connections

Conduit entries	½ -in. NPT standard, M20 adapters
Terminal block screws	M3
Safety grounding screws	External stainless assembly, M5; internal 6-32 (No. 6)

#### Dimensions

See Product Data Sheet.

#### Weight

**Table A-13: 8721 Sensor Weight**

Line size	Sensor only	008721-0350 Tri Clamp fitting (Each)
½ -in. (15 mm)	4.84 lbs (2.20 kg)	0.58 lbs (0.263 kg)
1-in. (25 mm)	4.52 lbs (2.05 kg)	0.68 lbs (0.309 kg)
1 ½ -in. (40 mm)	5.52 lbs (2.51 kg)	0.88 lbs (0.400 kg)
2-in. (50 mm)	6.78 lbs (3.08 kg)	1.30 lbs (0.591 kg)
2 ½ -in. (65 mm)	8.79 lbs (4.00 kg)	1.66 lbs (0.727 kg)
3 -in. (80 mm)	13.26 lbs (6.03 kg)	2.22 lbs (1.01 kg)
4-in. (100 mm)	21.04 lbs (9.56 kg)	3.28 lbs (1.49 kg)

Aluminum remote junction box	<ul style="list-style-type: none"> <li>• Approximately 1 lb. (0.45 kg)</li> <li>• Paint - Polyurethane (1.3 to 5 mils)</li> </ul>
SST remote junction box	<ul style="list-style-type: none"> <li>• Approximately 2.5 lbs. (1.13 kg)</li> <li>• Unpainted</li> </ul>



## B Product certifications

For detailed approval certification information and installation drawings, please see the appropriate document listed below:

- Document number 00825-MA00-0001: *Rosemount 8700M Approval Document - IECEx and ATEX*
- Document number 00825-MA00-0002: *Rosemount 8700M Approval Document – Class Division*
- Document number 00825-MA00-0003: *Rosemount 8700M Approval Document - North America Zone*
- Document number 00825-MA00-0007: *Rosemount 8700M Approval Document - NEPSI EN Zone 1 China*



# C Modbus Coil and Register Map

Here is a complete listing of the registers and coils available in the transmitter. Configuration details for a particular register or coil can be found elsewhere in this manual.

**Table C-1: Modbus registers**

Register	Description	Parameter Type	Work Level Access	Write Protect?
1	Status Register 0 bit #0 - Sensor Out of Range bit #1 - Empty Pipe Condition Detected bit #2 - I/O Processor Failure bit #3 - Pulse Output, Out of Range bit #4 - Update Missed bit #5 - Output at Alarm Level bit #6 - Modbus Nonvolatile Memory Error bit #7 - Pulse Output Fixed bit #8 - EPROM Checksum Error bit #9 - NOVRAM Checksum Error bit #10 - RAM Checksum Error bit #11 - Factory NOVRAM Checksum Error bit #12 - Continuous Meter Verification Error bit #13 - PZR Output is Active bit #14 - Coil Drive Current is Zero bit #15 - Reverse Flow Rate Detected	U16	R	N
2	Status Register 1 bit #0 - Internal Flow Simulation Test Error bit #1 - Excess Auto Zero Correction, ZR too Low bit #2 - Excess Auto Zero Correction, ZR too High bit #3 - Auto Zero attempt with Nonzero flow bit #4 - Totalizer Limit Alert 1 bit #5 - Universal Trim Failure bit #6 - Flow Limit Alert 1 bit #7 - Flow Limit Alert 2 bit #8 - Electrode Coated Limit 1 bit #9 - Electrode Coated Limit 2 bit #10 - Excess Calibration Correction, GN too Low bit #11 - Excess Calibration Correction, GN too High bit #12 - Calibration Attempt Without Calibrator bit #13 - Grounding/Wiring Fault bit #14 - High Process Noise Detected bit #15 - Electronics Temperature Out of Range	U16	R	N

Table C-1: Modbus registers (continued)

Register	Description	Parameter Type	Work Level Access	Write Protect?
3	Status Register 2 bit #0 - Digital I/O 1 Active bit #1 - Digital Output 2 Active bit #2 - Diagnostic Status Alert Active bit #3 - Modbus in Listen Only mode bit #4 - I/O Processor Comm Failure bit #5 - Coil Over Current Detected bit #6 - Sensor Electrode Saturated bit #7 - Coil Power Limit bit #8 - Electronics Failure bit #9 - Coil Resistance Error bit #10 - Coil Inductance Error bit #11 - Digital Trim Failure bit #12 - Reverse Flow Detected bit #13 - Electrode Resistance Error bit #14 - Auto Zero Failure bit #15 - Reserved for Status bit	U16	R	N
5	Transmitter State Register bit #0 - Write Protect Code bit #1 - Update In Progress bits #2 - #15 Reserved	U16	R	N
16	Transmitter software revision - (xxxx.x format, e.g., 141 means rev 14.1)	U16	R	N
17	MODBUS Module software revision	U16	R	N
18	Display Type	U8	R	N
20	Internal Flow Simulator Value units	U8	R	N
21	Internal Flow Simulator Deviation units	U8	R	N
22	Coil Inductance Deviation Units	U8	R	N
23	Coil Inductance Units	U8	R	N
24	Coil Resistance Units	U8	R	N
25	Electrode Resistance Units	U8	R	N
26	Electrode Coating Resistance Unit	U8	R	N
27	Empty Pipe Value Units	U8	R	N
28	Electronics Temperature Units	U8	R	N
29	Process Density Units	U8	R	N
30	Flowmeter Verification Test summary result	U8	R	N
31	Coil Inductance Test Result	U8	R	N
32	Coil Resistance Test Result	U8	R	N
33	Electrode Resistance Test Result	U8	R	N
34	Internal Simulator Test Result	U8	R	N

**Table C-1: Modbus registers (continued)**

Register	Description	Parameter Type	Work Level Access	Write Protect?
35	Test limits the Flowmeter Verification Test was run against	U8	R	N
36	Test Condition of the Flowmeter Verification Test	U8	R	N
37	Pulse Scale Factor Units	U8	R	N
61	Flow Units	U8	RW	Y
62	Totalizer A Units	U8	RW	Y
63	Totalizer B Units	U8	RW	Y
64	Totalizer C Units	U8	RW	Y
65	Sensor line size	U8	RW	Y
66	Electrode Material Code	U8	RW	Y
67	Electrode Type Code	U8	RW	Y
68	Transmitter Tag	A8	RW	Y
72	Flange Material Code	U8	RW	Y
73	Flange Type	U8	RW	Y
74	Liner Material Code	U8	RW	Y
75	Base Time Units Code for Special Units	U8	RW	Y
76	Base Reference Units Code for Special Units	U8	RW	Y
77	Coil Drive Frequency	U8	RW	Y
78	Signal Processing Status	U8	RW	Y
79	Digital Signal Processing Operating Mode	U8	RW	Y
80	Signal Processing Number of Samples	U16	RW	Y
81	Flow Display Configuration	U8	RW	Y
83	LOI Language Configuration	U8	RW	Y
84	LOI Display Auto Lock Configuration	U8	RW	Y
85	Pulse Output Mode.	U8	RW	Y
86	Empty Pipe Trigger Counts	U8	RW	Y
87	Flowmeter Verification Limit – Empty Pipe condition	U8	RW	Y
88	Flowmeter Verification Limit – Flowing condition	U8	RW	Y
89	Flowmeter Verification Limit – No Flow condition	U8	RW	Y
90	Continuous Meter Verification Test	U8	RW	Y
91	Discrete I/O 1 directional control	U8	RW	Y
92	Discrete I/O 1 input condition	U8	RW	Y
93	Discrete I/O 1 output condition	U8	RW	Y
96	Discrete I/O 2 output condition	U8	RW	Y
97	Flow Limit 1 Mode	U8	RW	Y
98	Flow Limit 2 Mode	U8	RW	Y

**Table C-1: Modbus registers (continued)**

Register	Description	Parameter Type	Work Level Access	Write Protect?
99	Totalizer Limit Mode	U8	RW	Y
100	Totalizer A - Reset Configuration	U8	RW	Y
101	Totalizer A - Flow Direction Configuration	U8	RW	Y
102	Totalizer B - Reset Configuration	U8	RW	Y
103	Totalizer B - Flow Direction Configuration	U8	RW	Y
104	Totalizer C - Reset Configuration	U8	RW	Y
105	Totalizer C - Flow Direction Configuration	U8	RW	Y
106	Sensor Signature Select	U8	RW	Y
107	Meter Verification Test Scope (Test Input)	U8	RW	N
108	Meter Verification Test Condition (Test Input)	U8	RW	N
109	MODBUS Device Address	U8	RW	Y
110	Floating Point Byte Order	U8	RW	Y
111	Minimum Modbus Response Delay	U8	RW	Y
114	Modbus Protocol	U8	R	N
115	Modbus Baud Rate	U8	RW	Y
116	Modbus Parity	U8	RW	Y
117	Modbus Stop Bits	U8	RW	Y
119	LOI Auto Lock Time	U8	RW	Y
120	Manufacturers Device Type Code	U8	R	N
121	Manufacturers Id Code	U8	R	N
122	LOI Backlight Control Configuration	U8	RW	Y
151	Device Identification Number	U32	R	N
153	Primary Variable Sensor Serial Number	U32	RW	Y
155	Final Assembly Number	U32	RW	Y
157	Diagnostic License Key	U32	RW	Y

**Table C-1: Modbus registers (continued)**

Register	Description	Parameter Type	Work Level Access	Write Protect?
197	Status Register 0 bit #0 - Sensor Out of Range bit #1 - Empty Pipe Condition Detected bit #2 - I/O Processor Failure bit #3 - Pulse Output, Out of Range bit #4 - Update Missed bit #5 - Output at Alarm Level bit #6 - Modbus Nonvolatile Memory Error bit #7 - Pulse Output Fixed bit #8 - EPROM Checksum Error bit #9 - NOVRAM Checksum Error bit #10 - RAM Checksum Error bit #11 - Factory NOVRAM Checksum Error bit #12 - Continuous Meter Verification Error bit #13 - PZR Output is Active bit #14 - Coil Drive Current is Zero bit #15 - Reverse Flow Rate Detected	U16	R	N
198	Status Register 1 bit #0 - Internal Flow Simulation Test Error bit #1 - Excess Auto Zero Correction, ZR too Low bit #2 - Excess Auto Zero Correction, ZR too High bit #3 - Auto Zero attempt with Nonzero flow bit #4 - Totalizer Limit Alert 1 bit #5 - Universal Trim Failure bit #6 - Flow Limit Alert 1 bit #7 - Flow Limit Alert 2 bit #8 - Electrode Coated Limit 1 bit #9 - Electrode Coated Limit 2 bit #10 - Excess Calibration Correction, GN too Low bit #11 - Excess Calibration Correction, GN too High bit #12 - Calibration Attempt Without Calibrator bit #13 - Grounding/Wiring Fault bit #14 - High Process Noise Detected bit #15 - Electronics Temperature Out of Range	U16	R	N

Table C-1: Modbus registers (continued)

Register	Description	Parameter Type	Work Level Access	Write Protect?
199	Status Register 2 bit #0 - Digital I/O 1 Active bit #1 - Digital Output 2 Active bit #2 - Diagnostic Status Alert Active bit #3 - Modbus in Listen Only mode bit #4 - I/O Processor Comm Failure bit #5 - Coil Over Current Detected bit #6 - Sensor Electrode Saturated bit #7 - Coil Power Limit bit #8 - Electronics Failure bit #9 - Coil Resistance Error bit #10 - Coil Inductance Error bit #11 - Digital Trim Failure bit #12 - Reverse Flow Detected bit #13 - Electrode Resistance Error bit #14 - Auto Zero Failure bit #15 - Reserved for Status bit	U16	R	N
201	Flow rate	F32	R	N
203	Totalizer A Value	F32	R	N
205	Totalizer B Value	F32	R	N
207	Totalizer C Value	F32	R	N
209	Electronics Temperature Value	F32	R	N
211	Line Noise Value	F32	R	N
213	5 Hz Signal to Noise Ratio (Value)	F32	R	N
215	37 Hz Signal to Noise Ratio (Value)	F32	R	N
217	Signal Power	F32	R	N
219	Empty Pipe Value	F32	R	N
221	Electrode Coating Value	F32	R	N
223	Internal Flow Simulator Percent Deviation (Continuous Meter Verification)	F32	R	N
225	Electrode Resistance Value (Continuous Meter Verification)	F32	R	N
227	Coil Resistance Value (Continuous Meter Verification)	F32	R	N
229	Coil Inductance Value (Continuous Meter Verification)	F32	R	N
231	Coil Inductance Deviation (Continuous Meter Verification)	F32	R	N
233	Pulse Output Value	F32	R	N
235	Internal Flow Simulator Value (Continuous Meter Verification)	F32	R	N
237	Coil Current	F32	R	N



**Table C-1: Modbus registers (continued)**

Register	Description	Parameter Type	Work Level Access	Write Protect?
261	Primary Variable Lower Sensor Limit	F32	R	N
263	Primary Variable Upper Sensor Limit	F32	R	N
267	Internal Flow Simulator Reference Value	F32	R	N
269	Internal Flow Simulator Value (Manual Meter Verification)	F32	R	N
271	Internal Flow Simulator Deviation (Manual Meter Verification)	F32	R	N
273	Coil Inductance Deviation (Manual Meter Verification)	F32	R	N
275	Coil Inductance value (Manual Meter Verification)	F32	R	N
277	Coil Resistance value (Manual Meter Verification)	F32	R	N
279	Electrode Resistance value (Manual Meter Verification)	F32	R	N
281	Electrode Coating Max Resistance Value	F32	R	N
283	Auto Zero Offset	F32	R	N
285	Coil Inductance Signature Value	F32	R	Y
287	Coil Resistance Signature Value	F32	R	Y
289	Electrode Resistance Signature Value	F32	R	Y
321	Flow Damping Value	F32	RW	Y
323	Conversion Factor for Special Units	F32	RW	Y
325	Low Flow Cutoff Value	F32	RW	Y
327	Pulse Scaling Factor	F32	RW	Y
329	Pulse Output Width (milliseconds)	F32	RW	Y
331	Universal Flow Rate	F32	RW	Y
333	Process Density Value	F32	RW	Y
335	Empty Pipe Trigger Level	F32	RW	Y
337	Flow Limit 1 High Value	F32	RW	Y
339	Flow Limit 1 Low Value	F32	RW	Y
341	Flow Limit 2 High Value	F32	RW	Y
343	Flow Limit 2 Low Value	F32	RW	Y
345	Flow Limit Hysteresis	F32	RW	Y
347	Totalizer High Limit Value	F32	RW	Y
349	Totalizer Low Limit Value	F32	RW	Y
351	Totalizer Hysteresis Limit	F32	RW	Y
353	Electrode Coating Threshold Level 1	F32	RW	Y
355	Electrode Coating Threshold Level 2	F32	RW	Y
359	Fixed Pulse Output Value (Write a 0 to clear)	F32	RW	Y

**Table C-1: Modbus registers (continued)**

Register	Description	Parameter Type	Work Level Access	Write Protect?
361	Signal Processing Percent Limit	F32	RW	Y
363	Signal Processing Time Limit	F32	RW	Y
409	Special Flow Rate Unit	A4	RW	Y
411	Special Volume Unit	A4	RW	Y
413	Sensor Calibration Number	A16	RW	Y
421	Long Tag	A32	RW	Y
437	Message	A32	RW	Y
453	Flow Tube Tag	A8	RW	Y
457	Descriptor	A16	RW	Y
651	Slot 0 Transmitter Variable Index	U8	RW	Y
652	Slot 1 Transmitter Variable Index	U8	RW	Y
653	Slot 2 Transmitter Variable Index	U8	RW	Y
654	Slot 3 Transmitter Variable Index	U8	RW	Y
655	Slot 4 Transmitter Variable Index	U8	RW	Y
656	Slot 5 Transmitter Variable Index	U8	RW	Y
657	Slot 6 Transmitter Variable Index	U8	RW	Y
658	Slot 7 Transmitter Variable Index	U8	RW	Y
659	Slot 8 Transmitter Variable Index	U8	RW	Y
660	Slot 9 Transmitter Variable Index	U8	RW	Y
661	Slot 10 Transmitter Variable Index	U8	RW	Y
662	Slot 11 Transmitter Variable Index	U8	RW	Y
663	Slot 12 Transmitter Variable Index	U8	RW	Y
664	Slot 13 Transmitter Variable Index	U8	RW	Y
665	Slot 14 Transmitter Variable Index	U8	RW	Y
666	Slot 15 Transmitter Variable Index	U8	RW	Y
667	Slot 16 Transmitter Variable Index	U8	RW	Y
668	Slot 17 Transmitter Variable Index	U8	RW	Y
669	Slot 18 Transmitter Variable Index	U8	RW	Y
670	Slot 19 Transmitter Variable Index	U8	RW	Y
671	Slot 20 Transmitter Variable Index	U8	RW	Y
672	Slot 21 Transmitter Variable Index	U8	RW	Y
673	Slot 22 Transmitter Variable Index	U8	RW	Y
674	Slot 23 Transmitter Variable Index	U8	RW	Y
675	Slot 24 Transmitter Variable Index	U8	RW	Y
676	Slot 25 Transmitter Variable Index	U8	RW	Y

**Table C-1: Modbus registers (continued)**

Register	Description	Parameter Type	Work Level Access	Write Protect?
677	Slot 26 Transmitter Variable Index	U8	RW	Y
678	Slot 27 Transmitter Variable Index	U8	RW	Y
679	Slot 28 Transmitter Variable Index	U8	RW	Y
680	Slot 29 Transmitter Variable Index	U8	RW	Y
687	Status Register 0 bit #0 - Sensor Out of Range bit #1 - Empty Pipe Condition Detected bit #2 - I/O Processor Failure bit #3 - Pulse Output, Out of Range bit #4 - Update Missed bit #5 - Output at Alarm Level bit #6 - Modbus Nonvolatile Memory Error bit #7 - Pulse Output Fixed bit #8 - EPROM Checksum Error bit #9 - NOVRAM Checksum Error bit #10 - RAM Checksum Error bit #11 - Factory NOVRAM Checksum Error bit #12 - Continuous Meter Verification Error bit #13 - PZR Output is Active bit #14 - Coil Drive Current is Zero bit #15 - Reverse Flow Rate Detected	U16	R	N
688	Status Register 1 bit #0 - Internal Flow Simulation Test Error bit #1 - Excess Auto Zero Correction, ZR too Low bit #2 - Excess Auto Zero Correction, ZR too High bit #3 - Auto Zero attempt with Nonzero flow bit #4 - Totalizer Limit Alert 1 bit #5 - Universal Trim Failure bit #6 - Flow Limit Alert 1 bit #7 - Flow Limit Alert 2 bit #8 - Electrode Coated Limit 1 bit #9 - Electrode Coated Limit 2 bit #10 - Excess Calibration Correction, GN too Low bit #11 - Excess Calibration Correction, GN too High bit #12 - Calibration Attempt Without Calibrator bit #13 - Grounding/Wiring Fault bit #14 - High Process Noise Detected bit #15 - Electronics Temperature Out of Range	U16	R	N

**Table C-1: Modbus registers (continued)**

Register	Description	Parameter Type	Work Level Access	Write Protect?
689	Status Register 2 bit #0 - Digital I/O 1 Active bit #1 - Digital Output 2 Active bit #2 - Diagnostic Status Alert Active bit #3 - Modbus in Listen Only mode bit #4 - I/O Processor Comm Failure bit #5 - Coil Over Current Detected bit #6 - Sensor Electrode Saturated bit #7 - Coil Power Limit bit #8 - Electronics Failure bit #9 - Coil Resistance Error bit #10 - Coil Inductance Error bit #11 - Digital Trim Failure bit #12 - Reverse Flow Detected bit #13 - Electrode Resistance Error bit #14 - Auto Zero Failure bit #15 - Reserved for Status bit	U16	R	N
691	Slot 0 Transmitter Variable	F32	R	N
693	Slot 1 Transmitter Variable	F32	R	N
695	Slot 2 Transmitter Variable	F32	R	N
697	Slot 3 Transmitter Variable	F32	R	N
699	Slot 4 Transmitter Variable	F32	R	N
701	Slot 5 Transmitter Variable	F32	R	N
703	Slot 6 Transmitter Variable	F32	R	N
705	Slot 7 Transmitter Variable	F32	R	N
707	Slot 8 Transmitter Variable	F32	R	N
709	Slot 9 Transmitter Variable	F32	R	N
711	Slot 10 Transmitter Variable	F32	R	N
713	Slot 11 Transmitter Variable	F32	R	N
715	Slot 12 Transmitter Variable	F32	R	N
717	Slot 13 Transmitter Variable	F32	R	N
719	Slot 14 Transmitter Variable	F32	R	N
721	Slot 15 Transmitter Variable	F32	R	N
723	Slot 16 Transmitter Variable	F32	R	N
725	Slot 17 Transmitter Variable	F32	R	N
727	Slot 18 Transmitter Variable	F32	R	N
729	Slot 19 Transmitter Variable	F32	R	N
731	Slot 20 Transmitter Variable	F32	R	N
733	Slot 21 Transmitter Variable	F32	R	N
735	Slot 22 Transmitter Variable	F32	R	N

**Table C-1: Modbus registers (continued)**

Register	Description	Parameter Type	Work Level Access	Write Protect?
737	Slot 23 Transmitter Variable	F32	R	N
739	Slot 24 Transmitter Variable	F32	R	N
741	Slot 25 Transmitter Variable	F32	R	N
743	Slot 26 Transmitter Variable	F32	R	N
745	Slot 27 Transmitter Variable	F32	R	N
747	Slot 28 Transmitter Variable	F32	R	N
749	Slot 29 Transmitter Variable	F32	R	N
1137	Attached Core Software revision	U16	R	N
1138	Board Type (see board type codes table)	U16	R	N
1162	Device Type Code for attached Core	U8	R	N

**Table C-2: Modbus coils**

Register	Description	Parameter Type	Work Level Access	Write Protect?
1	Sensor Out of Range	U8	R	N
2	Empty Pipe Condition Detected	U8	R	N
3	I/O Processor Failure	U8	R	N
4	Pulse Output, Out of Range	U8	R	N
5	Update Missed	U8	R	N
6	Output at Alarm Level	U8	R	N
7	Modbus Nonvolatile Memory Error	U8	R	N
8	Pulse Output Fixed	U8	R	N
9	EPROM Checksum Error	U8	R	N
10	NOVRAM Checksum Error	U8	R	N
11	RAM Checksum Error	U8	R	N
12	Factory NOVRAM Checksum Error	U8	R	N
13	Continuous Meter Verification Error	U8	R	N
14	PZR Output is Active	U8	R	N
15	Coil Drive Current is Zero	U8	R	N
16	Reverse Flow Rate Detected	U8	R	N
17	Internal Flow Simulation Test Error	U8	R	N
18	Excess Auto Zero Correction, ZR too Low	U8	R	N
19	Excess Auto Zero Correction, ZR too High	U8	R	N
20	Auto Zero attempt with Nonzero flow	U8	R	N
21	Totalizer Limit Alert 1	U8	R	N
22	Universal Trim Failure	U8	R	N

Table C-2: Modbus coils (continued)

Register	Description	Parameter Type	Work Level Access	Write Protect?
23	Flow Limit Alert 1	U8	R	N
24	Flow Limit Alert 2	U8	R	N
25	Electrode Coated Limit 1	U8	R	N
26	Electrode Coated Limit 2	U8	R	N
27	Excess Calibration Correction. GN too Low	U8	R	N
28	Excess Calibration Correction, GN too High	U8	R	N
29	Calibration Attempt Without Calibrator	U8	R	N
30	Grounding/Wiring Fault	U8	R	N
31	High Process Noise Detected	U8	R	N
32	Electronics Temperature Out of Range	U8	R	N
33	Digital I/O 1 Active	U8	R	N
34	Digital Output 2 Active	U8	R	N
35	Diagnostic Status Alert Active	U8	R	N
36	Modbus in Listen Only mode	U8	R	N
37	I/O Processor Comm Failure	U8	R	N
38	Coil Over Current Detected	U8	R	N
39	Sensor Electrode Saturated	U8	R	N
40	Coil Power Limit	U8	R	N
41	Electronics Failure	U8	R	N
42	Coil Resistance Error	U8	R	N
43	Coil Inductance Error	U8	R	N
44	Digital Trim Failure	U8	R	N
45	Reverse Flow Detected	U8	R	N
46	Electrode Resistance Error	U8	R	N
47	Auto Zero Failure	U8	R	N
65	Write Protect Switch State	U8	R	N
66	Update In Progress	U8	R	N
67	License Status - High Process Noise	U8	R	N
68	License Status - Grounding/Wiring	U8	R	N
69	License Status - Digital I/O	U8	R	N
70	License Status - Meter Verification	U8	R	N
71	License Status - Electrode Coating	U8	R	N
97	Enable/Disable Flow Limit Alert 1	U8	RW	Y
98	Enable/Disable Flow Limit Alert 2	U8	RW	Y
99	Enable/Disable Reverse Flow	U8	RW	Y

**Table C-2: Modbus coils (continued)**

Register	Description	Parameter Type	Work Level Access	Write Protect?
100	Lock/Unlock LOI	U8	RW	Y
101	Start/Stop All Totalizers	U8	RW	N
103	Reset All Totals	U8	RW	N
104	Reset Totalizer A	U8	RW	N
105	Reset Totalizer B	U8	RW	N
106	Reset Totalizer C	U8	RW	N
107	Enable/Disable Totalizer Limit Alert	U8	RW	Y
108	Perform Transmitter Self Test	U8	RW	N
109	Perform Electronics Trim	U8	RW	Y
110	Perform Auto Zero Trim	U8	RW	Y
111	Perform Universal Trim	U8	RW	Y
112	Perform Meter Verification	U8	RW	N
113	Perform Sensor Signature	U8	RW	Y
114	Perform Recall Last Saved Sensor Signature	U8	RW	Y
115	Perform Clear Electrode Coating Max Value	U8	RW	N
116	Perform Master Reset	U8	RW	Y
117	Enable/Disable Empty Pipe Detection	U8	RW	Y
118	Enable/Disable High Process Noise Detection	U8	RW	Y
119	Enable/Disable Grounding/Wiring Fault Detection	U8	RW	Y
120	Enable/Disable Electronics Temperature Detection	U8	RW	Y
121	Enable/Disable Electrode Coating Detection	U8	RW	Y
122	Enable/Disable Continuous Meter Verification Coil Test	U8	RW	Y
123	Enable/Disable Continuous Meter Verification Electrode Test	U8	RW	Y
124	Enable/Disable Continuous Meter Verification Transmitter Test	U8	RW	Y
126	Enable/Disable Diagnostic Status Alert - Electronics Failure	U8	RW	Y
127	Enable/Disable Diagnostic Status Alert - Coil Open Circuit	U8	RW	Y
128	Enable/Disable Diagnostic Status Alert - Empty Pipe	U8	RW	Y
129	Enable/Disable Diagnostic Status Alert - Reverse Flow	U8	RW	Y
130	Enable/Disable Diagnostic Status Alert - Ground/Wiring Fault	U8	RW	Y
131	Enable/Disable Diagnostic Status Alert - High Process Noise	U8	RW	Y

**Table C-2: Modbus coils (continued)**

Register	Description	Parameter Type	Work Level Access	Write Protect?
132	Enable/Disable Diagnostic Status Alert - Elect Temp Out of Range	U8	RW	Y
133	Enable/Disable Diagnostic Status Alert - Electrode Coating Limit 1	U8	RW	Y
134	Enable/Disable Diagnostic Status Alert - Electrode Coating Limit 2	U8	RW	Y
135	Enable/Disable Diagnostic Status Alert - Continuous Meter Verification	U8	RW	Y
136	Enable/Disable Diagnostic Status Alert - Coil Over Current	U8	RW	Y
137	Enable/Disable Diagnostic Status Alert - Sensor Electrode Saturated	U8	RW	Y
138	Enable/Disable Diagnostic Status Alert - Coil Power Limit	U8	RW	Y
139	Enable/Disable Totalizer Start/Stop Write Protect	U8	RW	Y
140	Enable/Disable Totalizer Reset Write Protect	U8	RW	Y
141	Enable/disable totalizer start/stop from LOI	U8	RW	Y
142	Enable/disable totalizer reset from LOI	U8	RW	Y





Figure D-2: Wiring 8732EM using combination cable

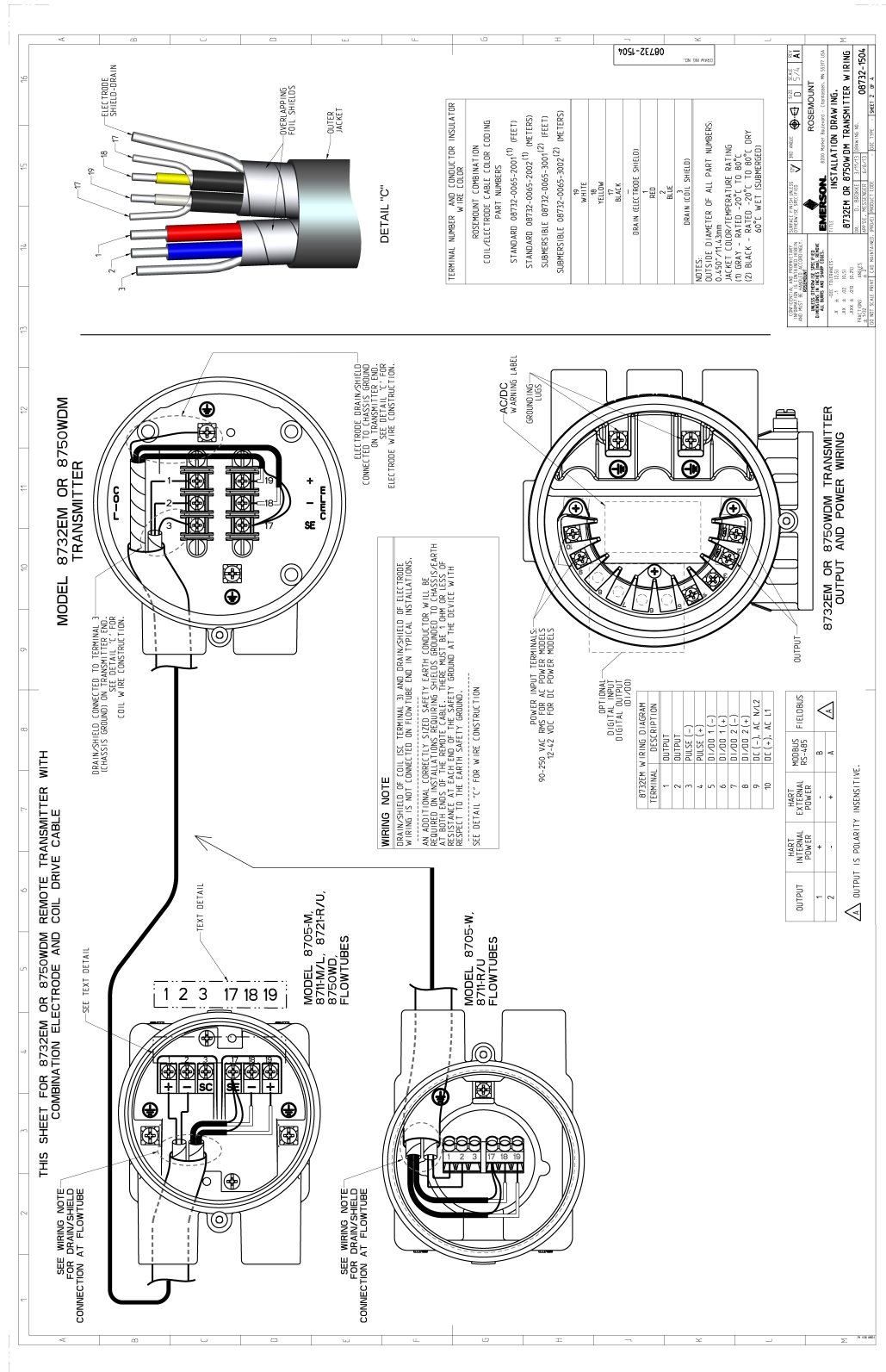

# E Implementing a Universal Transmitter

## E.1 Safety messages

Instructions and procedures in this section may require special precautions to ensure the safety of the personnel performing the operations. Please read the following safety messages before performing any operation described in this section.

### **⚠ WARNING**

The transmitter has not been evaluated for use with other manufacturers' magnetic flowmeter sensors in hazardous (Ex or Classified) areas. Special care should be taken by the end-user and installer that the transmitter meets the safety and performance requirements of the other manufacturer's equipment.

## E.2 Universal capability

The transmitter has the ability to drive other manufacturers' sensors. In addition to providing a flow measurement, all diagnostic functionality is available. This capability can provide additional information about the installation, the process, and the health of the sensor. Universal capabilities enable a common maintenance practice for all magnetic flowmeter installations and help reduce spares inventory of magnetic flowmeter transmitters.

This section provides wiring diagrams for connecting the transmitter to other manufacturers' sensors, and describes how to configure the universal capabilities.

## E.3 Three step process

There are three steps to implementing a universal transmitter:

### **Procedure**

1. Review the existing application. Verify that the existing sensor is in good working order, and that it is compatible with a universal transmitter.

Locate the wiring diagram (in this Appendix) that applies to your sensor. While the universal transmitter may be able to drive the existing sensor, if the sensor is not in good working order, the universal transmitter may not function correctly.

2. Connect the universal transmitter to the existing sensor using the appropriate wiring diagram from this appendix.

If the sensor you are using is not listed in this appendix, contact Emerson technical support for more details on the application of the universal capabilities.

3. Configure the transmitter following the guidelines in [Operation](#) and [Advanced Configuration Functionality](#), setting up parameters as needed.

One of the key configuration parameters is the sensor calibration number. There are several methods to determine the calibration number, but the most common method will be to use the universal trim capability. This functionality is detailed in

this appendix. Accuracy of the meter when the universal trim is used to determine the calibration number will be dependent on the accuracy of the known flow rate used in the trim process.

In addition to the universal trim, there are two other methodologies for determining a calibration number for the sensor:

Method 1: Have the sensor sent to a Rosemount service center for determination of a calibration number compatible with the universal transmitter. This is the most accurate method for determining the calibration number and will provide a  $\pm 0.5\%$  of rate measurement accuracy from 3 to 40 fps (1-10 m/s).

Method 2: Involves the conversion of the existing sensor calibration number / meter factors to an equivalent Rosemount 16-digit calibration number. Accuracy of the meter using this methodology is estimated to be in the range of 2-3%. Contact Emerson technical support for more information on this method or to determine a calibration number for the existing sensor.

Once these steps are completed, the meter will begin measuring flow. Verify the measured flow rate is within the expected range and that the output correctly corresponds to the measured flow rate. Also verify the reading in the control system matches the reading at the transmitter. Once these items have been verified, the loop can be placed into automatic control as needed.

### E.3.1 Universal trim

The universal auto trim function enables the transmitter to determine a calibration number for sensors that were not calibrated at the factory. See [Universal trim](#).

## E.4 Wiring the universal transmitter

The wiring diagrams in this section illustrate the proper connections between the transmitter and most sensors currently on the market. Specific diagrams are included for most models, and where information for a particular model of a manufacturer is not available, a generic drawing pertaining to that manufacturer's sensors is provided. If the manufacturer for the existing sensor is not included, see the drawing for generic connections.

Any trademarks used herein regarding sensors not manufactured by Rosemount are owned by the particular manufacturer of the sensor.

## E.5 Rosemount sensors

### E.5.1 8705/8707/8711/8721 Sensors to 8732 Transmitter

To connect a Rosemount 8705/8707/8711/8721 Sensor to a Rosemount 8732 Transmitter, connect coil drive and electrode cables as shown in [Figure E-1](#).

#### **⚠ CAUTION**

Do not connect mains or line power to the magnetic flowtube sensor or to the transmitter coil excitation circuit.

**Figure E-1: Wiring Diagram for a Rosemount 8732 Transmitter**

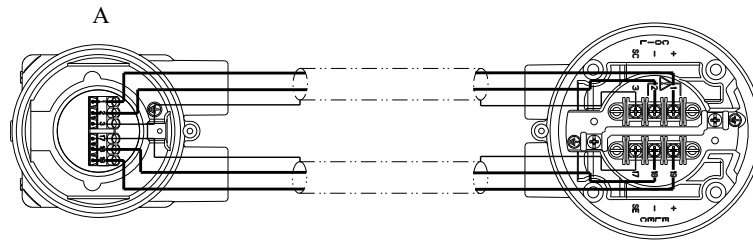

A. Rosemount 8732 transmitter

**Table E-1: Rosemount 8705/8707/8711/8721 Sensor Wiring Connections**

Rosemount 8732 Transmitters	Rosemount 8705/8707/8711/8721 Sensors
1	1
2	2
3	3
17	17
18	18
19	19

## E.5.2 8705 M and 8711 M/L Sensors to 8732EM Transmitter

To connect a Rosemount 8705 M or 8711 M/L Sensor to a Rosemount 8732EM Transmitter, connect coil drive and electrode cables as shown in [Figure E-2](#).

### **⚠ CAUTION**

Do not connect mains or line power to the magnetic flowtube sensor or to the transmitter coil excitation circuit.

**Figure E-2: Wiring Diagram for a Rosemount 8732EM Transmitter**

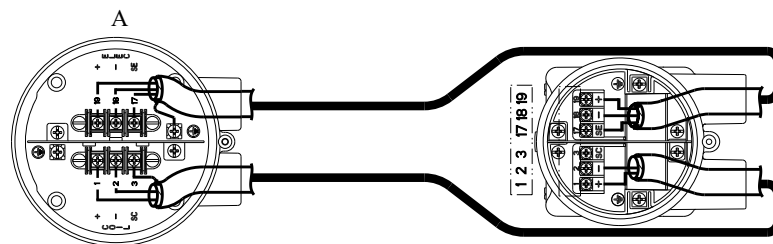

A. Rosemount 8732 transmitter

**Table E-2: Rosemount 8705/8711 Sensor Wiring Connections**

Rosemount 8732 Transmitters	Rosemount 8705/8711 Sensors
1	1 / +
2	2 / -
3	3 / SC
17	17 / SE
18	18 / -
19	19 / +

### E.5.3 8701 sensor to 8732 transmitter

To connect a Rosemount 8701 sensor to a Rosemount 8732 Transmitter, connect coil drive and electrode cables as shown in [Figure E-3](#).

#### **⚠ CAUTION**

Do not connect mains or line power to the magnetic flowtube sensor or to the transmitter coil excitation circuit.

**Figure E-3: Wiring Diagram for Rosemount 8701 Sensor and Rosemount 8732 Transmitter**

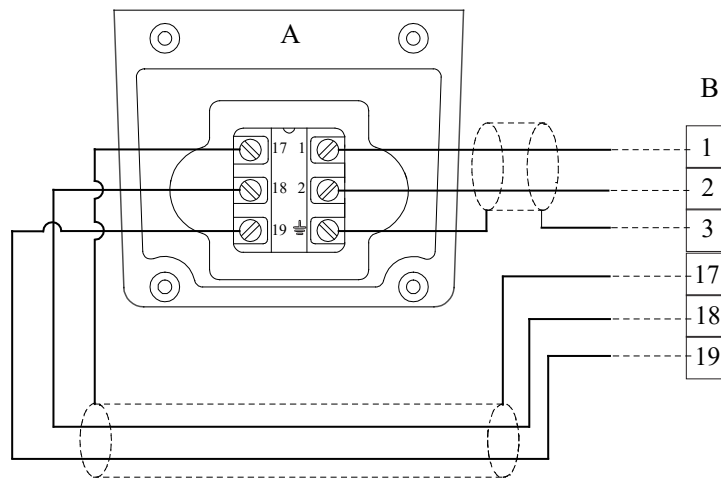

- A. Rosemount 8701 sensor
- B. Rosemount 8732 transmitter

#### **Note**

Refer to [Figure E-1](#) for actual terminal block configuration drawing.

**Table E-3: Rosemount 8701 Sensor Wiring Connections**

Rosemount 8732	Rosemount 8701 sensors
1	1
2	2

**Table E-3: Rosemount 8701 Sensor Wiring Connections (continued)**

Rosemount 8732	Rosemount 8701 sensors
3	3
17	17
18	18
19	19

## E.5.4 Connecting sensors of other manufacturers

### Prerequisites

Before connecting another manufacturer's sensor to the transmitter, it is necessary to perform the following functions.

#### **⚠ CAUTION**

Do not connect mains or line power to the magnetic flowtube sensor or to the transmitter coil excitation circuit.

### Procedure

1. Turn off the AC power to the sensor and transmitter.

#### **⚠ CAUTION**

Failure to do so could result in electrical shock or damage to the transmitter.

2. Verify the coil drive cables between the sensor and the transmitter are not connected to any other equipment.
3. Label the coil drive cables and electrode cables for connection to the transmitter.
4. Disconnect the wires from the existing transmitter.
5. Remove the existing transmitter and then mount the new transmitter.  
See [Remote Transmitter Installation](#).
6. Verify the sensor coil is configured for series connection.  
Other manufacturers sensors may be wired in either a series or parallel circuit. All Rosemount magnetic sensors are wired in a series circuit. (Other manufacturers AC sensors (AC coils) wired for 220 V operation are typically wired in parallel and must be rewired in series.)
7. Use the manufacturer's recommended test procedure for verification of sensor condition to verify the sensor is in good working condition. Perform the basic checks:
  - a) Check the coils for shorts or open circuits.
  - b) Check the sensor liner for wear or damage.
  - c) Check the electrodes for shorts, leaks, or damage.
8. Connect the sensor to the transmitter in accordance with reference wiring diagrams.  
See [Wiring Diagrams](#) for specific drawings.

9. Connect and verify all connections between the sensor and the transmitter, then apply power to the transmitter.
10. Perform the Universal Auto Trim function.

## E.6 Brooks sensors

### E.6.1 Model 5000 sensor to 8732 Transmitter

To connect a Model 5000 sensor to a Rosemount 8732 Transmitter, connect coil drive and electrode cables as shown in [Figure E-4](#).

#### ⚠ CAUTION

Do not connect mains or line power to the magnetic flowtube sensor or to the transmitter coil excitation circuit.

**Figure E-4: Wiring Diagram for Brooks Sensor Model 5000 and Rosemount 8732**

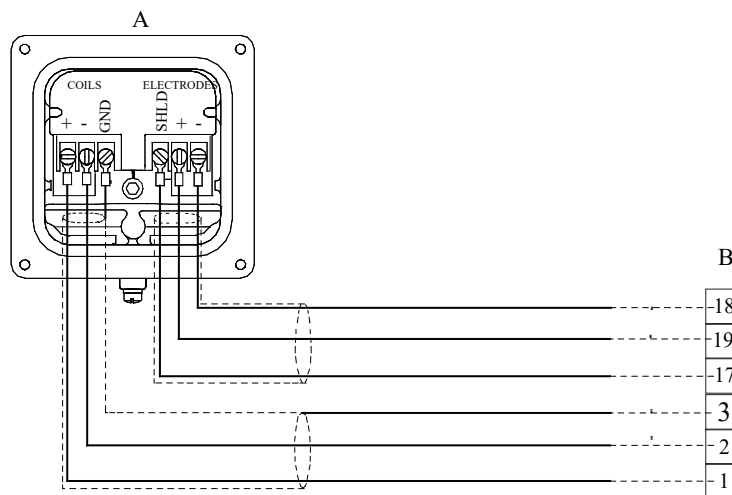

- A. Brooks Model 5000  
B. Rosemount 8732 transmitter

#### Note

Refer to [Figure E-1](#) for actual terminal block configuration drawing.

**Table E-4: Brooks Model 5000 Sensor Wiring Connections**

Rosemount 8732	Brooks sensors Model 5000
1	COILS (+)
2	COILS (-)
3	COILS (GND)
17	ELECTRODES (SHLD)
18	ELECTRODES (-)
19	ELECTRODES (+)



## E.6.2 Model 7400 sensor to 8732 Transmitter

To connect a Model 7400 sensor to a Rosemount 8732 Transmitter, connect coil drive and electrode cables as shown in [Figure E-5](#).

### ⚠ CAUTION

Do not connect mains or line power to the magnetic flowtube sensor or to the transmitter coil excitation circuit.

**Figure E-5: Wiring Diagram for Brooks Sensor Model 7400 and Rosemount 8732**

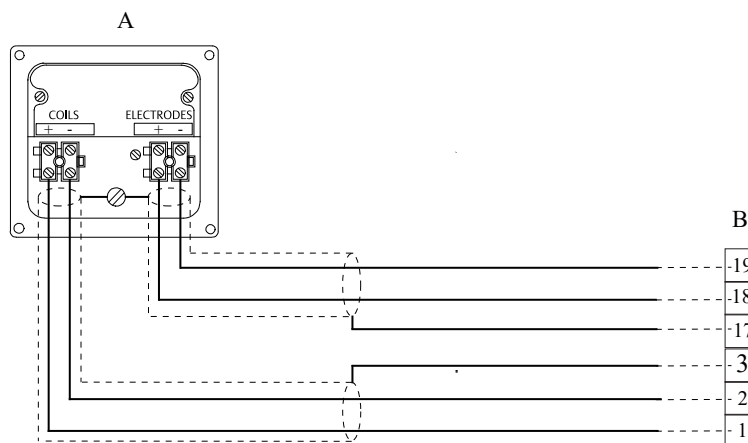

- A. Brooks Model 7400
- B. Rosemount 8732 transmitter

### Note

Refer to [Figure E-1](#) for actual terminal block configuration drawing.

**Table E-5: Brooks Model 7400 sensor Wiring Connections**

Rosemount 8732	Brooks Sensors Model 7400
1	Coils +
2	Coils -
3	3
17	Shield
18	Electrode +
19	Electrode -

## E.7 Endress and Hauser sensors

### E.7.1 Endress and Hauser sensor to 8732 Transmitter

To connect an Endress and Hauser sensor to a Rosemount 8732 Transmitter, connect coil drive and electrode cables as shown in [Figure E-6](#).

**⚠ CAUTION**

Do not connect mains or line power to the magnetic flowtube sensor or to the transmitter coil excitation circuit.

**Figure E-6: Wiring Diagram for Endress and Hauser Sensors and Rosemount 8732**

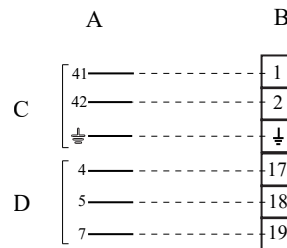

- A. Endress and Hauser sensors
- B. Rosemount 8732 transmitter
- C. Coils
- D. Electrodes

**Note**

Refer to [Figure E-1](#) for actual terminal block configuration drawing.

**Table E-6: Endress and Hauser Sensor Wiring Connections**

Rosemount 8732	Endress and Hauser sensors
1	41
2	42
3	14
17	4
18	5
19	7

## E.8 Fischer and Porter sensors

### E.8.1 Model 10D1418 sensor to 8732 Transmitter

To connect a Model 10D1418 sensor to a Rosemount 8732 Transmitter, connect coil drive and electrode cables as shown in [Figure E-7](#).

**⚠ CAUTION**

Do not connect mains or line power to the magnetic flowtube sensor or to the transmitter coil excitation circuit.

**Figure E-7: Wiring Diagram for Fischer and Porter Sensor Model 10D1418 and Rosemount 8732**

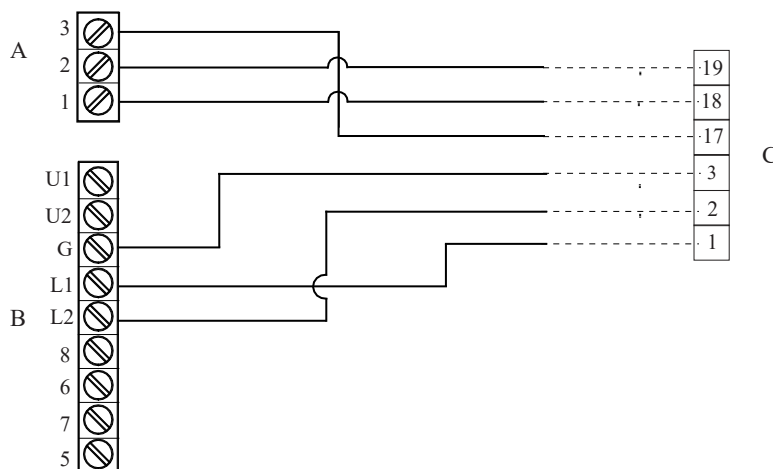

- A. Electrode connections
- B. Coil connections
- C. Rosemount 8732 transmitter

**Note**

Refer to [Figure E-1](#) for actual terminal block configuration drawing.

**Table E-7: Fischer and Porter Model 10D1418 Sensor Wiring Connections**

Rosemount 8732	Fischer and Porter Model 10D1418 sensors
1	L1
2	L2
3	Chassis ground
17	3
18	1
19	2

## E.8.2

### Model 10D1419 sensor to 8732 Transmitter

To connect a Model 10D1419 sensor to a Rosemount 8732 Transmitter, connect coil drive and electrode cables as shown in [Figure E-8](#).

**⚠ CAUTION**

Do not connect mains or line power to the magnetic flowtube sensor or to the transmitter coil excitation circuit.

**Figure E-8: Wiring Diagram for Fischer and Porter Sensor Model 10D1419 and Rosemount 8732**

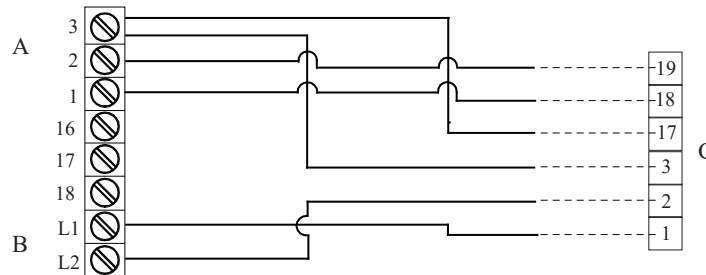

- A. Electrode connections
- B. Coil connections
- C. Rosemount 8732 transmitter

**Note**

Refer to [Figure E-1](#) for actual terminal block configuration drawing.

**Table E-8: Fischer and Porter Model 10D1419 Sensor Wiring Connections**

Rosemount 8732	Fischer and Porter Model 10D1419 sensors
1	L1
2	L2
3	3
17	3
18	1
19	2

### E.8.3 Model 10D1430 sensor (remote) to 8732 Transmitter

To connect a Model 10D1430 sensor (remote) to a Rosemount 8732 Transmitter, connect coil drive and electrode cables as shown in [Figure E-9](#).

**⚠ CAUTION**

Do not connect mains or line power to the magnetic flowtube sensor or to the transmitter coil excitation circuit.

**Figure E-9: Wiring Diagram for Fischer and Porter Sensor Model 10D1430 (Remote) and Rosemount 8732**

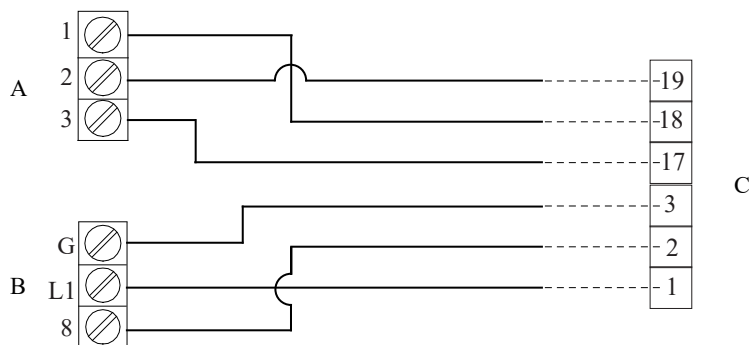

- A. Electrode connections
- B. Coil connections
- C. Rosemount 8732 transmitter

**Note**

Refer to [Figure E-1](#) for actual terminal block configuration drawing.

**Table E-9: Fischer and Porter Model 10D1430 (Remote) Sensor Wiring Connections**

Rosemount 8732	Fischer and Porter Model 10D1430 (Remote) sensors
1	L1
2	8
3	G
17	3
18	1
19	2

### E.8.4 Model 10D1430 sensor (integral) to 8732 Transmitter

To connect a Model 10D1430 sensor (integral) to a Rosemount 8732 Transmitter, connect coil drive and electrode cables as shown in [Figure E-10](#).

**⚠ CAUTION**

Do not connect mains or line power to the magnetic flowtube sensor or to the transmitter coil excitation circuit.

**Figure E-10: Wiring Diagram for Fischer and Porter Sensor Model 10D1430 (Integral) and Rosemount 8732**

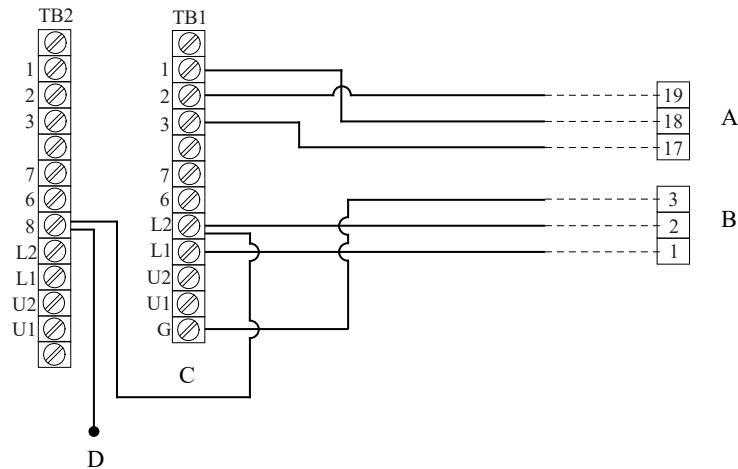

- A. Electrode connections
- B. Coil connections
- C. Blue
- D. To calibration device

**Note**

Refer to [Figure E-1](#) for actual terminal block configuration drawing.

**Table E-10: Fischer and Porter Model 10D1430 (integral) Sensor Wiring Connections**

Rosemount 8732	Fischer and Porter Model 10D1430 (Integral) sensors
1	L1
2	L2
3	G
17	3
18	1
19	2

### E.8.5 Model 10D1465/10D1475 sensors to 8732 Transmitter

To connect a Model 10D1465 or 10D1475 sensor (integral) to a Rosemount 8732 Transmitter, connect coil drive and electrode cables as shown in [Figure E-11](#).

**⚠ CAUTION**

Do not connect mains or line power to the magnetic flowtube sensor or to the transmitter coil excitation circuit.

**Figure E-11: Wiring Diagram for Fischer and Porter Sensor Model 10D1465 and Model 10D1475 (integral) and Rosemount 8732**

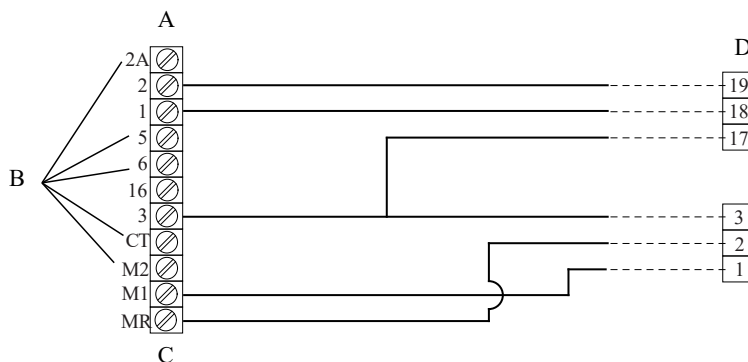

- A. Electrode connections
- B. Disconnect
- C. Coil connections
- D. Rosemount 8732 transmitter

**Note**

Refer to [Figure E-1](#) for actual terminal block configuration drawing.

**Table E-11: Fischer and Porter Model 10D1465 and 10D1475 Sensor Wiring Connections**

Rosemount 8732	Fischer and Porter Model 10D1465 and 10D1475 sensors
1	M1
2	MR
3	3
17	3
18	1
19	2

### E.8.6 Fischer and Porter sensor to 8732 Transmitter

To connect a Fischer and Porter sensor to a Rosemount 8732 Transmitter, connect coil drive and electrode cables as shown in [Figure E-12](#).

**⚠ CAUTION**

Do not connect mains or line power to the magnetic flowtube sensor or to the transmitter coil excitation circuit.

**Figure E-12: Generic Wiring Diagram for Fischer and Porter Sensors and Rosemount 8732**

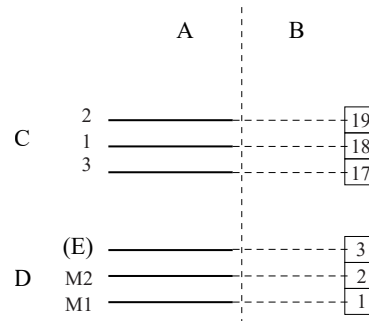

- A. Fischer and Porter sensors
- B. Rosemount 8732 transmitter
- C. Electrode connections
- D. Coil connections
- E. Chassis

**Note**

Refer to [Figure E-1](#) for actual terminal block configuration drawing.

**Table E-12: Fischer and Porter Generic Sensor Wiring Connections**

Rosemount 8732	Fischer and Porter sensors
1	M1
2	M2
3	Chassis ground
17	3
18	1
19	2

## E.9 Foxboro sensors

### E.9.1 Series 1800 sensor to 8732 Transmitter

To connect a Series 1800 sensor to a Rosemount 8732 Transmitter, connect coil drive and electrode cables as shown in [Figure E-13](#).

**⚠ CAUTION**

Do not connect mains or line power to the magnetic flowtube sensor or to the transmitter coil excitation circuit.



**Figure E-13: Wiring Diagram for Foxboro Series 1800 and Rosemount 8732**

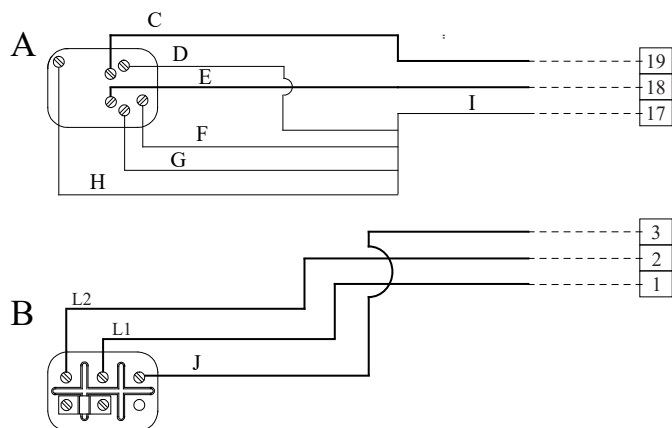

- A. Electrode connections
- B. Coil connections
- C. White lead
- D. White shield
- E. Black lead
- F. Inner shield
- G. Black shield
- H. Outer shield
- I. Any shield
- J. Chassis ground

**Note**

Refer to [Figure E-1](#) for actual terminal block configuration drawing.

**Table E-13: Foxboro Series1800 Sensor Wiring Connections**

Rosemount 8732	Foxboro Series 1800 sensors
1	L1
2	L2
3	Chassis ground
17	Any shield
18	Black
19	White

## E.9.2 Series 1800 (version 2) sensor to 8732 Transmitter

To connect a Series 1800 (version 2) sensor to a Rosemount 8732 Transmitter, connect coil drive and electrode cables as shown in [Figure E-14](#).

**⚠ CAUTION**

Do not connect mains or line power to the magnetic flowtube sensor or to the transmitter coil excitation circuit.

**Figure E-14: Wiring Diagram for Foxboro Series 1800 (Version 2) and Rosemount 8732**

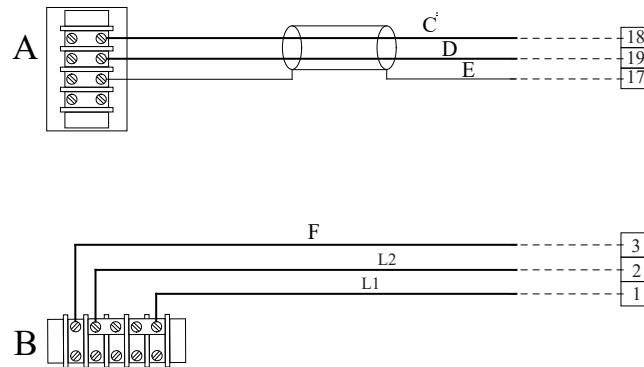

- A. Electrode connections
- B. Coil connections
- C. Black lead
- D. White lead
- E. Shield
- F. Chassis ground

**Note**

Refer to [Figure E-1](#) for actual terminal block configuration drawing.

**Table E-14: Foxboro Series 1800 (Version 2) Sensor Wiring Connections**

Rosemount 8732	Foxboro Series 1800 sensors
1	L1
2	L2
3	Chassis Ground
17	Any Shield
18	Black
19	White

### E.9.3 Series 2800 Sensor to 8732 Transmitter

To connect a Series 2800 Sensor to a Rosemount 8732 Transmitter, connect coil drive and electrode cables as shown in [Figure E-15](#).

**⚠ CAUTION**

Do not connect mains or line power to the magnetic flowtube sensor or to the transmitter coil excitation circuit.

**Figure E-15: Wiring Diagram for Foxboro Series 2800 and Rosemount 8732**

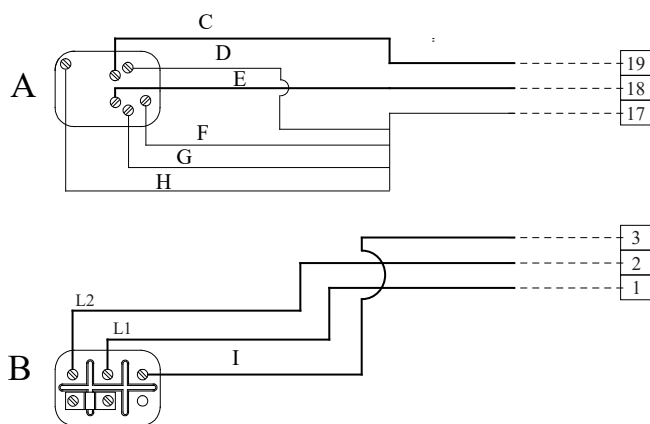

- A. Electrode connections
- B. Coil connections
- C. White lead
- D. Black lead
- E. Inner shield
- F. Black shield
- G. Outer shield
- H. Chassis ground

**Note**

Refer to [Figure E-1](#) for actual terminal block configuration drawing.

**Table E-15: Foxboro Series 2800 Sensor Wiring Connections**

Rosemount 8732	Foxboro Series 2800 Sensors
1	L1
2	L2
3	Chassis Ground
17	Any Shield
18	Black
19	White

## E.9.4 Foxboro Sensor to 8732 Transmitter

To connect a Foxboro Sensor to a Rosemount 8732 Transmitter, connect coil drive and electrode cables as shown in [Figure E-16](#).

**⚠ CAUTION**

Do not connect mains or line power to the magnetic flowtube sensor or to the transmitter coil excitation circuit.

**Figure E-16: Generic Wiring Diagram for Foxboro Sensors and Rosemount 8732**

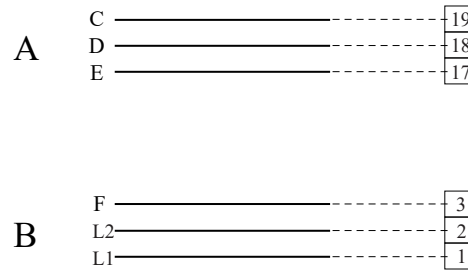

- A. Electrode connections
- B. Coil connections
- C. White
- D. Black
- E. Any shield
- F. Chassis ground

**Note**

Refer to [Figure E-1](#) for actual terminal block configuration drawing.

**Table E-16: Foxboro Generic Sensor Wiring Connections**

Rosemount 8732	Foxboro sensors
1	L1
2	L2
3	Chassis Ground
17	Any Shield
18	Black
19	White

## E.10 Kent Veriflux VTC sensor

### E.10.1 Veriflux VTC sensor to 8732 Transmitter

To connect a Veriflux VTC sensor to a Rosemount 8732 Transmitter, connect coil drive and electrode cables as shown in [Figure E-17](#).

**⚠ CAUTION**

Do not connect mains or line power to the magnetic flowtube sensor or to the transmitter coil excitation circuit.

**Figure E-17: Wiring Diagram for Kent Veriflux VTC Sensor and Rosemount 8732**

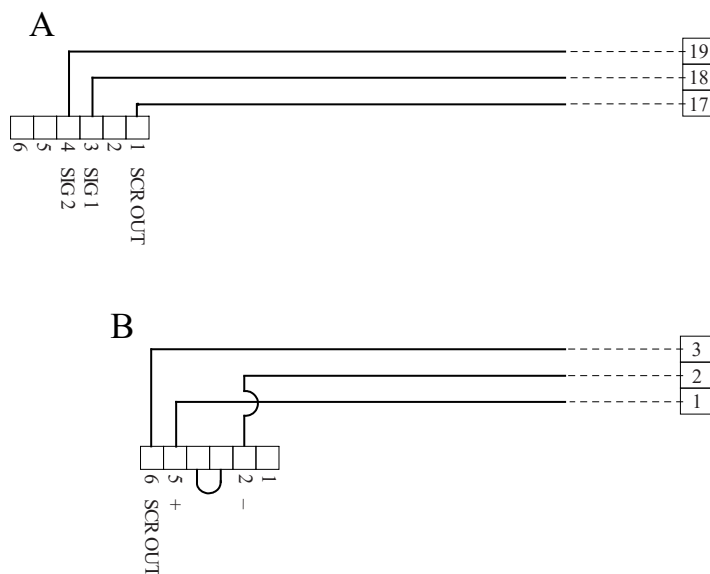

- A. Electrode connections
- B. Coil connections

**Note**

Refer to [Figure E-1](#) for actual terminal block configuration drawing.

**Table E-17: Kent Veriflux VTC Sensor Wiring Connections**

Rosemount 8732	Kent Veriflux VTC sensors
1	2
2	1
3	SCR OUT
17	SCR OUT
18	SIG1
19	SIG2

## E.11 Kent sensors

### E.11.1 Kent sensor to 8732 Transmitter

To connect a Kent sensor to a Rosemount 8732 Transmitter, connect coil drive and electrode cables as shown in [Figure E-18](#).

**⚠ CAUTION**

Do not connect mains or line power to the magnetic flowtube sensor or to the transmitter coil excitation circuit.

**Figure E-18: Generic Wiring Diagram for Kent Sensors and Rosemount 8732**

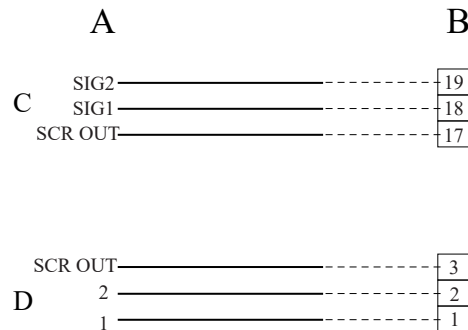

- A. Kent sensors
- B. Rosemount 8732 transmitter
- C. Electrode connections
- D. Coil connections

**Note**

Refer to [Figure E-1](#) for actual terminal block configuration drawing.

**Table E-18: Kent Sensor Wiring Connections**

Rosemount 8732	Kent sensors
1	1
2	2
3	SCR OUT
17	SCR OUT
18	SIG1
19	SIG2

## E.12 Krohne sensors

### E.12.1 Krohne sensor to 8732 Transmitter

To connect a Krohne sensor to a Rosemount 8732 Transmitter, connect coil drive and electrode cables as shown in [Figure E-19](#).

**⚠ CAUTION**

Do not connect mains or line power to the magnetic flowtube sensor or to the transmitter coil excitation circuit.

**Figure E-19: Generic Wiring Diagram for Krohne Sensors and Rosemount 8732**

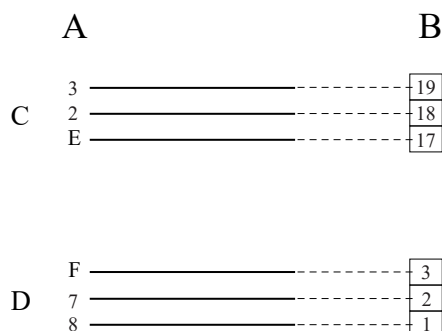

- A. Kent sensors
- B. Rosemount 8732 transmitter
- C. Electrode connections
- D. Coil connections
- E. Electrode shield
- F. Coil shield

**Note**

Refer to [Figure E-1](#) for actual terminal block configuration drawing.

**Table E-19: Krohne Sensor Wiring Connections**

Rosemount 8732	Krohne sensors
1	8
2	7
3	Coil Shield
17	Electrode Shield
18	2
19	3

## E.13 Taylor sensors

### E.13.1 Series 1100 sensor to 8732 Transmitter

To connect a Series 1100 sensor to a Rosemount 8732 Transmitter, connect coil drive and electrode cables as shown in [Figure E-20](#).

**⚠ CAUTION**

Do not connect mains or line power to the magnetic flowtube sensor or to the transmitter coil excitation circuit.

Figure E-20: Wiring Diagram for Taylor Series 1100 Sensors and Rosemount 8732



- A. Taylor Series 1100 sensor
- B. Rosemount 8732 transmitter
- C. Coil connections
- D. Electrode connections
- E. White
- F. Black
- G. Green

**Note**

Refer to [Figure E-1](#) for actual terminal block configuration drawing.

Table E-20: Taylor Series 1100 Sensor Wiring Connections

Rosemount 8732	Taylor Series 1100 sensors
1	Black
2	White
3	Green
17	S1 and S2
18	E1
19	E2

### E.13.2 Taylor sensor to 8732 Transmitter

To connect a Taylor sensor to a Rosemount 8732 Transmitter, connect coil drive and electrode cables as shown in [Figure E-21](#).

**⚠ CAUTION**

Do not connect mains or line power to the magnetic flowtube sensor or to the transmitter coil excitation circuit.



**Figure E-21: Generic Wiring Diagram for Taylor Sensors and Rosemount 8732**

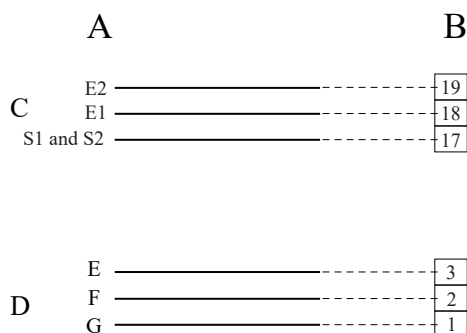

- A. Taylor sensor
- B. Rosemount 8732 transmitter
- C. Electrode connections
- D. Coil connections
- E. Green
- F. White
- G. Black

**Note**

Refer to [Figure E-1](#) for actual terminal block configuration drawing.

**Table E-21: Taylor Sensor Wiring Connections**

Rosemount 8732	Taylor sensors
1	Black
2	White
3	Green
17	S1 and S2
18	E1
19	E2

## E.14 Yamatake Honeywell sensors

### E.14.1 Yamatake Honeywell sensor to 8732 Transmitter

To connect a Yamatake Honeywell sensor to a Rosemount 8732 Transmitter, connect coil drive and electrode cables as shown in [Figure E-22](#).

**⚠ CAUTION**

Do not connect mains or line power to the magnetic flowtube sensor or to the transmitter coil excitation circuit.

**Figure E-22: Generic Wiring Diagram for Yamatake Honeywell Sensors and Rosemount 8732**

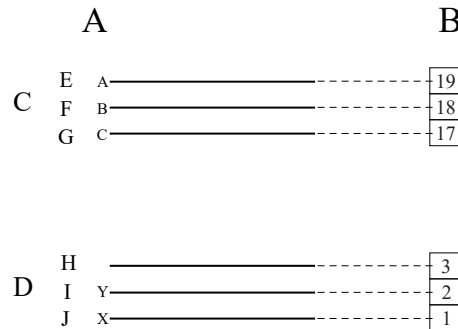

- A. Yamatake Honeywell sensors
- B. Rosemount 8732 transmitter
- C. Electrode connections
- D. Coil connections
- E. Terminal A
- F. Terminal B
- G. Terminal C
- H. Chassis ground
- I. Terminal Y
- J. Terminal X

**Note**

Refer to [Figure E-1](#) for actual terminal block configuration drawing.

**Table E-22: Yamatake Honeywell Sensor Wiring Connections**

Rosemount 8732	Yamatake Honeywell sensors
1	X
2	Y
3	Chassis Ground
17	C
18	B
19	A

## E.15 Yokogawa sensors

### E.15.1 Yokogawa sensor to 8732 Transmitter

To connect a Yokogawa sensor to a Rosemount 8732 Transmitter, connect coil drive and electrode cables as shown in [Figure E-23](#).

**⚠ CAUTION**

Do not connect mains or line power to the magnetic flowtube sensor or to the transmitter coil excitation circuit.

**Figure E-23: Generic Wiring Diagram for Yokogawa Sensors and Rosemount 8732**

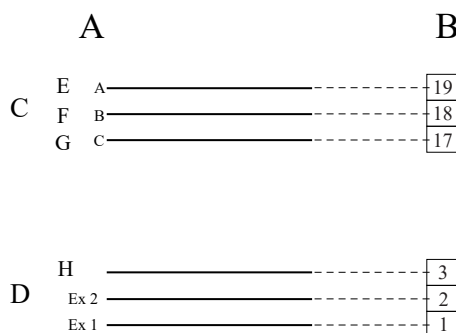

- A. Yokogawa sensors
- B. Rosemount 8732 transmitter
- C. Electrode connections
- D. Terminal A
- E. Terminal B
- F. Terminal C
- G. Chassis ground

**Note**

Refer to [Figure E-1](#) for actual terminal block configuration drawing.

**Table E-23: Yokogawa Sensor Wiring Connections**

Rosemount 8732	Yokogawa sensors
1	EX1
2	EX2
3	Chassis Ground
17	C
18	B
19	A

## E.16 Generic manufacturer sensor to 8732 Transmitter

### E.16.1 Identify the terminals

**Prerequisites**

Check first the sensor manufacturer’s manual to identify the appropriate terminals. Otherwise, perform the following procedure.

## Identify coil and electrode terminals

### Procedure

1. Select a terminal and touch an ohmmeter probe to it.
2. Touch the second probe to each of the other terminals and record the results for each terminal.
3. Repeat the process and record the results for every terminal.

Coil terminals will have a resistance of approximately 3-300 ohms.

Electrode terminals will have an open circuit.

## Identify a chassis ground

### Procedure

1. Touch one probe of an ohmmeter to the sensor chassis.
2. Touch the other probe to the each sensor terminal and the record the results for each terminal.

The chassis ground will have a resistance value of one ohm or less.

## E.16.2 Wiring connections

### Procedure

#### **⚠ CAUTION**

Do not connect mains or line power to the magnetic flowtube sensor or to the transmitter coil excitation circuit.

1. Connect the electrode terminals to Rosemount 8732 terminals 18 and 19. The electrode shield should be connected to terminal 17.
2. Connect the coil terminals to Rosemount 8732 terminals 1, 2, and 3.
3. If the Rosemount 8732 Transmitter indicates a reverse flow condition, switch the coil wires connected to terminals 1 and 2.



For more information: [Emerson.com/global](https://emerson.com/global)

©2024 Emerson. All rights reserved.

Emerson Terms and Conditions of Sale are available upon request. The Emerson logo is a trademark and service mark of Emerson Electric Co. Rosemount is a mark of one of the Emerson family of companies. All other marks are the property of their respective owners.

**ROSEMOUNT™**

