

AVENTICS™

ZONED SAFETY MANIFOLDS **501 - 502 - 503**

Technical Manual **Machine Safety EN/ISO 13849**



* Evaluated by TÜV Rheinland (Report No. 968/FSP 1228.00/16 - 503) & (Report No. 968/V 1045.00/18 - 501/502) in accordance with ISO 13849-1 and ISO 13849-2.

Conditions for use of this product

- (1) AVENTICS Manifold ("the PRODUCT") shall be used in conditions;
- i) Where any problem, fault or failure occurring in the PRODUCT, if any, shall not lead to any major or serious accident.

 - ii) Where the backup and fail-safe function are systematically or automatically provided outside of the PRODUCT for the case of any problem, fault or failure occurring in the PRODUCT.
- (2) The PRODUCT has been designed and manufactured for the purpose of being used in general industries.

ASCO L.P. shall have no responsibility or liability including but not limited to any and all responsibility or liability based on contract, warranty, tort, product liability for any injury or death to persons, loss or damage to property caused by the product that are operated or used in application not intended or excluded by instructions, precautions or warnings contained in AVENTICS Technical, User, Instruction, Safety Manuals, I&M Sheets or Bulletins.

Precautions

Before using this product, please read this manual and the relevant manuals in their entirety, carefully and pay attention to safety and product application. The following symbols are used in the manual to identify important safety, installation and application information.



CAUTION

CAUTION symbol indicates a possible hazard which may cause injury or equipment damage.



NOTE symbol indicates information useful to the user.



ATTENTION

ATTENTION symbol indicates important information regarding installation and setup.



CAUTION

Electrical installation and operational guidelines

- **All AVENTICS communication nodes should be grounded during the installation process. These grounding guidelines can be found in National Electrical code IEC 60204-1 or EN 60204-1.**
- **All AVENTICS G3 Electronics Products to be installed or wired in accordance with AVENTICS published instructions and applicable electrical codes. The following shall apply per UL, if required.**
- **To be connected to a Class 2 power source only.**
- **Class 2 Device Wiring Only – Do Not Reclassify and Install as Class1, 3 or Power and Lighting Wiring.**
- **Wire connection shall be rated suitable for the wire size (lead and building wiring) employed.**
- **SYSTEM MAXIMUM MODULES: Up to a maximum 16 I/O modules (units) can be connected to 1 Communication Module not including any Sub-Bus and Miscellaneous modules, or equivalent.**
- **CLASS 2 WIRING: All field wiring shall be suitable for Class 1, Electric Light and Power, or Class 2, 3 wirings are routed separately and secured to maintain separation between**
 - 1) **Class 2 wiring and all other class wiring, and**
 - 2) **Limited energy circuit conductors from unlimited energy circuit conductors.**
- **MULTIPLE CLASS 2 POWER SOURCES: When interconnected, class 2 sources shall be Listed and rated suitable for parallel interconnection.**
- **When using molded connector power cables, Do Not rely on wire colors for Pin-Out. Always use pin number references.**

Safety Information

The Zoned Safety Manifold (501, 502 & 503) have been evaluated by TÜV Rheinland ® (Report No. 968/FSP 1228.00/16 – 503 and Report No. 986/V 1045.00/18 – 501/502 to satisfy the requirements of ISO 13849-1 Type-B for use in pneumatic safety related applications. The Zoned Safety Manifold is part of a Safety System as a Safety Related Part (SRP) and can be used in Safety Systems up to Category 3 PLd; with appropriate external safety control functionality (e.g. monitoring, timing, pulse test, etc.) and insuring that adherence to all related Safety Standards are met. Per ISO 13849, the end user or third-party organization must evaluate and certify adherence of the complete Control System (CS) including all SRPs. Reliability data of our pneumatic components can be given upon request. More details on sample applications and technical information can be found in our technical manual available on our website.

In accordance with ISO 13849-2 specifications, both safe and standard components must be powered using an SELV/PELV DC power supplies.

In order to ensure that cross talk of internal 0 VDC & 24 VDC channels is not possible, each external supply line (0 VDC & 24 VDC) to the component must be interrupted using a dual channel safety relay or dual channel safety output device.

When used in certain environments that can have conductive dust, water or other media that can cause internal conduction, an appropriate cabinet or enclosure shall be used.

When valves with Manual overrides are selected for the U-Wiring and X-Wiring manifold blocks, adequate measures must be taken to prevent any hazardous situations that may occur (e.g. use the diagnostic feedback of the DC elements as identification on a display).

Machinery Directive and Related Standards:

Machinery Directive (MD) 2006/42/EC

ISO 13849-1

ISO 13849-2

IEC 62061

EN ISO 12100-1

ISO 4414

Table of Contents

	<u>PAGE</u>
1. Zoned Safety Manifold Introduction	1-6
1.1 Overview	1-6
1.2 ZONED SAFETY Manifold Features.....	1-6
2. Zoned Safety Manifold (SRP/CS).....	2-7
2.1 Zoned Safety Manifolds.....	2-7
2.2 Zoned Safety - Zoned Power Manifold Base ("X" Wiring).....	2-8
2.3 Zoned Safety - Pilot Valve Manifold Base ("U" Wiring).....	2-8
2.4 Zoned Safety - Auxiliary Port 4 Sandwich Block.....	2-9
2.5 Zoned Safety - Pilot Separation Sandwich Block	2-9
2.6 Pilot Separation - Zoned and Individual	2-10
2.7 Zoned Safety Control System Connection Diagram	2-11
3. G3 Protocol Support / Configuration.....	3-12
3.1 Protocol Support.....	3-12
3.2 Zoning Safety Configuration - Display	3-13
3.3 Zoned Safety Configuration - Web Server	3-14
4. Zoned Safety Manifold Mapping	4-16
4.1 Zoned Safety Manifold Mapping	4-16
4.2 Zoned Safety Manifold Data Sizing Worksheet (EtherNet/IP DLR Example)	4-17
4.3 Zoned Safety Mapping Example #1 (EtherNet/IP DLR Node - 503).....	4-18
4.4 Zoned Safety Mapping Example #2 (EtherNet/IP DLR Node - 503).....	4-20
4.5 Zoned Safety Mapping Example #3 (EtherNet/IP DLR Node - 501).....	4-22
5. Zoned Safety Web Server	5-24
5.1 Node Configuration.....	5-24
5.2 Diagnostics	5-25
6. Zoned Safety Circuit Examples/Analysis	6-27
6.1 Example #1 Automated Assembly Machine.....	6-27
6.2 Example #2 Automated Insertion Tool	6-32
6.3 Example #3 Clamping Weld Fixture	6-37
7. Appendix.....	7-42
7.1 System Specifications	7-42
7.2 Factory Default Settings	7-42
7.3 Troubleshooting/Error Messaging	7-42
7.4 Glossary of Terms.....	7-43
7.5 Technical Support	7-43

1. Zoned Safety Manifold Introduction

1.1 Overview

The Zoned Safety Manifold is intended to be used in pneumatic circuits to provide functional safety in accordance with the Machinery Directive 2006/42/CE and the ISO 13849 standards. This unit is an integrated assembly that incorporates the required Output Devices (SRP/CS), necessary to satisfy up to Category 3 of ISO 13849-1; see Category 3 architecture, below from ISO 13849-1. The Zoned Safety Manifold must be connected to the G3 Platform of AVENTICS Fieldbus Electronics.

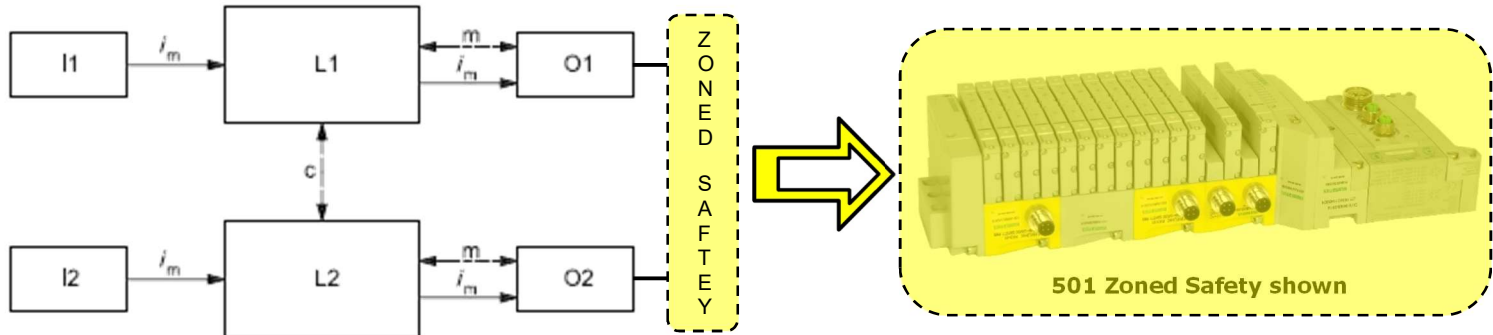

Unique components (in yellow) represent the Output Device in each channel identified above. The complete Zoned Safety Manifold integrates these required functions into an easy-to-render pneumatic system that allows for the required Safety adherence. See section 2 for further breakdown of the complete Zoned Safety Manifold. Complete adherence up to Category 3 requires implementation of the Input Device and Logic Element in addition to the Zoned Safety Manifold.

1.2 ZONED SAFETY Manifold Features

Features	Description
G3 Support	Functional with all ETHERNET based Fieldbus protocols (See Sec. 3.1)
Up to Category 3 PLd	Evaluated against ISO 13849-1 & 2, by TÜV Rheinland
Multiple Zones	One manifold supports up to 3 Safety Zones, up to 16 coils each
Integral Pilot Valve(s)	Pilot valve support integral to manifold, can be external if required
Standard Valve Support	Up to 32 coil capability, in one Standard area (in addition to Safety Zones)
Pilot Separation	Optional Pilot Separation of power valves

2. Zoned Safety Manifold (SRP/CS)

2.1 Zoned Safety Manifolds

The Zoned Safety Manifold incorporates the required pneumatic SRP/CS (Safety Related Parts of a Control System) into a single manifold assembly.

The following sub sections detail the various groupings and individual components that make up the Safety Manifold Zone(s). The manifold example below only represents two of the possible three zones.

For complete detail of the Zoned Safety Manifold assembly and I/O mapping; refer to Section 4 of this Technical Manual.

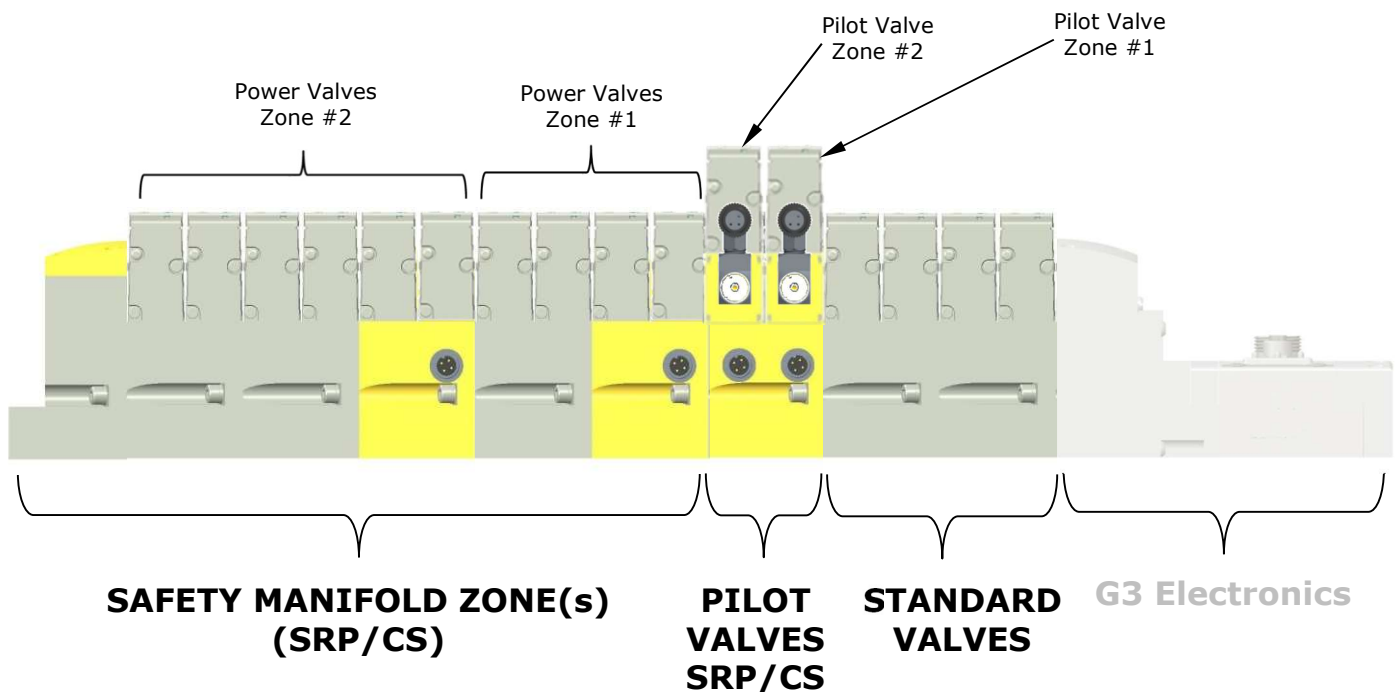

502 and 503 represented above, 501 similar in capability but without the support of the Port 4 Sandwich block or the Pilot Separation Block.

AVENTICS™ ZONED SAFETY MANIFOLD Technical Manual

2.2 Zoned Safety - Zoned Power Manifold Base ("X" Wiring)

The Zoned Power Manifold base with the M12 connector, supplies power to the integrated valve solenoid drivers and routes the output signals to any additional manifold base(s) connected within a zone. Up to (16) valve solenoid coils can be controlled in each zone. All connected valve solenoid coils are controlled from the attached G3 node. The M12 connector must be externally supplied from a Safety Relay or Safety Output via a Safety PLC. This becomes one of the redundant channels for a Category 3 application.

The valve(s) mounted on the Zoned Power Manifold Base and subsequent valve manifold bases, are referred to as "Power Valves". They drive the pneumatic actuators in a pneumatic safety circuit; providing one of the pneumatic channels of a Category 3 circuit.

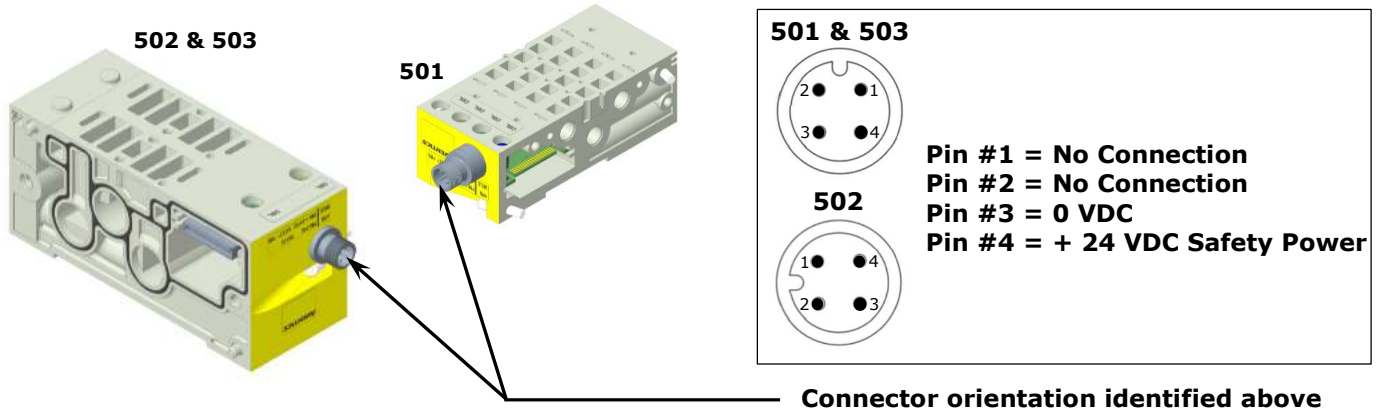

2.3 Zoned Safety - Pilot Valve Manifold Base ("U" Wiring)

The Pilot Valve Manifold Base controls the mounted pilot valves via the M12 connector, isolated from the connected G3 node. Supply air, Exhaust and Pilot air are common with the other manifold blocks. The M12 connector must be externally supplied by a Safety Relay or Safety Output via a Safety PLC. This becomes one of the redundant channels for a Category 3 application.

The valve(s) is used to supply Pilot Operated (PO) Check Valves, Rod-Locks, Pilot Operated Spring Return Valves, etc. The pilot valve(s) along with external pneumatic components provide one of the pneumatic channels of a Category 3 circuit.

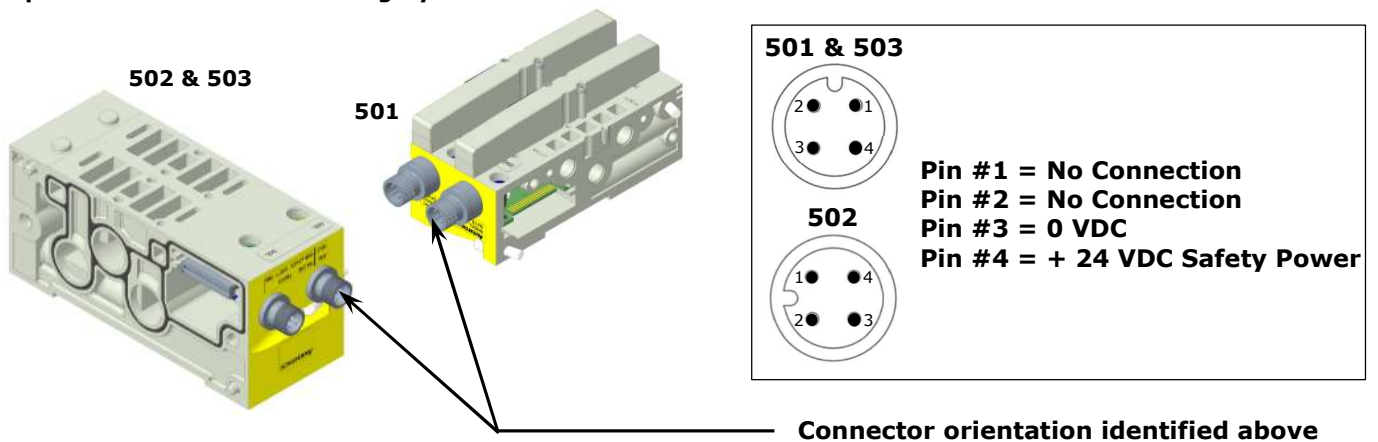

Test pulses from electronic safety output devices will cause the valve's solenoid LED connected to the "U" wiring manifold type to flicker at the same rate as the safety output pulse test and make it appear dimmer than the other solenoid LEDs. This is normal and will not harm any of the components including the solenoid valve. The "X" wiring manifold option does not exhibit this dimming effect as it contains dedicated zone drivers which help to reduce this effect.

AVENTICS™ ZONED SAFETY MANIFOLD Technical Manual

2.4 Zoned Safety – Auxiliary Port 4 Sandwich Block

The Auxiliary Port 4 Sandwich Block assembly mounts beneath the Pilot Valve(s), incorporating the AP10 pressure switch for indirect monitoring of the Pilot Valves, and providing Diagnostic Coverage. This block also allows for the routing of air from port 4 of the Pilot Valve Manifold Base, to supply pilot pressure to the Pilot Separation Sandwich Block (Zoned or Individual) of the manifold; see Sec 2.5 and 2.6. The Port 4 Sandwich assembly is available with or without pressure switch.

* Auxiliary Port 4 Sandwich Block, not available for 501 Zoned Safety Manifolds

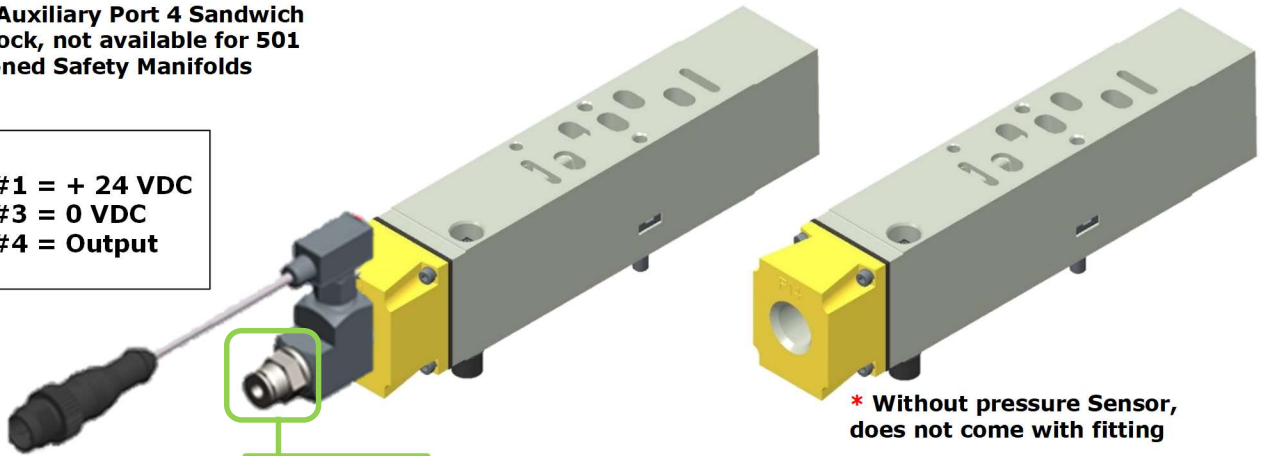
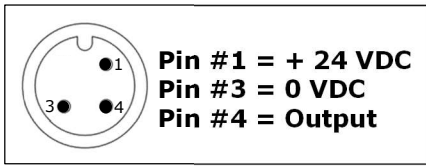

* Without pressure Sensor, does not come with fitting

INB10-532-020 - Fitting – 502/503
129-100 – 1/8 Plug – 502/503

IN438-020-000 1/8 – 502
IN438-021-001 1/4 – 503



Port is either equipped with a plug (WITHOUT pilot zoning) or with a Male Straight 5/32 (4mm) fitting (WITH pilot zoning).

The ports of the street T (WITH pressure switch) are NPT. For applications that require the removal of the fitting or plug, and BSPP/G ports, an adapter can be purchased, see catalog for details.

2.5 Zoned Safety – Pilot Separation Sandwich Block

A single Zoned Pilot Sandwich Block can be used in each zone to ensure complete disabling of pilot pressure to all power valves within a zone. This ensures that the power valves cannot shift (manually or electronically) unless pressure is supplied to this blocks supply port. Available with or without fitting. Individual Pilot Sandwich Blocks are available for individual piloting of valves, see Sec 2.6. The Pilot Separation Blocks are available with and without fittings.

* Pilot Separation Sandwich Block, not available for 501 Zoned Safety Manifolds

INB10-532-020
Fitting – 502/503

Optional Pilot Supply port from Auxiliary Port 4 Sandwich

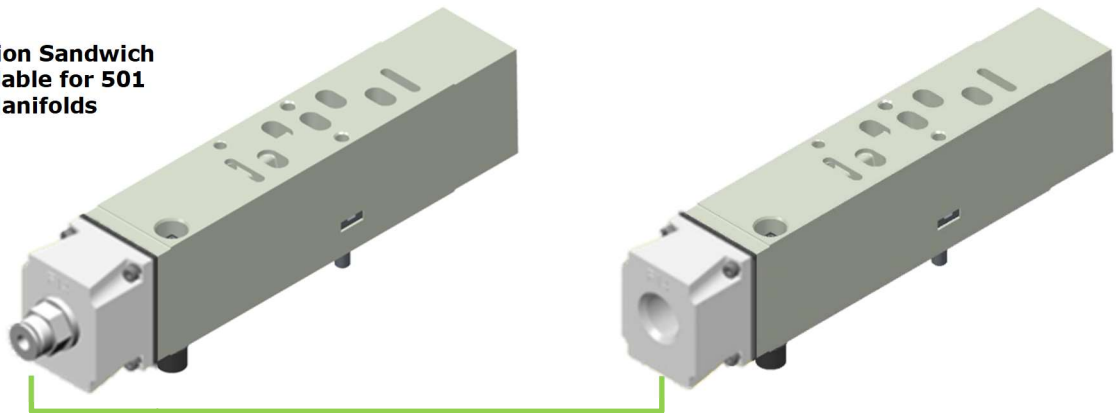

TDG3ZSTM1-5EN 08/20
Subject to change without notice

AVENTICS™ ZONED SAFETY MANIFOLD Technical Manual

2.6 Pilot Separation – Zoned and Independent

The option exists to provide pilot air to each zone or to individual valves in each zone, separate from the Internal or External pilot supply that is provided from the endplates. Below represent some of the different piloting options available.

Internally or Externally supplied from the Endplate(s)

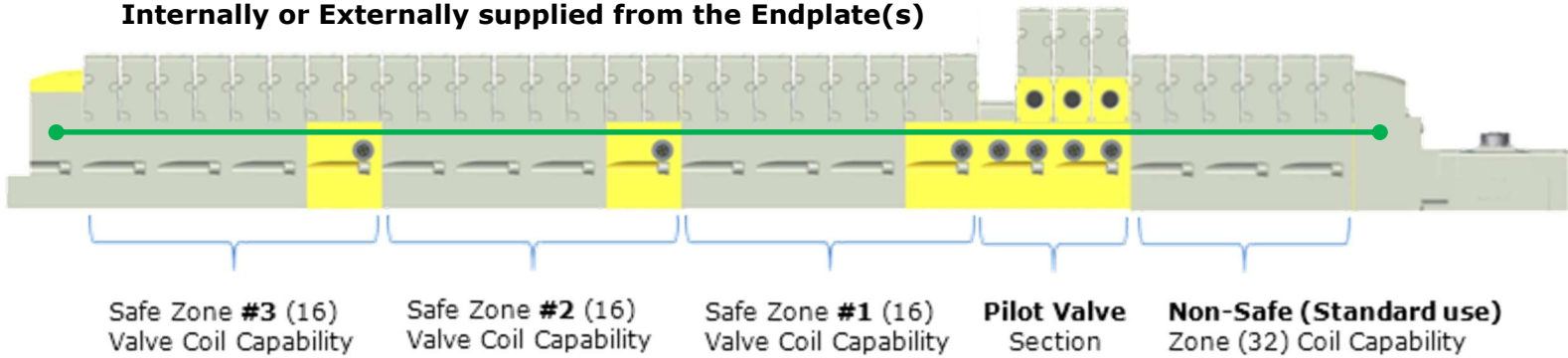

Supplied from Port 4 Sandwich to Zoned Pilot Sandwich

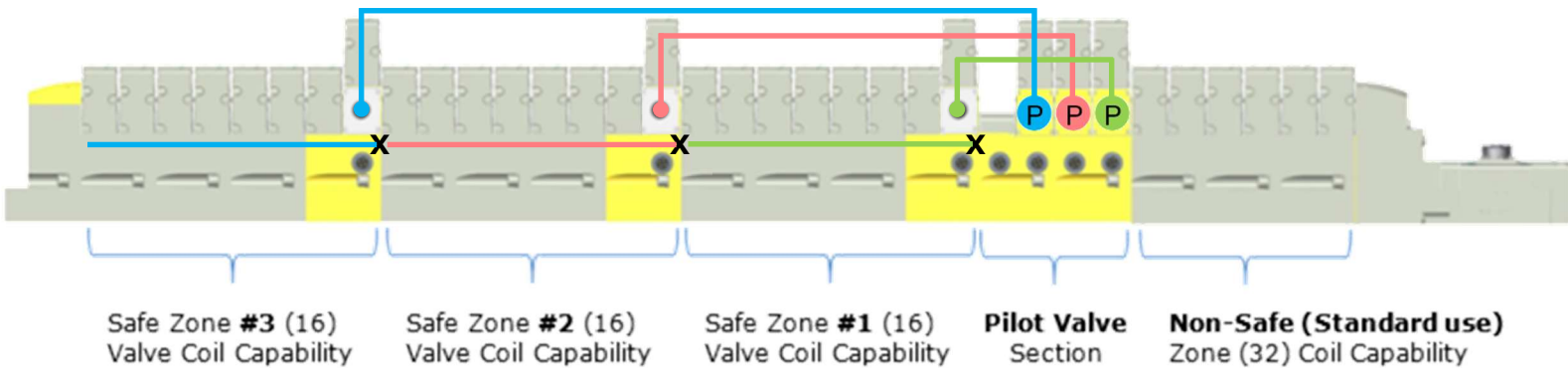

Supplied from Port 4 Sandwich to Individual Pilot Sandwich

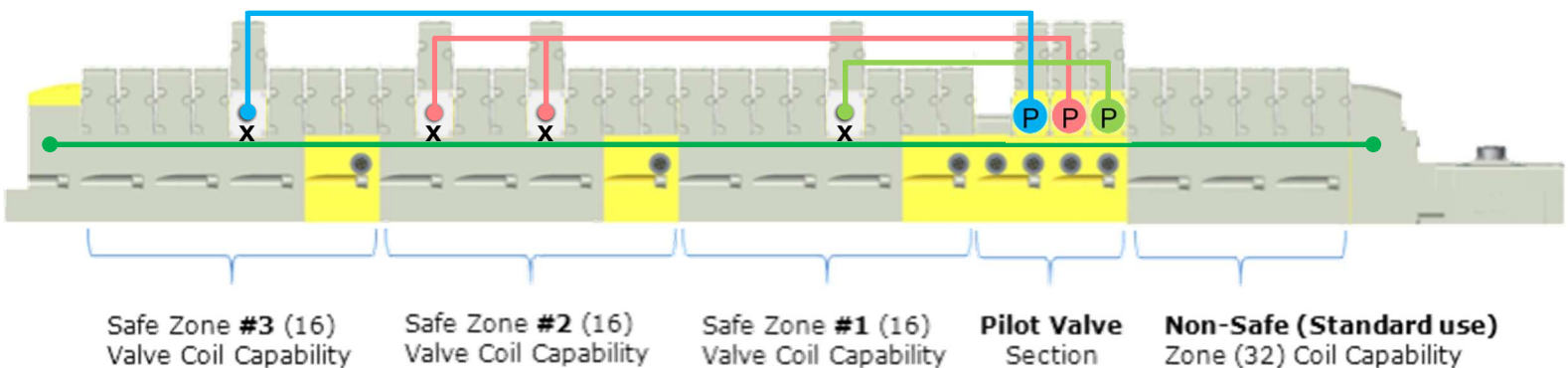

AVENTICS™ ZONED SAFETY MANIFOLD Technical Manual

2.7 Zoned Safety Control System Connection Diagram

This Diagram represents a typical application showing a Safety PLC, Remote Safety I/O Module and a two zone, Zoned Safety Manifold. This example represents one of many control platform suppliers that can be utilized with a Zoned Safety Manifold. The "X" and "U" manifold connections require a safety output with monitoring and diagnostics. Other safety output devices (e.g. Safety Output Relays, etc.) can also be used to provide the necessary safety output function to the "X" and "U" manifold bases.

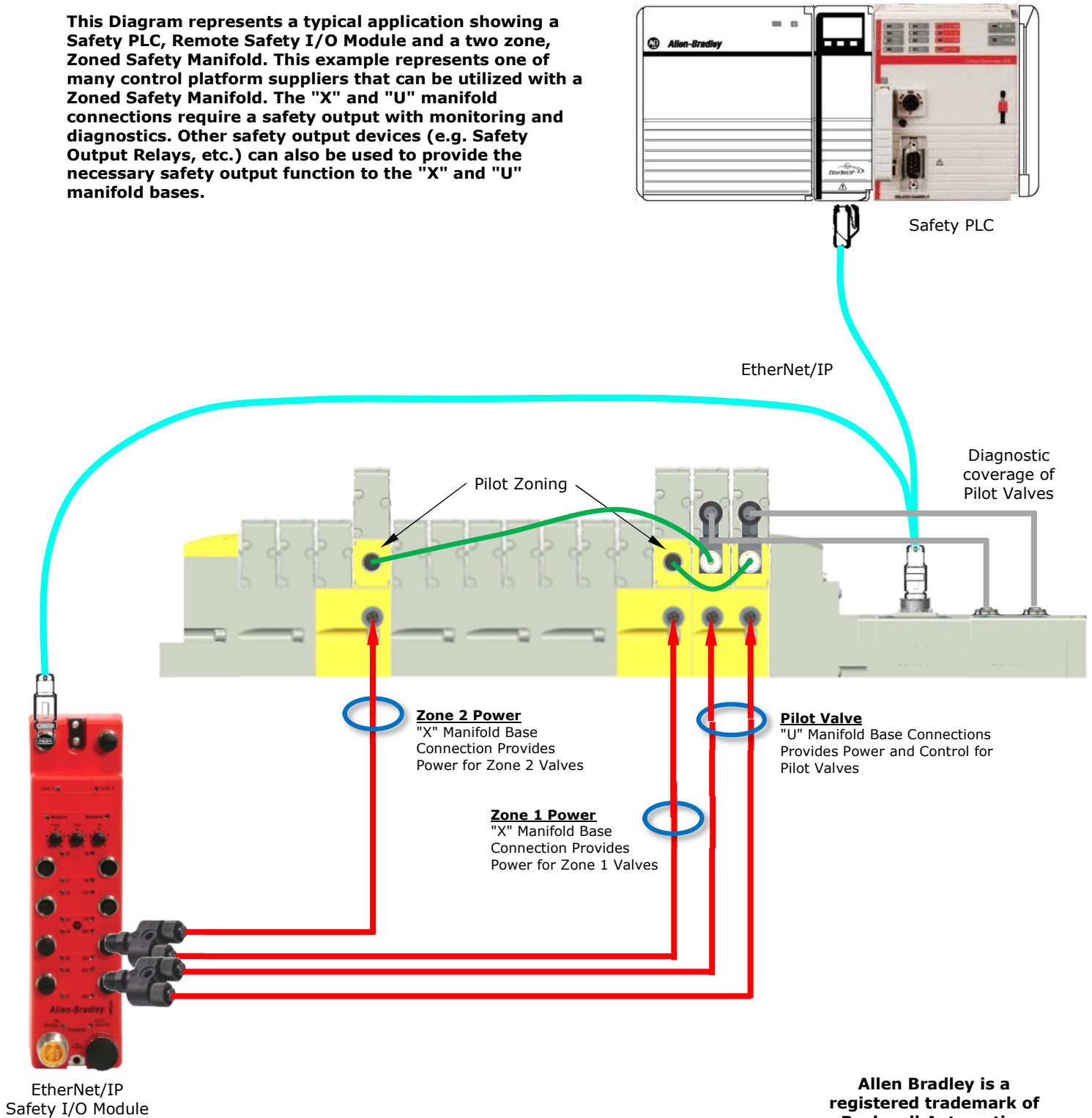

3. G3 Protocol Support / Configuration

3.1 Protocol Support

The Zoned Safety Manifolds must be connected to a G3 Electronics Node to operate. Not all G3 supported protocols will support the Zoned Safety Manifolds. Below is a list of the G3 protocols that support the Zoned Safety Manifolds.

Zoned Safety Manifold Protocol Compatibility				
Node Protocol	Node Part No.	Minimum Firmware Revision	Technical Manual No.	Minimum Valve Driver Firmware
EtherNet/IP	240-181	Rev. 1.01, Build 42389-2	TDG3 EN TM1-xEN	4.016
EtherNet/IP DLR	240-325	Rev. 1.01, Build 42389-2	TDG3 ED TM1-xEN	4.016
Modbus TCP	240-292	Rev. 1.01, Build 42389-2	TDG3 EM TM1-xEN	4.016
PROFINET	240-240	Rev. 1.01, Build 42389-2	TDG3 PN TM1-xEN	4.016
POWERLINK	240-309	Rev. 1.01, Build 42391	TDG3 PL TM1-xEN	4.016
EtherCAT	240-310	Rev. 1.01, Build 42389-2	TDG3 EC TM1-xEN	4.016

G3 Technical Manuals can be downloaded from <http://www.asco.com/en-us/Pages/fieldbus-technical-document-search.aspx>

The Zoned Safety Manifold can be configured to operate three separate and isolated zones. The manifold will need to be configured to operate the connected zones; unless already configured from the factory. Zone configuration for all protocols is the same. See section 3.2 and 3.3 for safety zone setting.

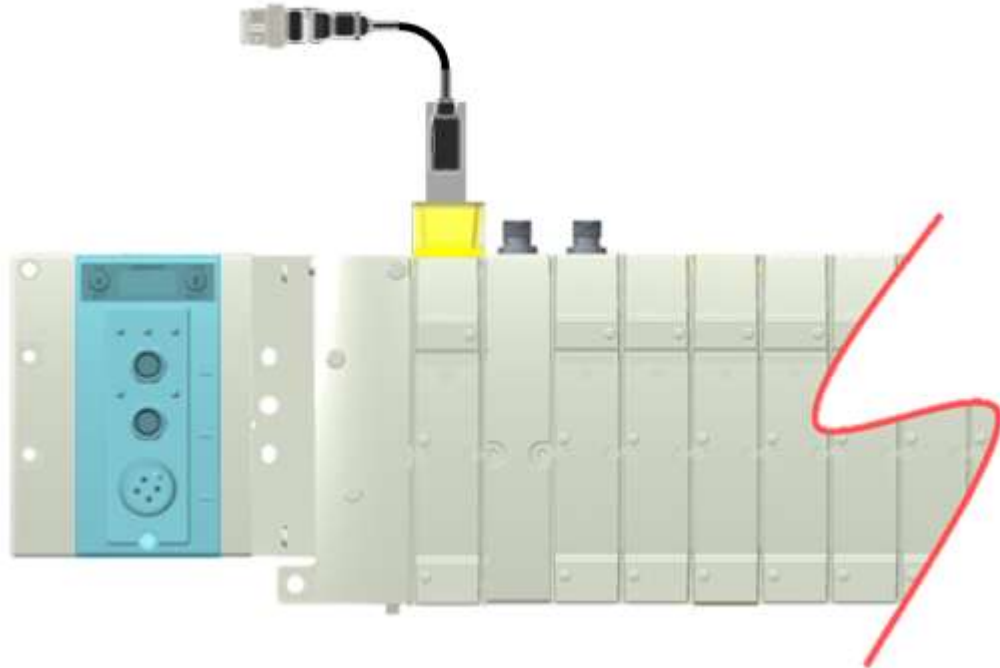

Nodes and Valve Driver assemblies with Firmware prior to the revisions listed are not compatible with Zoned Safety. All information related to the G3 platform of electronics and the specific protocol should be referenced in their respective Technical Manual. Each Technical Manual can be found at www.asco.com.

AVENTICS™ ZONED SAFETY MANIFOLD Technical Manual

3.2 Zoning Safety Configuration – Display

The Safety Zone parameter can be set using the nodes integrated display. The menu system below identifies the appropriate steps for setting the number of zones. This should match the number of safe zones in the physical configuration of the Zoned Safety Manifold. If the manifold was assembled and tested by ASCO, the correct number of zones will have already been configured prior to shipment.

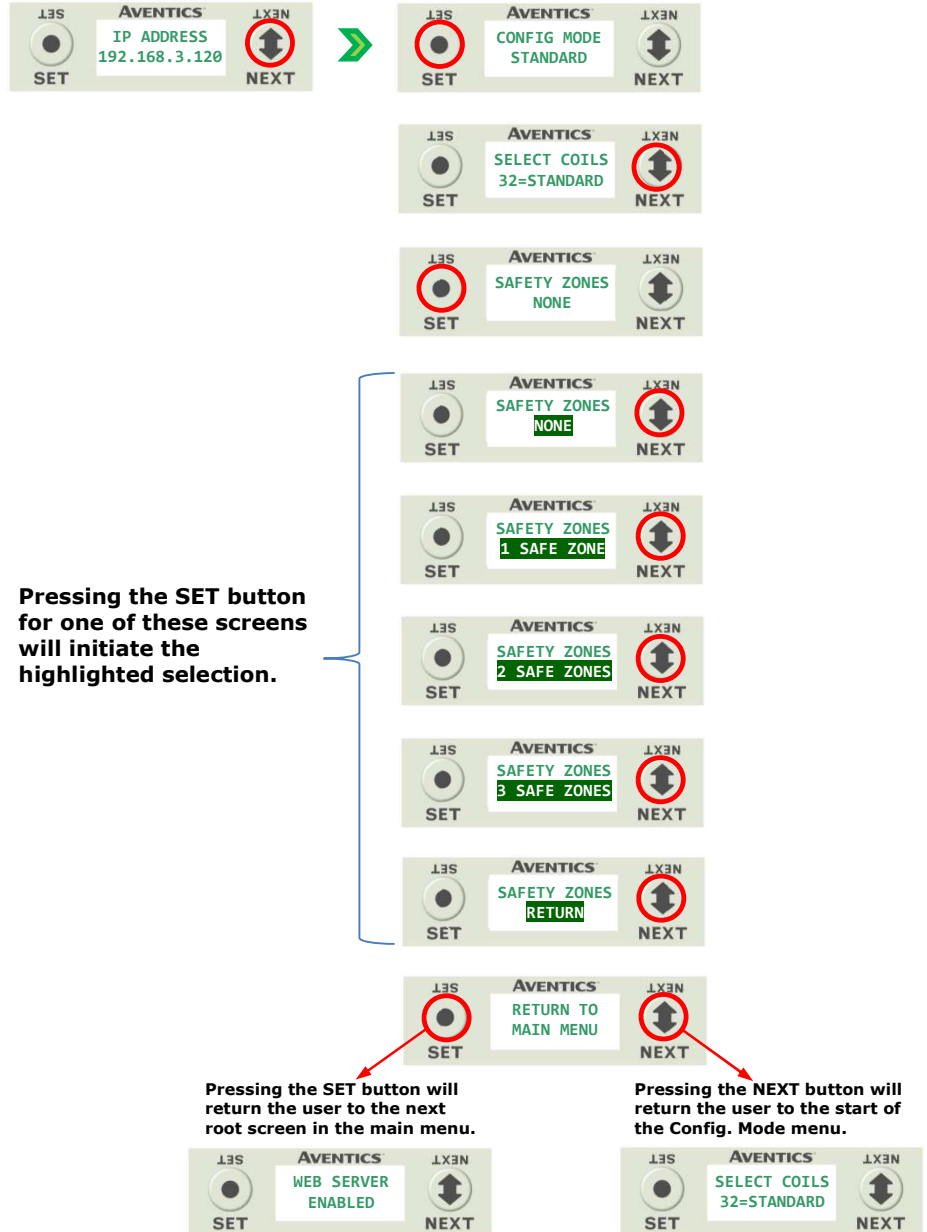

Insure Firmware Revision and Valve Driver Part No. are compatible with Zoned Safety Functionality; see Section 3.1.

AVENTICS™ ZONED SAFETY MANIFOLD Technical Manual

3.3 Zoned Safety Configuration – Web Server

Under the Node Configuration tab of the node's web server, there is the "Safety Zones" parameter. This parameter allows the user the ability to change the supported number of Safe Zones to match the physical configuration of the Zoned Safety Manifold. If the manifold was assembled and tested by ASCO, the correct number of zones will have already been configured if manifold assembly is shipped from the factory.

Number of Safety Zones should only be adjusted if an additional Zone(s) has been physically added. As identified above, the Safety Zone size should have already been selected prior to test and ship. This screen represents a replacement node with "Default" settings.

Node Configuration (Green selections denote Factory Default settings)	
DHCP:	Disabled
IP Address:	192.168.3.120
Subnet Mask:	255.255.255.0
Gateway IP Address:	
Web Server:	Enabled
Max Coils on Manifold (32 = Standard):	32
Safety Zones (Only configurable when Max Coils = 32):	None
COMM Fault / Idle Mode:	Turn OFF All Outputs
Numatics Part No. 240-181 Compatibility Mode:	Disabled
Diagnostic Word:	Mapped
I/O (Diagnostics) Status:	Mapped
Node Configuration Parameters:	Unlocked
I/O Configuration:	Unlocked
Quick Connect:	Disabled
Display Orientation (Global):	Normal
Display Brightness:	Medium
Comm. Format (I/O Data Padding):	SINT

Update Configuration



Web Page may vary slightly for each supported protocol. Refer to specific protocol's Technical Manual for detail on commissioning. See Section 3.1 of this manual for supported protocols.

AVENTICS™ ZONED SAFETY MANIFOLD Technical Manual

To adjust/set the appropriate number of zones, use the pull-down menu of the Safety Zones parameter. As shown below, a maximum of (3) zones are available. If the number of zones chosen does not match the physical configuration, error messaging will appear. Refer to section 7.3 for trouble shooting/error messaging descriptions and correction.

Node Configuration
(Green selections denote Factory Default settings)

DHCP:	Disabled
IP Address:	192.168.3.120
Subnet Mask:	255.255.255.0
Gateway IP Address:	
Web Server:	Enabled
Max Coils on Manifold (32 = Standard):	32
Safety Zones (Only configurable when Max Coils = 32):	None
COMM Fault / Idle Mode:	None
Numatics Part No. 240-181 Compatibility Mode:	1 Safe Zone
Diagnostic Word:	2 Safe Zones
I/O (Diagnostics) Status:	Mapped
Node Configuration Parameters:	3 Safe Zones
I/O Configuration:	Mapped
Quick Connect:	Unlocked
Display Orientation (Global):	Unlocked
Display Brightness:	Disabled
Comm. Format (I/O Data Padding):	Normal
	Medium
	SINT

Update Configuration

Safety Zone selection allows for a Maximum of 3 Zones. Safety Zone selection will not be available unless the Max Coils selection is set to (32).



Web Page may vary slightly for each supported protocol. Refer to specific protocol's Technical Manual for detail on commissioning. See Section 3.1 of this manual for supported protocols.

4. Zoned Safety Manifold Mapping

4.1 Zoned Safety Manifold Mapping

The Zoned Safety Manifold mapping section is meant to identify the mapping structure of the valve side of the manifold. Example #2 incorporates one input module (240-205) for reference. Any additional mapping structure related to the I/O side of the G3 electronics platform should be referenced in the appropriate Technical Manual for that protocol; see Section 3.1 of this manual.

Below is a full rendering (sections) of a Zoned Safety Manifold. In addition to the 3 Safe Zone sections, there are (32) additional standard coils that can be part of the assembly. These additional Non-Safe coils, like the Safety Manifold section, are controlled from the attached G3 Node. Each Safe Zone is identical in its functionality. They can be used to control separate adjacent cells or work stations and can incorporate different Safety Functions.

Also, identified below are additional examples of Zoned Safety Manifold configurations with various zones and Non-Safe sections.



The main power connection on the node only supplies valve power to the standard coils. Up to 32 standard coils can be used for general purpose applications.

503 Valve Platform

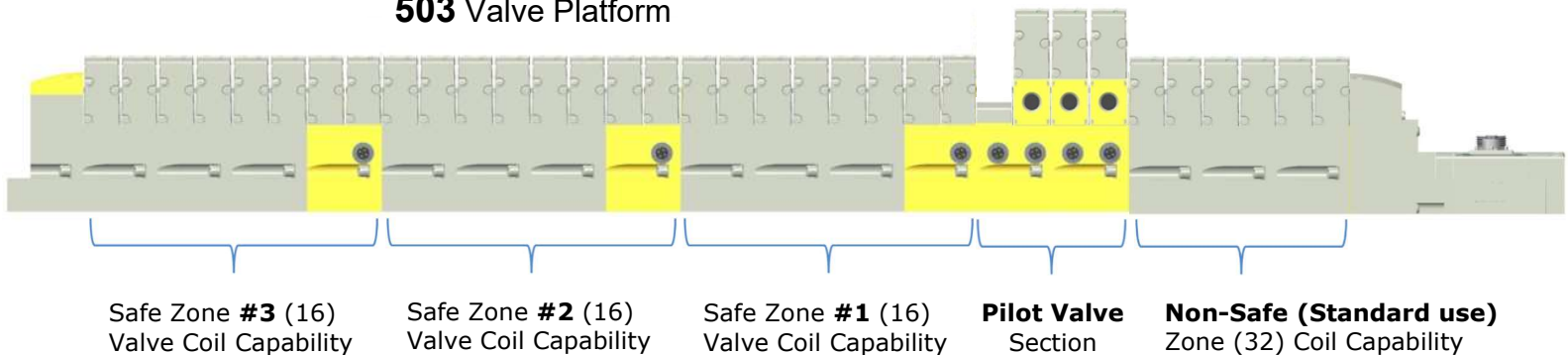

502 Valve Platform

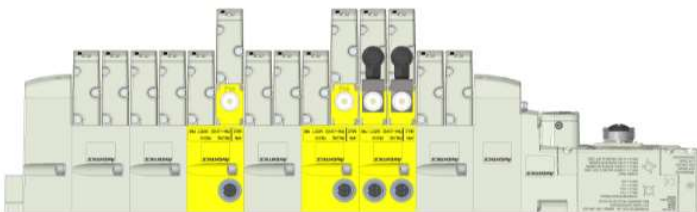

501 Valve Platform

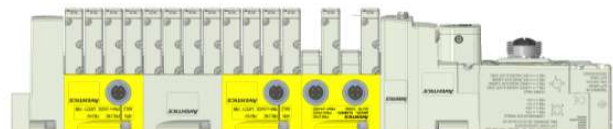

AVENTICS™ ZONED SAFETY MANIFOLD Technical Manual

4.2 Zoned Safety Manifold Data Sizing Worksheet (EtherNet/IP DLR Example)

Step

1 : Choose appropriate value and place the corresponding Input and Output Size values in the boxes labeled, "Valve Byte Requirements" at the bottom of the page. **Non-Safe data is always present; Safe-Zone data is selectable.**

2 : Choose up to sixteen modules to be included on the discrete I/O side of the manifold and place the sum of the corresponding input bytes and output bytes in the boxes labeled, "Sub-Bus Byte Requirements" at the bottom of the page.

3 : Total the input byte and output byte values from the boxes labeled "Sub-Bus Byte Requirements" and "Valve Byte Requirements" in the boxes labeled "Total Input and Output Bytes for Manifold. This is the total input and output byte values required for the configured manifold.

Valve Side

Step	Zoned Safety Valve Side	Description	Input Bytes		Output Bytes
			Status Enabled	Status Disabled	
1	Up to 32 Solenoid Coils	Standard Coil Area	4	0	4
	Up to 16 Solenoid Coils	Safe Zone #1	2	0	2
	Up to 16 Solenoid Coils	Safe Zone #2	2	0	2
	Up to 16 Solenoid Coils	Safe Zone #3	2	0	2

Digital Modules Byte Sizes

Step	Module No.	Description	Input Bytes		Output Bytes
			Status Enabled	Status Disabled	
2	240-203/204	16 Inputs - Terminal Strip	3	2	0
	240-205/209	16 Inputs - 8 x 12mm	3	2	0
	240-206/210	8 Inputs - 8 x 12mm	2	1	0
	240-207	16 Outputs - 8 x 12mm	2	0	2
	240-208	8 Outputs - 8 x 12mm	1	0	1
	240-211	8 Inputs / 8 Outputs - 8 x 12mm	3	1	1
	240-241	Sub - Bus Valve Output	4	0	4
	240-300	High Current 8 Outputs - 8 x 12mm	1	0	1
	240-316	8 Inputs - Terminal Strip	2	1	0
	240-323	16 Input - M23 Connector	3	2	0
	240-330	16 Output - Terminal Strip	2	0	2

Analog Modules Byte Sizes

Step	Module No.	Description	Input Bytes		Output Bytes
			Status Enabled	Status Disabled	
2	240-212/214	4 Inputs	10	8	0
	240-213/215/307	2 Inputs/ 2 Outputs	6	4	4
	240-311	4 RTD Inputs	10	8	0

Total Input (Status)/Output Size Calculation

Step	Module Position	Model Number	Input (Status)Bytes	Output Bytes
2	1 st			
	2 nd			
	3 rd			
	4 th			
	5 th			
	6 th			
	7 th			
	8 th			
	9 th			
	10 th			
	11 th			
	12 th			
	13 th			
	14 th			
	15 th			
	16 th			
1	Valve Side Byte Requirements:			
2	I/O Byte Requirements:			
	Optional Diagnostic Word:		2	0
3	Total Input and Output Bytes for Manifold			

AVENTICS™ ZONED SAFETY MANIFOLD Technical Manual

4.3 Zoned Safety Mapping Example #1 (EtherNet/IP DLR Node – 503)

Manifold Settings:

- (2) Safe Zones
- All "Safe Zone" stations wired for Double Solenoid
- Pilot Valve section valves are single solenoid
- All status bits enabled
- Standard valves are not represented

* U-Wiring Manifold/Valves not represented in Mapping Tables. Control of the Valves comes from external Safety Output device.

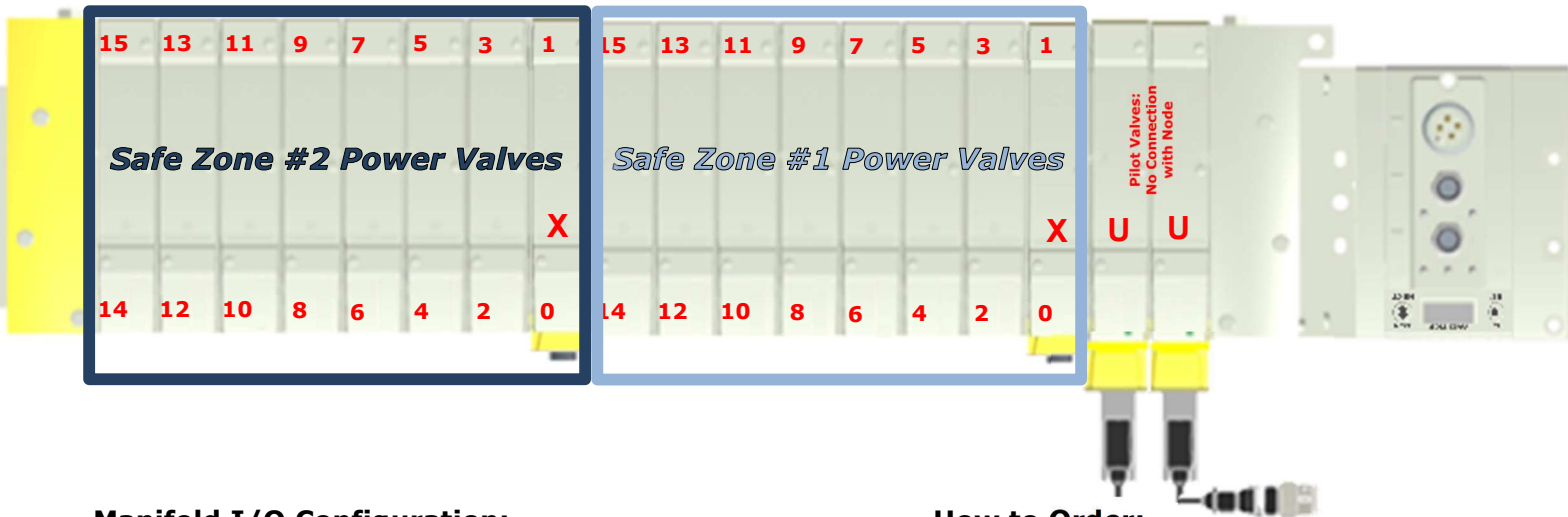

Manifold I/O Configuration:

Pos. No.	I/O Module Type (If Present)	Part No.	In	Out	Status
			Bytes		
1	NA	NA	NA	NA	NA
2	NA	NA	NA	NA	NA
3	NA	NA	NA	NA	NA
↓	↓	↓	↓	↓	↓
16	NA	NA	NA	NA	NA
Diagnostic Word			0	0	2
Standard Valve Size (Data Always Mapped)			0	4	4
Safe Zone #1			0	2	2
Safe Zone #2			0	2	2
Safe Zone #3			NA	NA	NA

Total: 0 8 10

How to Order:

STA	Part Number
	8503AV3R300VA45
Sta 1	R503A2B10M11MF1
	K503AU516663006
Sta 2	R503A2B10M11MF1
	K503AU516663010
	8503AMS22UA0010
Sta 3	R503A2B60MA00F1
	K503AP438300010
Sta 4	R503A2B60MA00F1
	8503AMM22X83H10
Sta 5	R503A2B60MA00F1
Sta 6	R503A2B60MA00F1
	8503AMM22MA0010
Sta 7	R503A2B60MA00F1
Sta 8	R503A2B60MA00F1
	8503AMM22MA0010
Sta 9	R503A2B60MA00F1
Sta 10	R503A2B60MA00F1
	8503AMM22MA0010
Sta 11	R503A2B60MA00F1
	K503AP438300010
Sta 12	R503A2B60MA00F1
	8503AMM22X83H10
Sta 13	R503A2B60MA00F1
Sta 14	R503A2B60MA00F1
	8503AMM22MA0010
Sta 15	R503A2B60MA00F1
Sta 16	R503A2B60MA00F1
	8503AMM22MA0010
Sta 17	R503A2B60MA00F1
Sta 18	R503A2B60MA00F1
	8503AMM22MA0010
	G3ED100R0STD
	ASSEMBLED

"X" and "U" Represent the location and type of manifold base option (Zoned Power / Pilot Valve). Refer to Section 2.2 and 2.3, page 7 for detailed information.

Coil numbering represents the numbering in the mapping tables on the next page. The recurring numbering and color-coded boxes define the individual zones. The "U-wiring" manifold bases are not controlled by the attached fieldbus node. Therefore, they are not represented in the mapping tables.

AVENTICS™ ZONED SAFETY MANIFOLD Technical Manual

I/O Table Mapping Example:

This example uses the RS Logix 5000 generic driver selection Data – "SINT – with status". The diagnostics and status data are written to a separate status table. Output bytes 0 – 3 are reserved for the general purpose non-safe valve section.

Example No. 1 Table Data: SINT – with status

Output Table								
BYTE	Bit 7	Bit 6	Bit 5	Bit 4	Bit 3	Bit 2	Bit 1	Bit 0
0	Allocated and Reserved	Allocated and Reserved	Allocated and Reserved	Allocated and Reserved	Allocated and Reserved	Allocated and Reserved	Allocated and Reserved	Allocated and Reserved
1	Allocated and Reserved	Allocated and Reserved	Allocated and Reserved	Allocated and Reserved	Allocated and Reserved	Allocated and Reserved	Allocated and Reserved	Allocated and Reserved
2	Allocated and Reserved	Allocated and Reserved	Allocated and Reserved	Allocated and Reserved	Allocated and Reserved	Allocated and Reserved	Allocated and Reserved	Allocated and Reserved
3	Allocated and Reserved	Allocated and Reserved	Allocated and Reserved	Allocated and Reserved	Allocated and Reserved	Allocated and Reserved	Allocated and Reserved	Allocated and Reserved
4	Zone No. 1 Coil No. 7	Zone No. 1 Coil No. 6	Zone No. 1 Coil No. 5	Zone No. 1 Coil No. 4	Zone No. 1 Coil No. 3	Zone No. 1 Coil No. 2	Zone No. 1 Coil No. 1	Zone No. 1 Coil No. 0
5	Zone No. 1 Coil No. 15	Zone No. 1 Coil No. 14	Zone No. 1 Coil No. 13	Zone No. 1 Coil No. 12	Zone No. 1 Coil No. 11	Zone No. 1 Coil No. 10	Zone No. 1 Coil No. 9	Zone No. 1 Coil No. 8
6	Zone No. 2 Coil No. 7	Zone No. 2 Coil No. 6	Zone No. 2 Coil No. 5	Zone No. 2 Coil No. 4	Zone No. 2 Coil No. 3	Zone No. 2 Coil No. 2	Zone No. 2 Coil No. 1	Zone No. 2 Coil No. 0
7	Zone No. 2 Coil No. 15	Zone No. 2 Coil No. 14	Zone No. 2 Coil No. 13	Zone No. 2 Coil No. 12	Zone No. 2 Coil No. 11	Zone No. 2 Coil No. 10	Zone No. 2 Coil No. 9	Zone No. 2 Coil No. 8

Input Table									
BYTE	Bit 7	Bit 6	Bit 5	Bit 4	Bit 3	Bit 2	Bit 1	Bit 0	
0	No Discrete Inputs Attached to Manifold Example								
1									

Status Table								
BYTE	Bit 7	Bit 6	Bit 5	Bit 4	Bit 3	Bit 2	Bit 1	Bit 0
0 (Optional)	Comm. Module Diag. Bit	Comm. Module Diag. Bit	Comm. Module Diag. Bit	Comm. Module Diag. Bit	Comm. Module Diag. Bit	Comm. Module Diag. Bit	Comm. Module Diag. Bit	Comm. Module Diag. Bit
1 (Optional)	Sub-bus Diag. Bit	Sub-bus Diag. Bit	Sub-bus Diag. Bit	Sub-bus Diag. Bit	Sub-bus Diag. Bit	Sub-bus Diag. Bit	Sub-bus Diag. Bit	Sub-bus Diag. Bit
2 (Optional)	Coil No. 7 Status	Coil No. 6 Status	Coil No. 5 Status	Coil No. 4 Status	Coil No. 3 Status	Coil No. 2 Status	Coil No. 1 Status	Coil No. 0 Status
3 (Optional)	Coil No. 15 Status	Coil No. 14 Status	Coil No. 13 Status	Coil No. 12 Status	Coil No. 11 Status	Coil No. 10 Status	Coil No. 9 Status	Coil No. 8 Status
4 (Optional)	Coil No. 23 Status	Coil No. 22 Status	Coil No. 21 Status	Coil No. 20 Status	Coil No. 19 Status	Coil No. 18 Status	Coil No. 17 Status	Coil No. 16 Status
5 (Optional)	Coil No. 31 Status	Coil No. 30 Status	Coil No. 29 Status	Coil No. 28 Status	Coil No. 27 Status	Coil No. 26 Status	Coil No. 25 Status	Coil No. 24 Status
6 (Optional)	Coil No. 7 Status	Coil No. 6 Status	Coil No. 5 Status	Coil No. 4 Status	Coil No. 3 Status	Coil No. 2 Status	Coil No. 1 Status	Coil No. 0 Status
7 (Optional)	Coil No. 15 Status	Coil No. 14 Status	Coil No. 13 Status	Coil No. 12 Status	Coil No. 11 Status	Coil No. 10 Status	Coil No. 9 Status	Coil No. 8 Status
8 (Optional)	Coil No. 7 Status	Coil No. 6 Status	Coil No. 5 Status	Coil No. 4 Status	Coil No. 3 Status	Coil No. 2 Status	Coil No. 1 Status	Coil No. 0 Status
9 (Optional)	Coil No. 15 Status	Coil No. 14 Status	Coil No. 13 Status	Coil No. 12 Status	Coil No. 11 Status	Coil No. 10 Status	Coil No. 9 Status	Coil No. 8 Status

AVENTICS™ ZONED SAFETY MANIFOLD Technical Manual

4.4 Zoned Safety Mapping Example #2 (EtherNet/IP DLR Node – 503)

Manifold Settings:

- (1) Safe Zones
- All "Safe Zone" stations wired for Double Solenoid
- Pilot Valve section valves are single solenoid
- All status bits enabled
- Standard valves are represented

* U-Wiring Manifold/Valves not represented in Mapping Tables. Control of the Valves comes from external Safety Output device.

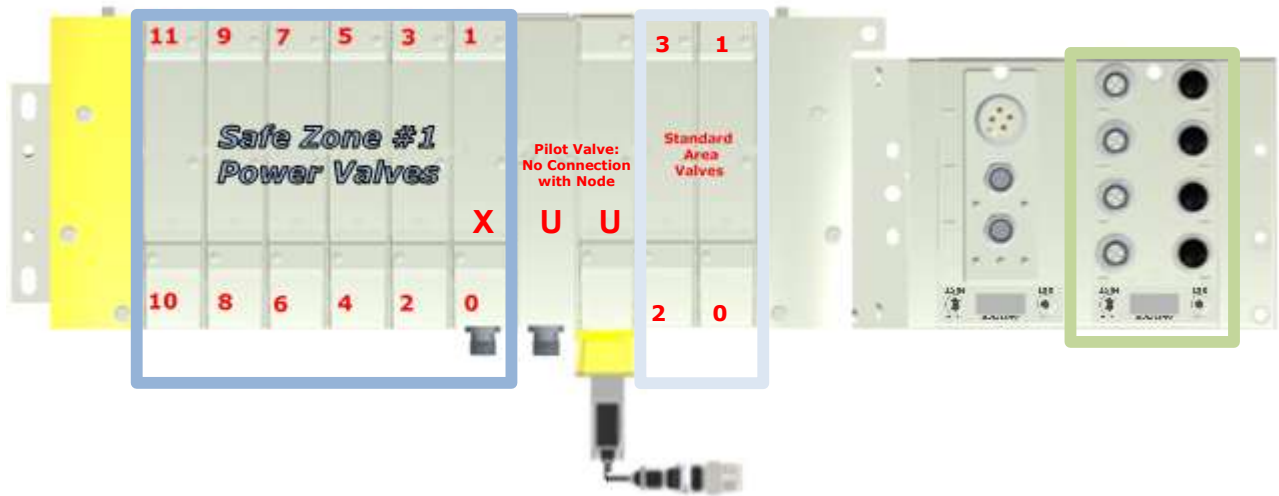

Manifold I/O Configuration:

Pos. No.	I/O Module Type (If Present)	Part No.	In	Out	Status
			Bytes		
1	16I PNP	240-205	2	0	1
2	NA	NA	NA	NA	NA
3	NA	NA	NA	NA	NA
↓	↓	↓	↓	↓	↓
16	NA	NA	NA	NA	NA
Diagnostic Word			0	0	2
Standard Valve Size (Data Always Mapped)			0	4	4
Safe Zone #1			0	2	2
Safe Zone #2			NA	NA	NA
Safe Zone #3			NA	NA	NA

Total: 2 6 9

"X" and "U" Represent the location and type of manifold base option (Zoned Power / Pilot Valve). Refer to Section 2.2 and 2.3, page 7 for detailed information. Coil numbering represents the numbering in the mapping tables on the next page. The recurring numbering and color-coded boxes define the individual zones. The "U-wiring" manifold bases are not controlled by the attached fieldbus node. Therefore, they are not represented in the mapping tables.

How to Order:

STA	Part Number
	8503AV3J300VA00
Sta 1	R503A2B40MA00F1
Sta 2	R503A2B40MA00F1
	8503AMM22MA0010
Sta 3	R503A2B10M11MF1
	8503AU516663005
Sta 4	P503AB428359001
	8503AMS22UA0010
Sta 5	R503A2B60MA00F1
Sta 6	R503A2B60MA00F1
	8503AMM22XA0010
Sta 7	R503A2B60MA00F1
Sta 8	R503A2B60MA00F1
	8503AMM22MA0010
Sta 9	R503A2B60MA00F1
Sta 10	R503A2B60MA00F1
	8503AMM22MA0010
	G3ED101R0STD
	ASSEMBLED

AVENTICS™ ZONED SAFETY MANIFOLD Technical Manual

I/O Table Mapping Example:

This example uses the RS Logix 5000 generic driver selection Data – "SINT – with status". The diagnostics and status data are written to a separate status table. Output bytes 0 – 3 are reserved for the general purpose non-safe valve section.

Example No. 2 Table Data: SINT – with status

Output Table								
BYTE	Bit 7	Bit 6	Bit 5	Bit 4	Bit 3	Bit 2	Bit 1	Bit 0
0	Allocated and Reserved	Allocated and Reserved	Allocated and Reserved	Allocated and Reserved	Non-Safe Coil No. 3	Non-Safe Coil No. 2	Non-Safe Coil No. 1	Non-Safe Coil No. 0
1	Allocated and Reserved	Allocated and Reserved	Allocated and Reserved	Allocated and Reserved	Allocated and Reserved	Allocated and Reserved	Allocated and Reserved	Allocated and Reserved
2	Allocated and Reserved	Allocated and Reserved	Allocated and Reserved	Allocated and Reserved	Allocated and Reserved	Allocated and Reserved	Allocated and Reserved	Allocated and Reserved
3	Allocated and Reserved	Allocated and Reserved	Allocated and Reserved	Allocated and Reserved	Allocated and Reserved	Allocated and Reserved	Allocated and Reserved	Allocated and Reserved
4	Zone No. 1 Coil No. 7	Zone No. 1 Coil No. 6	Zone No. 1 Coil No. 5	Zone No. 1 Coil No. 4	Zone No. 1 Coil No. 3	Zone No. 1 Coil No. 2	Zone No. 1 Coil No. 1	Zone No. 1 Coil No. 0
5	Allocated and Reserved	Allocated and Reserved	Allocated and Reserved	Allocated and Reserved	Zone No. 1 Coil No. 11	Zone No. 1 Coil No. 10	Zone No. 1 Coil No. 9	Zone No. 1 Coil No. 8

Input Table								
BYTE	Bit 7	Bit 6	Bit 5	Bit 4	Bit 3	Bit 2	Bit 1	Bit 0
0	Discrete Input No. 7	Discrete Input No. 6	Discrete Input No. 5	Discrete Input No. 4	Discrete Input No. 3	Discrete Input No. 2	Discrete Input No. 1	Discrete Input No. 0
1	Discrete Input No. 15	Discrete Input No. 14	Discrete Input No. 13	Discrete Input No. 12	Discrete Input No. 11	Discrete Input No. 10	Discrete Input No. 9	Discrete Input No. 8

Status Table								
BYTE	Bit 7	Bit 6	Bit 5	Bit 4	Bit 3	Bit 2	Bit 1	Bit 0
0 (Optional)	Comm. Module Diag. Bit	Comm. Module Diag. Bit	Comm. Module Diag. Bit	Comm. Module Diag. Bit	Comm. Module Diag. Bit	Comm. Module Diag. Bit	Comm. Module Diag. Bit	Comm. Module Diag. Bit
1 (Optional)	Sub-bus Diag. Bit	Sub-bus Diag. Bit	Sub-bus Diag. Bit	Sub-bus Diag. Bit	Sub-bus Diag. Bit	Sub-bus Diag. Bit	Sub-bus Diag. Bit	Sub-bus Diag. Bit
2 (Optional)	Non-Safe Coil No. 7 Status	Non-Safe Coil No. 6 Status	Non-Safe Coil No. 5 Status	Non-Safe Coil No. 4 Status	Non-Safe Coil No. 3 Status	Non-Safe Coil No. 2 Status	Non-Safe Coil No. 1 Status	Non-Safe Coil No. 0 Status
3 (Optional)	Non-Safe Coil No. 15 Status	Non-Safe Coil No. 14 Status	Non-Safe Coil No. 13 Status	Non-Safe Coil No. 12 Status	Non-Safe Coil No. 11 Status	Non-Safe Coil No. 10 Status	Non-Safe Coil No. 9 Status	Non-Safe Coil No. 8 Status
4 (Optional)	Non-Safe Coil No. 23 Status	Non-Safe Coil No. 22 Status	Non-Safe Coil No. 21 Status	Non-Safe Coil No. 20 Status	Non-Safe Coil No. 19 Status	Non-Safe Coil No. 18 Status	Non-Safe Coil No. 17 Status	Non-Safe Coil No. 16 Status
5 (Optional)	Non-Safe Coil No. 31 Status	Non-Safe Coil No. 30 Status	Non-Safe Coil No. 29 Status	Non-Safe Coil No. 28 Status	Non-Safe Coil No. 27 Status	Non-Safe Coil No. 26 Status	Non-Safe Coil No. 25 Status	Non-Safe Coil No. 24 Status
6 (Optional)	Coil No. 7 Status	Coil No. 6 Status	Coil No. 5 Status	Coil No. 4 Status	Coil No. 3 Status	Coil No. 2 Status	Coil No. 1 Status	Coil No. 0 Status
7 (Optional)	Coil No. 15 Status	Coil No. 14 Status	Coil No. 13 Status	Coil No. 12 Status	Coil No. 11 Status	Coil No. 10 Status	Coil No. 9 Status	Coil No. 8 Status

AVENTICS™ ZONED SAFETY MANIFOLD Technical Manual

4.5 Zoned Safety Mapping Example #3 (EtherNet/IP DLR Node – 501)

Manifold Settings:

- (1) Safe Zones
- All "Safe Zone" stations wired for Double Solenoid
- Pilot Valve section valves are single solenoid
- All status bits enabled
- Standard valves are not represented

* U-Wiring Manifold/Valves not represented in Mapping Tables. Control of the Valves comes from external Safety Output device.

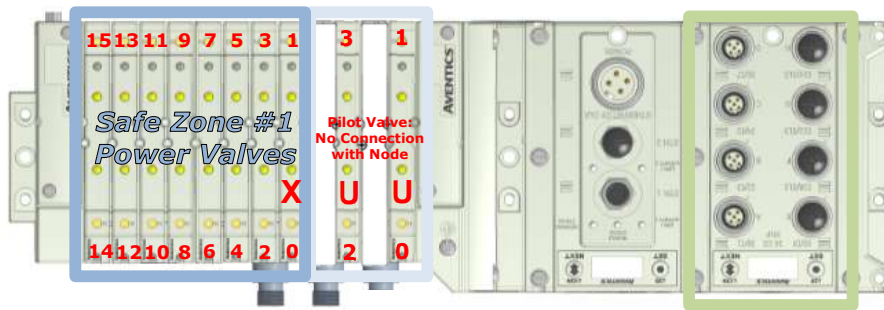

Manifold I/O Configuration:

Pos. No.	I/O Module Type (If Present)	Part No.	In	Out	Status
			Bytes		
1	16I PNP	240-205	2	0	1
2	NA	NA	NA	NA	NA
3	NA	NA	NA	NA	NA
↓	↓	↓	↓	↓	↓
16	NA	NA	NA	NA	NA
Diagnostic Word			0	0	2
Standard Valve Size (Data Always Mapped)			0	4	4
Safe Zone #1			0	2	2
Safe Zone #2			NA	NA	NA
Safe Zone #3			NA	NA	NA

Total: 2 6 9

"X" and "U" Represent the location and type of manifold base option (Zoned Power / Pilot Valve). Refer to Section 2.2 and 2.3, page 7 for detailed information. Coil numbering represents the numbering in the mapping tables on the next page. The recurring numbering and color-coded boxes define the individual zones. The "U-wiring" manifold bases are not controlled by the attached fieldbus node. Therefore, they are not represented in the mapping tables.

How to Order:

STA	Part Number
	K501AV3L200VMUF
Sta 1	R501A2B10M11MF1
Sta 2	P501AB429685001
Sta 3	R501A2B10M11MF1
Sta 4	P501AB429685001
	K501AMS42UA0010
Sta 5	R501A2B60MA00F1
Sta 6	R501A2B60MA00F1
Sta 7	R501A2B60MA00F1
Sta 8	R501A2B60MA00F1
	K501AMM42XA0010
Sta 9	R501A2B60MA00F1
Sta 10	R501A2B60MA00F1
Sta 11	R501A2B60MA00F1
Sta 12	R501A2B60MA00F1
	K501AMM42MA0010
	8503AMM22MA0010
	G3ED101R0STD
	240-205
	ASSEMBLED

AVENTICS™ ZONED SAFETY MANIFOLD Technical Manual

I/O Table Mapping Example:

This example uses the RS Logix 5000 generic driver selection Data – "SINT – with status". The diagnostics and status data are written to a separate status table. Output bytes 0 – 3 are reserved for the general purpose non-safe valve section.

Example No. 3 Table Data: SINT – with status

Output Table								
BYTE	Bit 7	Bit 6	Bit 5	Bit 4	Bit 3	Bit 2	Bit 1	Bit 0
0	Allocated and Reserved	Allocated and Reserved	Allocated and Reserved	Allocated and Reserved	Allocated and Reserved	Allocated and Reserved	Allocated and Reserved	Allocated and Reserved
1	Allocated and Reserved	Allocated and Reserved	Allocated and Reserved	Allocated and Reserved	Allocated and Reserved	Allocated and Reserved	Allocated and Reserved	Allocated and Reserved
2	Allocated and Reserved	Allocated and Reserved	Allocated and Reserved	Allocated and Reserved	Allocated and Reserved	Allocated and Reserved	Allocated and Reserved	Allocated and Reserved
3	Allocated and Reserved	Allocated and Reserved	Allocated and Reserved	Allocated and Reserved	Allocated and Reserved	Allocated and Reserved	Allocated and Reserved	Allocated and Reserved
4	Zone No. 1 Coil No. 7	Zone No. 1 Coil No. 6	Zone No. 1 Coil No. 5	Zone No. 1 Coil No. 4	Zone No. 1 Coil No. 3	Zone No. 1 Coil No. 2	Zone No. 1 Coil No. 1	Zone No. 1 Coil No. 0
5	Zone No. 1 Coil No. 15	Zone No. 1 Coil No. 14	Zone No. 1 Coil No. 13	Zone No. 1 Coil No. 12	Zone No. 1 Coil No. 11	Zone No. 1 Coil No. 10	Zone No. 1 Coil No. 9	Zone No. 1 Coil No. 8

Input Table								
BYTE	Bit 7	Bit 6	Bit 5	Bit 4	Bit 3	Bit 2	Bit 1	Bit 0
0	Discrete Input No. 7	Discrete Input No. 6	Discrete Input No. 5	Discrete Input No. 4	Discrete Input No. 3	Discrete Input No. 2	Discrete Input No. 1	Discrete Input No. 0
1	Discrete Input No. 15	Discrete Input No. 14	Discrete Input No. 13	Discrete Input No. 12	Discrete Input No. 11	Discrete Input No. 10	Discrete Input No. 9	Discrete Input No. 8

Status Table								
BYTE	Bit 7	Bit 6	Bit 5	Bit 4	Bit 3	Bit 2	Bit 1	Bit 0
0 (Optional)	Comm. Module Diag. Bit	Comm. Module Diag. Bit	Comm. Module Diag. Bit	Comm. Module Diag. Bit	Comm. Module Diag. Bit	Comm. Module Diag. Bit	Comm. Module Diag. Bit	Comm. Module Diag. Bit
1 (Optional)	Sub-bus Diag. Bit	Sub-bus Diag. Bit	Sub-bus Diag. Bit	Sub-bus Diag. Bit	Sub-bus Diag. Bit	Sub-bus Diag. Bit	Sub-bus Diag. Bit	Sub-bus Diag. Bit
2 (Optional)	Coil No. 7 Status	Coil No. 6 Status	Coil No. 5 Status	Coil No. 4 Status	Coil No. 3 Status	Coil No. 2 Status	Coil No. 1 Status	Coil No. 0 Status
3 (Optional)	Coil No. 15 Status	Coil No. 14 Status	Coil No. 13 Status	Coil No. 12 Status	Coil No. 11 Status	Coil No. 10 Status	Coil No. 9 Status	Coil No. 8 Status
4 (Optional)	Coil No. 23 Status	Coil No. 22 Status	Coil No. 21 Status	Coil No. 20 Status	Coil No. 19 Status	Coil No. 18 Status	Coil No. 17 Status	Coil No. 16 Status
5 (Optional)	Coil No. 31 Status	Coil No. 30 Status	Coil No. 29 Status	Coil No. 28 Status	Coil No. 27 Status	Coil No. 26 Status	Coil No. 25 Status	Coil No. 24 Status
6 (Optional)	Coil No. 7 Status	Coil No. 6 Status	Coil No. 5 Status	Coil No. 4 Status	Coil No. 3 Status	Coil No. 2 Status	Coil No. 1 Status	Coil No. 0 Status
7 (Optional)	Coil No. 15 Status	Coil No. 14 Status	Coil No. 13 Status	Coil No. 12 Status	Coil No. 11 Status	Coil No. 10 Status	Coil No. 9 Status	Coil No. 8 Status

5. Zoned Safety Web Server

The Web Server for all supported protocols (see Sec. 3.1), have been upgraded to support the Zoned Safety Manifold functionality. The changes to each supported protocol web server, includes only two of the available tabs; the **Node Configuration** and **Diagnostics**. This section will only detail the changes of these two tabs, related to the Zoned Safety Manifold. For complete web server detail, refer to the Technical Manual for the desired protocol. The example screen shots are based on an EtherNet/IP DLR node. Some of the identified tabs will change per protocol. The Zoned Safety parameter on the Node Configuration tab will be the same for all protocols, and the feature set for the Diagnostics tab will be the same.

5.1 Node Configuration

The Node Configuration tab allows the user to configure and set the various parameters identified below. Related to this topic is the Safety Zones tab that allows for the configuration and setting of the specific number of Safe Zones connected to the node; for further detail refer to Section 3.3.

Node Configuration (Green selections denote Factory Default settings)	
DHCP:	Disabled
IP Address:	192.168.3.120
Subnet Mask:	255.255.255.0
Gateway IP Address:	
Web Server:	Enabled
Max Coils on Manifold (32 = Standard):	32
Safety Zones (Only configurable when Max Coils = 32):	None
COMM Fault / Idle Mode:	Turn OFF All Outputs
Numatics Part No. 240-181 Compatibility Mode:	Disabled
Diagnostic Word:	Mapped
I/O (Diagnostics) Status:	Mapped
Node Configuration Parameters:	Unlocked
I/O Configuration:	Unlocked
Quick Connect:	Disabled
Display Orientation (Global):	Normal
Display Brightness:	Medium
Comm. Format (I/O Data Padding):	SINT

Update Configuration

AVENTICS™ ZONED SAFETY MANIFOLD Technical Manual

5.2 Diagnostics

The Diagnostics tab allows the user to monitor all attached I/O connected to the Zoned Safety Manifold; as well as "force on" all attached valves and Outputs. Additional features include the ability to monitor different values like Firmware Revisions, Serial Number, Etc. The sample scree shot below identifies "two" Zoned Power Manifold Bases are attached to the EtherNet/IP manifold; therefore, there are "two" Safe Zones.

The screenshot displays the AVENTICS diagnostic interface. At the top, there is a navigation bar with the following tabs: Home, Node Configuration, Node Password, Diagnostics (selected), Studio 5000 Config, Quick Start Manual, Download EDS, and Help. Below the navigation bar is a table of modules:

Module	Part No.	Description	Details	Activity
Node	240-325	EtherNet/IP DLR/QC Communications Module	<input type="checkbox"/> Show Details	Close all Details <input checked="" type="checkbox"/>
Valve Driver	P599AE42518800x	50X Series Valve Driver Output Module	<input checked="" type="checkbox"/> Show Details	Close all Details <input checked="" type="checkbox"/>

The detailed view for the Valve Driver module shows the following information:

- Firmware Revision:** 4.13
- Show Valve Coils 0-31: Check/Uncheck box to force/un-force valve coil
- Valve Status:**
 - = Shorted Coil
 - = Open Coil
 - ✕ = No Coil Detected
- Show Safety Zone 1, Valve Coils 32-47:
- Show Safety Zone 2, Valve Coils 48-63:
- Show I/O Mappings and Sizes

The valve status table below shows the status of 32 coils (0-31):

0	1	2	3	4	5	6	7
8	9	10	11	12	13	14	15
16	17	18	19	20	21	22	23
24	25	26	27	28	29	30	31
0 ✕	1 ✕	2 ✕	3 ✕	4 ✕	5 ✕	6 ✕	7 ✕
8 ✕	9 ✕	10 ✕	11 ✕	12 ✕	13 ✕	14 ✕	15 ✕
16 ✕	17 ✕	18 ✕	19 ✕	20 ✕	21 ✕	22 ✕	23 ✕
24 ✕	25 ✕	26 ✕	27 ✕	28 ✕	29 ✕	30 ✕	31 ✕

At the bottom of the interface, there is another module entry:

No.	Part No.	Description	Details	Activity
No. 1	240-205	16 Inputs PNP Digital M12 x 8	<input type="checkbox"/> Show Details	Close all Details <input checked="" type="checkbox"/>
			<input checked="" type="checkbox"/> Show Error/Event Log	

AVENTICS™ ZONED SAFETY MANIFOLD Technical Manual



[Home](#)
[Node Configuration](#)
[Node Password](#)
[Diagnostics](#)
[Studio 5000 Config](#)
[Quick Start Manual](#)
[Download EDS](#)
[Help](#)

Module	Part No.	Description	Details	Export Config and Log	Activity					
Node	240-325	EtherNet/IP DLR/QC Communications Module	<input type="checkbox"/> Show Details	<input type="button" value="Close all Details"/>						
Valve Driver	P599AE42518800x	Gen. 50X Series Valve Driver Output Module	<input checked="" type="checkbox"/> Show Details	<input type="button" value="Close all Details"/>						
 <div style="border: 1px solid red; padding: 2px; margin: 5px;">Zone #1 Expanded</div> <div style="border: 1px solid red; padding: 2px; margin: 5px;">Zone #2 Expanded</div>	Firmware Revision:		4.13							
	<input checked="" type="checkbox"/> Show Valve Coils 0-31: Check/Uncheck box to force/un-force valve coil		0 <input checked="" type="checkbox"/>	1 <input type="checkbox"/>	2 <input checked="" type="checkbox"/>	3 <input checked="" type="checkbox"/>	4 <input checked="" type="checkbox"/>	5 <input type="checkbox"/>	6 <input type="checkbox"/>	7 <input type="checkbox"/>
			8 <input type="checkbox"/>	9 <input type="checkbox"/>	10 <input type="checkbox"/>	11 <input type="checkbox"/>	12 <input type="checkbox"/>	13 <input type="checkbox"/>	14 <input type="checkbox"/>	15 <input type="checkbox"/>
			16 <input type="checkbox"/>	17 <input type="checkbox"/>	18 <input checked="" type="checkbox"/>	19 <input checked="" type="checkbox"/>	20 <input checked="" type="checkbox"/>	21 <input checked="" type="checkbox"/>	22 <input checked="" type="checkbox"/>	23 <input checked="" type="checkbox"/>
			24 <input checked="" type="checkbox"/>	25 <input checked="" type="checkbox"/>	26 <input checked="" type="checkbox"/>	27 <input checked="" type="checkbox"/>	28 <input checked="" type="checkbox"/>	29 <input checked="" type="checkbox"/>	30 <input checked="" type="checkbox"/>	31 <input checked="" type="checkbox"/>
	Valve Status:		0 <input checked="" type="checkbox"/>	1 <input checked="" type="checkbox"/>	2 <input checked="" type="checkbox"/>	3 <input checked="" type="checkbox"/>	4 <input checked="" type="checkbox"/>	5 <input checked="" type="checkbox"/>	6 <input checked="" type="checkbox"/>	7 <input checked="" type="checkbox"/>
	● = Shorted Coil		8 <input checked="" type="checkbox"/>	9 <input checked="" type="checkbox"/>	10 <input checked="" type="checkbox"/>	11 <input checked="" type="checkbox"/>	12 <input checked="" type="checkbox"/>	13 <input checked="" type="checkbox"/>	14 <input checked="" type="checkbox"/>	15 <input checked="" type="checkbox"/>
	● = Open Coil		16 <input checked="" type="checkbox"/>	17 <input checked="" type="checkbox"/>	18 <input checked="" type="checkbox"/>	19 <input checked="" type="checkbox"/>	20 <input checked="" type="checkbox"/>	21 <input checked="" type="checkbox"/>	22 <input checked="" type="checkbox"/>	23 <input checked="" type="checkbox"/>
	✕ = No Coil Detected		24 <input checked="" type="checkbox"/>	25 <input checked="" type="checkbox"/>	26 <input checked="" type="checkbox"/>	27 <input checked="" type="checkbox"/>	28 <input checked="" type="checkbox"/>	29 <input checked="" type="checkbox"/>	30 <input checked="" type="checkbox"/>	31 <input checked="" type="checkbox"/>
	<input checked="" type="checkbox"/> Show Safety Zone 1, Valve Coils 32-47: Check/Uncheck box to force/un-force valve coil		32 <input type="checkbox"/>	33 <input checked="" type="checkbox"/>	34 <input type="checkbox"/>	35 <input checked="" type="checkbox"/>	36 <input type="checkbox"/>	37 <input checked="" type="checkbox"/>	38 <input type="checkbox"/>	39 <input checked="" type="checkbox"/>
		40 <input type="checkbox"/>	41 <input type="checkbox"/>	42 <input type="checkbox"/>	43 <input type="checkbox"/>	44 <input type="checkbox"/>	45 <input type="checkbox"/>	46 <input type="checkbox"/>	47 <input type="checkbox"/>	
Valve Status:		32 <input type="checkbox"/>	33 <input type="checkbox"/>	34 <input type="checkbox"/>	35 <input type="checkbox"/>	36 <input type="checkbox"/>	37 <input type="checkbox"/>	38 <input type="checkbox"/>	39 <input type="checkbox"/>	
● = Shorted Coil		40 <input type="checkbox"/>	41 <input type="checkbox"/>	42 <input type="checkbox"/>	43 <input type="checkbox"/>	44 <input type="checkbox"/>	45 <input type="checkbox"/>	46 <input type="checkbox"/>	47 <input type="checkbox"/>	
● = Open Coil		40 <input type="checkbox"/>	41 <input type="checkbox"/>	42 <input type="checkbox"/>	43 <input type="checkbox"/>	44 <input type="checkbox"/>	45 <input type="checkbox"/>	46 <input type="checkbox"/>	47 <input type="checkbox"/>	
✕ = No Coil Detected		40 <input type="checkbox"/>	41 <input type="checkbox"/>	42 <input type="checkbox"/>	43 <input type="checkbox"/>	44 <input type="checkbox"/>	45 <input type="checkbox"/>	46 <input type="checkbox"/>	47 <input type="checkbox"/>	
<input checked="" type="checkbox"/> Show Safety Zone 2, Valve Coils 48-63: Check/Uncheck box to force/un-force valve coil		48 <input type="checkbox"/>	49 <input checked="" type="checkbox"/>	50 <input type="checkbox"/>	51 <input checked="" type="checkbox"/>	52 <input type="checkbox"/>	53 <input checked="" type="checkbox"/>	54 <input type="checkbox"/>	55 <input checked="" type="checkbox"/>	
		56 <input type="checkbox"/>	57 <input type="checkbox"/>	58 <input type="checkbox"/>	59 <input type="checkbox"/>	60 <input type="checkbox"/>	61 <input type="checkbox"/>	62 <input type="checkbox"/>	63 <input type="checkbox"/>	
Valve Status:		48 <input type="checkbox"/>	49 <input type="checkbox"/>	50 <input type="checkbox"/>	51 <input type="checkbox"/>	52 <input type="checkbox"/>	53 <input type="checkbox"/>	54 <input type="checkbox"/>	55 <input type="checkbox"/>	
● = Shorted Coil		48 <input type="checkbox"/>	49 <input type="checkbox"/>	50 <input type="checkbox"/>	51 <input type="checkbox"/>	52 <input type="checkbox"/>	53 <input type="checkbox"/>	54 <input type="checkbox"/>	55 <input type="checkbox"/>	
● = Open Coil		48 <input type="checkbox"/>	49 <input type="checkbox"/>	50 <input type="checkbox"/>	51 <input type="checkbox"/>	52 <input type="checkbox"/>	53 <input type="checkbox"/>	54 <input type="checkbox"/>	55 <input type="checkbox"/>	
✕ = No Coil Detected		48 <input type="checkbox"/>	49 <input type="checkbox"/>	50 <input type="checkbox"/>	51 <input type="checkbox"/>	52 <input type="checkbox"/>	53 <input type="checkbox"/>	54 <input type="checkbox"/>	55 <input type="checkbox"/>	
<input type="checkbox"/> Show I/O Mappings and Sizes		56 <input type="checkbox"/>	57 <input type="checkbox"/>	58 <input type="checkbox"/>	59 <input type="checkbox"/>	60 <input type="checkbox"/>	61 <input type="checkbox"/>	62 <input type="checkbox"/>	63 <input type="checkbox"/>	
No. 1	240-205	16 Inputs PNP Digital M12 x 8	<input type="checkbox"/> Show Details	<input type="button" value="Close all Details"/>						
			<input type="checkbox"/> Show Error/Event Log							

Safety Zones 1 and 2 have been expanded in the screen shot above to show web page representation. Coil data shown is representative of the EtherNet/IP DLR manifold connected.



TDG3ZSTM1-5EN 08/20
Subject to change without notice

www.asco.com

6. Zoned Safety Circuit Examples/Analysis

6.1 Example #1 Automated Assembly Machine

The example is based on an automatic assembly machine, with manual loading and unloading of the work piece. It has been determined, based on the Risk Assessment, that the loading/unloading station requires Risk Reduction to make it safe. It has also been determined that the Safety Function requires the motion (Actuators) to stop when the Safety Function is initiated. It has also been determined that the required Category and PL_r required, based on ISO 13849-1 is, Category 3 PL_d.

The tooling in the load/unload area has four clamps that hold a work piece during the machine process. The four clamps are represented by Actuators A1, A2, A3 and A4 in the pneumatic circuit.

This analysis only considers the pneumatic control, in the form of a sub-system. Additional Safety-Related control components (e.g. protective devices, electrical logic elements, etc.) must be evaluated in the form of a sub-system for a complete evaluation of the Safety Function.

Safety Function: Safety Related Stop and Unexpected Startup

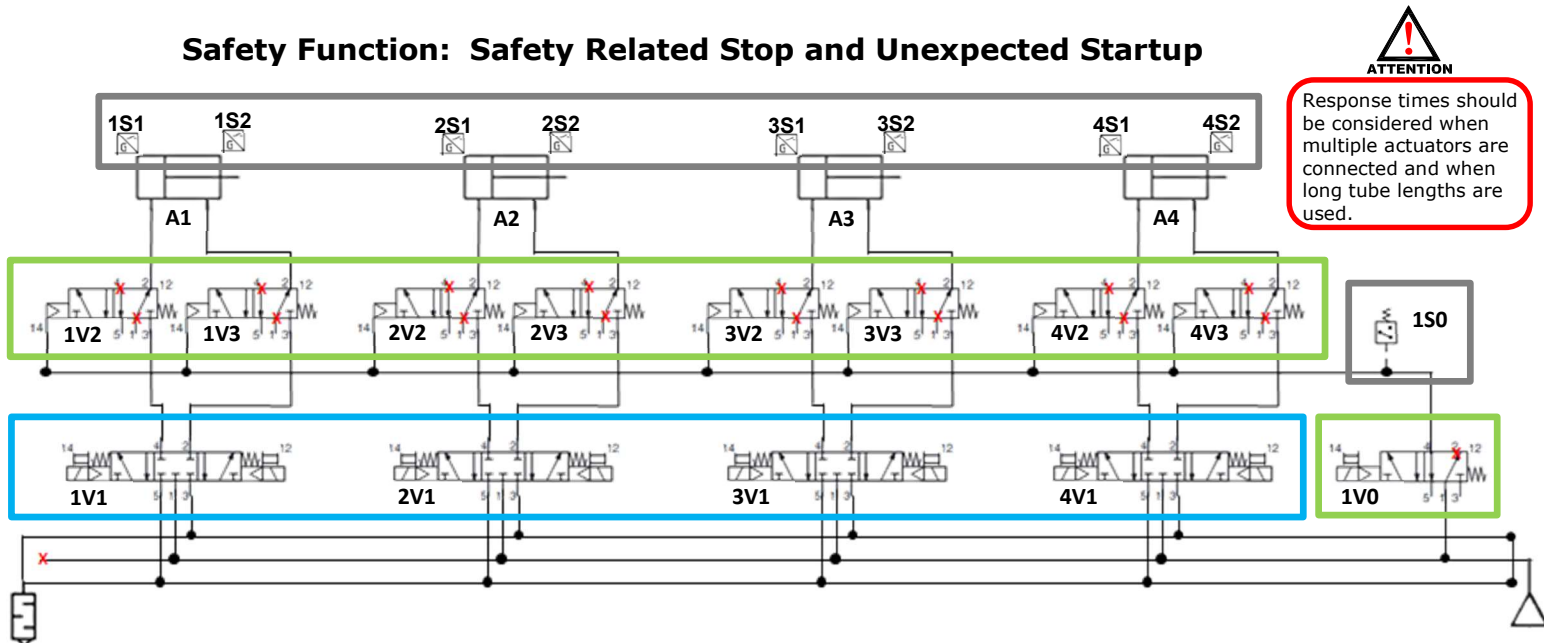

The Safety Functions can be applied to each individual actuator (A1, A2, A3 and A4); however, they can be considered a single Safety Function since they are implemented utilizing the same SRP/CS. Each Actuators Safety Function is executed at the same time.

The Safety related block diagram identified below identifies the pneumatic SRP of the Zoned Safety Manifold and how they are separated into Channels

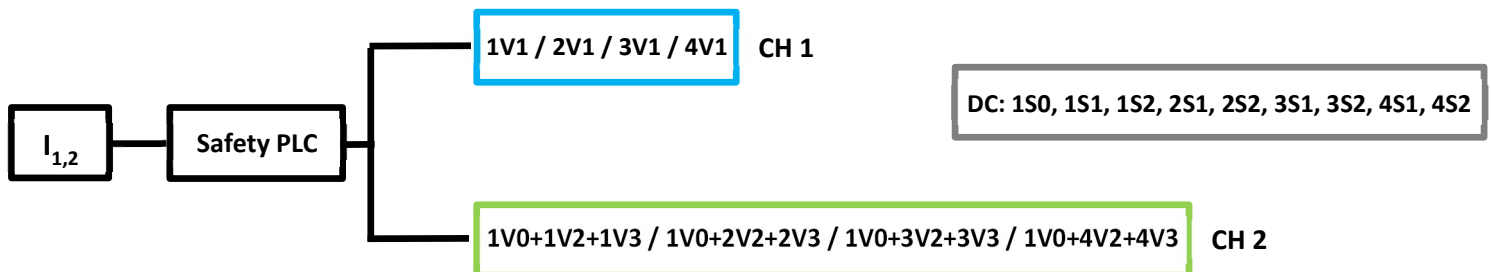

AVENTICS™ ZONED SAFETY MANIFOLD Technical Manual

The physical representation of the Zoned Safety Manifold is identified in the diagram below. Included are the required external elements (e.g. Pilot Operated Spring Return Valves) to achieve a redundant circuit(s). The colored boxes represent the channels identified in the Safety Block diagram shown on the previous page.

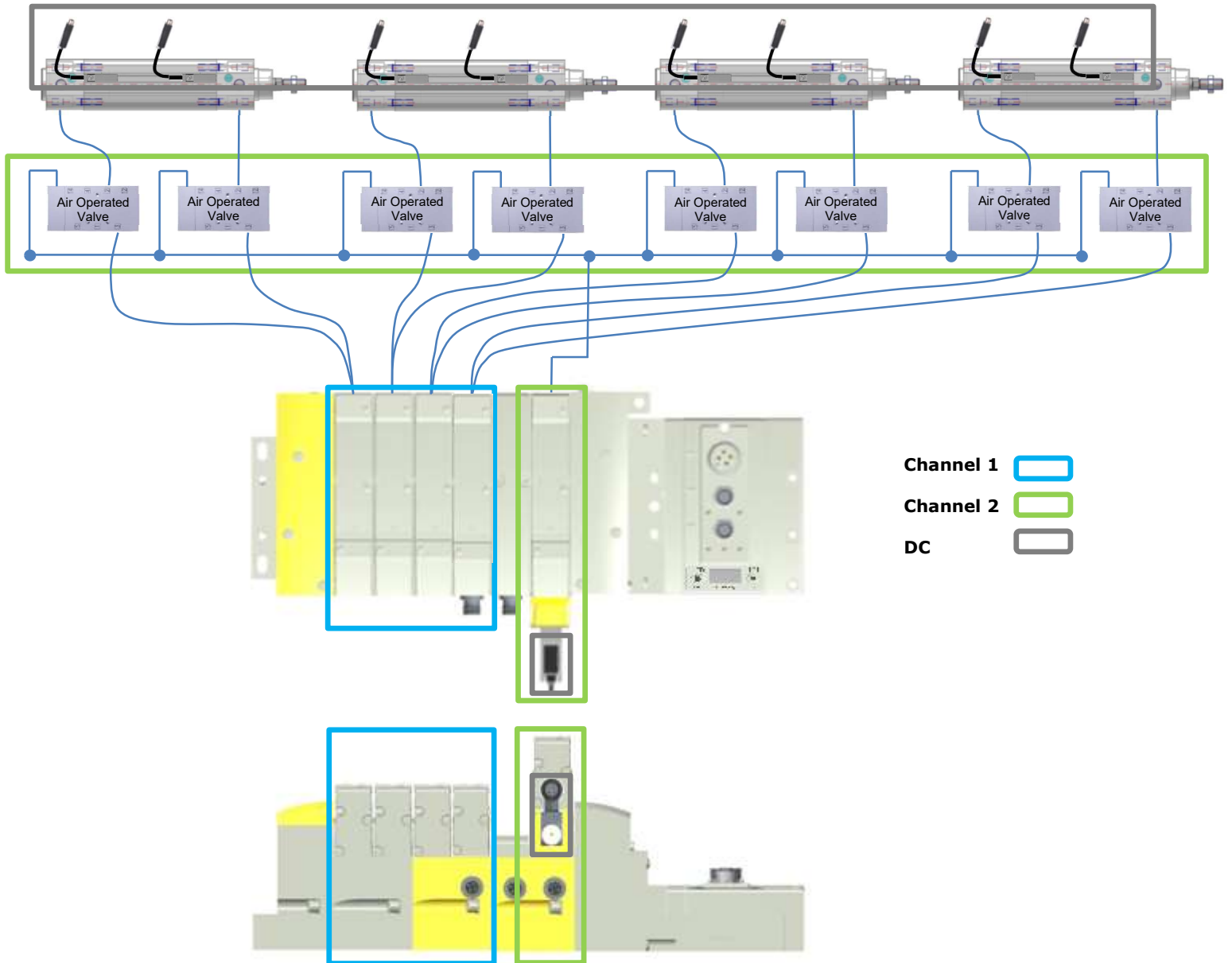

When valves with Manual overrides are selected for the U-Wiring and X-Wiring manifold blocks, adequate measures must be taken to prevent any hazardous situations that may occur (e.g. use the diagnostic feedback of the DC elements as identification on a display that a valve is manually overridden).

AVENTICS™ ZONED SAFETY MANIFOLD Technical Manual

The following evaluation of MTTFd, DC, CCF, etc. for Example #1 circuit, only includes the Pneumatic portion (SRP) as a sub-system identified in the red box below. All other SRP (e.g. protective devices, electrical logic elements) must be evaluated in the form of a sub-system for a complete evaluation of the safety function.

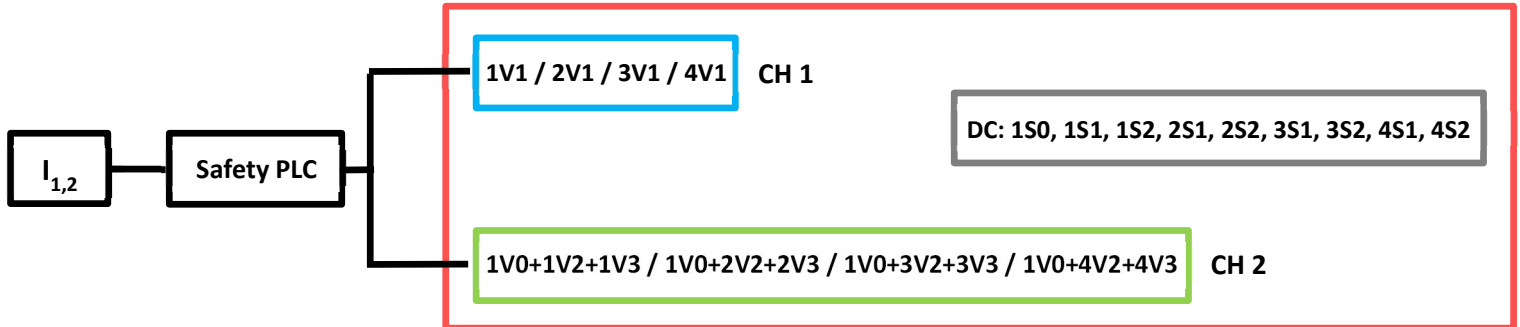

It had been identified previously that the required Category and PLr be Category 3 PLd. The following example evaluation will determine if the identified circuit along with its components will adhere to the required Category and PL rating.

Reliability Data for Pneumatic Valves: (data supplied by manufacturer)

B_{10d} of 1V1 thru 4V1 = 20,000,000 cycles (R503A2B60MA00F1)

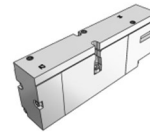

B_{10d} of 1V0 = 20,000,000 cycles (R503A2B10M11MF1)



B_{10d} of 1V2 thru 4V3 = 60,000,000 cycles (L12PA4520000000)



Machine Parameters:

Working Hours h_{op} = 16 hours

Working Days d_{op} = 240 days

Cycle Time t_{cycle} = 10 seconds

MTTFd Calculations for each CHANNEL:

(The elements in each channel are being evaluated together since their operation is simultaneous)

$$MTTF_d = \frac{B_{10d}}{0,1 \times n_{op}} \quad n_{op} = \frac{d_{op} \times h_{op} \times 3600 \text{ s/h}}{t_{cycle}}$$

CHANNEL 1 (1V1 thru 4V1):

$$n_{op} = (240 \text{ days} \times 16 \text{ hours} \times 3600 \text{ s/h}) / 10 \text{ cycle} = 1,382,400 \text{ cycles/year}$$

$$MTTF_d = 20,000,000 \text{ cycles} / 0,1 \times 1382400 \text{ cycles/year} = 145 \text{ years (value capped at 100 years)}$$

MTTFd = "HIGH"

CHANNEL 2 (1V0+1V2+1V2 thru 1V0+4V2+4V3):

$$n_{op} = (240 \text{ days} \times 16 \text{ hours} \times 3600 \text{ s/h}) / 10 \text{ cycle} = 1,382,400 \text{ cycles/year}$$

$$MTTF_{d1} = 20,000,000 \text{ cycles} / 0.1 \times 1,382,400 \text{ cycles/year} = 145 \text{ years (value capped at 100 years)}$$

$$MTTF_{d2} = 60,000,000 \text{ cycles} / 0.1 \times 1,382,400 \text{ cycles/year} = 434 \text{ years (value capped at 100 years)}$$

$$1 / MTTF_d = 1 / \sum_{1,2} MTTF_d = 108 \text{ years (value capped at 100 years)}$$

$$MTTF_d = \text{"HIGH"}$$

Taking 108 years (capped at 100), yields an $MTTF_d$ value of "HIGH".

DC (Diagnostic Coverage) / Calculations:

1V0: Pressure monitoring of the control signal for the Pilot Operated Two Position Valves: 90%

1V1 thru 4V1: Fault detection of the process: 60%

1V2 thru 8V2: Regular checking of the operation: 60%

$$DC_{avg} = \frac{\frac{DC_1}{MTTF_{d1}} + \frac{DC_2}{MTTF_{d2}} + \dots + \frac{DC_N}{MTTF_{dN}}}{\frac{1}{MTTF_{d1}} + \frac{1}{MTTF_{d2}} + \dots + \frac{1}{MTTF_{dN}}}$$

$$DC = (0.9/108) + (0.6/108) + (0.6/145) / (1/108) + (1/108) + (1/145) = 71\%$$

$$DC_{avg} = \text{Low}$$

Common Cause Failure Estimation:

Separation / Segregation:	15
Diversity:	20
Well Tried Components:	5
Environmental:	25+10
Total:	75 points (65 points required)

Mission Time Calculation:

$$T_M = \frac{B_{10d}}{n_{op}}$$

$$T_M (R503A2B60MA00F1) = 20,000,000 \text{ cycles} / 1,382,400 \text{ cycles/year} = 14.5 \text{ years}$$

$$T_M (R503A2B10M11MF1) = 20,000,000 \text{ cycles} / 1,382,400 \text{ cycles/year} = 14.5 \text{ years}$$

$$T_M (L12PA452O000000) = 60,000,000 \text{ cycles} / 1,382,400 \text{ cycles/year} = 43 \text{ years}$$

Because of Mission Time requirements (20 years) against PL adherence; 1V1 thru 4V1 and 1V0 will need to be replaced after 14.5 years.

AVENTICS™ ZONED SAFETY MANIFOLD Technical Manual

Determining Achieved PL:

The determination of category has already been satisfied based on the redundant pneumatic circuit pertaining to motion of the clamps (cylinder A1, A2, A3 and A4). Therefore, considering the DC_{avg} , the $MTTF_d$ of each channel, we can conclude adherence to Category 3 PLd for this example.

DC_{avg} = **LOW**

$MTTF_d$ = **HIGH**

Table 7 — Simplified procedure for evaluating PL achieved by SRP/CS

Category	B	1	2	2	3	3	4	Performance Level
DC_{avg}	none	none	low	medium	low	medium	high	
$MTTF_d$ of each channel								
Low	a	Not covered	a	b	b	c	Not covered	
Medium	b	Not covered	b	c	c	d	Not covered	
High	Not covered	c	c	d	d	d	e	

6.2 Example #2 Automated Insertion Tool

The example is based upon an automatic insertion tool, with manual loading and unloading of the work piece. It has been determined, based on the Risk Assessment, that the loading/unloading station requires Risk Reduction to make it safe. It has also been determined that the Safety Function requires the motion (Insertion Actuators) to release all pneumatic energy when initiated. It has also been determined that the required Category and PL_r required, based on ISO 13849-1 is, Category 3 PL_d.

The tooling in the load/unload area has three horizontally mounted insertion cylinders that each insert a roll pin in the work piece during the tool process. The insertion cylinders are represented by Actuators A1, A2 and A3 in the pneumatic circuit.

This analysis only considers the pneumatic control, in the form of a sub-system. Additional Safety-Related control components (e.g. protective devices, electrical logic elements, etc.) must be evaluated in the form of a sub-system for a complete evaluation of the Safety Function.



Safety Function: Safe Release of Air

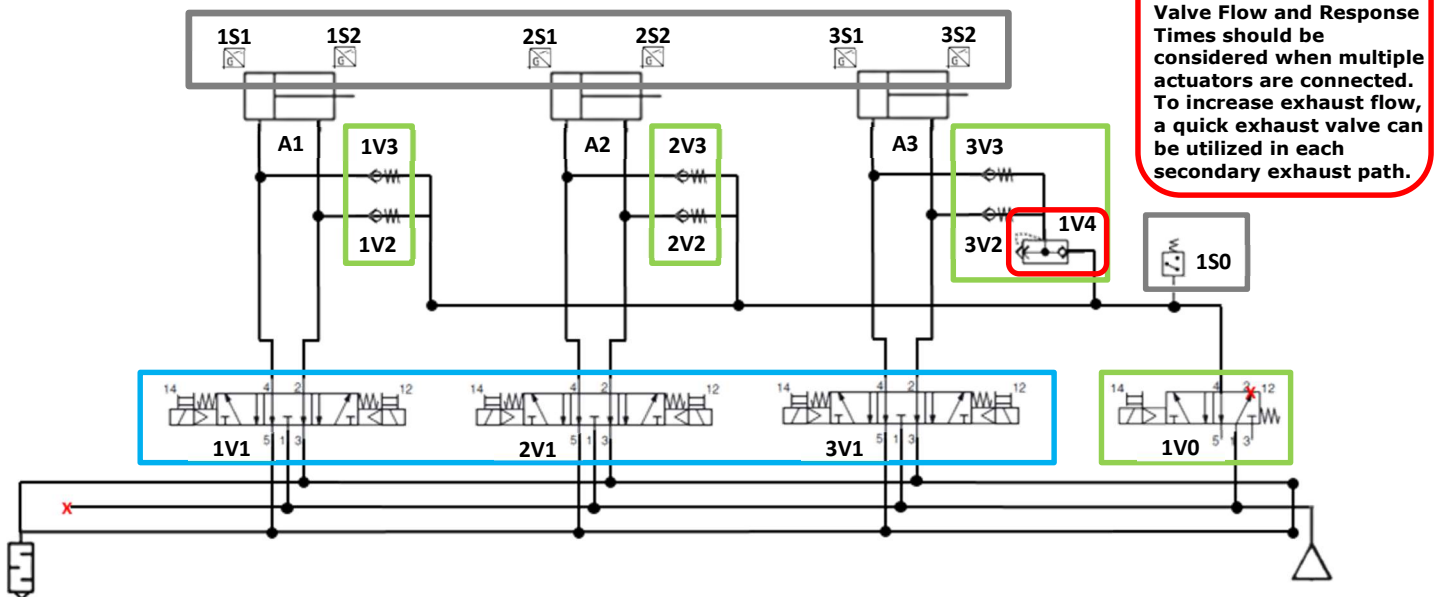

With this type of circuit, Cylinder Volume, Pilot Valve Flow and Response Times should be considered when multiple actuators are connected. To increase exhaust flow, a quick exhaust valve can be utilized in each secondary exhaust path.

The Safety Functions can be applied to each individual actuator (A1, A2 and A4); however, they can be considered a single Safety Function since they are implemented utilizing the SRP/CS. Each Actuators Safety Function is executed at the same time.

The Safety related block diagram identified below identifies the pneumatic SRP of the Zoned Safety Manifold and how they are separated into channels.

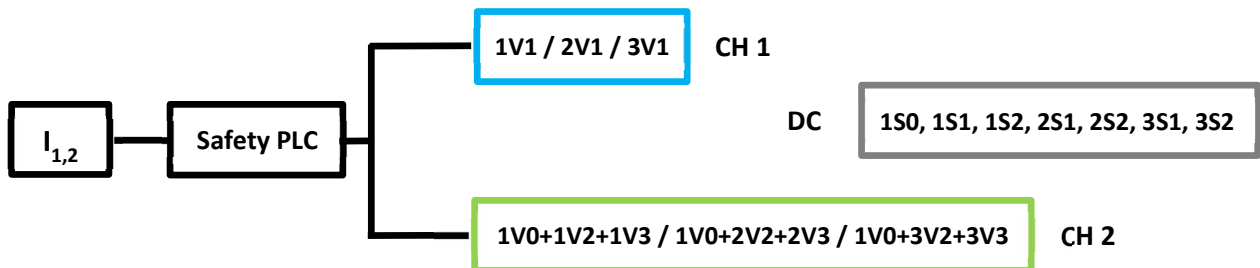

AVENTICS™ ZONED SAFETY MANIFOLD Technical Manual

The physical representation of the Zoned Safety Manifold is identified in the diagram below. Included are the required external elements (Inline Check Valves) to achieve a redundant circuit(s). The colored boxes represent the channels identified in the safety block diagram shown on the previous page.

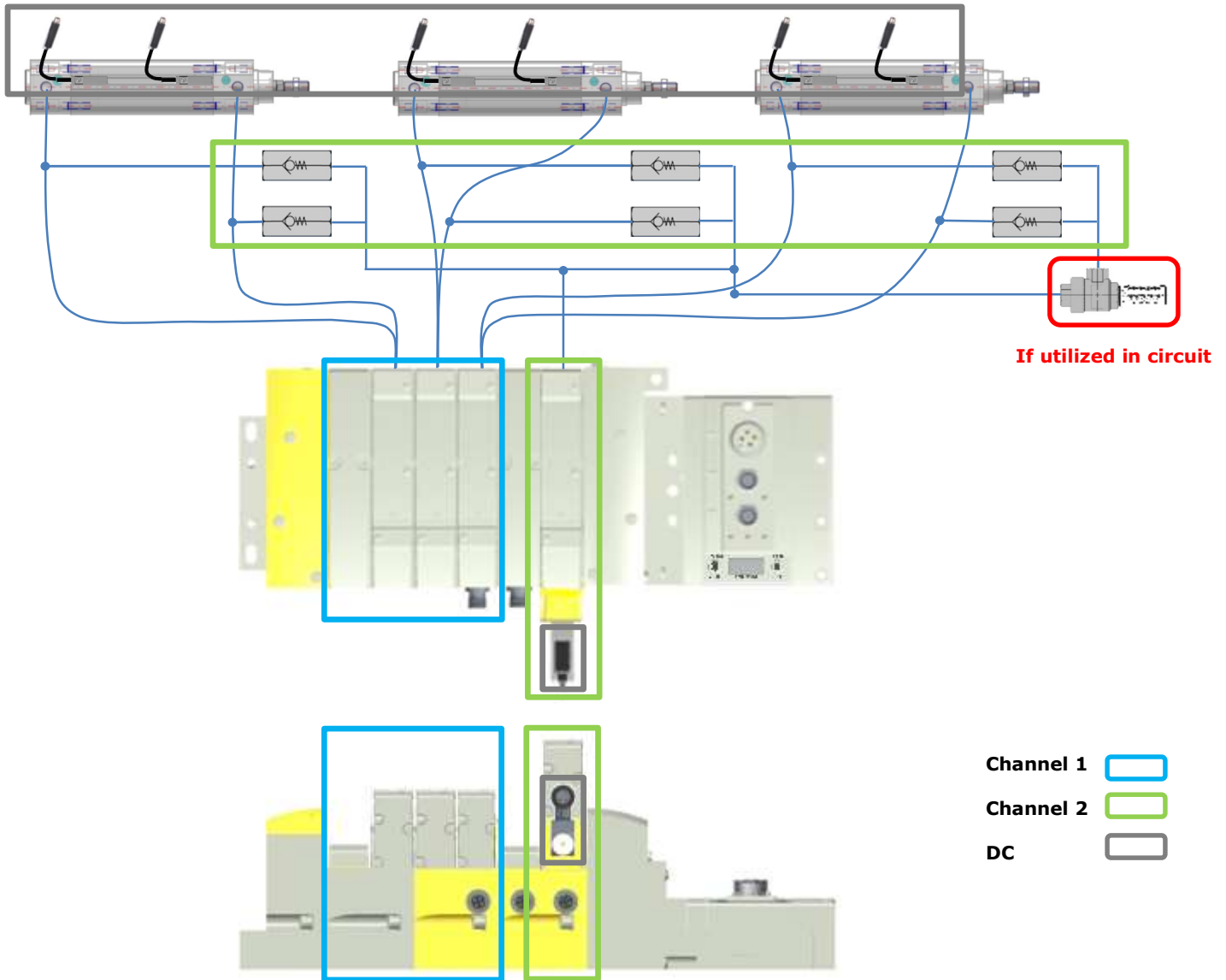

ATTENTION

When valves with Manual overrides are selected for the U-Wiring and X-Wiring manifold blocks, adequate measures must be taken to prevent any hazardous situations that may occur (e.g. use the diagnostic feedback of the DC elements as identification on a display that a valve is manually overridden).

AVENTICS™ ZONED SAFETY MANIFOLD Technical Manual

The following evaluation of MTTFd, DC, CCF, etc. for Example #2 circuit, only includes the Pneumatic portion (SRP) as a sub-system identified in the red box below. All other SRP (e.g. protective devices, electrical logic elements) must be evaluated in the form of a sub-system for a complete evaluation of the safety function.

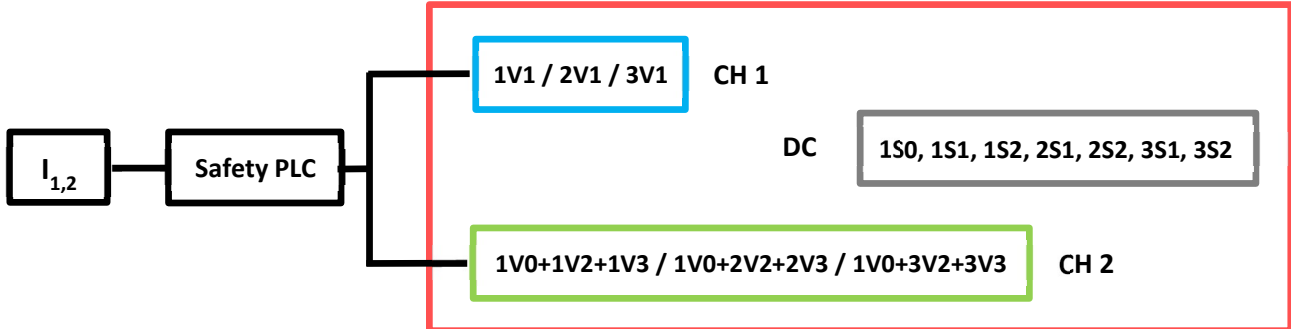

It had been identified previously that the required Category and PL_r be Category 3 PLd. The following evaluation will determine if the identified circuit along with its components will adhere to the required Category and PL.

Reliability Data for Pneumatic Valves: (data supplied by manufacturer)

B_{10d} of 1V1 thru 3V1 = 20,000,000 cycles (R503A2B50MA00F1)

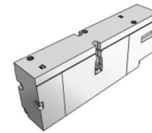

B_{10d} of 1V0 = 20,000,000 cycles (R503A2B10M11MF1)

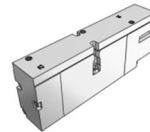

B_{10d} of 1V0 = 20,000,000 cycles (CV2FN)
(Value taken from ISO 13849-1, Table C.1)



B_{10d} of 1V0 = 20,000,000 cycles (SEV10BN)
(Value taken from ISO 13849-1, Table C.1)



If utilized in circuit

Machine Parameters:

Working Hours h_{op} = 16 hours

Working Days d_{op} = 220 days

Cycle Time t_{cycle} = 15 seconds

AVENTICS™ ZONED SAFETY MANIFOLD Technical Manual

MTTFd Calculations for each CHANNEL:

(The elements in each channel are being evaluated together since their operation is simultaneous)

$$MTTF_d = \frac{B_{10d}}{0,1 \times n_{op}} \quad n_{op} = \frac{d_{op} \times h_{op} \times 3600 \text{ s/h}}{t_{cycle}}$$

CHANNEL 1 (1V1 thru 4V1):

$$n_{op} = (220 \text{ days} \times 16 \text{ hours} \times 3600 \text{ s/h}) / 15 \text{ cycle} = 844,800 \text{ cycles/year}$$

$$MTTF_d = 20,000,000 \text{ cycles} / 0.1 \times 844,800 \text{ cycles/year} = 237 \text{ years (value capped at 100 years)}$$

$$MTTF_d = \text{"HIGH"}$$

CHANNEL 2 (1V0+1V2+1V3 thru 1V0+3V2+3V3):

$$n_{op} = (220 \text{ days} \times 16 \text{ hours} \times 3600 \text{ s/h}) / 15 \text{ cycle} = 844,800 \text{ cycles/year}$$

$$MTTF_{d1} = 20,000,000 \text{ cycles} / 0.1 \times 844,800 \text{ cycles/year} = 237 \text{ years (value capped at 100 years)}$$

$$MTTF_{d2} = 20,000,000 \text{ cycles} / 0.1 \times 844,800 \text{ cycles/year} = 237 \text{ years (value capped at 100 years)}$$

$$MTTF_{d3} = 20,000,000 \text{ cycles} / 0.1 \times 844,800 \text{ cycles/year} = 237 \text{ years (value capped at 100 years)}$$

$$MTTF_{d4} = 20,000,000 \text{ cycles} / 0.1 \times 844,800 \text{ cycles/year} = 237 \text{ years (value capped at 100 years)}$$

If utilized in circuit

$$1 / MTTF_d = 1 / \Sigma_{1,2,3,4} (MTTF_d) = 79 \text{ years (value capped at 100 years)}$$

$$1 / MTTF_d = 1 / \Sigma_{1,2,3,4} (MTTF_d) = 59 \text{ years (value capped at 100 years)}$$

If utilized in circuit

$$MTTF_d = \text{"HIGH"} \text{ with or without Quick Exhaust Valve SEVxxBN}$$

DC (Diagnostic Coverage) / Calculations:

1V0: Pressure monitoring of the control signal for the Inline Check Valves: 90%

1V1 thru 3V1: Fault detection of the process: 60%

$$DC_{avg} = \frac{\frac{DC_1}{MTTF_{d1}} + \frac{DC_2}{MTTF_{d2}} + \dots + \frac{DC_N}{MTTF_{dN}}}{\frac{1}{MTTF_{d1}} + \frac{1}{MTTF_{d2}} + \dots + \frac{1}{MTTF_{dN}}}$$

$$DC = (0.9/237) + (0.6/237) / (1/237) + (1/237) = 75\%$$

$$DC_{avg} = \text{Low}$$

Common Cause Failure Estimation:

Separation / Segregation:	15
Diversity:	20
Well Tried Components:	5
Environmental:	25+10
Total:	75 points (65 points required)

AVENTICS™ ZONED SAFETY MANIFOLD Technical Manual

Mission Time Calculation:

$$T_M = \frac{B_{10d}}{n_{op}}$$

$$T_M (R503A2B50MA00F1) = 20,000,000 \text{ cycles} / 844,800 \text{ cycles/year} = 23.6 \text{ years}$$

$$T_M (R503A2B10M11MF1) = 20,000,000 \text{ cycles} / 844,800 \text{ cycles/year} = 23.6 \text{ years}$$

$$T_M (CV2FN) = 20,000,000 \text{ cycles} / 844,800 \text{ cycles/year} = 23.6 \text{ years}$$

$$T_M (SEV10BN) = 20,000,000 \text{ cycles} / 844,800 \text{ cycles/year} = 23.6 \text{ years}$$

If utilized in circuit

A minimum of 20 years for Mission Time is met for this system.

Determining Achieved PL:

The determination of category has already been satisfied based on the redundant pneumatic circuit pertaining to motion of the clamps (cylinder A1, A2, A3 and A4). Therefore, considering the DC_{avg} , the $MTTF_d$ of each channel, we can conclude adherence to Category 3 PLd for this example.

$DC_{avg} =$ **LOW**

$MTTF_d =$ **HIGH**

Table 7 — Simplified procedure for evaluating PL achieved by SRP/CS

Category	B	1	2	2	3	3	4	Performance Level
DC_{avg}	none	none	low	medium	low	medium	high	
$MTTF_d$ of each channel								
Low	a	Not covered	a	b	b	c	Not covered	
Medium	b	Not covered	b	c	c	d	Not covered	
High	Not covered	c	c	d	d	d	e	

6.3 Example #3 Clamping Weld Fixture

The example is based upon an automated weld fixture, with manual loading and unloading of the work piece. It has been determined, based on the Risk Assessment, that the loading/unloading station requires Risk Reduction to make it safe. It has also been determined that the Safety Function requires the motion (Clamping Cylinders) to move to a safe position. It has also been determined that the required Category and PL_r required, based on ISO 13849-1 is, Category 3 PL_d.

The tooling in the load/unload area has three pneumatic clamp cylinders that each clamp an area of the inserted sheet metal during the weld process. The clamping cylinders are represented by Actuators A1, A2 and A3 in the pneumatic circuit.

This analysis only considers the pneumatic control, in the form of a sub-system. Additional Safety-Related control components (e.g. protective devices, electrical logic elements, etc.) must be evaluated in the form of a sub-system for a complete evaluation of the Safety Function.

Safety Function: Safe Return of Motion

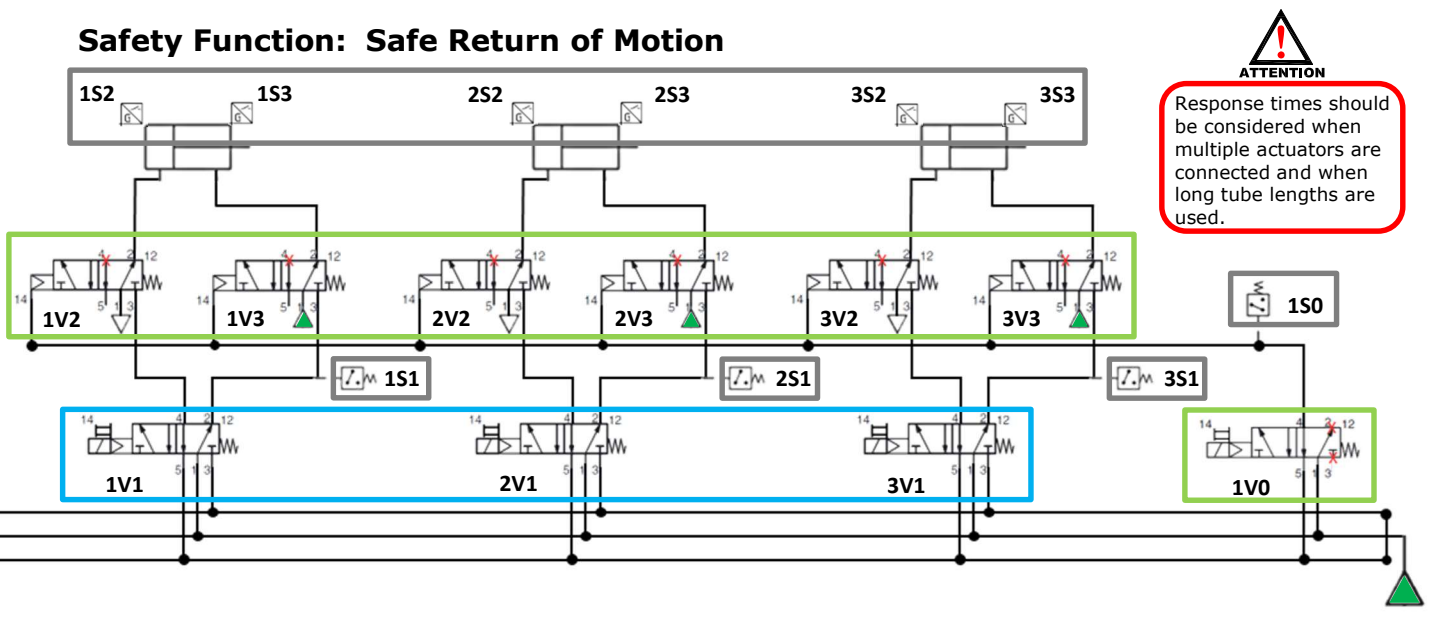

The Safety Functions can be applied to each individual actuator (A1, A2 and A4); however, they can be considered a single Safety Function since they are implemented utilizing the SRP/CS. Each Actuators Safety Function is executed at the same time.

The Safety related block diagram identified below identifies the pneumatic SRP of the Zoned Safety Manifold and how they are separated into channels.

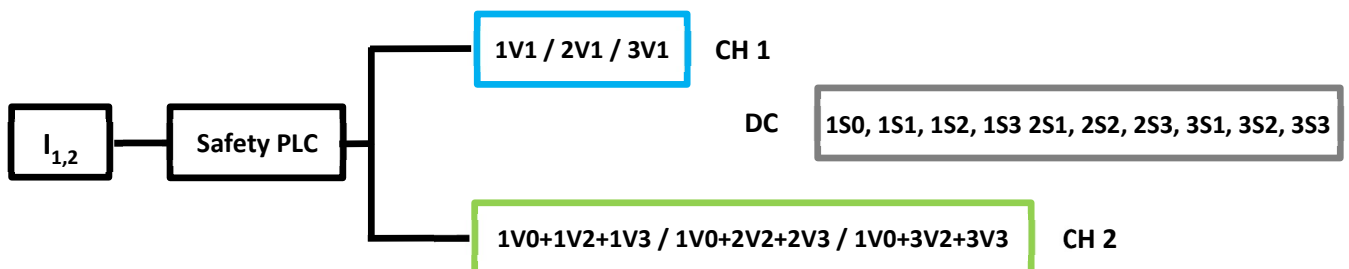

AVENTICS™ ZONED SAFETY MANIFOLD Technical Manual

The physical representation of the Zoned Safety Manifold is identified in the diagram below. Included are the required external elements (Pilot Actuated & Solenoid Pilot Actuated Valves) to achieve a redundant circuit(s). The colored boxes represent the channels identified in the safety block diagram shown on the previous page.

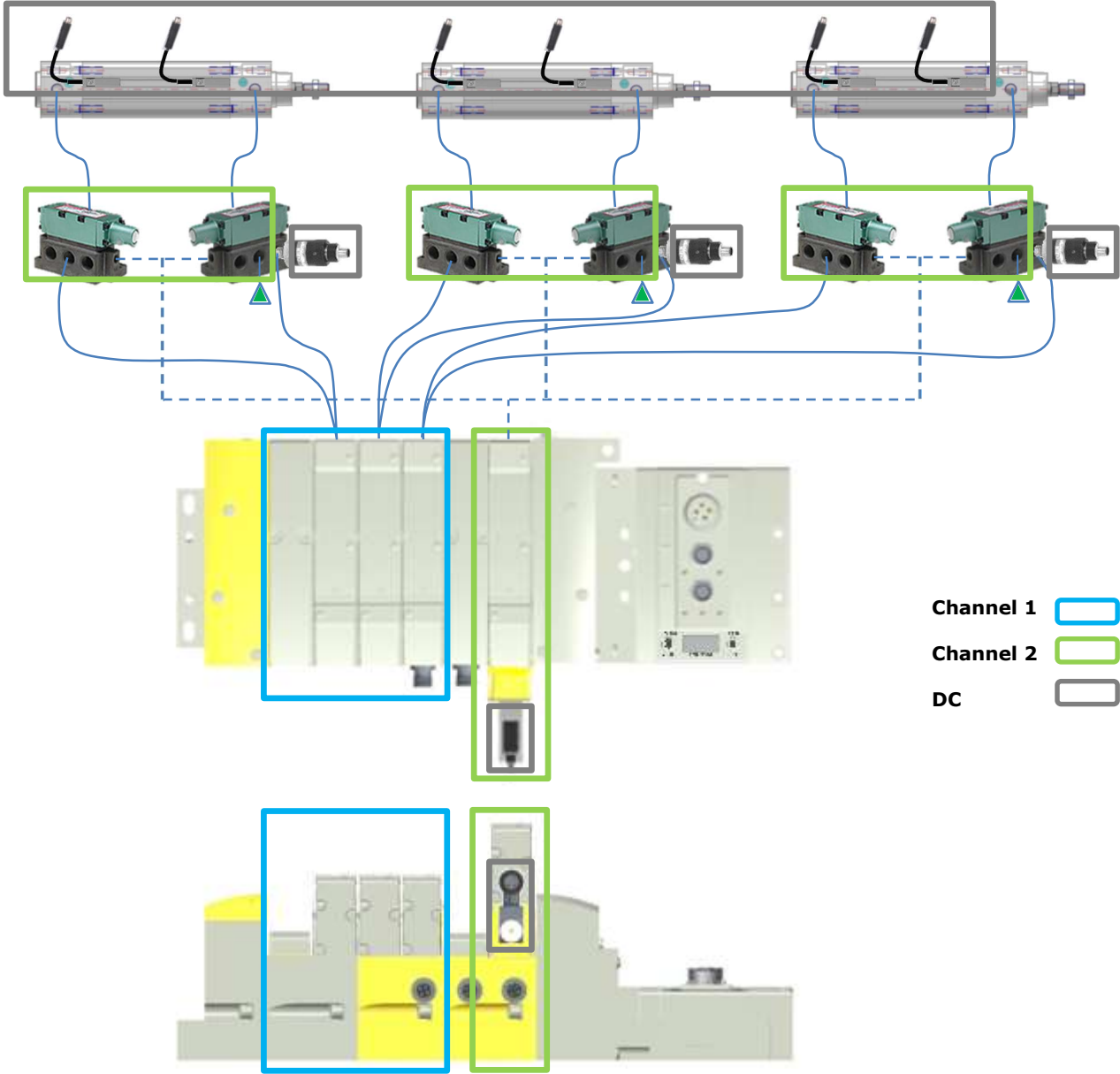

When valves with Manual overrides are selected for the U-Wiring and X-Wiring manifold blocks, adequate measures must be taken to prevent any hazardous situations that may occur (e.g. use the diagnostic feedback of the DC elements as identification on a display that a valve is manually overridden).

AVENTICS™ ZONED SAFETY MANIFOLD Technical Manual

The following evaluation of MTTFd, DC, CCF, etc. for Example #3 circuit, only includes the Pneumatic portion (SRP) as a sub-system identified in the red box below. All other SRP (e.g. protective devices, electrical logic elements) must be evaluated in the form of a sub-system for a complete evaluation of the safety function.

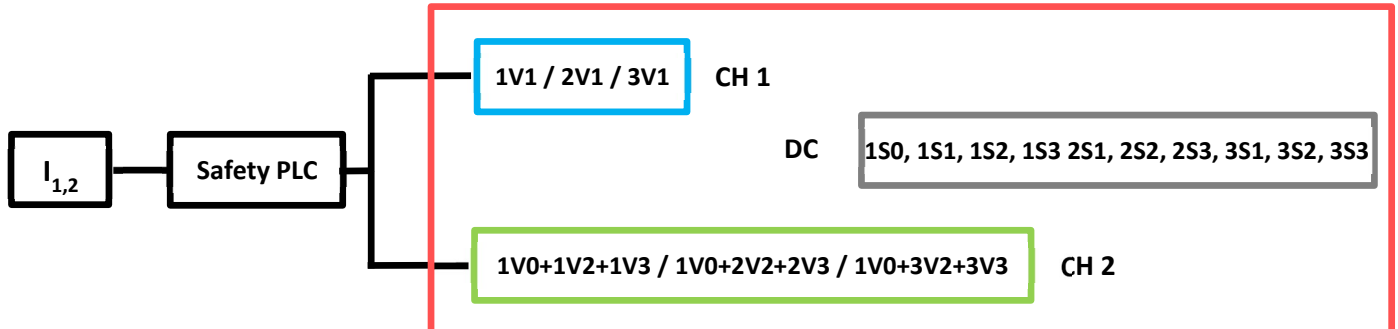

It had been identified previously that the required Category and PL_r be Category 3 PL_d. The following evaluation will determine if the identified circuit along with its components will adhere to the required Category and PL.

Reliability Data for Pneumatic Valves: (data supplied by manufacturer)

B_{10d} of 1V1 thru 3V1 = 20,000,000 cycles (R503A2B40MA00F1)

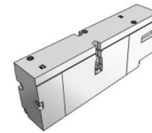

B_{10d} of 1V0 = 20,000,000 cycles (R503A2B10M11MF1)

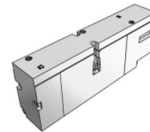

B_{10d} of 1V2, 2V2, 3V2 = 20,000,000 cycles (153PA4410000000)
(Value taken from ISO 13849-1, Table C.1)



B_{10d} of 1V3, 2V3, 3V3 = 20,000,000 cycles (153PA4410000000)
(Value taken from ISO 13849-1, Table C.1)



Machine Parameters:

Working Hours h_{op} = 8 hours

Working days d_{op} = 220 days

Cycle Time t_{cycle} = 20 seconds

MTTFd Calculations for each CHANNEL:

(The elements in each channel are being evaluated together since their operation is simultaneous)

$$MTTF_d = \frac{B_{10d}}{0,1 \times n_{op}} \quad n_{op} = \frac{d_{op} \times h_{op} \times 3600 \text{ s/h}}{t_{cycle}}$$

AVENTICS™ ZONED SAFETY MANIFOLD Technical Manual

CHANNEL 1 (1V1 thru 3V1):

$$n_{op} = (220 \text{ days} \times 8 \text{ hours} \times 3600 \text{ s/h}) / 20 \text{ cycle} = 316,800 \text{ cycles/year}$$

$$MTTF_d = 20,000,000 \text{ cycles} / 0.1 \times 316,800 \text{ cycles/year} = 631 \text{ years (value capped at 100 years)}$$

$$MTTF_d = \text{"HIGH"}$$

CHANNEL 2 (1V0+1V2+1V3 thru 1V0+3V2+3V3):

$$n_{op} = (220 \text{ days} \times 16 \text{ hours} \times 3600 \text{ s/h}) / 15 \text{ cycle} = 844,800 \text{ cycles/year}$$

$$MTTF_{d1} = 20,000,000 \text{ cycles} / 0.1 \times 844,800 \text{ cycles/year} = 237 \text{ years (value capped at 100 years)}$$

$$MTTF_{d2} = 20,000,000 \text{ cycles} / 0.1 \times 844,800 \text{ cycles/year} = 237 \text{ years (value capped at 100 years)}$$

$$1 / MTTF_d = 1 / \Sigma_{1,2,3} (MTTF_d) = 118 \text{ years}$$

$$MTTF_d = \text{"HIGH"}$$

Taking 79 years, yields an $MTTF_d$ value of "HIGH".

DC (Diagnostic Coverage) / Calculations:

1V1, 2V1 and 3V1: Pressure monitoring by 1S1, 2S1 and 3S1: 90%

1V0, 1V2, 1V3, 2V2, 2V3, 3V2 and 3V3: Position monitoring by 1S2, 2S2 and 3S2: 90%

$$DC_{avg} = \frac{\frac{DC_1}{MTTF_{d1}} + \frac{DC_2}{MTTF_{d2}} + \dots + \frac{DC_N}{MTTF_{dN}}}{\frac{1}{MTTF_{d1}} + \frac{1}{MTTF_{d2}} + \dots + \frac{1}{MTTF_{dN}}}$$

$$DC = (0.9/631) + (0.9/237) + (0.9/237) + (0.9/237) / ((1/631) + (1/237) + (1/237) + (1/237)) = 90\%$$

$$DC_{avg} = \text{MEDIUM}$$

Common Cause Failure Estimation:

Separation / Segregation:	15
Diversity:	20
Well Tried Components:	5
Environmental:	25+10
Total:	75 points (65 points required)

Mission Time Calculation:

AVENTICS™ ZONED SAFETY MANIFOLD Technical Manual

$$T_M = \frac{B_{10d}}{n_{op}}$$

$$T_M (R503A2B40MA00F1) = 20,000,000 \text{ cycles} / 316,800 \text{ cycles/year} = 63.1 \text{ years}$$

$$T_M (R503A2B40MA00F1) = 20,000,000 \text{ cycles} / 316,800 \text{ cycles/year} = 63.1 \text{ years}$$

$$T_M (153PA441O000000) = 20,000,000 \text{ cycles} / 316,800 \text{ cycles/year} = 63.1 \text{ years}$$

$$T_M (153PA441O000000) = 20,000,000 \text{ cycles} / 316,800 \text{ cycles/year} = 63.1 \text{ years}$$

A minimum of 20 years for Mission Time is met for this system.

Determining Achieved PL:

The determination of category has already been satisfied based on the redundant pneumatic circuit pertaining to motion of the clamps (cylinder A1, A2, A3 and A4). Therefore, considering the DC_{avg} , the $MTTF_d$ of each channel, we can conclude adherence to Category 3 PLd for this example.

$DC_{avg} =$ **MEDIUM**

$MTTF_d =$ **HIGH**

Table 7 — Simplified procedure for evaluating PL achieved by SRP/CS

Category	B	1	2	2	3	3	4
DC_{avg}	none	none	low	medium	low	medium	high
$MTTF_d$ of each channel							
Low	a	Not covered	a	b	b	c	Not covered
Medium	b	Not covered	b	c	c	d	Not covered
High	Not covered	c	c	d	d	d	e

Performance Level

7. Appendix

7.1 System Specifications

Electrical	
Supply Voltage	Valves (501, 502, 503): 24 VDC ± 10% Node: 24 VDC ± 10%
Current	Total current on the Power Connector ("Valves" and "Node" Pins) must not exceed 4 Amps.
Reverse Polarity	Reverse polarity protection is provided on both Node and Valve power.
Recommended External Fuse	External fuses should be chosen depending upon manifold configuration. Please refer to power consumption chart in the specific Technical Manual of the used protocol, for additional fuse sizing information.
Spike Protection	Output spike protection is internally provided for valve and discrete outputs. Additionally, all 500 Series valves have integrated spike suppression.
Valve Solenoid Coil Output Drivers	Maximum 0.5 Amps per output. All output points are short circuit protected and have internal spike protection.
Operating Temperature for Electronic Components	-10 to 115°F (-23 to 46°C)

7.2 Factory Default Settings

Please refer to the Technical Manual related to the protocol used. The factory defaults identified below are specific to the Zone Safety Manifold operability.

FACTORY DEFAULT SETTINGS	
<i>Description</i>	<i>Default</i>
Number of Safety Zones	Setting based on the number of "Zones" (number of "X" wiring manifolds. See Section 4.0 for reference to "X" wiring manifolds).

7.3 Troubleshooting/Error Messaging

<i>Symptom</i>	<i>Possible Cause</i>	<i>Solution</i>
Safety Zone Mismatch	Zone setting Parameter of node does not match physical manifold.	Adjust Parameter to match; see section 3.3

See appropriate Technical Manual for protocol specific issue(s). Technical Manual reference can be identified in Section 3.1, Page 10.

AVENTICS™ ZONED SAFETY MANIFOLD Technical Manual

7.4 Glossary of Terms

The following is a list and description of common terms and symbols used throughout this document:

Term	Description
A, b, c, d, e	Performance Level indication
B, 1, 2, 3, 4	Category indication
B _{10d}	Number of Cycles that 10% of the components fail dangerously
CCF	Common cause failure
DC	Diagnostic coverage
DC _{avg}	Average diagnostic coverage
d _{op}	Mean operation, in days per year
h _{op}	Mean operation, in hours per day
MTTF _d	Mean time to dangerous failure
n _{op}	Number of cycles/year of a SRP, based on d _{op} , h _{op} and t _{cycles}
PL	Performance Level
PL _r	Performance Level required
Risk assessment	Overall process that includes the risk analysis and risk evaluation
Risk analysis	A combination of the specified limits of the machine, identified hazards and risk estimation
Risk evaluation	Determination, based on the risk analysis, of whether the risk reduction objectives have been reached
Safety function	Function of the machine whose failure can result in an immediate increase of the risk(s)
SRP/CS	Safety Related Parts of a Control System
t _{cycle}	The mean time between the beginning of two successive cycles of the component (e.g. switching of a valve) in seconds per cycle
T _M	Period of time covering the intended use of an SRP/CS
501, 502, 503	Valve platforms that support Zoned Safety

7.5 Technical Support

For technical support, contact your local AVENTICS distributor. If further information is required, please call ASCO Technical Support Department at (248) 596-3337 or email ASCONumatics.TechSupport@emerson.com.

Issues relating to network setup, PLC programming, sequencing, software related functions, etc. should be handled with the appropriate product vendor.

Information on device files, technical manuals, local distributors, and other AVENTICS products and support issues can be found on the ASCO website at www.asco.com.