

REVISION TABLE			
REVISION	ECO NO.	APP'D	DATE
AA		A.L	05/24/23
DESCRIPTION			
INITIAL RELEASE			

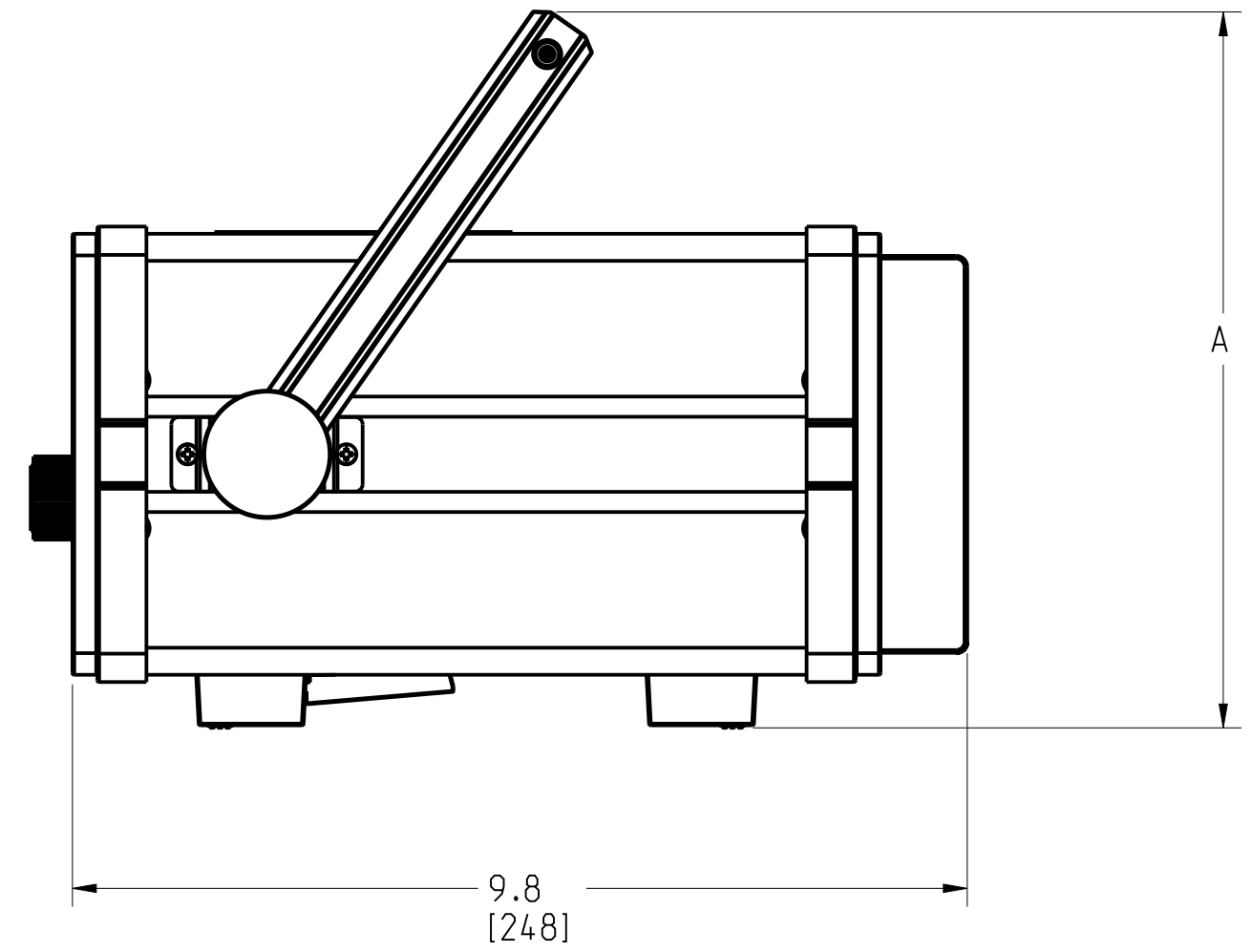

A. Maximum 7.87inch (200mm)

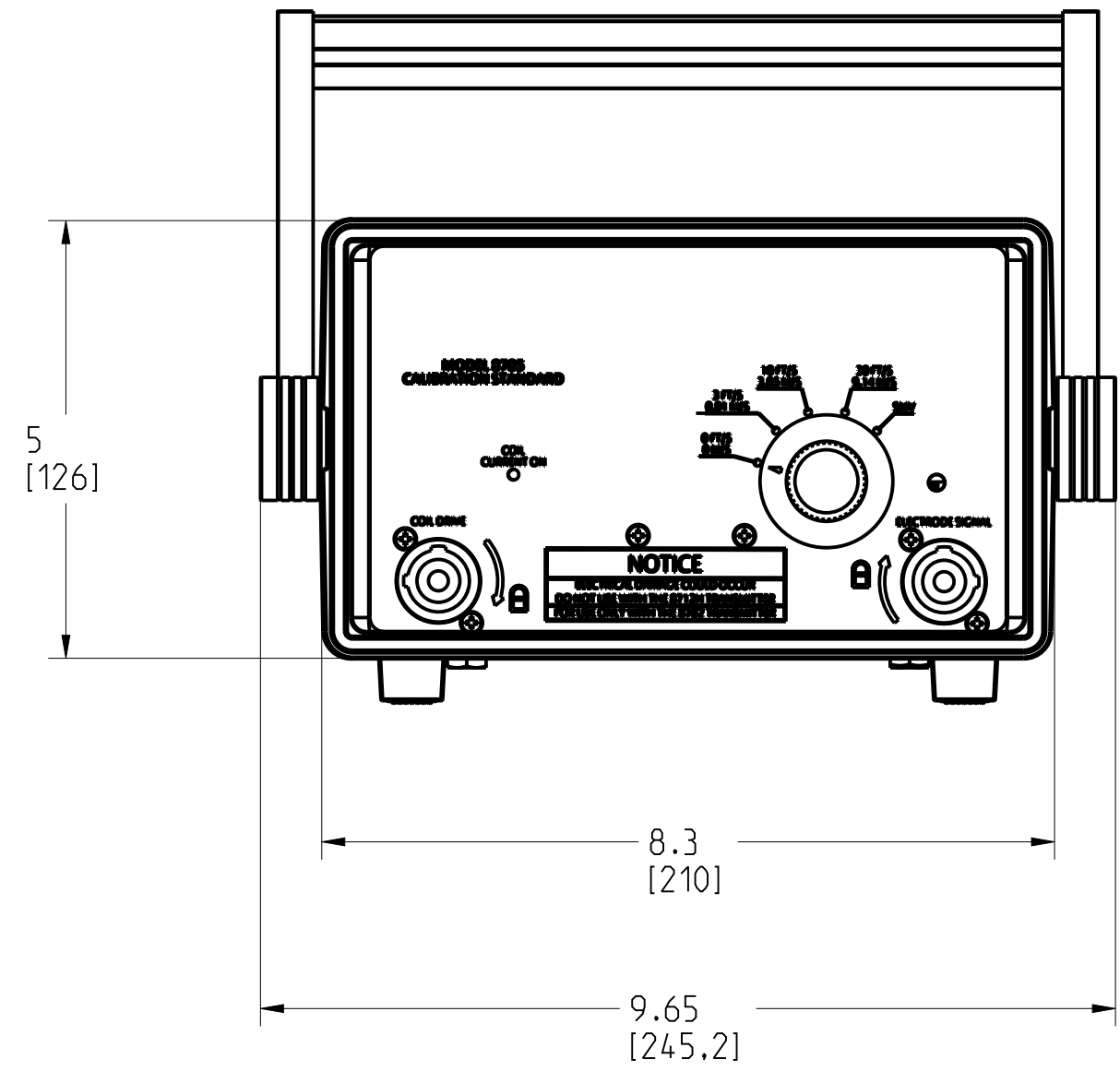
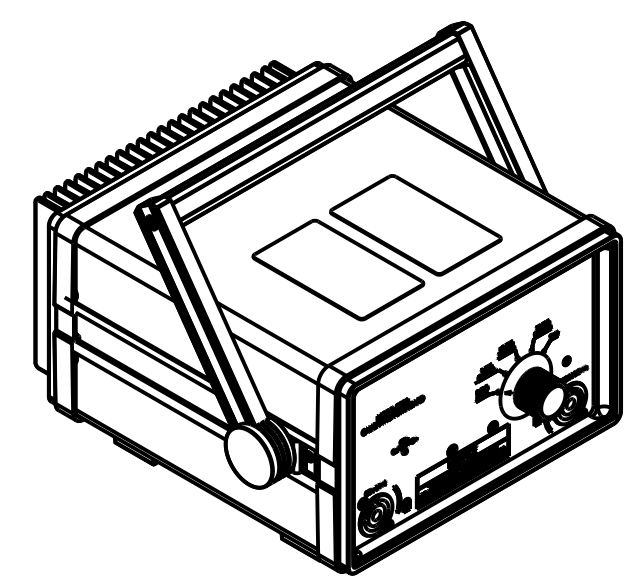

DRAWING NO. 08785-1124

3. CONSULT PRODUCT MANUAL FOR DETAILED INFORMATION ON INSTALLATION, OPERATION OR MAINTENANCE. FAILURE TO DO SO COULD RESULT IN INJURY OR DAMAGE.
2. UPPER DIMENSIONS ARE IN INCHES. DIMENSIONS SHOWN IN BRACKETS ARE IN MILLIMETERS.
1. ROSEMOUNT CERTIFIES THAT THIS DRAWING IS IN ACCORDANCE WITH ROSEMOUNT ENGINEERING SPECIFICATIONS AND ACCURATELY REPRESENTS THE EQUIPMENT FURNISHED.

CONFIDENTIAL AND PROPRIETARY INFORMATION IS CONTAINED HEREIN AND MUST BE HANDLED ACCORDINGLY.		SURFACE FINISH UNLESS OTHERWISE SPECIFIED		125	3RD ANGLE		SIZE C	SCALE 1/4	REV AA
UNLESS OTHERWISE SPECIFIED DIMENSIONS IN INCHES (mm). REMOVE ALL BURRS AND SHARP EDGES.		EMERSON ROSEMOUNT							
-DEC TOLERANCES-		TITLE							
.X ± .1 [2.5]	.XX ± .02 [0.5]	DIMENSIONAL DRAWING							
.XXX ± .005 [0.25]	FRACTIONS ± 1/32	08785 CALIBRATION							
ANGLES ± 2°	APP'D	DANDA.C	5/24/23	DRAWING NO.		08785-1124			
DO NOT SCALE PRINT	CAD MAINTAINED. (PRO/ε)	PRODUCT CODE	DOC TYPE	SHEET 1 OF 1					

FORM REV AD