

Technical Note

00840-0100-4664, Rev BB

March 2012

Ground/Wiring Fault Detection

Ground and Wiring Fault Detection Field Guide

WHY USE GROUND AND WIRING FAULT DETECTION DIAGNOSTIC?

The Ground/Wiring Fault Detection diagnostic provides a means of verifying installations are done correctly. If the installation is not wired or grounded properly, this diagnostic will activate and deliver a PlantWeb alert. This diagnostic can also detect if the grounding is lost over time due to corrosion or another root cause. For more information on the functionality of this diagnostic, see page 2.

How to Set-up

1. **Confirm that the Ground/Wiring Fault diagnostic is available (option code DA1/D01) and enabled.** For more information on ordering this option, see page 3.
2. **Verify that transmitter is earth grounded and that sensor is full.** For more information on proper grounding, see page 2.
3. **Read value of Line Noise parameter.** This value is the measure of signal strength at 50 and 60 Hz. The transmitter specifically looks at the signal amplitude at 50 Hz and 60 Hz because they are common AC cycle frequencies found throughout the World. If the Line Noise value exceeds 5 mV, then the Ground/Wiring Fault diagnostic alert will activate. For more information on the Line Noise parameter, see page 3.
4. **If the transmitter detects high levels of 50/60 Hz noise caused by improper wiring or poor process grounding,** see page 3 for troubleshooting procedures.

Field Comm. Fast Keys	1, 2, 1, 1, Ground/Wiring
LOI Menu	Diagnostics, Diag Controls, Ground/Wiring
AMS	Diagnostics
Enhanced DD	Configure, Manual Setup, Diagnostics, Enable Diagnostics

Field Comm. Fast Keys	1, 2, 4, 3
LOI Menu	Diagnostics, Variables, Line Noise
AMS	Diagnostics
Enhanced DD	Service Tools, Variables, Process Diagnostics, Line Noise

ROSEMOUNT®

www.rosemount.com

EMERSON™
Process Management

Ground/Wiring Fault Detection

GROUND AND WIRING FAULT DETECTION

The Ground/Wiring Fault Detection diagnostic provides a means of verifying installations are done correctly. If the installation is not wired or grounded properly, this diagnostic will activate and deliver a PlantWeb alert. This diagnostic can also detect if the grounding is lost over time due to corrosion or another root cause.

THE IMPORTANCE OF PROPER GROUNDING

Improper grounding and wiring is the number one cause of magnetic flowmeter issues. This is primarily an issue that occurs in new installations where the magnetic flowmeter is not properly referenced to the process fluid. This allows electrical noise to be picked up by the electrodes and consequently affects the signal to noise ratio and the stability of the transmitter output. The magnetic flowmeter also needs to have a path to earth ground. Typically this is done through process piping.

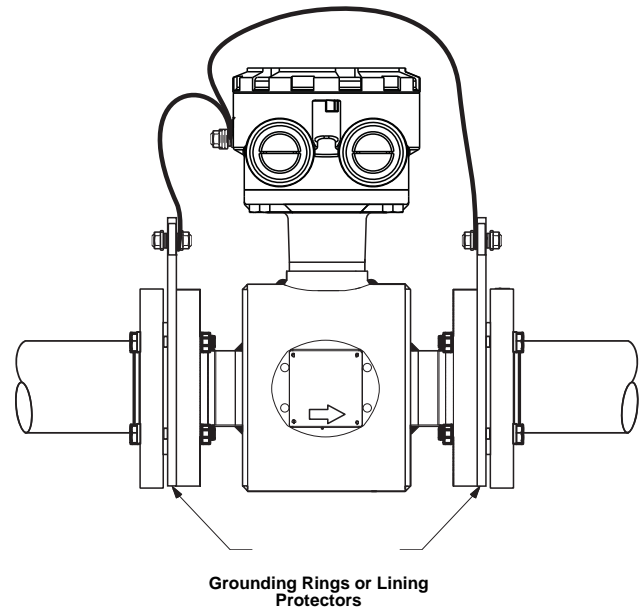

Ground Option	Conductivity Requirement	Process Piping Material			Relative Price	Notes
		Conductive (Metal Pipe)	Non-conductive (Plastic, etc)	Conductive Lined		
Grounding Straps	5 μ S	✓	NA	NA	No Charge	Provided with every E-series Mag Tube
Grounding Electrode	100 μ S	✓	✓	✓	Low	Least Expensive option, provides convenient grounding for non-conductive and lined pipe applications
Ground Rings	5 μ S	✓	✓	✓	High	Provides best ground for non-conductive and lined pipe applications
Lining Protectors	5 μ S	✓	✓	✓	Highest	Most expensive, protects leading edge from wear in tough slurry applications. Provides same grounding protection as ground rings.

Technical Note

00840-0100-4664, Rev BB

March 2012

Ground/Wiring Fault Detection

With proper grounding, the transmitter has a reference to any stray electrical signals from motors, generators, or other electrical equipment that are present in the process and can filter them out.

GROUND AND WIRING FAULT DETECTION FUNCTIONALITY

The transmitter continuously monitors signal amplitudes over a wide range of frequencies. For the Ground/Wiring Fault diagnostic, the transmitter specifically looks at the signal amplitude at frequencies of 50 Hz and 60 Hz which are the common AC cycle frequencies found throughout the world. If the amplitude of the signal at either of these frequencies exceeds 5 mV, that is an indication that there is a ground or wiring issue and that stray electrical signals are getting into the transmitter. The diagnostic alert will activate indicating that the ground and wiring of the installation should be carefully reviewed.

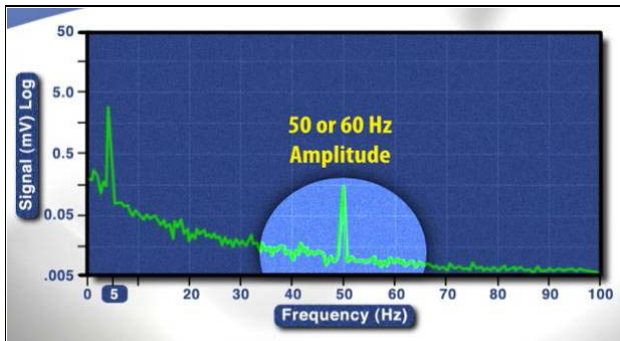

ENABLING THE GROUND AND WIRING DIAGNOSTIC

The Ground/Wiring Fault diagnostic can be turned on or off using AMS Suite: Intelligent Device Manager, a Field Communicator, or the Local Operator Interface (LOI) as required by the application. If the Advanced Diagnostics Suite 1 (DA1/D01 option) was ordered, then the Ground/Wiring Fault diagnostic will be turned on. If DA1/D01 was not ordered or licensed, this diagnostic is not available. However, the DA1/D01 option is available for purchase after the meter is installed. Contact your local sales representative to trial or order this option in the field.

UNDERSTANDING THE GROUND AND WIRING FAULT DIAGNOSTIC PARAMETERS

The Ground/Wiring Fault diagnostic has one read-only parameter. It does not have any configurable parameters.

Line Noise

This is the current amplitude of the Line Noise. This is a read-only value. This number is a measure of the signal strength at 50/60 Hz. If the Line Noise value exceeds 5 mV, then the Ground/Wiring Fault diagnostic alert will activate.

TROUBLESHOOTING THE GROUND AND WIRING FAULT DIAGNOSTIC

The transmitter detected high levels of 50/60 Hz noise caused by improper wiring or poor process grounding.

1. Verify that the transmitter is earth grounded.
2. Connect ground rings, grounding electrode, lining protector, or grounding straps. Use the table below to determine which process grounding option to follow for proper installation. The sensor case should be earth grounded in accordance with national and local electrical codes. Failure to do so may impair the protection provided by the equipment.

Process Grounding Options				
Type of Pipe	Grounding Straps	Grounding Rings	Grounding Electrode	Lining Protectors
Conductive Unlined Pipe	See Figure 1	Not Required	Not Required	See Figure 2
Conductive Lined Pipe	Insufficient Grounding	See Figure 2	See Figure 1	See Figure 2
Non-Conductive Pipe	Insufficient Grounding	See Figure 3	See Figure 4	See Figure 3

Figure 1. Grounding Straps or Grounding Electrode in Lined Pipe

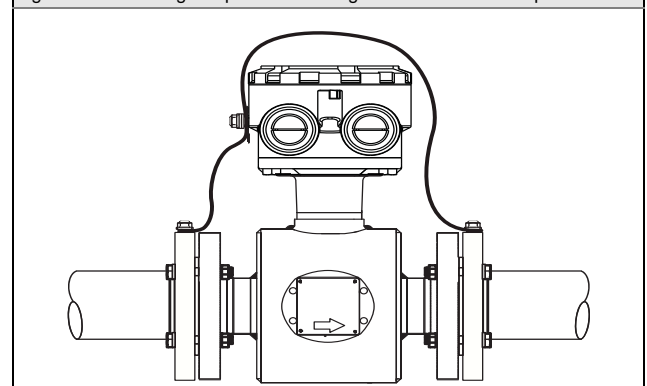

Ground/Wiring Fault Detection

Figure 2. Grounding with Grounding Rings or Lining Protectors

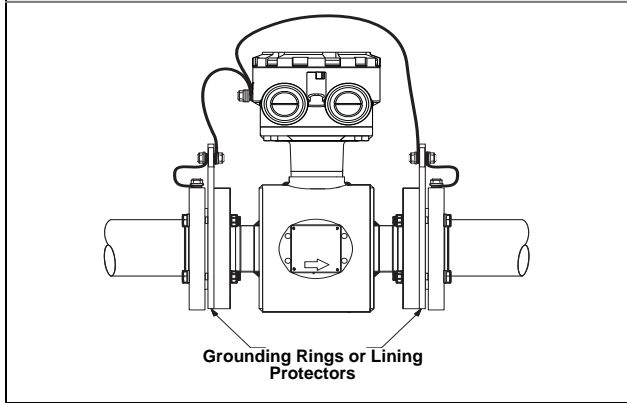

Figure 3. Grounding with Grounding Rings or Lining Protectors

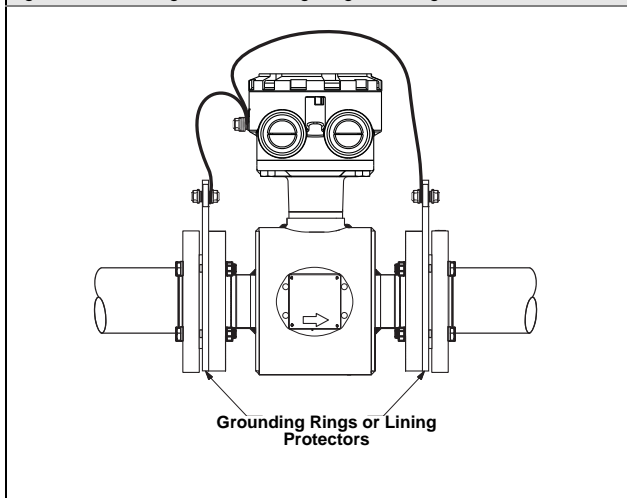
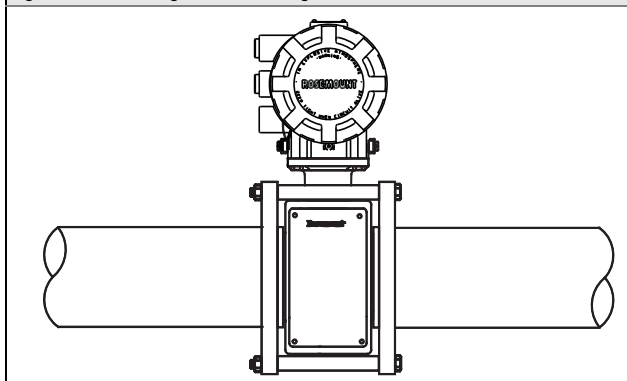

Figure 4. Grounding with Grounding Electrode



3. Verify sensor is full.
4. Verify wiring between sensor and transmitter is prepared properly. Shielding should be stripped back less than 1 in. (25 mm).
5. Use separate shielded twisted pairs for wiring between flowtube sensor and transmitter. See cable requirements in table below.

Description	Units	Part Number
Signal Cable (20 AWG) Belden 8762, Alpha 2411 equivalent	ft m	08712-0061-0001 08712-0061-2003
Coil Drive Cable (14 AWG) Belden 8720, Alpha 2442 equivalent	ft m	08712-0060-0001 08712-0060-2003
Combination Signal and Coil Drive Cable (18 and 20 AWG) ⁽¹⁾	ft m	08712-0752-0001 08712-0752-2003

(1) *Combination signal and coil drive cable is not recommended for high-signal magmeter system. For remote mount installations, combination signal and coil drive cable should be limited to less than 330 ft. (100 m).*

6. Properly connect the wiring between the flowtube sensor and the transmitter. The coil drive cable should be wired to terminals 1, 2, and 3 (ground). (See Table 1)

The signal cables should be wired to terminals 17 (ground reference), 18, and 19. (See Table 2)

Table 1. Individual Coil and Signal Cables

Transmitter Terminal	Sensor Terminal	Wire Gauge	Wire Color
1	1	14	Clear
2	2	14	Black
3 or Ground	3 or Ground	14	Shield
17	17	20	Shield
18	18	20	Black
19	19	20	Clear

Table 2. Combination Coil and Signal Cable

Transmitter Terminal	Sensor Terminal	Wire Gauge	Wire Color
1	1	18	Red
2	2	18	Green
3 or Ground	3 or Ground	18	Shield
17	17	20	Shield
18	18	20	Black
19	19	20	White

Ground/Wiring Fault Detection

Technical Note
00840-0100-4664, Rev BB
March 2012

*The Emerson logo is a trade mark and service mark of Emerson Electric Co.
Rosemount and the Rosemount logotype are registered trademarks of Rosemount Inc.
All other marks are the property of their respective owners.*

Standard Terms and Conditions of Sale can be found at www.rosemount.com/terms_of_sale

**Emerson Process Management
Rosemount Flow**
7070 Winchester Circle
Boulder, Colorado USA 80301
Tel (USA) 1 800 522 6277
Tel (International) +1 303 527 5200
Fax +1 303 530 8549

Emerson Process Management
Blegistrasse 23
P.O. Box 1046
CH 6341 Baar
Switzerland
Tel +41 (0) 41 768 6111
Fax +41 (0) 41 768 6300

Emerson FZE
P.O. Box 17033
Jebel Ali Free Zone
Dubai UAE
Tel +971 4 811 8100
Fax +971 4 886 5465

Emerson Process Management Asia Pacific Pte Ltd
1 Pandan Crescent
Singapore 128461
Tel +65 6777 8211
Fax +65 6777 0947
Service Support Hotline : +65 6770 8711
Email : Enquiries@AP.EmersonProcess.com